

## UNIT I

### FLUID POWER PRINCIPLES AND FUNDAMENTALS (REVIEW)

**FLUID POWER:** It may be defined as the technology that deals with the generation, control and transmission of power using pressurized fluids

#### TYPES OF FLUID SYSTEMS:

**Fluid Transport systems:** The objective of the fluid transport systems is to transport fluids from one place to another place to achieve some useful purpose

**Fluid Power systems:** The Fluid power system is primarily designed to perform work. That is these systems use pressurized fluids to produce some useful mechanical movements to accomplish the desired work.

Method of transmitting power:

- ❖ Electrical power transmission
- ❖ Mechanical power transmission
- ❖ Fluid power transmission
  - Hydraulic power transmission
  - Pneumatic power transmission

#### ADVANTAGES OF FLUID POWER:

1. Easy and Accuracy to Control With the use of simple levers and push buttons, the fluid power system can facilitate easy starting, stopping, speeding up or slowing down and positioning forces that provide any desired power
2. Multiplication of small forces to achieve greater forces for performing work
3. It easily provides infinite and step less variable speed control which is difficult to obtain from other drives
4. Accuracy in controlling small or large forces with instant reversal is possible with hydraulic systems
5. Constant force is possible in fluid power system regardless of special motion requirements. Whether the work output moves a few millimeters or several meters per

minute.

6. As the medium of power transmission is fluid, it is not subjected to any breakage of parts as in mechanical transmission.
7. The parts of hydraulic system are lubricated with the hydraulic liquid itself.
8. Overloads can easily controlled by using relief valves than is possible with overload devices on the other systems. Air equipments reduces the danger of fire and explosion hazard in industries such as painting and mining.
9. Because of the simplicity and compactness the cost is relatively low for the power transmitted.
10. No need of lubrication

**DISADVANTAGES:**

1. Leakage of oil or compressed air
2. Busting of oil lines, air tanks
3. More noise in operation

**APPLICATIONS OF FLUID POWER:**

1. **Agriculture:** Tractors and farm equipments like ploughs, mowers, chemical sprayers, fertilizer spreaders, hay balers
2. **Automation:** Automated transfer machines
3. **Aviation:** Fluid power equipments like landing wheels on aeroplane and helicopter, aircraft trolleys, aircraft engine test beds.
4. **Building Industry:** For metering and mixing of concrete ingredients from hopper.
5. **Construction Equipment:** Earthmoving equipments like excavators, bucket loaders, dozers, crawlers, post hole diggers and road graders.
6. **Defense :** Missile-launch systems and Navigation controls
7. **Entertainment:** Amusement park entertainment rides like roller coasters
8. **Fabrication Industry:** Hand tools like pneumatic drills, grinders, bores, riveting machines, nut runners
9. **Food and Beverage:** All types of food processing equipment, wrapping, bottling
10. **Foundry:** Full and semi automatic molding machines, tilting of furnaces, die casting machines
11. **Glass Industry:** Vacuum suction cups for handling
12. **Material Handling:** Jacks, Hoists, Cranes, Forklift, Conveyor system

**HYDRAULIC SYSTEM:**

An electric motor drives the hydraulic pump so that the fluid is pumped from the tank at the required pressure. The fluid circulated into the system should be clean to reduce the wear of the pump and cylinder; hence a filter is used immediate to the storage tank. Since the pump delivers

constant volume of fluid for each revolution of the shaft the fluid pressure rises indefinitely until a pipe or pump itself fails. To avoid this some kind of pressure regulators is used to spill out the excess fluid back to the tank. Cylinder movement is controlled by a 3 position change over control valve. One side of the valve is connected to a pressurized fluid line and the fluid retrieval line and other side of the valve is connected to port A and port B of the cylinder. Since the hydraulic circuit is a closed one, the liquid transferred from the storage tank to one side of the piston, and the fluid at the other side of the piston is retrieved back to the tank.

**Raise:** To lift the weight, the pressurized fluid line has to be connected to port A and the retrieval line has to be connected to the port B, by moving the valve position to “raise”.

**Lower:** To bring down the weight, the pressurized fluid line has to be connected to port B and the retrieval fluid line has to be connected to port A, by moving the valve position to “lower”.

**Off:** The weight can be stopped at a particular position by moving the valve position to off. This disconnects the port A and port B from the pressurized line and the retrieval line which locks the fluid in the cylinder.

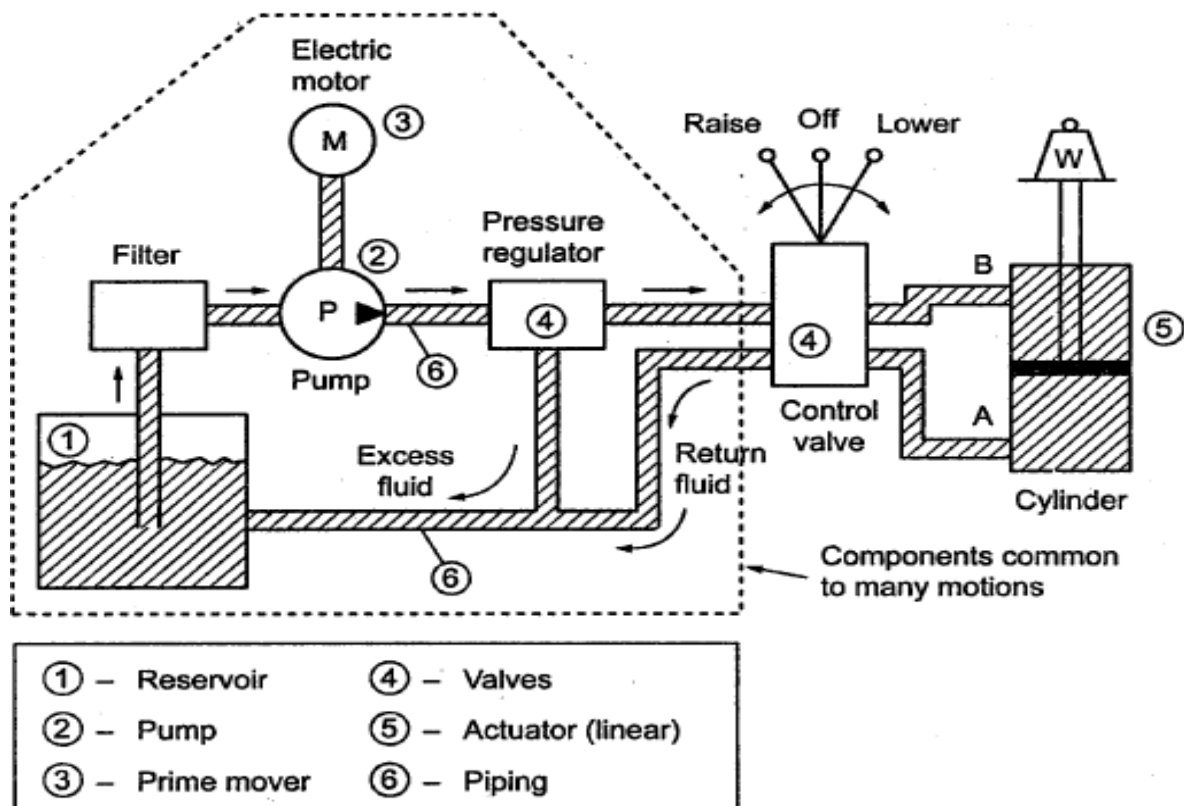

**General arrangement of a hydraulic system**

**PNEUMATIC POWER SYSTEM:**

Air is drawn from the atmosphere through the air filter and raised to the required pressure by an air compressor. Air contains significant amount of water vapour and also the air temperature is raised considerably by the compressor. So the air must be cooled before using it in the system, which results in condensation. The compressed air is stored in the reservoir which has water outlet at the bottom of the reservoir and a pressure switch to control the pressure of the compressed air. Pressure switch stops the motor when the required pressure is attained and starts the motor when

the pressure falls down the mark. The cylinder movement is controlled by the pneumatic valve. One side of the pneumatic valve is connected to the compressed air line and silencers for the exhaust air and the other side of the valve is connected to port A and port B of the cylinder.

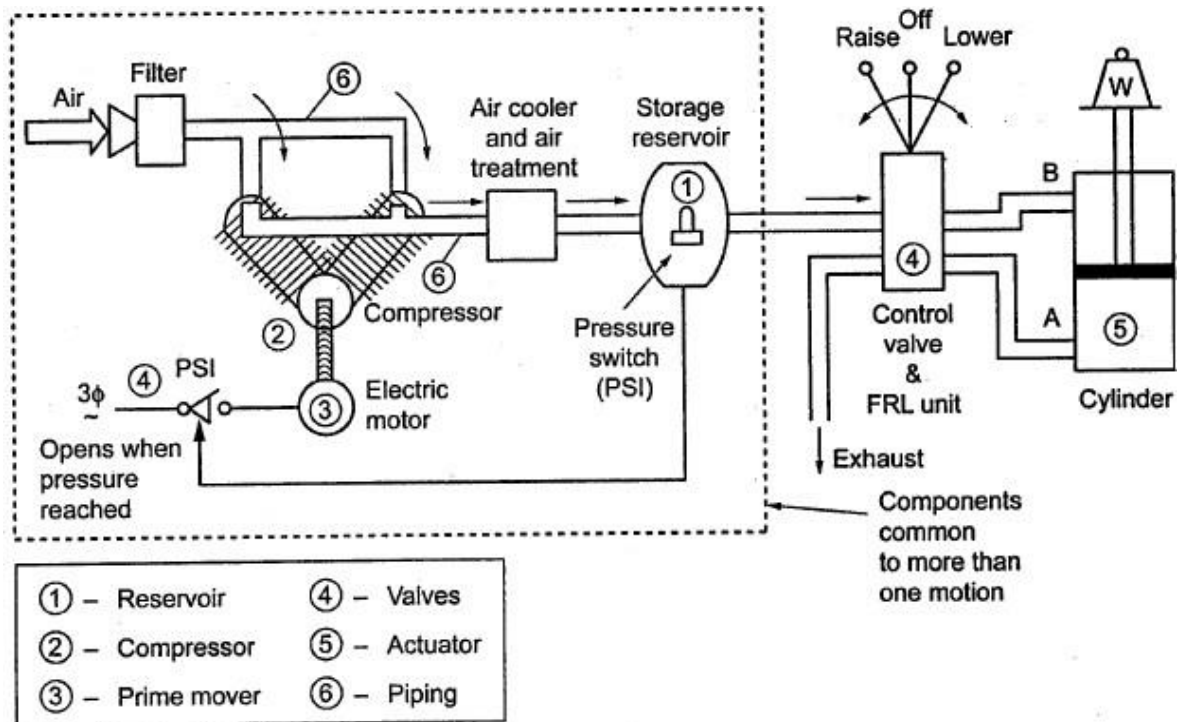

**Raise:** To lift the weight, the compressed air line has to be connected to port A and the port B is connected to the exhaust air line by moving the valve position to raise.

**Lower:** To bring down the weight, the compressed air line is connected to port B and the port A is connected to exhaust air line by moving the valve position to lower.

**Off:** The weight can be stopped at a particular position by moving the valve position to off. This disconnects the port A and port B from the pressurized line and the retrieval line which locks the air in the cylinder.

**COMPARISON BETWEEN HYDRAULIC, PNEUMATIC AND ELECTRO MECHANICAL POWER SYSTEM**

Hydraulic System	Pneumatic System	Electro-Mechanical System
Pressurized Liquid is used	Compressed Air is used	Energy is transmitted through mechanical components
Energy stored in Accumulator	Energy stored in Tank	Energy stored in Batteries
Hydraulic Valves are used	Pneumatic Valves are used	Variable Frequency drives

Transmission through Hydraulic cylinders, Actuators	Transmission through Pneumatic cylinders ,Actuators	Transmission through Mechanical components like Gears, Cams
--	---	---



Hydraulic System	Pneumatic System	Electro-Mechanical System
Flow rate is 2 to 6 m/s	Flow rate is 20-40 m/s	Excellent with minimum loss
More Precision	Less Precision	More Precision
Large force can be generated	Limited force can be achieved	Large force can be realized but poor in efficiency
Medium Cost	High cost	Low Cost
Dangerous and fire hazardous because of leakage	Noisy	Easy to work

**FUNCTIONS OF FLUIDS IN A FLUID POWER SYSTEM:**

1. Transfer fluid power efficiently
2. Lubricate the moving parts
3. Absorb, Carry and Transfer heat generated within the system
4. Be compatible with hydraulic components
5. Remain stable against physical and chemical changes

**VARIOUS HYDRAULIC FLUIDS:**

- ❖ **Water:** The least expensive hydraulic fluid is water. Water is treated with chemicals before being used in a fluid power system. This treatment removes undesirable contaminants. **Advantages:** Inexpensive, Readily available, Fire resistance  
**Disadvantage:** No lubricity, Corrosive, Temperature limitations
- ❖ **Petroleum Oils:** These are the most common among the hydraulic fluids which are used in a wide range of hydraulic applications. The characteristic of petroleum based hydraulic oils are controlled by the type of crude oil used. Naphthenic oils have low viscosity index so it is unsuitable where the oil temperatures vary too widely. The aromatics have a higher

presence of benzene and they are more compatible with moderate temperature variation. Paraffinic oils have a high viscosity index and they are more suitable for the system where the temperature varies greatly.

**Advantages:** Excellent lubricity, Reasonable cost, Non-corrosive

**Disadvantage:** Tendency to oxidize rapidly, Not fire resistance

❖ **Water Glycols:** These are solutions contains 35 to 55% water, glycol and water soluble thickener to improve viscosity. Additives are also added to improve anticorrosion, anti wear and lubricity properties.

**Advantages:** Better fire resistance, Less expensive, Compatible with most pipe compounds and seals

**Disadvantage:** Low viscosity, Poor corrosion resistance, not suitable for high loads

❖ **Water Oil Emulsions:** These are water-oil mixtures. They are of two types oil-in-water emulsions or water-in-oil emulsions. The oil-in-water emulsion has water as the continuous base and the oil is present in lesser amounts as the dispersed media. In the water-in-oil emulsion, the oil is in continuous phase and water is the dispersed media.

**Advantages:** High viscosity index, Oxidation stability, Film strength

**Disadvantage:** Depletion of water due to evaporation decreases fire resistance, Demulsification may be problem with water-in-oil emulsions.

❖ **Phosphate Ester:** It results from the incorporation of phosphorus into organic molecules. They have high thermal stability. They serve as an excellent detergent and prevent building up of sludge.

**Advantages:** Excellent fire resistance, Good lubricity, Non corrosive

**Disadvantage:** Not compatible with many plastics and elastomers, Expensive

### PROPERTIES OF FLUIDS:

**1. Viscosity:** It is a measure of the fluid's internal resistance offered to flow. Viscosity is the most important factor from the stand point of flow. If the viscosity of the hydraulic oil is higher than recommended, the system will be affected in the following manner.

1. The viscous oil may not be able to pass through the pipes.
2. The working temperature will increase because there will be internal friction.
3. The consumption of power will increase

If the viscosity of the oil is lesser than recommended then,

1. The internal and external leakage will increase
2. It cannot lubricate properly and will lead to rapid wear of the moving parts.

**2. Viscosity Index:** This value shows how temperature affects the viscosity of oil. The viscosity of the oil decreases with increase in temperature and vice versa. The rate of change of viscosity with temperature is indicated on an arbitrary scale called viscosity index (VI). The lower the viscosity index, the greater the variation in viscosity with changes in temperature and vice versa.

**3. Oxidation Stability:** The most important property of an hydraulic oil is its oxidation stability. Oxidation is caused by a chemical reaction between the oxygen of the dissolved air and the oil. The oxidation of the oil creates impurities like sludge, insoluble gum and soluble acidic products. The soluble acidic products cause corrosion and insoluble products make the operation sluggish.

**4. Demulsibility:** The ability of a hydraulic fluid to separate rapidly from moisture and successfully resist emulsification is known as Demulsibility. If oil emulsifies with water the emulsion will promote the destruction of lubricating value and sealant properties. Highly refined oils are basically water resistance by nature.

**5. Lubricity:** Wear results in increase clearance which leads to all sorts of operational difficulties including fall of efficiency. At the time of selecting a hydraulic oil care must be taken to select one which will be able to lubricate the moving parts efficiently.

**6. Rust Prevention:** The moisture entering into the hydraulic system with air causes the parts made ferrous materials to rust. This rust if passed through the precision made pumps and valves may scratch the nicely polished surfaces. So additives named inhibitors are added to the oil to keep the moisture away from the surface.

**7. Pour Point:** The temperature at which oil will clot is referred to as the pour point i.e. the lowest temperature at which the oil is able to flow easily. It is of great importance in cold countries where the system is exposed to very low temperature.

**8. Flash Point and Fire Point:** Flash point is the temperature at which a liquid gives off vapour in sufficient quantity to ignite momentarily or flash when a flame is applied. The minimum temperature at which the hydraulic fluid will catch fire and continue burning is called fire point.

**9. Neutralization Number:** The neutralization number is a measure of the acidity or alkalinity of a hydraulic fluid. This is referred to as the PH value of the fluid. High acidity causes the oxidation rate in an oil to increase rapidly.

**10. Density:** It is that quantity of matter contained in unit volume of the substance.

**11. Compressibility:** All fluids are compressible to some extent. Compressibility of a liquid causes the liquid to act much like a stiff spring. The coefficient of compressibility is the fractional change in a unit volume of liquid per unit change of pressure

**REQUIRED QUALITIES OF GOOD HYDRAULIC OIL:**

1. Stable viscosity characteristics
2. Good lubricity
3. Compatibility with system materials
4. Stable physical and chemical properties
5. Good heat dissipation capability
6. High bulk modulus and degree of incompressibility
7. Good flammability
8. Low volatility
9. Good demulsibility
10. Better fire resistance
11. Non toxicity and good oxidation stability
12. Better rust and corrosion prevent qualities
13. Ready availability and inexpensive

**FLUID FLOW:**

**Laminar Flow:** It is one in which paths taken by the individual particles do not cross one another and moves along well defined paths. The laminar flow is characterized by the fluid flowing in smooth layers of lamina. This type of flow is also known as streamline or viscous flow because the particles of fluid moving in an orderly manner and retaining the same relative positions in successive cross sections.

**Examples:**

1. Flow of oil in measuring instruments
2. Flow of blood in veins and arteries

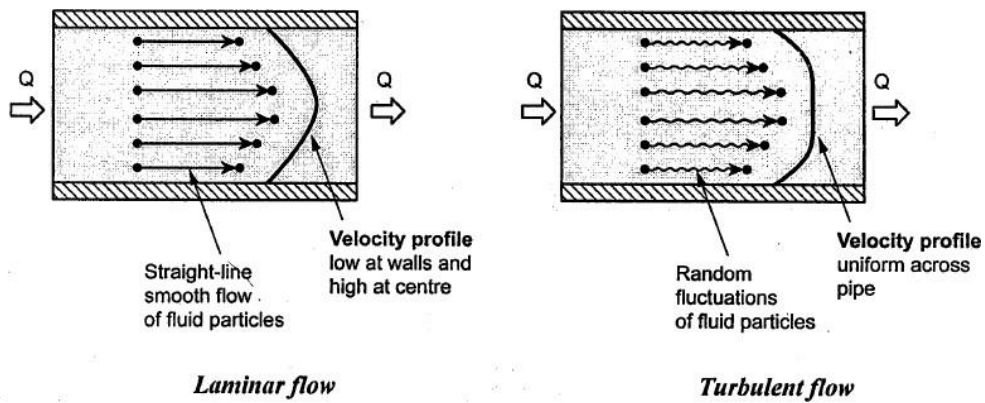

**Turbulent Flow:** It is that flow in which fluid particles move in a zigzag way. It is characterized by continuous small fluctuations in the magnitude and direction of the velocity of the fluid particles. It causes more resistance to flow, greater energy loss and increase in fluid temperature due to greater energy loss.

**Examples:** High velocity flow in a pipe of large size



**REYNOLDS NUMBER:**

Osborne Reynolds in 1883 conducted experiments to ascertain the conditions under which a flow through pipe is laminar or turbulent. He applied the dimensional analysis on variables and introduced a dimensionless number called Reynolds number Re. It is given by the following equation to determine whether the flow is laminar or turbulent.

$$Re = \frac{\rho V D}{\mu}$$

□ □

ρ = Density of fluid

(kg/m<sup>3</sup>) V = Velocity of Flow (m/sec)

D = Inside diameter of pipe (m)

ν = Kinematic viscosity of fluid

(m<sup>2</sup>/sec) μ = absolute viscosity of fluid (Ns/m<sup>2</sup>)

Experiments showed that the flow is laminar when Reynolds number (Re) is less than 2000 and turbulent for Re greater than 4000. And for 2000 < Re < 4000 then the flow is in transition from laminar to turbulent. It is always desirable to maintain laminar flow in hydraulic system because the chaotic turbulent flow causes more energy loss.

**DARCY – WEISBACH EQUATION:**

The energy loss due to friction in a hydraulic system results in a loss of potential energy. This potential energy loss leads to a pressure drop or head loss in the system. Pressure or head loss due to friction in pipes carrying fluids are derived using the Darcy-Weisbach Equation.

$$HL = f \left( \frac{L}{D} \right) \left( \frac{V^2}{g} \right)$$

HL – Head Loss

V – Velocity of Flow

f - Friction Factor                      g – Acceleration due to  
gravity  
L - Length of pipe  
D – Inner Diameter

During laminar flow the friction is relatively independent of the surface conditions of the inside diameter of the pipe.

The friction factor 'f' for laminar flow can be found by the equation

$$f = \frac{64}{\text{Re}} \text{ when } \text{Re} < 2000$$

Re

But in turbulent flow friction factor depends on both the Reynolds number and roughness of the pipe. An American engineer L.F.Moody documented the experimental and theoretical investigation on the laws of friction in pipe flow in form of a diagram. He showed the variation of friction factor with the

□ governing parameters namely the Reynolds number and relative roughness  $\frac{\epsilon}{D}$  of the pipe. This

diagram is known as Moody diagram which is employed for predicting the values of 'f' in turbulent flow.

**LOSSES IN VALVES AND FITTINGS:**

Pressure drops are also due to valves, expansions, contractions, bends, elbows, tees and pipe fittings. The losses in valves and fittings in hydraulic systems are frequently computed in terms of equivalent length of hydraulic tube. Equivalent lengths can then be substituted in Darcy-Weisbach equation to solve for total pressure loss in the system. The formula for computing equivalent length is

$KD$

Equivalent length  $L_e = \frac{KD}{f}$       k= Factor for valve and fittings

$f$

Valve and Fitting	K Factor
<b>Globe Valve</b>	
Full open	10
Half open	12.5
<b>Gate Valve</b>	
Full open	0.19
Half open	4.5
<b>Check Valve</b>	
Poppet	3.0
Type Ball type	4.0
Return Bend	2.2
Standard Tee	1.8
Standard Elbow	0.9
45° Elbow	0.42

**PASCAL'S LAW :**

This law states that the pressure generated at any point in a confined fluid acts equally in all

Consider two oil containers both in cylindrical form and connected together contain some oil, as shown Both the cylinders have a piston having different diameters says  $D_1$  and  $D_2$  respectively, where  $D_1$  is smaller than  $D_2$ .

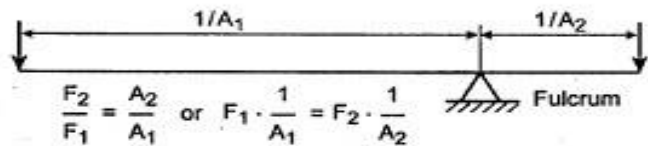
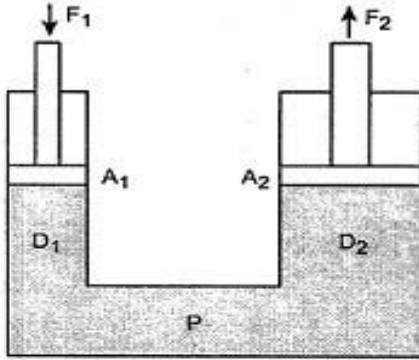

*Principle of Bramah's press*

*A hydraulic lever*

If a force  $F_1$  is applied to the small-diameter piston, then this will produce an oil pressure  $P_1$  at the bottom of the piston 1. Now this pressure is transmitted through the oil to the large-diameter piston 2. Because the piston 2 has a larger area ( $A_2$ ), the pressure at the bottom of the piston 2 will be  $P_2$ . Now this pressure  $P_2$  will push up the piston 2 to create an output force  $F_2$ .

We know that according to Pascal's law,  $P_1 = P_2$

or 
$$\frac{F_1}{A_1} = \frac{F_2}{A_2}$$

or 
$$\boxed{\frac{F_2}{F_1} = \frac{A_2}{A_1}}$$

where  $A_1 =$  Area of the smaller piston  $= \frac{\pi}{4} D_1^2$ , and

$A_2 =$  Area of the larger piston  $= \frac{\pi}{4} D_2^2$ .

directions.

**CONTINUITY EQUATION:** It states that if no fluid is added or removed from the pipe in any length then the mass passing across different sections shall be same.

$A_1 V_1 = A_2 V_2$

**BERNOULLI'S EQUATION:** It states that in a ideal incompressible fluid when the flow is steady and continuous the sum of potential energy, kinetic energy and pressure energy is constant across all cross sections of the pipe.

$V^2 + P$        $V^2 + P$

$$Z_1 + \frac{1}{2g} + \frac{1}{w} = Z_2 + \frac{2}{2g} + \frac{2}{w}$$

$$2g \quad w \quad 2g \quad w$$

**UNIT II****HYDRAULIC SYSTEM AND COMPONENTS****Introduction:**

A pump which is the heart of a hydraulic system converts mechanical energy into hydraulic energy. The mechanical energy is delivered to the pump via prime mover such as electric motor. Due to the mechanical action the pump creates a partial vacuum at its inlet. This permits atmospheric pressure to force the fluid through the inlet line and into the pump. The pump then pushes the fluid into the hydraulic system.

**Pump Classifications:**

1. **Non Positive Displacement Pumps:** The most common types of dynamic pumps are the centrifugal and axial pumps. Although these pumps provide smooth continuous flow, their flow output is reduced as circuit resistance is increased and thus are rarely used in fluid power systems. In dynamic pumps there is a great deal of clearance between the rotating impeller and the stationary housing. Thus as the resistance of the external system starts to increase, some of the fluid slips back into the clearance spaces, causing a reduction in the discharge flow rate. This slippage is due to the fact that the fluid follows the path of least resistance. When the resistance of the external system becomes infinitely large the pump will produce no flow. These pumps are typically used for low pressure, high volume flow applications. Also since there is a great deal of clearance between the rotating and stationary elements, dynamic pumps are not self priming unlike positive displacement pump.
2. **Positive Displacement Pump:** This type of pump ejects a fixed quantity of fluid per revolution of the pump shaft. As a result, pump output flow, neglecting changes in the small internal leakage is constant and not dependent on system pressure. This makes them particularly well suited for fluid power systems. However positive displacement pumps must be protected against overpressure if the resistance to flow becomes very large. This can happen if a valve is completely closed and there is no physical place for the fluid to go. The reason for this is that a positive displacement pump continues to eject fluid causing an extremely rapid buildup in pressure as the fluid compressed. A pressure relief valve is used to protect the pump against overpressure by diverting pump flow back to the hydraulic tank where the fluid is stored for system use.

**Classification of Positive Displacement Pump:**

1. Gear Pumps
  - a. External Gear Pump
  - b. Internal Gear Pump
  - c. Lobe Pump
  - d. Screw Pump

2. Vane Pumps
  - a. Unbalanced Vane Pumps
  - b. Balanced Vane Pumps
  - c. Pressure Compensated Vane Pump
3. Piston pumps
  - a. Axial Piston Pump
  - b. Radial Piston Pump

**GEAR PUMPS:**

**External Gear Pump:**

The given figure shows the operation of an external gear pump, which develops flow by carrying fluid between the teeth of two meshing gears. One of the gears is connected to a drive shaft connected to the prime mover. The second gear is driven as it meshes with the driver gear. Oil chambers are formed between the gear teeth, the pump housing and the side wear plates. The suction side is where teeth come out of mesh and it is here that the volume expands bringing about a reduction in pressure to below atmospheric pressure. Fluid is pushed into this void by atmospheric pressure because the oil supply tank is vented to the atmosphere. The discharge side is where teeth go into mesh and it is here that the volume decreases between mating teeth. Since the pump has a positive internal seal against leakage the oil is positively ejected into the outlet port. The displacement of the gear pump is determined by volume of fluid between each pair of teeth, Number of teeth and speed of rotation.

$$Q_T = V_D \times N$$

□

$$V_D = \frac{(D_o^2 - D_i^2) L}{4}$$

Q<sub>T</sub> – Theoretical Pump Flow Rate    L – Width Of  
 Gear    V<sub>D</sub> – Displacement Volume of Pump    N – Speed  
 of Pump    D<sub>o</sub>, D<sub>i</sub> – Outside and Inside Diameter of Gear  
 Teeth



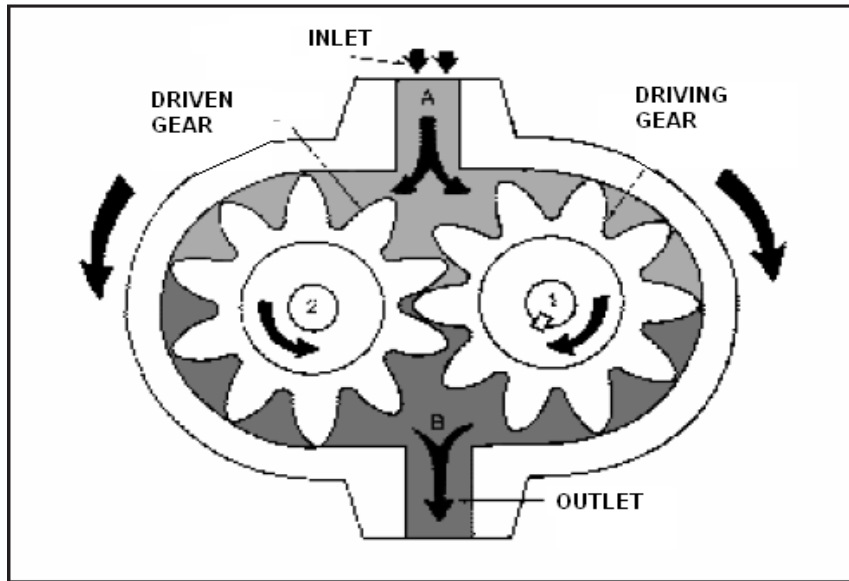

There must be a small clearance between the teeth tip and pump housing. As a result some of the oil at the discharge port can leak directly back toward the suction port. This means that the actual flow rate  $Q_A$  is less than the theoretical flow rate  $Q_T$  which is based on volumetric displacement and pump speed. This internal leakage called pump slippage is identified by the term volumetric efficiency.

$$\eta_v = \frac{Q_A}{Q_T}$$

### Advantages

- High speed
- High pressure
- No overhung bearing loads
- Relatively quiet operation
- Design accommodates wide variety of materials

### Disadvantages

- Four bushings in liquid area
- No solids allowed
- Fixed End Clearances

### Applications

- Various fuel oils and lube oils
- Chemical additive and polymer metering
- Chemical mixing and blending (double pump)
- Industrial and mobile hydraulic applications splitters, lifts
- Acids and caustic (stainless steel or composite construction) Low volume transfer or application

### Internal Gear Pump:

The figure shows the operation of the internal gear pump. This design consists of an internal gear, a regular spur gear, a crescent shaped seal and an external housing. As power is applied to either gear the motion of the gears

draws fluid from the reservoir and forces it around both sides of the crescent seal which acts as a seal between the suction and discharge ports. When the teeth mesh on the side opposite to the crescent seal the fluid is forced to enter the discharge port of the pump.

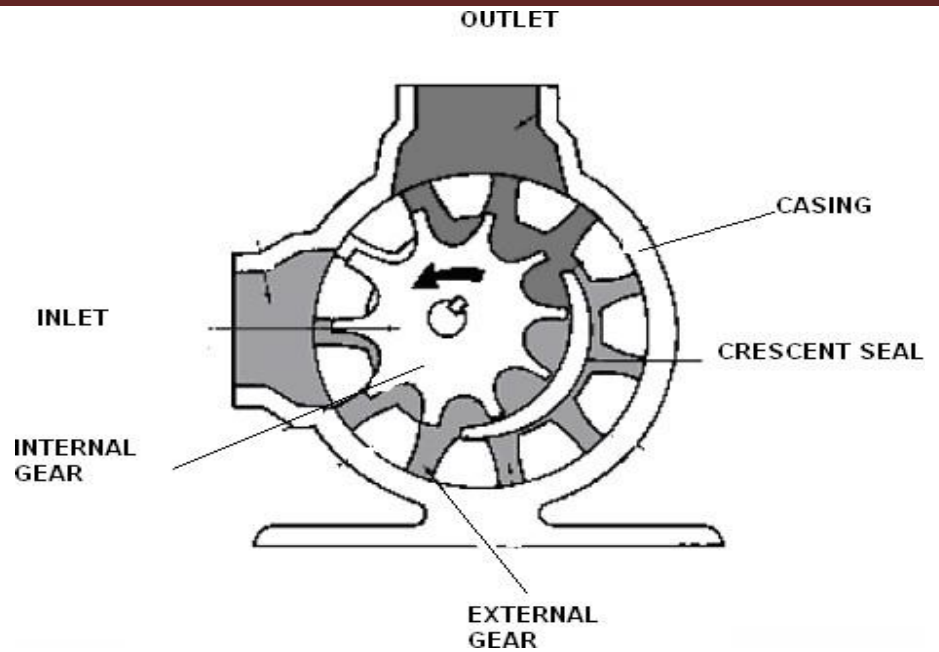

### Advantages

- Only two moving parts
- Non-pulsating discharge
- Excellent for high-viscosity liquids
- Constant and even discharge regardless of pressure conditions
- Operates well in either direction
- Single adjustable end clearance

### Disadvantages

- Usually requires moderate speeds
- Medium pressure limitations
- One bearing runs in the product pumped
- Overhung load on shaft bearing

### Applications

- All varieties of fuel oil and lube oil
- Resins and Polymers
- Alcohols and solvents
- Food products such as corn syrup, chocolate, and peanut butter
- Paint, inks, and pigments

### Lobe Pump:

In this pump, the gears are replaced by the lobes. This pump operates in a similar fashion as that of external pump. But unlike the external gear pump, these both lobes are driven independently and they do not have actual contact with each other.

Lobe contact is prevented by external timing gears located in the gearbox. Pump shaft support bearings are located in the gearbox, and since the bearings are out of the pumped liquid, pressure is limited by bearing location and shaft deflection. As the lobes come out of mesh, they create expanding volume on the inlet side of the pump. Liquid flows into the cavity and is trapped by the lobes as they rotate. Liquid travels around the interior of the casing in the pockets between the lobes and the casing it does not pass between the lobes. Finally, the meshing of the lobes forces liquid through the outlet port under pressure. So, they are quieter than other types of gear pumps. Since the lobe pump has smaller number of mating

elements, the lobe pump output will have a somewhat greater amount of pulsating, although its volumetric displacement is generally greater than that for other types of gear pumps. Lobe pumps are frequently used in food applications because they handle solids without damaging the product.

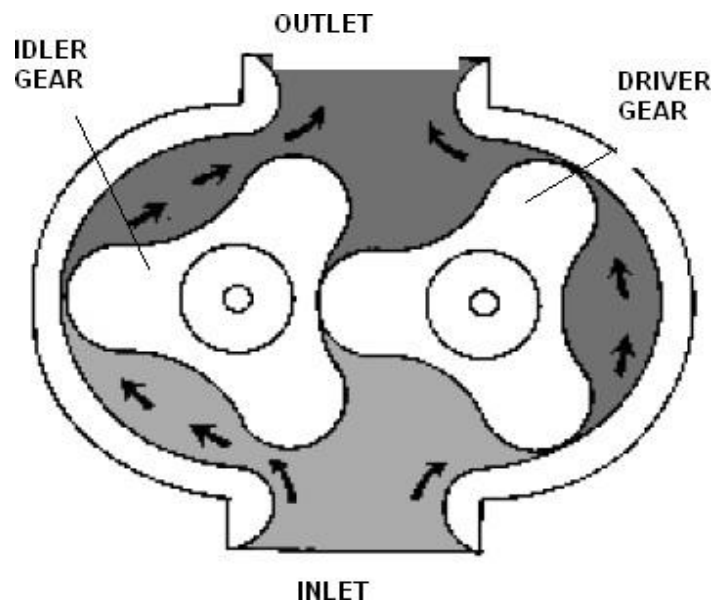

### Advantages

- Pass medium solids
- No metal-to-metal contact
- Long term dry run (with lubrication to seals)

### Disadvantages

- Requires timing gears
- Requires two seals
- Reduced lift with thin liquids

### Applications

- Paper coatings
- Soaps and surfactants
- Paints, dyes, Rubber and adhesives
- Pharmaceuticals

**Gerotor Pump:** It is a positive displacement pumping unit. The name gerotor is derived from "Generated Rotor". A gerotor unit consists of an inner and outer rotor. The inner rotor has N teeth, and the outer rotor has N+1 teeth. The inner rotor is located off-center and both rotors rotate. During part of the assembly's rotation cycle, the area between the inner and outer rotor increases, creating a vacuum. This vacuum creates suction, and hence, this part of the cycle is where the intake is located. Then, the area between the rotors decreases, causing compression. During this compression period, fluids can be pumped, or compressed (if they are gaseous fluids).

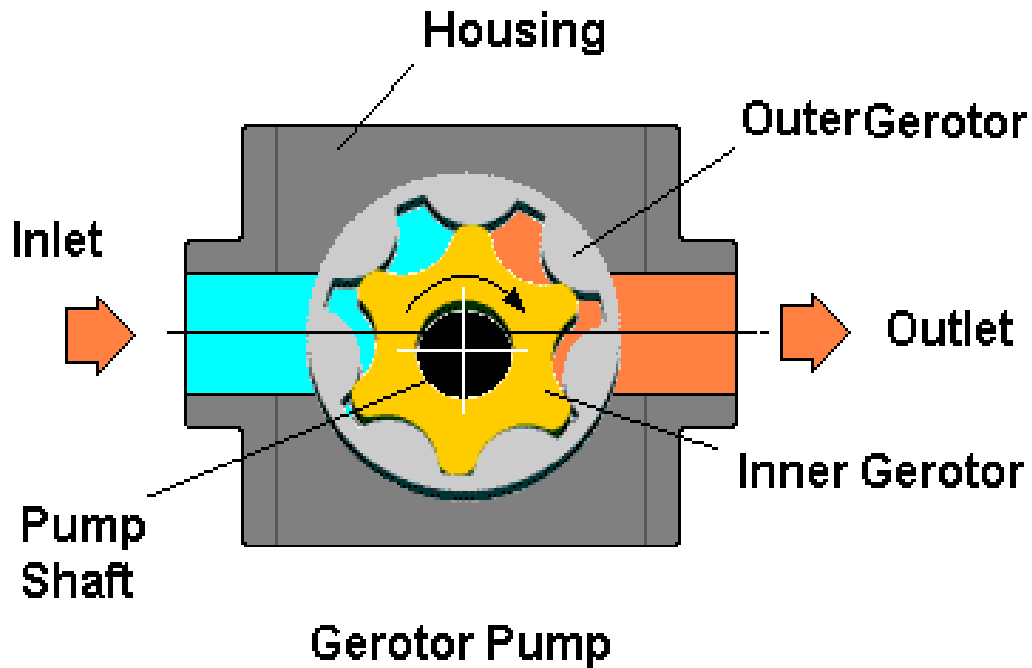

Gerotor pumps are generally designed using a trochoidal inner rotor and an outer rotor formed by a circle with intersecting circular arcs. A gerotor can also function as a motor. High pressure gas enters the intake area and pushes against the inner and outer rotors, causing both to rotate as the area between the inner and outer rotor increases. During the compression period, the exhaust is pumped out.

### Advantages

- High Speed
- Only two moving parts
- Constant and even discharge regardless of pressure conditions
- Operates well in either direction
- Quiet operation

### Disadvantages

- Medium pressure limitations
- Fixed clearances
- No solids allowed
- One bearing runs in the product pumped
- Overhung load on shaft bearing

### Applications

- Light fuel oils
- Lube oil
- Cooking oils
- Hydraulic fluid

### Screw Pump:

It is an axial flow positive displacement unit. Three precision ground screws, meshing within a close fitting housing, deliver non pulsating flow quietly and efficiently. The two symmetrically opposed idler rotors act as rotating seals, confining the fluid in a succession of closures or stages. The idler rotor are in rolling contact with the central power rotor and are free to float in their respective housing bores on a hydrodynamic oil film. There are no radial bending loads. Axial hydraulic forces on the rotor set are balanced, eliminating any need for thrust bearings. The liquid is introduced at the two ends and discharged at the centre. The pumping action comes from the sealed chamber. The sealed chamber formed by the contact of the two gears at the intersection of their addenda and by the small clearance between the screws and the pump housing. This working is similar to a nut moving along a thread rod when the rod rotated. In these pumps, it should be noted that the liquid does not rotate but moves linearly. Thus the liquid moves forward along the axis with the rotation of the screw and is discharged to the outlet port.



**Advantages:**

1. Give uniform pressure with negligible pulsations.
2. Very quiet, because of rolling action of the screw spindles.
3. Can handle liquids containing vapour and gases

**Disadvantages:**

1. It is difficult to manufacture the screw profile to maintain close tolerance.
2. Overall volumetric and mechanical efficiency is relatively low.

**Types of Vane Pumps:**

1. Unbalanced Vane Pumps
  - a. Fixed displacement unbalanced pumps
  - b. Variable displacement unbalanced pumps
2. Balanced Vane Pumps

**Unbalanced Vane Pump:**

The pump consists of a rotor which contains radial slots splined to the drive shaft. The rotor rotates inside a cam ring. Each slot contains a vane which is free to slide in or out of the slots in the pump rotor. The vane is designed to mate with the surface of the cam ring as the rotor turns. The cam ring axis is offset to the drive shaft axis. As the rotor rotates, the centrifugal force pushes the vanes out against the surface of the cam ring. The vanes divide the space between the rotor and the cam ring into a series of small chambers. During the first half of rotor rotation, the volume of these chambers increase, thereby causing a reduction of pressure. This is the suction process which causes the fluid to flow through the inlet port and fill the void.

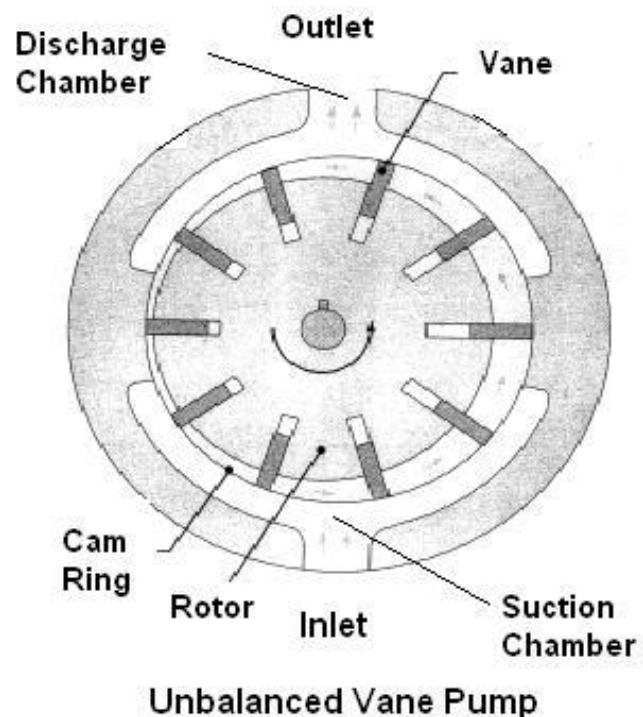

As the rotor rotates through the second half, the cam ring pushes the vane back into their slots

and the trapped volume is reduced. This positively ejects the trapped fluid through the outlet port. In this pump, all the pumping action takes place in the chambers located on the one side of the rotor and shaft. So the pump is of an unbalanced design.

**Fixed Displacement Unbalanced Vane Pumps:** In this type rotor housing eccentricity is constant. Hence the displacement volume is fixed. A constant volume of fluid is discharged during each revolution of the rotor.

**Variable Displacement Unbalanced Vane Pump:** Variable displacement can be provided if the housing can be moved with respect to the rotor. This movement changes the eccentricity and hence the displacement. Usually a hand wheel or pressure compensator can be used to move the cam ring to change the eccentricity.

**Balanced vane pump:**

In balanced vane pump, the rotor rotates inside a cam ring of elliptical shape. It has two inlet and outlet ports which are diametrically opposite each other. Movement of the vanes in and out causes the chamber between

them to increase and decrease.

When these chambers are increasing in size, the fluid is being sucked into the pump through the inlet ports. The two inlet ports are connected to a common inlet passage. When the chambers are decreasing in size,

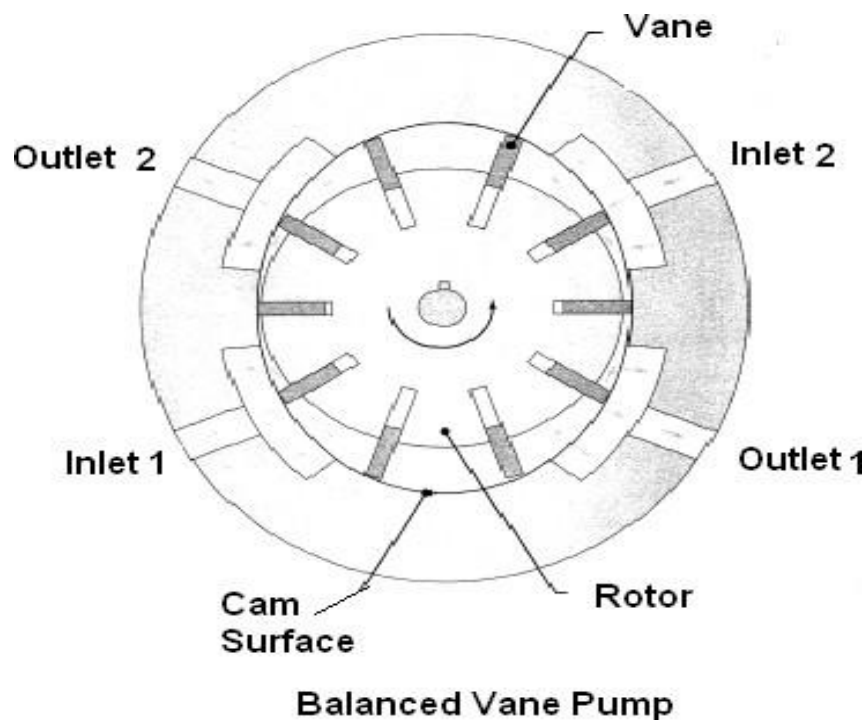

the fluid starts being delivered into the system through the outlet ports which are connected to a common outlet passage. Because the pressure ports are opposite to each other, a complete hydraulic balance can be achieved. One disadvantage of balanced vane pump is that it cannot be designed as a variable displacement pump.

**Advantages:**

1. Volumetric and overall efficiencies are high.
2. only small changes in capacity occur with variations in viscosity and discharge pressure
3. Their vanes are self compensating for wear and also vanes can be easily replaced.
4. They are self priming, robust and give constant delivery for a set rotor speed.

**Disadvantages:**

1. They cannot handle abrasive liquids
2. They require seals and foreign bodies can damage the pump
3. They cannot be operated against a closed discharge without damage to the pump. Hence relief valves are required

**Pressure Compensated Variable Delivery Pump:**

In this system pressure acts directly via a hydraulic piston on the right side. This forces the cam ring against a spring loaded piston on the left side. If the discharge pressure is large enough, it overcomes the compensator spring force and shifts the cam ring to the left. This reduces the eccentricity and decreases the flow. If the pressure continues to increase, there is no eccentricity and pump flow becomes zero.

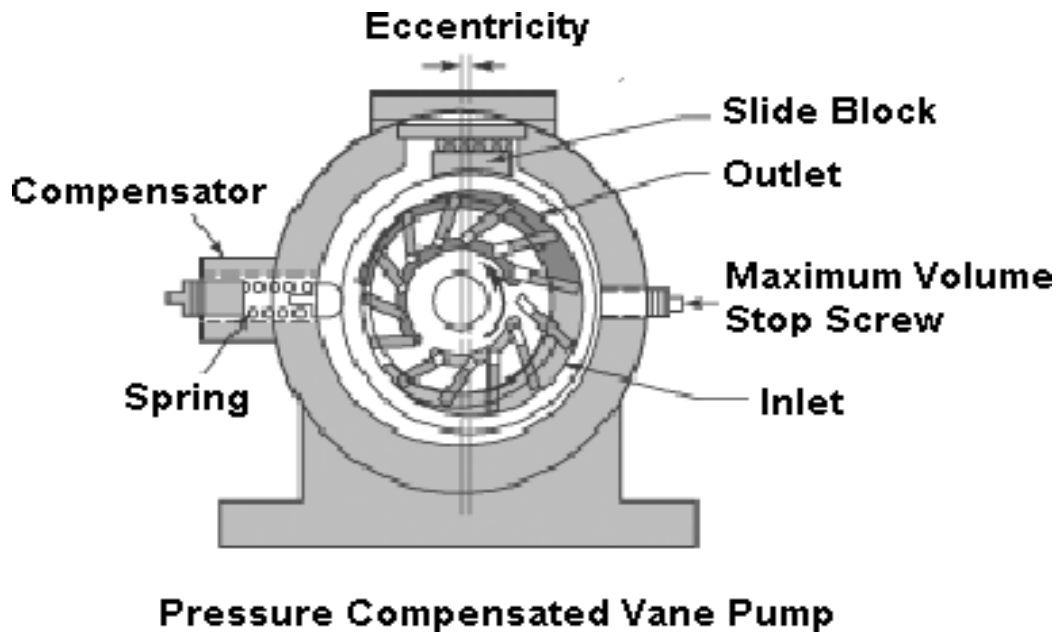

### **Piston Pumps:**

In piston pumps, the pumping action is affected by a piston that moves in a reciprocating cycle through a cylinder. The basic operations of piston pumps are very similar to that of the reciprocating engines. These pumps are classified as

1. Axial Piston Pumps
  - a. Swash plate axial piston pump
  - b. Bent axis Axial piston pump
2. Radial Piston Pumps

In axial piston pumps, a number of pistons and cylinders are located in a parallel position with respect to the drive shaft, while in the radial type they are arranged radially around the rotor hub.

### **Axial Piston Pump:**

In this type rotary shaft motion is converted to axial reciprocating motion which drives the piston. Most axial piston pumps are multi piston designs and utilize check valves or port plates to direct liquid flow from inlet to discharge. Output can be controlled by manual, mechanical or pressure compensated controls.

**Swash Plate (In line) axial Piston Pump:**

In this pump rotary drive motion is converted to reciprocating, axial piston motion by means of the swash plate, mounted on the drive shaft. Thus the rotation of the swash plate produces in and out motion of the piston in their cylinders and hence the fluid is discharged.

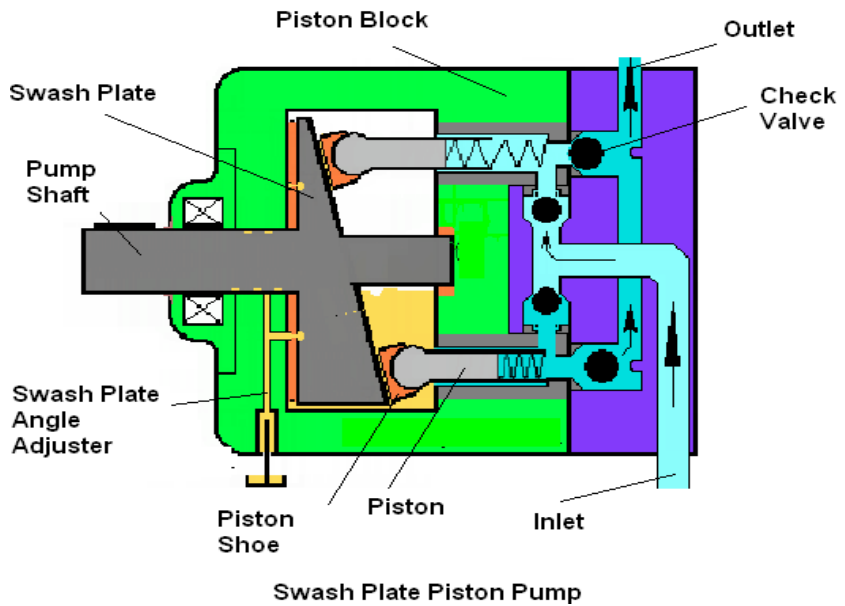

This type of pumps can also be designed to have variable

displacement capability. This can be achieved by altering the angle of the swash plate. Because in the swash plate axial pump, the angle of tilt of the swash plate determines the piston stroke and hence the pump displacement. The increase in the swash plate angle will increase the piston stroke and hence the fluid displacement. When the swash plate is vertical, then the displacement is zero. Even one can reverse the flow direction by changing the angle of swash plate. However, the maximum swash plate angle is generally limited to  $17.5^\circ$ , due to various design considerations.

**Bent Axis Axial Piston Pump:**

This type of pump contains a cylinder block rotating with the drive shaft. As shown the centerline of the cylinder block is bent at an offset angle relative to the centerline of the drive shaft. The cylinder has a number of pistons and cylinders arranged along a circle. The ball and socket joints connect the piston rods with the drive shaft flange. When the

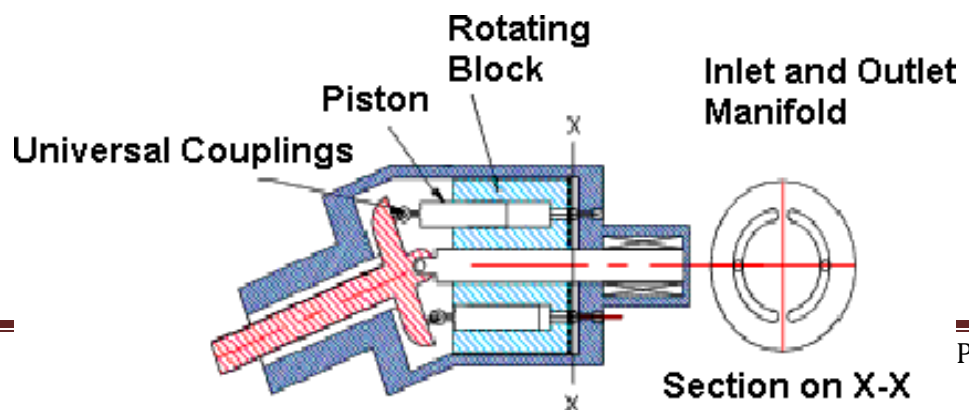

distance between the  
drive shaft flange  
and cylinder  
block  
k changes, the piston  
move in and out  
of



the cylinder. In order to provide alignment and positive drive, a universal link is used to connect the block to the drive shaft. When the piston carrying body turns, the exit passage in the cylinder bores move along the control slots of a firmly positioned control plate and are thus connected alternatively to suction or discharge pipelines.

In the fixed displacement pumps, the pumps are mounted in a fixed casing so that swing angle cannot be adjusted. So the fixed displacement of the piston and hence the constant discharge of fluid are achieved. In variable displacement pumps, the swing angle can be varied. Because the volumetric displacement of the pump varies with the offset angle. When the offset angle is zero, then the displacement will be zero. However, the angle will vary from  $0^\circ$  to  $30^\circ$ .

### Radial Piston Pump:

The radial piston pump has a number of radial pistons in a cylinder block which revolves around a stationary pintle or valve. The pistons remain in contact with the reaction ring due to centrifugal force and back pressure on the pistons. A drive shaft is attached to the end of cylinder block and provides the power needed to the pump. The reaction ring is moved eccentrically with respect to the pintle axis.

If the cylinder block is rotated in a clockwise direction, the pistons on one side travel outward and sucks the fluid when it passes the suction port of the pintle. When the piston passes the maximum point eccentricity, it is forced inward by the reaction ring. This force the fluid to enter into the discharge port. The displacement can be varied by moving the reaction ring to change the piston stroke.

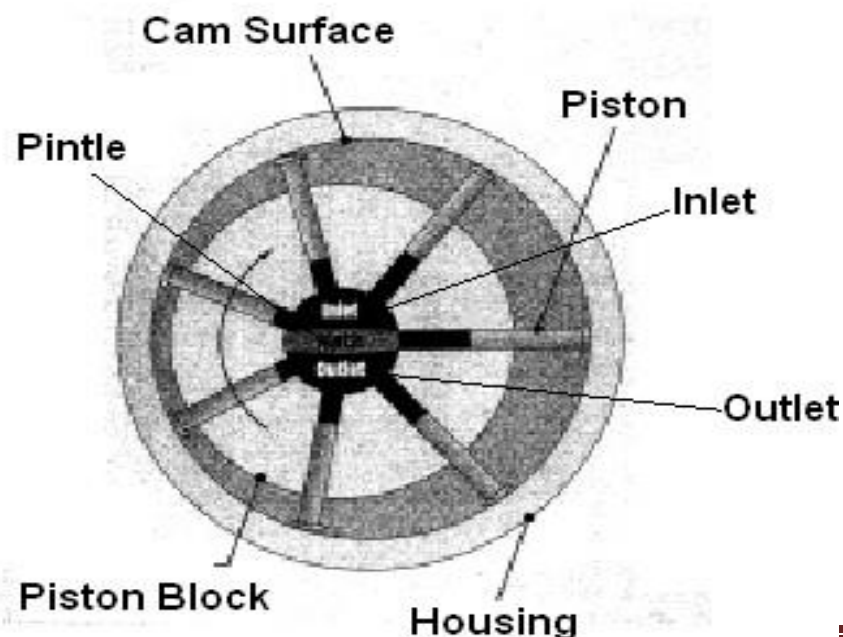

Radial Piston Pump

**Important Formulas:**

<p><b>1. Theoretical Discharge for Gear Pump:</b></p> $Q_T = \frac{(D_o^2 - D_i^2) b N}{4}$	<p><math>D_o</math> – Outer Diameter of Gear  <math>D_i</math> – Inner Diameter of Gear  <math>b</math> – Width of Gear  <math>N</math> – Speed of Pump</p>
<p><b>2. Theoretical Discharge for Vane Pump:</b></p> $Q_T = \frac{(D_c + D_r)^2 e L N}{4}$	<p><math>D_c</math> – Diameter of Cam Ring  <math>D_r</math> – Diameter of Rotor  <math>e</math> – Eccentricity  <math>L</math> – Width of Rotor</p>
<p><b>3. Bent Axial Piston Pump</b></p> $Q_T = D A N Y \sin \phi ; \sin \phi = \frac{S}{D}$	<p><math>D</math> – Piston circle Diameter  <math>A</math> – Area of Piston  <math>Y</math> – Number of pistons  <math>\phi</math> – Offset angle  <math>S</math> – Piston stroke</p>
<p><b>4. Swash Plate Pump:</b></p> $Q_T = D A N Y \tan \phi$	<p><math>\phi</math> – Offset angle of Swash Plate</p>
<p><b>5. Radial Piston Pump</b></p> $Q_T = 0.5 e Y \pi D^2 N$	

**Volumetric Efficiency:** It indicates the amount of leakage within the pump. This involves considerations such as manufacturing tolerances and flexing of the pump casing under the design pressure operating conditions.

$$\eta_v = \frac{\text{Actual Flow rate produced by pump}}{\text{Theoretical flow rate the pump should produce}} \times 100$$

$$\eta_v = \frac{Q_v}{Q_A}$$

$Q_T$

**Mechanical Efficiency:** It indicates the amount of energy losses that occur due to reasons other than leakages. This includes friction in bearings and between other mating parts. It also includes energy losses due to fluid turbulence.

Theoretical Power required to operate the pump

$$\eta_m = \frac{\text{Actual power delivered to the pump}}{\text{Theoretical Power required to operate the pump}} \times 100$$

$$\eta_m = \frac{P_{QT}}{P_{NT}}$$

$$= \frac{P_{QT}}{2 P_{NT}}$$

**Overall**

**Efficiency:**

$$\eta_o = \eta_v \times \eta_m$$

## HYDRAULIC ACTUATORS

### ACTUATORS:

#### RS:

It is a device used for converting hydraulic energy into mechanical energy. The pressurized hydraulic fluid delivered by the hydraulic pump is supplied to the actuators, which converts the energy of the fluid into mechanical energy. This mechanical energy is used to get the work done.

#### TYPES OF ACTUATORS:

1. Linear Actuators (Hydraulic cylinders)
2. Rotary Actuators (Hydraulic motors)
  - a. Continuous rotary actuators
  - b. Semi rotary actuators

#### HYDRAULIC CYLINDERS:

A hydraulic cylinder is a device, which converts fluid power into linear mechanical force and motion. It usually consists of a movable element, a piston and a piston rod operating within a cylinder bore.

#### TYPES OF HYDRAULIC CYLINDERS:

1. Single acting cylinders
2. Double acting cylinders
3. Telescoping cylinders
4. Double rod cylinder
5. Tandem cylinder

#### SINGLE ACTING CYLINDER:

A single acting cylinder is designed to apply force in only one direction. It consists of a piston inside a cylindrical housing called barrel. Attached to end of the piston is a rod which extends outside. At the other end (Blank end) is a port for the entrance and the exit of oil. A single acting cylinder can exert a force only in the extending direction, as fluid from the pump enters through the blank end of the cylinder. Single acting cylinders do not hydraulically retract. Retraction is accomplished by using gravity or by the inclusion of a compression spring at the rod end.

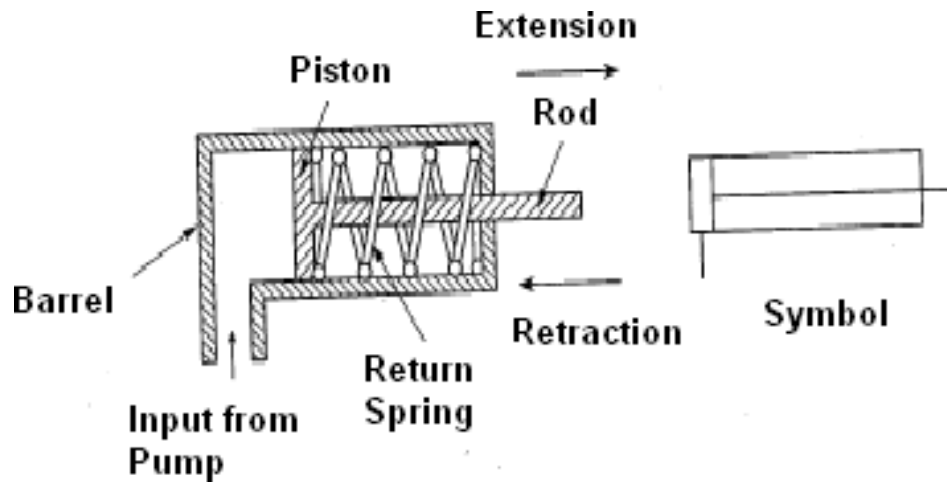

**Advantages and Disadvantages:**

1. The single acting cylinders are very simple to operate, and compact in size.
2. The single acting cylinders with spring return cannot be used for larger stroke length.

**DOUBLE ACTING CYLINDER:**

A double acting cylinder is capable of delivering forces in both directions. The barrel is made of seamless steel tubing, honed to affine finish on the inside surface. The piston which is made of ductile iron contains U cup packing to seal the leakage between the piston and the barrel. The ports are located in the end caps which are secured to the barrel by tie rods. The load of the piston rod at the neck is taken by a rod bearing, which is generally made of brass or bronze.

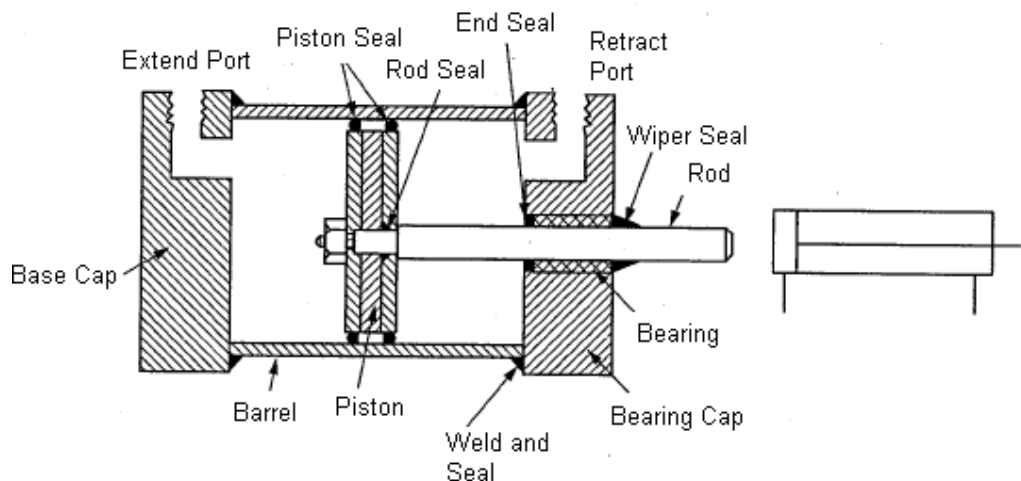

A rod wiper is provided at the end of the neck to prevent foreign particles and dust from entering into the cylinder along with the piston rod. When the fluid from the pump enters the cylinder through port 1, the piston moves forward and the fluid return to the reservoir from the cylinder through port 2. During the return stroke the fluid is allowed to enter the cylinder through port 2 and fluid from the other side of the piston goes back to the reservoir through port 1.

**CYLINDER CUSHIONING:**

As long as the piston is moving in the middle range of the cylinder, nothing will hit the piston head. But, due to the inertia forces of the moving parts at the end of the piston travel, the piston will hit the cylinder head at full speed. To overcome this, the designers provide a cushioning arrangement by which the hydraulic cylinder can be slowly retarded or cushioned, during the last

portion of the stroke. The figure shows the position of the piston at the start of the cushioning action. In this position, the fluid from the pump enters into the rod end of the cylinder moving the piston towards the left. The fluid from the head end of the cylinder flows freely to the reservoir through the fluid port.

As the stroke nears completion, the cushion nose starts entering in the space of the cylinder head. Due to the taper front of the cushion nose, the fluid port path is gradually closed. So the fluid cannot flow through the port or through the passage of check valve.

Now entrapped fluid can escape only through the passage controlled by the needle valve. Thus due to the restricted outflow during the last portion of the stroke, the piston decelerates slowly. By adjusting the needle

rate of deceleration is controlled. For starting the forward stroke of the piston, the fluid is allowed to enter the fluid port. The fluid will now flow from all passages. Thus the full piston area will be subjected to the system pressure.

During deceleration of the load, extremely high pressures will develop within the cylinder cushion. Ideally, the back pressure will be constant over the entire cushioning length. But in practice, the cushion pressure is higher when the piston rod has just entered the cushion.

### SPEED OF A HYDRAULIC CYLINDER:

Every hydraulic cylinder has its own economical and practicable range of speeds. If the speed of the cylinder is increased beyond this limit, the sudden stoppage of the piston will create shock load on the piston head, piston rod and other mechanical parts causing serious damages. The high speed will also create difficulty in the accurate positioning of the movable parts. So at the time of deciding the speed of a hydraulic cylinder, proper care is to be taken in the design stage itself.

The maximum speed of the piston rod is limited by the rate of fluid flow in and out of the

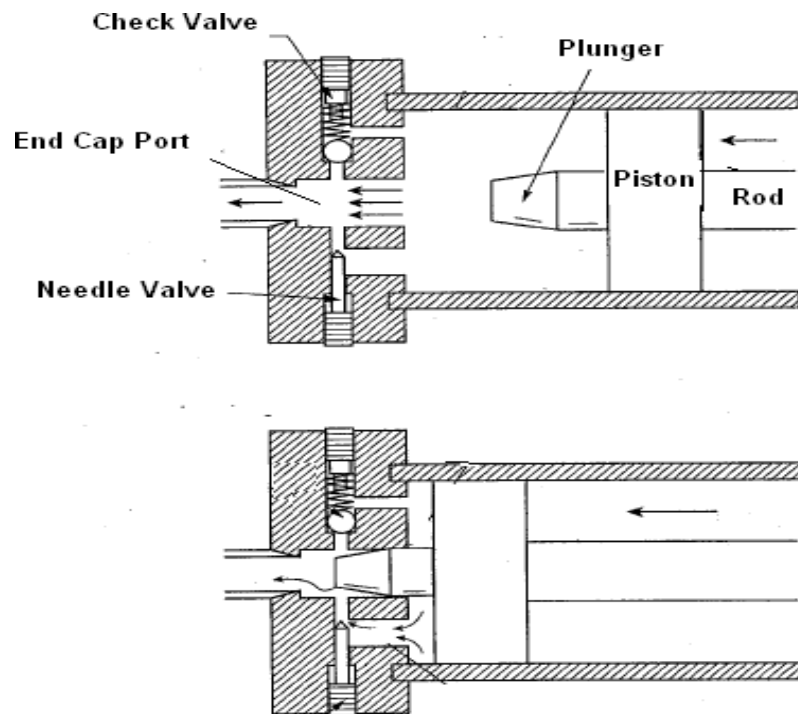



cylinder and the ability of the cylinder to withstand the impact forces which occur when the piston movement is arrested. In an un-cushioned cylinder it is normal to limit the maximum piston movement is arrested. In an un-cushioned cylinder it is normal to limit the maximum piston velocity to 8m/min. This value is increased to 12m/min for a cushioned cylinder and 45m/min is permissible with high speed cylinders. Oversized ports are necessary in cylinders that are used in high speed applications.

**Velocity equations:**

Consider a double acting cylinder D – Diameter of the piston

d – Diameter of piston rod

$$\pi D^2$$

A – Area of Blank end =  $\frac{\pi D^2}{4}$

$$\pi d^2$$

a- Piston rod area =  $\frac{\pi d^2}{4}$

Q – Input flow rate

qE – Flow rate from rod end of the cylinder when extending  
 qR – Flow rate from blank end of cylinder when retracting

□

Rod End Area – (A-a) =  $\frac{\pi (D^2 - d^2)}{4}$

**1. When Piston rod is extending:**

$$Q = qE$$

Piston velocity  $V_E = \frac{Q}{A - a}$

$$= \frac{Q}{\left( \frac{\pi D^2}{4} - \frac{\pi d^2}{4} \right)}$$

Thus  $qE = \frac{Q}{A} = \frac{Q}{\frac{\pi D^2}{4}}$

Thus as the piston rod is extending, the flow rate of the fluid leaving the cylinder is less

than the flow rate of fluid entering the cylinder.

**2. When piston rod is retracting:**

$$\text{Piston velocity } V_R = \frac{Q}{A - a} = \frac{q_R}{A - a}$$

$$= \frac{Q}{A - \frac{\pi d^2}{4}} = \frac{q_R}{A - \frac{\pi d^2}{4}}$$

$$\text{Thus } q_R = Q \frac{A - a}{A} = Q \frac{D^2 - d^2}{D^2}$$

Thus when the piston rod is retracting, the rate of fluid leaving the cylinder is greater than the flow rate of fluid entering the cylinder.

**SPECIAL TYPE CYLINDERS:**

**DOUBLE ROD CYLINDER:**

It is a cylinder with single piston and a piston rod extending from each end. This cylinder allows work to be performed at either or both ends. It may be desirable where operating speed and return speed are equal.

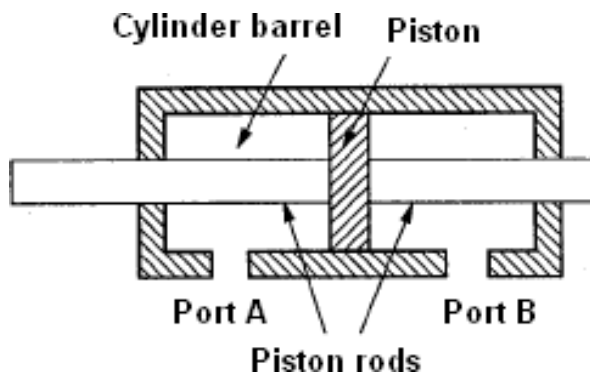

**TANDEM CYLINDER:**

Its design has two cylinders mounted in line with pistons connected by a common piston rod. These cylinders provide increased output force when the bore size of a cylinder is limited. But the length of the cylinder is more than a standard cylinder and also requires a larger flow rate to achieve a speed because flow must go to both pistons.

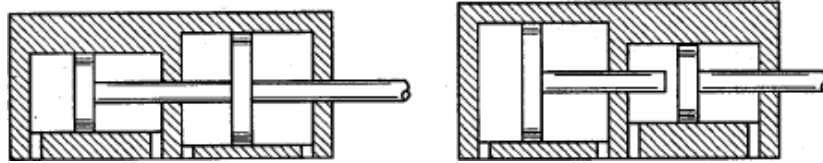

**TELESCOPING CYLINDER:**

They are used where long work strokes are needed. A telescoping cylinder provides a relatively long working stroke for an overall reduced length by employing several pistons which telescope into each other.

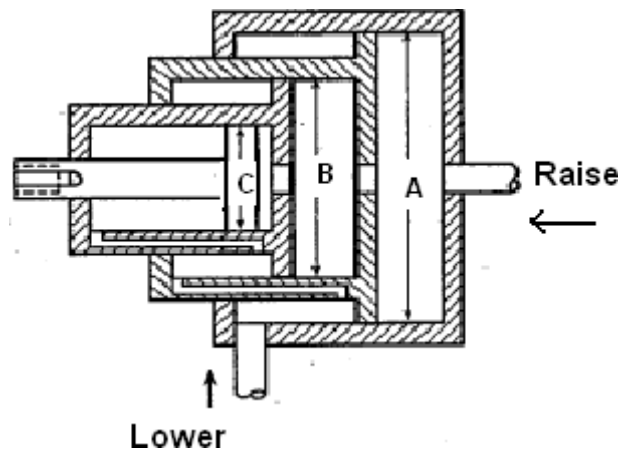

Since the diameter A of the ram is relatively large, this ram produces a large force for the beginning of the lift of the load. When ram A reaches the end of the stroke, ram B begins to move. Now ram B provides the required smaller force to continue raising the load. When ram B reaches the end of its stroke, then ram C moves outwards to complete the lifting operation. These three rams can be retracted by gravity acting on the load or by pressurized fluid acting on the lip of each ram.

**TWO STAGE DOUBLE ACTING TELESCOPING CYLINDER:**

**Retraction stroke:** During the retraction stroke, the fluid is fed into the first stage annulus via

retract port A. therefore the first stage piston is forced to the left until it uncovers the fluid ports connecting this with the second stage annulus. This, in turn, moves the larger piston to the left until both the pistons are fully retracted into the body of the cylinder.

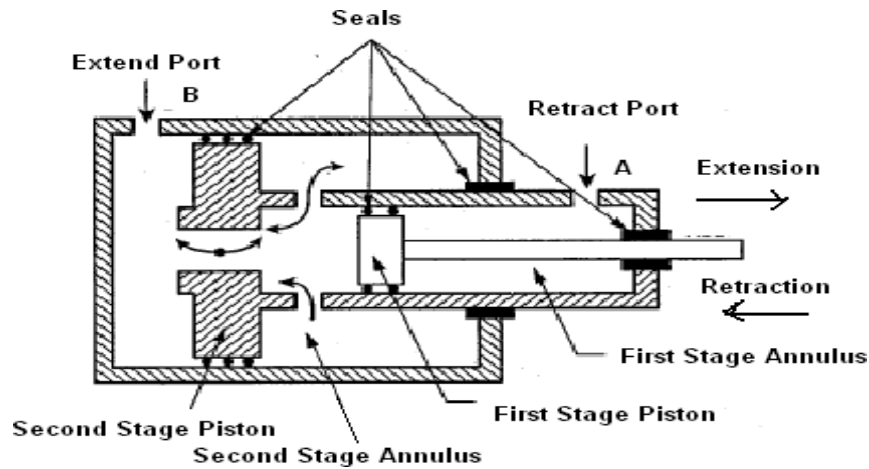

**Extension Stroke:** During the extension stroke, the fluid is fed through the extend port B. Now the fluid forces both pistons to the right until the cylinder is fully extended.

#### **MOUNTING CONFIGURATIONS:**

The type of mountings on cylinder is numerous, and they can accommodate a wide variety of applications. The most common mountings are lugs, flange, trunnion, clevis and extended tie rods. One of the important considerations in selecting a particular mounting style is whether the major force applied to the load will result in tension or compression of the piston rod. The ratio of rod length to diameter should not exceed 6:1 proportion at full extension. This helps to prevent the rod from buckling due to compression or tensile shock forces.

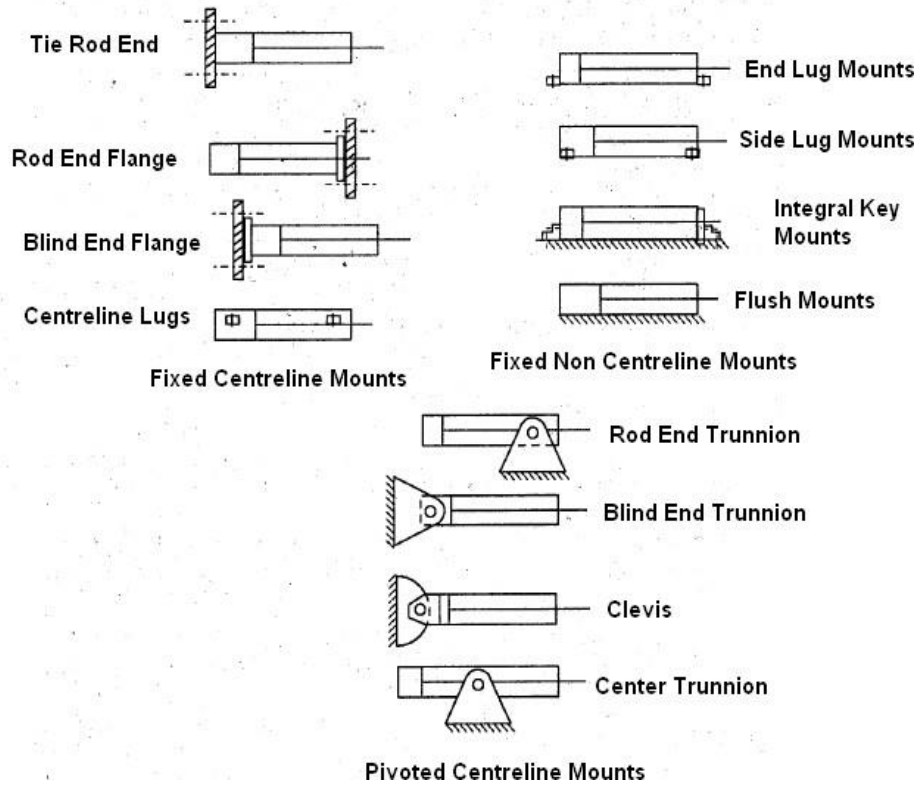

Alignment of the rod with the resistive load is another important consideration while selecting cylinder mounts. Misalignment or non axial loading also tends to place unnecessary loads on the rod and the rod guides, bushes or bearings. Due to the immense loads and the extreme forces induced by the rod there are large stresses on the rod at full extension. Centre lugs, centre trunnions and clevis arrangements tend to help keep the rod or shaft in line with the load.

**Fixed centerline mounts:** These are used for thrust that occur linearly or in the centerline with the cylinder. Proper alignment is essential to prevent compound stresses that may cause excessive friction and bending as the piston rod extends. Additional holding strength may be essential with long stroke cylinders.

**Fixed non-centerline mounts:** These are convenient where exceptionally heavy linear thrusts are encountered. Generally, integral keys or pins are used if excessive hydraulic shock is expected. This helps to relieve shear loads. Since the cylinder has to expand and contract with temperature changes, only one end should be keyed or pinned.

**Pivoted centerline mounts:** These are used to compensate for thrusts that occur in multiple planes or if the attached load travels in a curved path. Ball joints, trunnions and clevis mounts allow thrust to be taken up along the cylinder centerlines.

#### **GRAPHIC SYMBOLS FOR LINEAR ACTUATORS:**



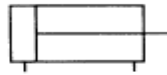

**Double Acting Cylinder**

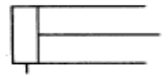

**Single Acting Cylinder**

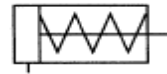

**Single Acting with Spring return**

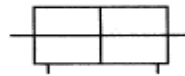

**Double Rod Double Acting**

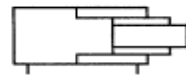

**Telescopic Double Acting**

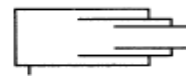

**Telescopic Single Acting**

**HYDRAULIC MOTORS:**

A hydraulic motor converts fluid power into mechanical power in the form of rotational motion. Motors perform the opposite function of the pump, which converts mechanical power from an electric motor or engine into fluid power. Motors take pump flow and pressure as their input and output rotational motion and torque. Motor displacement is the volume. Pump displacement is the volume of the pump outputs per revolution of the pump shaft, a similar concept. Like pump motors can be fixed or variable displacement. Increasing the displacement of a motor decreases its speed because it requires more fluid to turn it each revolution. Increasing displacement increases torque output because more area within the motor is subjected to pressure. Decreasing motor displacement increases speed and decreases torque.

Hydraulic motors are most commonly gear, vane or piston type. All have a construction similar to the hydraulic pump of the same type. They also have similar properties. Gear motors are the least efficient, most dirt tolerant and have the lowest pressure ratings of the three. Piston motors are the most efficient, least dirt tolerant and have the highest pressure ratings. Vane and piston motors can be fixed or variable displacement like vane and piston pumps. Gear motors like gear pump are not available with variable displacement.

**GEAR MOTOR:**

The operation of gear motor is shown in the figure. One of the gears is keyed to an output shaft, while the other is simply an idler gear. Pump flow and pressure are sent to the inlet port of the motor. The pressure is then applied to the gear teeth, causing the gears and the output shaft to rotate. The pressure builds until enough torque is generated to rotate the output shaft against the load. Most gear motors are bi-directional the direction of rotation can be reversed by simply reversing the direction of flow.

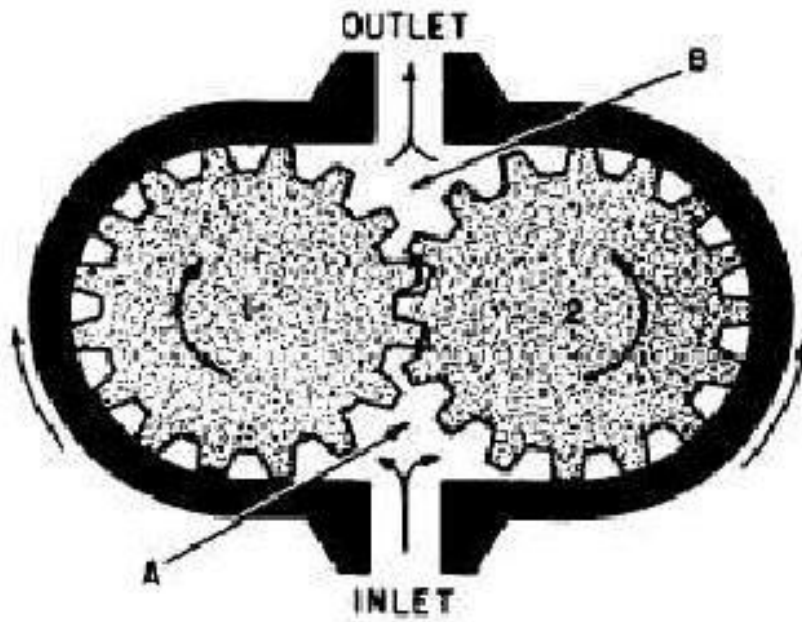

## VANE MOTORS:

In this type of motors the pump flow and pressure are applied to the vanes and the output shaft is rotated. The figure shows the balanced vane type motor. Recall from the discussion on vane pumps that balanced means that pressure is applied on both sides of the shaft resulting in no net force on the bearings.

This increases the maximum operating pressure and drive speed at which the motor can operate. The vanes extend and retract twice per revolution of the rotor, which necessitates the use of two inlet and

two outlet chambers. These chambers are combined into one common inlet and one common outlet within the motor housing. Most of the vane motors are bidirectional.

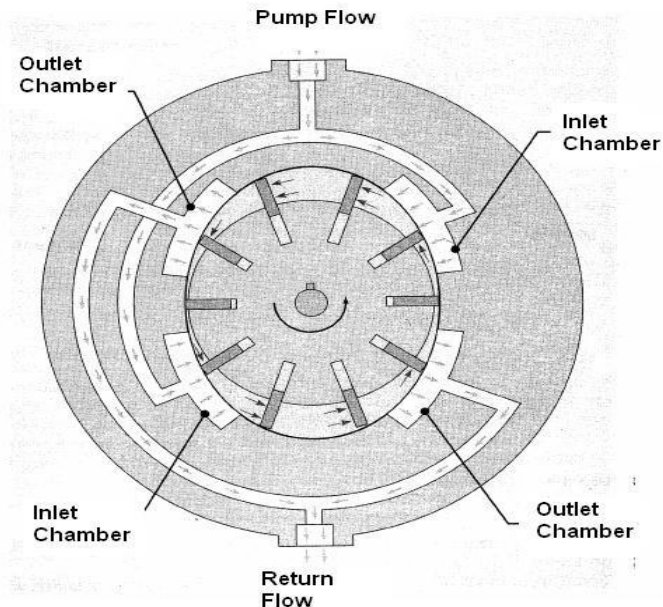

## PISTON TYPE MOTORS:

Piston motor develops an output torque at its shaft by allowing hydraulic pressure to act on pistons. Piston designs may be either axial piston type or radial piston type.

Axial piston motors:

**Swash plate or bent axis type:** It consists of a port plate, cylinder barrel, pistons, shoe plate, swash plate and a shaft. The arrangement is similar to a swash plate type pump. When fluid pressure acts on a piston, a force is developed which pushes the piston out and causes the piston shoe to slide across the swash plate surface. As the piston shoe slides, it develops a torque attached to the barrel.

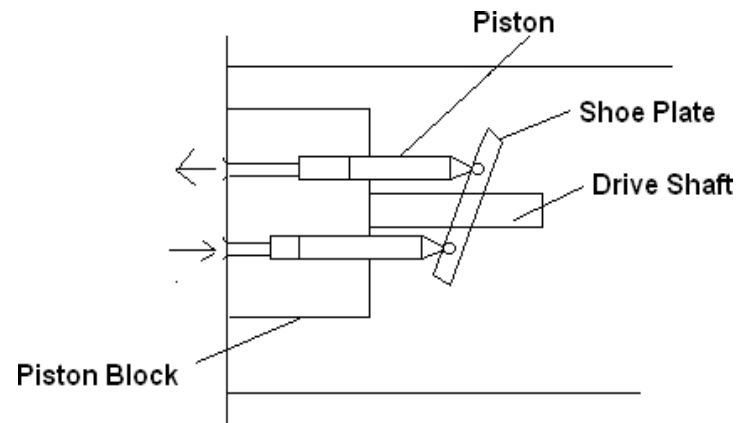

### Swash Plate Type

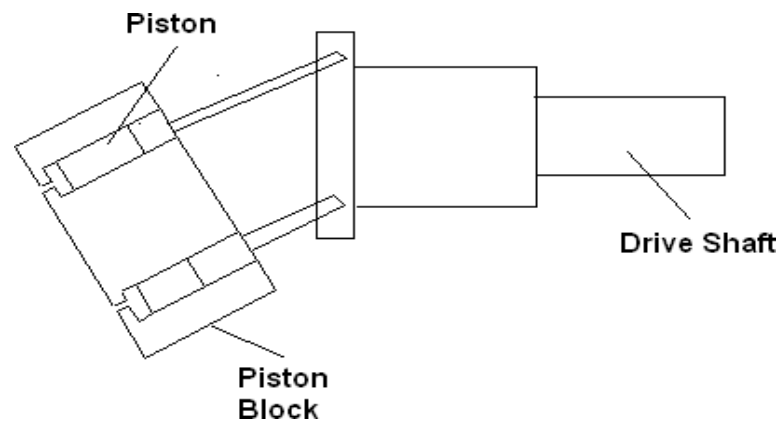

### Bent Axis Type

The amount of torque depends on the angle of slide caused by the swash plate and the pressure in the system. Since the swash plate angle controls the stroke in pistons of an axial piston motor, changing the angle will alter the stroke and motor displacement. The operating principle of an **bent axis motor** is similar to swash plate type. The angle of the cylinder block assembly with respect to drive shaft determines the stroke or motor displacement. Both these motors are used in high speed application only.

### SEMI ROTARY ACTUATORS:

These are used to convert fluid pressure energy into torque which turns through an angle limited by the design of the actuator. With the majority of designs, the angle of rotation is within 360 degrees although it is possible to considerably exceed this when using piston operated actuators.

### VANE TYPE ACTUATORS:

Vane type semi rotary actuator consists of one or two vanes connected to an output shaft which rotates when hydraulic pressure is applied to one side of the vanes. A single vane is limited

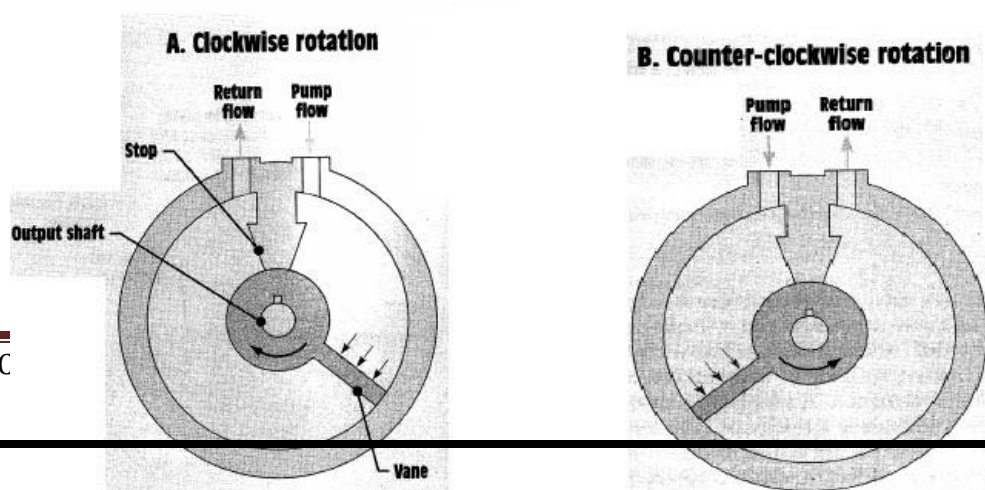

to 280° rotation and a double vane unit to approximately 100°. Power in a two vane design is doubled.

### **Single Vane Semi Rotary Actuators**

There will always be some internal fluid leakage across the vanes and these increases with the operating pressure as the viscosity of the working fluid decreases. This causes problems where a smooth speed control of the rotary motion is required. So, for the applications of vane type actuators, the manufacturer's recommendations regarding the operating pressure and type of fluid must be followed.

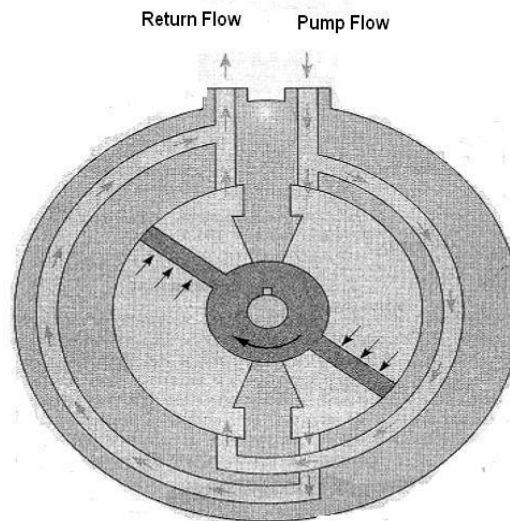

### **Double Vane Semi Rotary Actuators**

The maximum torque obtainable from the currently available single vane unit is approximately  $40 \times 10^3$  Nm and for double vane unit is  $80 \times 10^3$  Nm.

### **PISTON TYPE SEMI ROTARY ACTUATORS:**

### **RACK AND PINION SEMI ROTARY ACTUATOR:**

In this design, the cylinder drives a pinion gear and the rack is an integral part of the piston rod. The angle of rotation depends upon the stroke of the cylinder, rack and the pitch circle diameter of the pinion. The start and finish of the stroke is adjusted by means of an internal stop. The output torque available from the rack and pinion type is in an excess of  $80 \times 10^3$  Nm at a pressure of 210 bar.



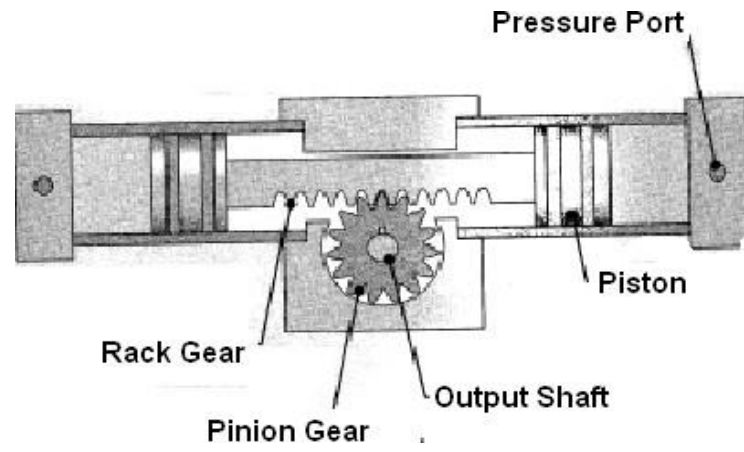

**LEVER ARM SEMI ROTARY ACTUATOR:**

A double acting cylinder can be made to generate rotary motion by using a lever arm. The angle of rotation will be less than  $180^\circ$ . The output is the product of {Piston thrust  $\times$  Sin  $\phi$   $\times$  length of lever}.

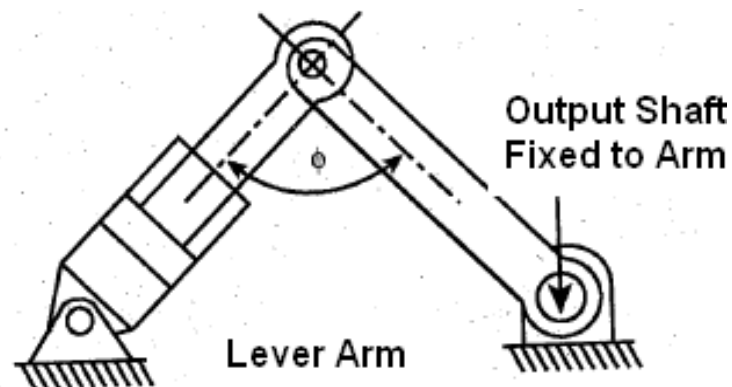
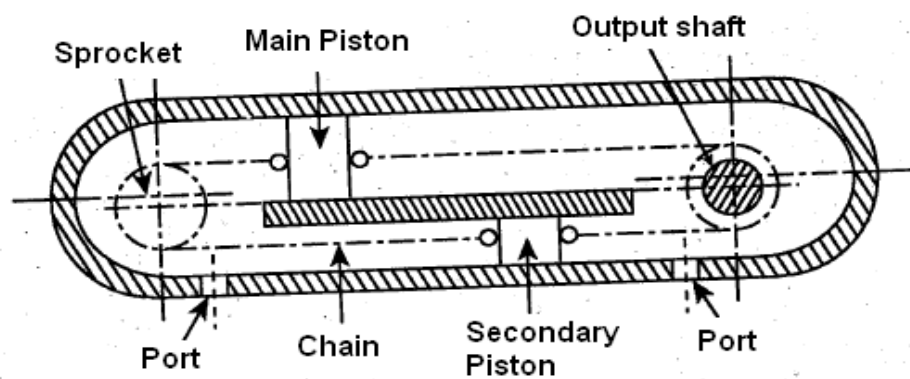
**CHAIN AND SPROCKET SEMI ROTARY ACTUATOR:**

In this design an endless chain and sprocket is used and it is suitable for multi revolution applications. The chain is anchored to two pistons, one large and the other small, which when in their respective bores, separate the halves of the unit. The large cylinder is the power cylinder and the small cylinder is the chain return or seal cylinder.

The idler is automatically a tensioned one, so a constant tension is maintained. Pressure is applied to one port of the actuator. The larger piston moves away from the port due to the differential area of the two pistons. Movement of the larger piston pulls the chain, causing the sprocket and output shaft to rotate.

**HELICAL SCREW SEMI ROTARY ACTUATOR:**

This type consists of a cylinder in which the piston is prevented from rotating by guide rods. The piston rod and the piston contain a helical groove and they mate together analogous to a screw and a nut. As the piston is driven along the barrel, it causes the rod to rotate. Because of the difficulty in providing a hydraulic seal between the piston and rod, this design is limited to low pressure applications. The self locking helix angle of the piston and rod eliminate the possibility of external torque causing any rotary movement of the piston rod.

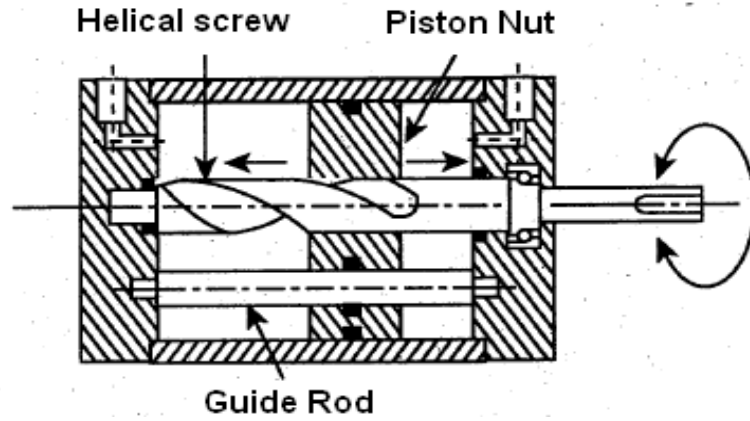

Fixed Displacement  
Uni-directional

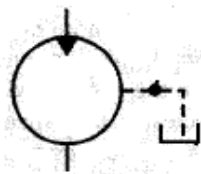

Fixed Displacement  
Bi-directional

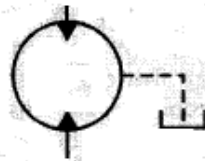

Variable Displacement  
Bi-directional

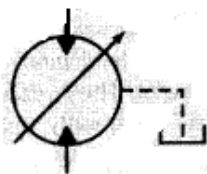

Limited Rotation  
bi-directional



**GRAPHIC SYMBOLS:**

**UNIT III****HYDRAULIC CIRCUITS AND THEIR DESIGN**

**INTRODUCTION:** A fluid power system can be broken down into three segments. The power input segment consisting of the prime mover and the pump. The control segment consisting of valves that control the direction, pressure and flow rate. The power output segment, consisting of the actuators and the load. This unit is devoted to each of the following categories of control valves.

1. Directional control valves
2. Pressure control valves
3. Flow control valves

DCVs control the direction of flow in a circuit, which among other things; can control the direction of the actuator. PCVs control the pressure level, which controls the output force of a cylinder or the output torque of a motor. FCVs control the flow rate of the fluid which controls the speed of the actuators.

**VALVE CONFIGURATION:** There are the essential types of control valves based on their configuration or modes of operation. They are

1. Poppet or Seat Valves
2. Sliding Spool Valves
3. Rotary Spool Valves

**POPPET OR SEAT VALVES:**

The Figure shows the construction of the poppet valve. Normally this valve is in the closed condition and hence there is no connection between port 1 and port 2. In poppet valves, balls are used in conjunction with valves seats to control the flow.

When the push button is depressed the ball is pushed out of its seats and hence the flow is permitted from port 1 to port 2. When the push button is released spring and fluid pressure force the ball back up against its seat

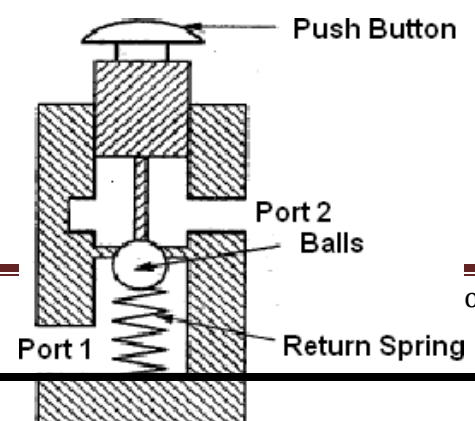

and so closes off the flow.

These types of valves are simple in design and less expensive. The force required to operate the poppet valves are more, so they are suitable mostly for low pressure applications.

### **SLIDING SPOOL VALVES:**

These types of valves are most frequently used in hydraulic system. A spool moves horizontally within the valve body to control the flow. The raised areas called lands block or open port

to give the required operation. In first position the port 1 and port 2 is opened and port 3 is blocked so the flow is permitted between ports 1 and 2. In the second position the ports 2 and 3 are open and port 1 is blocked so the flow is permitted between 2 and 3.

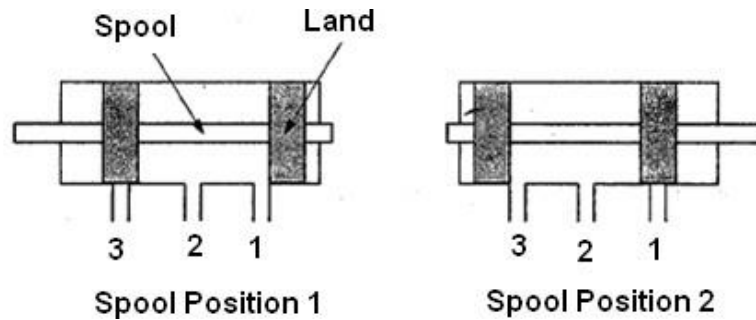

By using this type of valves different operations can be achieved with a common body and different spool. It is used for high pressure applications.

**ROTARY SPOOL VALVES**

These valves have a rotating spool which engages with ports in the valve casing to give the required operation. The Figure shows the cut section of a rotary spool valve. When the spool rotates, it opens and closes ports to allows and prevent the fluid flow through it. There are four ports 1, 2, 3, and 4. In the first position there is flow between 1 and 3, 2 and 4. In second position flow between 2 and 3, 1 and 4. In third position all the ports are blocked by the spool and there is no flow.

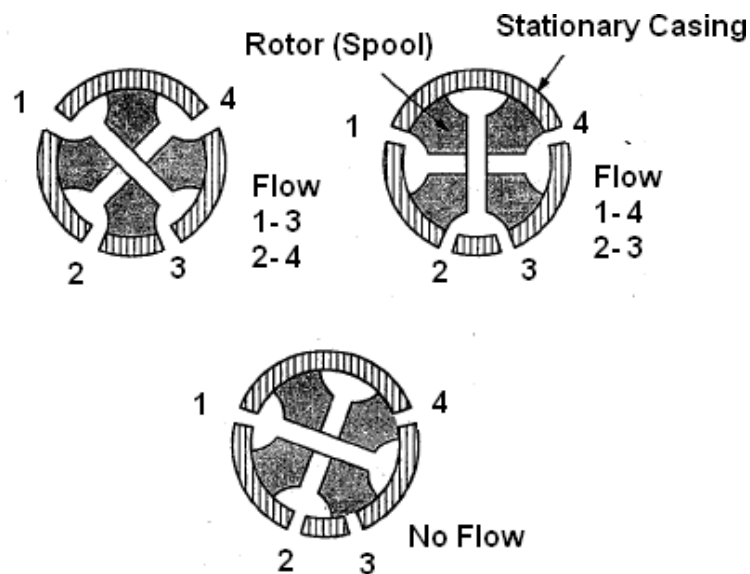

**DIRECTION CONTROL VALVES**

These valves are used to control the direction of flow in a hydraulic circuit. According to the construction of internal moving parts it is classified as poppet type and sliding spool type. It may be further classified as one way, two way, three way and four way valves, depending upon the number of port connections available. On the basis of actuating devices, it can be classified as manually operated, mechanically operated, solenoid operated and pilot operated.



### CHECK VALVES

The simplest direction control valve is a check valve. It allows flow in one direction and blocks flow in the opposite direction. It consists of a ball with a light bias spring that holds the ball against the valve seat. Flow coming into the inlet pushes the ball off the seat against the light force of the spring and continues to the outlet.

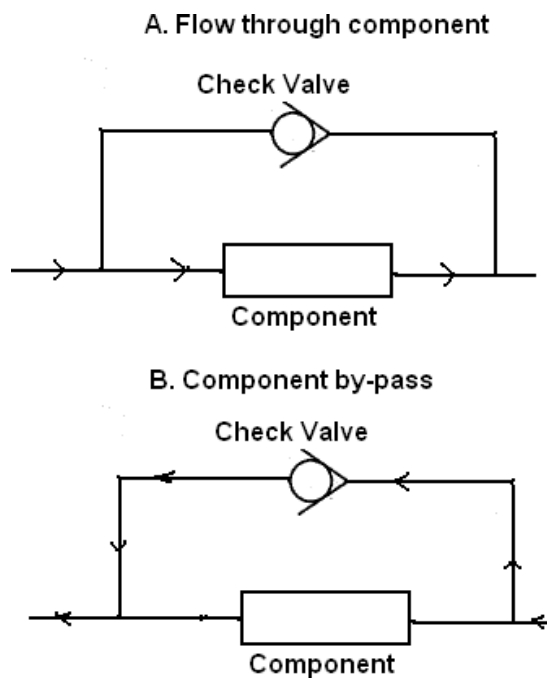
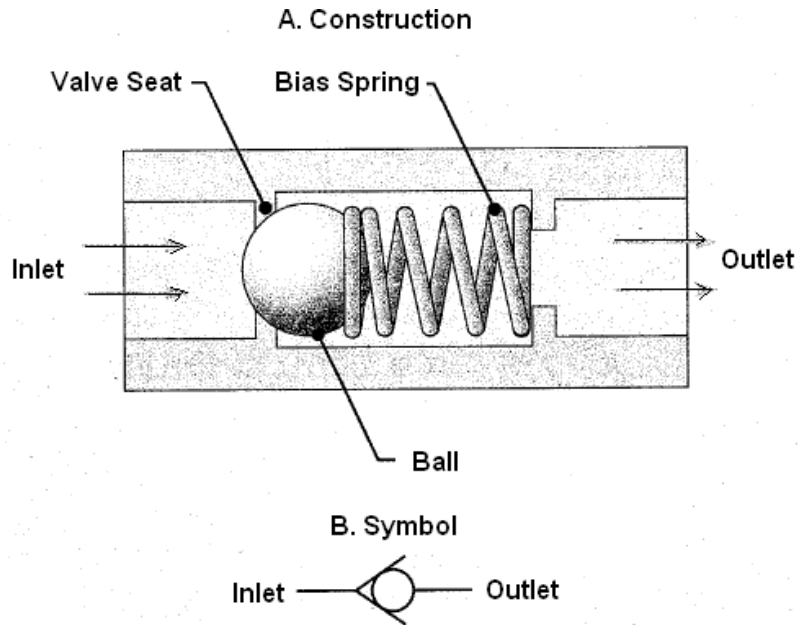

### **Application of Check Valve**

If flow tries to come in from left it cannot pass through the check valve. It is therefore forced to go through the component. When the flow comes in from the right, however the flow goes through the check valve and the component is bypassed. This occurs because the check valve is designed to have less resistance to flow than the component in this direction.

**PILOT OPERATED CHECK VALVE**

One commonly used type is the pilot to open check valve. Pilot lines are hydraulic lines that are used for control purposes. They typically send system pressure to component, so that the component can react to pressure changes. The free flow in the normal direction from a port A to port B is achieved in a usual manner. But the reverse flow is blocked as the fluid pressure pushes the poppet into the closed position. In order to permit the fluid flow in the reverse direction that is from port B to port A, a pilot pressure is applied through the pilot pressure port. The pilot pressure pushes the pilot piston and the poppet down. Thus the fluid flow in the reversed direction is also obtained. The purpose of the drain port in the circuit is to prevent oil from creating a pressure building in the bottom of the pilot piston. The pilot lines are shown in dashed lines.

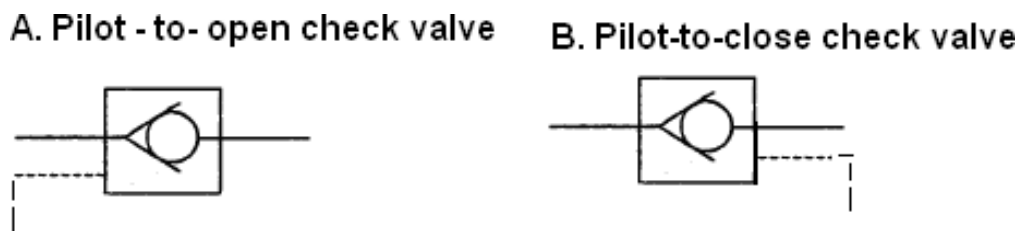

**Symbols for Pilot Operated Check Valve**

**TWO WAY DIRECTIONAL CONTROL VALVE**

A spool valve consists of a cylindrical spool that slides back and forth inside the valve body to either connect or block flow between ports. The larger diameter portion of the spool, the land, blocks flow by covering a port. This particular valve has two ports, labeled P and A. P is connected to the pump line and A is the outlet to the system.

'Figure A' shows the valve in its normal state and its corresponding symbol. The valve is held in this position by the force of the spring. In this position, the flow from the inlet port P is blocked from going to the outlet port A.

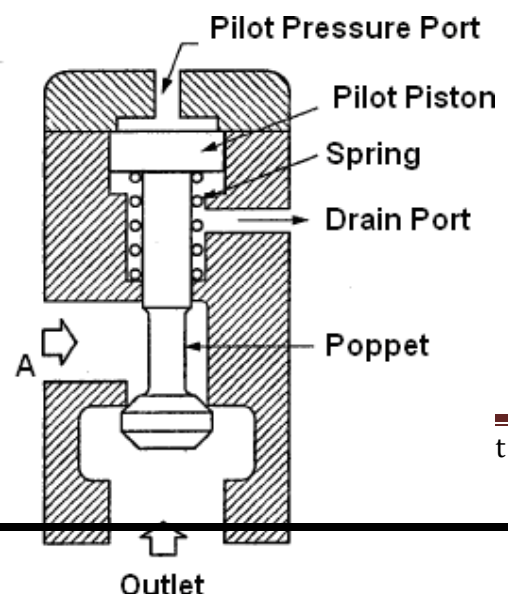

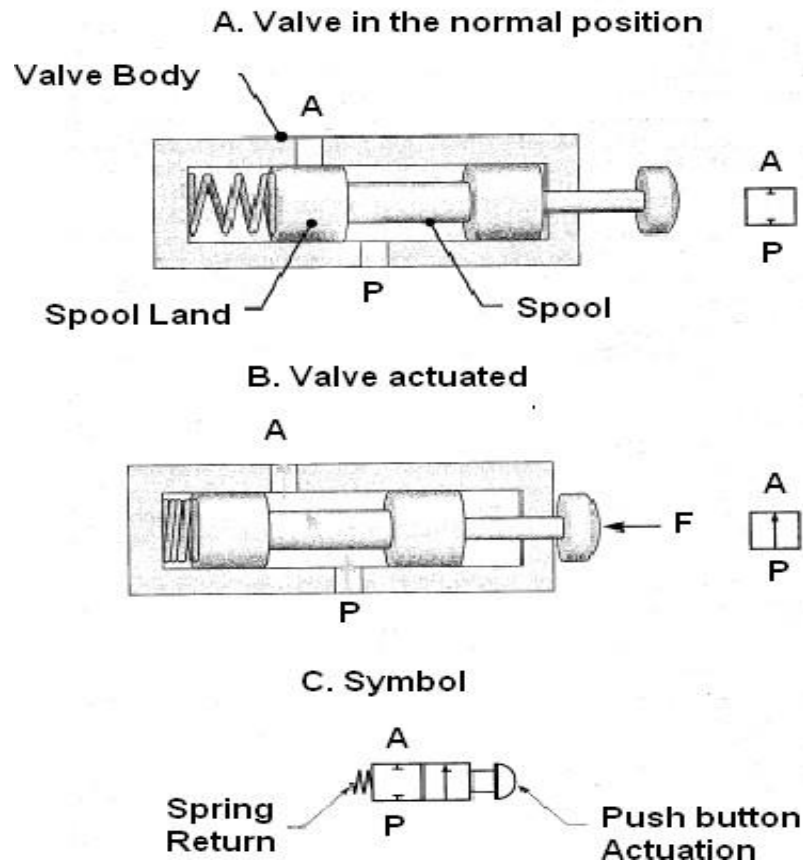

### Two way, Two position normally closed DCV

'Figure B' shows the valve in its actuated state and its corresponding symbol. The valve is shifted into this position by applying a force to overcome the resistance of the spring. In this position, the flow is allowed to go to the outlet port around the smaller diameter portion of the spool. The complete symbol for this valve is shown in 'Figure C'. The symbol has two blocks, one for each position of the valve. Valves may have more than two positions. The spring is on the closed position side of the symbol, which indicates that it is a normally closed valve. The symbol for the method of actuation is shown on the opposite side of the valve. In this case, the valve is push button actuated. Thus, the graphic symbol in 'Figure C' represents a two way, two positions, normally closed DCV with push button actuation and spring return.

The below Figure shows the example of an application for a two way valve. Here pair of two way valves is used to fill and drain a vessel. Although two tanks are shown in this schematic, there may in fact be only one tank in the actual system. When valve1 and valve2 are in the closed position then the line from pump and tank are blocked to hold the fluid in the vessel. When the valve1 is

shifted to the open position and valve 2 remains closed. This will fill the vessel.

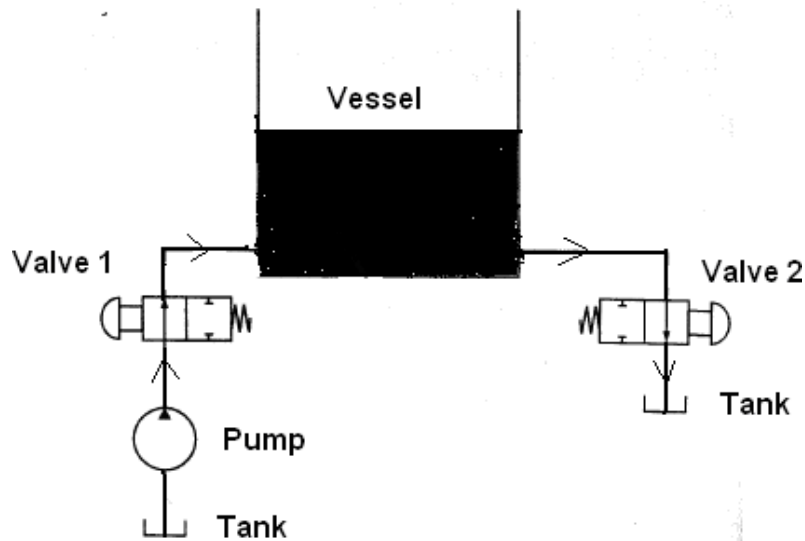

**Application of Two way DCV valves**

When valve2 is shifted to the open position and valve2 remains closed. This will drain the vessel. The above figure shows that valve1 and valve2 are in open position so that fluid is filled and drain from the vessel. There are other types of construction for two way valves in addition to the spool type are ball valves and gate valves.

**THREE WAY DIRECTION CONTROL VALVES**

As discussed earlier two way valves are used to start and stop fluid flow in a particular line.

They can either allow or block flow from a pump to an outlet line for example. Three way valves also either block or allow flow from an inlet to an outlet. They also allow the outlet to flow back to the tank when the pump flow is blocked, while a 2 way does not. A three way valve have three ports a pressure inlet port (P), an outlet to the system (A), and a return to the tank (T). In its normal position, just as with the two way DCV, the valve is held in position with spring.

**A. Valve in the normal position**

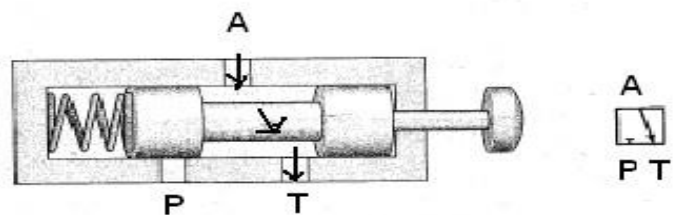

**B. Valve actuated**

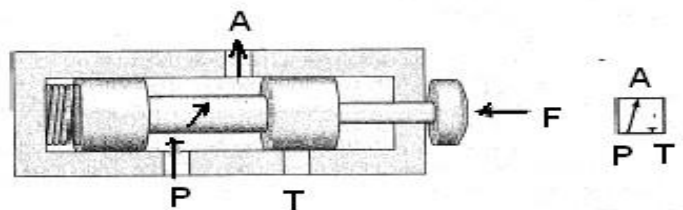

**C. Symbol**

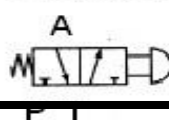

In the normal position 'Figure A' the pressure port (P) is blocked and the outlet (A) is connected with the tank (T). This depressurizes or vents the outlet port.

In the actuated position the pressure port is connected with the outlet and the tank

**Three way, Two position normally closed DCV**

port is blocked. This sends flow and pressure to the system. The spring is shown on the normal side of the valve symbol and the actuation type is shown in opposite side by push button. The symbol indicates that this is a three way two position normally closed DCV with push button and spring return.

The most common application for a three way valve in a hydraulic circuit is to control a single acting cylinder. Part A shows the valve in normal position in which pressure port is blocked and the outlet is return to the tank. This allows the force of the spring to act on the piston and retract the cylinder. The cylinder will remain retracted as

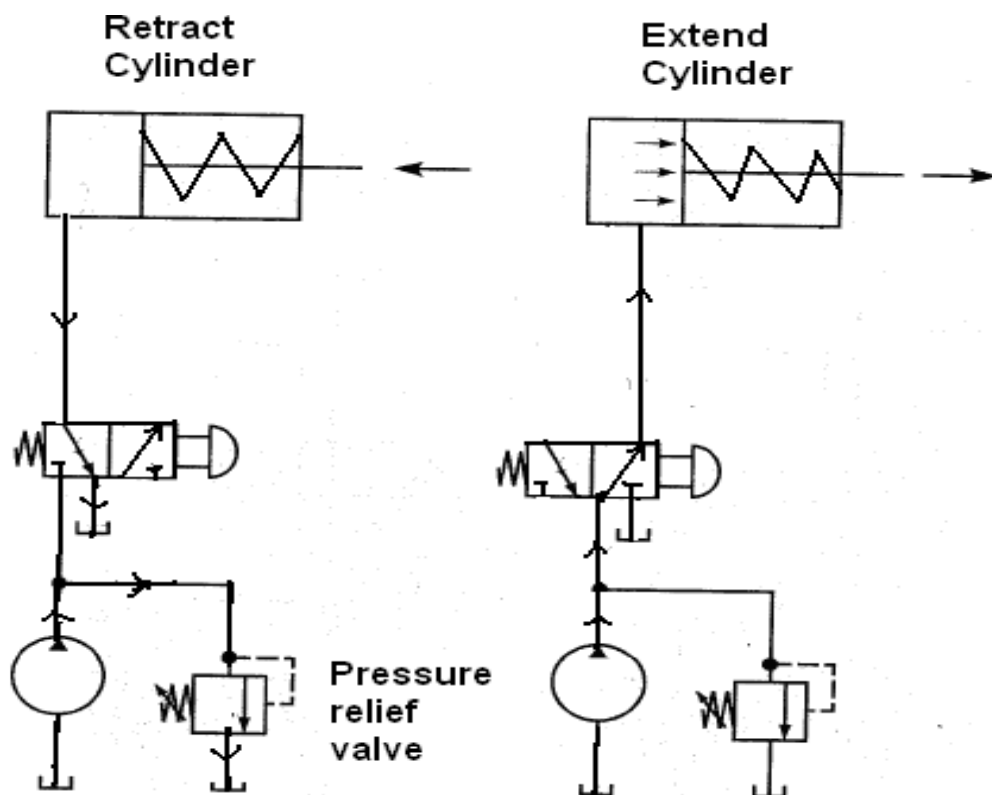

### Application of Three Way Two Position DCV

long as the valve is in this position. In part B the valve is shifted so that the pressure port is connected to the outlet and the tank port is blocked. This applies pump flow and pressure to the piston and extends the cylinder against the relatively light force of the spring. A two way valve could not be used in this application. It would not allow the cylinder to retract when it is in the closed position because the closed position of a two way does not have a return to the tank. A pressure relief valve, a device that limits the maximum pressure in a hydraulic circuit, is included



in the previous circuit. These valves are required components in every hydraulic system. The importance of the pressure relief valves are discussed in upcoming topics.

The next figure shows application of three way three position DCV using gravity return type single acting cylinder. A third valve position called neutral may be desirable for this application. This position shown as the center position in the symbol blocks all the three ports. This holds the cylinder

in a mid-stroke position because the hydraulic fluid, which is relatively incompressible, is trapped between the valve and the cylinder. Many cylinder applications require this feature. This introduces another type of actuation manual lever and detent. A detent is a mechanism that holds the valve in any position into which it is shifted. Detented valves have no normal position because they will remain indefinitely in the last position indicated.

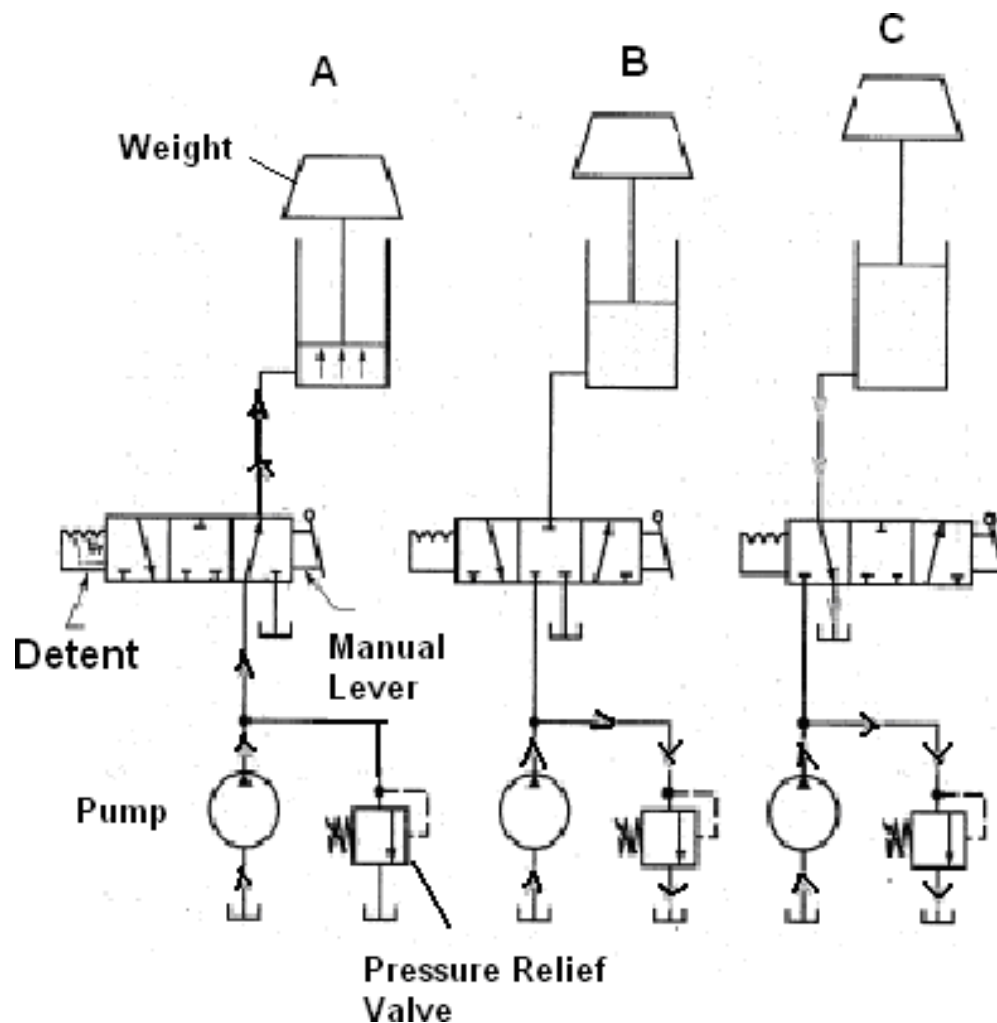

### Application of Three way three position DCV

(A) Extend Cylinder (B) Hold Cylinder (C) Retract Cylinder

### FOUR WAY DIRECTIONAL CONTROL VALVES

Four way valves are the most commonly used directional control valves in hydraulic circuits because they are capable of controlling double acting cylinders and bidirectional motors. Figure shows the operation of a typical four way, two positions DCV. A four way has four ports, usually labeled P, T, A and B. P is the pressure inlet and T is the return to tank. A and B are outlets

to the system. In the normal position, pump flow is sent to outlet B and outlet A is connected to the tank. In the actuated position, pump flow is sent to port A and port B is connected to the tank. Four way DCV control two flows of fluid at the same time, while two way and three way DCV control only one flow at the time.

The most common application for a four way DCV is to control a double acting cylinder as shown in below Figure. When the valve is in the normal position, the pump line is connected to the rod end of the cylinder and the blind end is connected to the tank . The cylinder will therefore retracted, the pump flow will go over the pressure relief valve back to the tank, as it must whenever the pump flow cannot go to the system. In Figure B, the pump line is connected to the blind end of the cylinder and the rod end is connected to the tank. This will cause the cylinder to extend. When the cylinder is fully extended, pump flow will again go over the pressure relief valve to the tank.

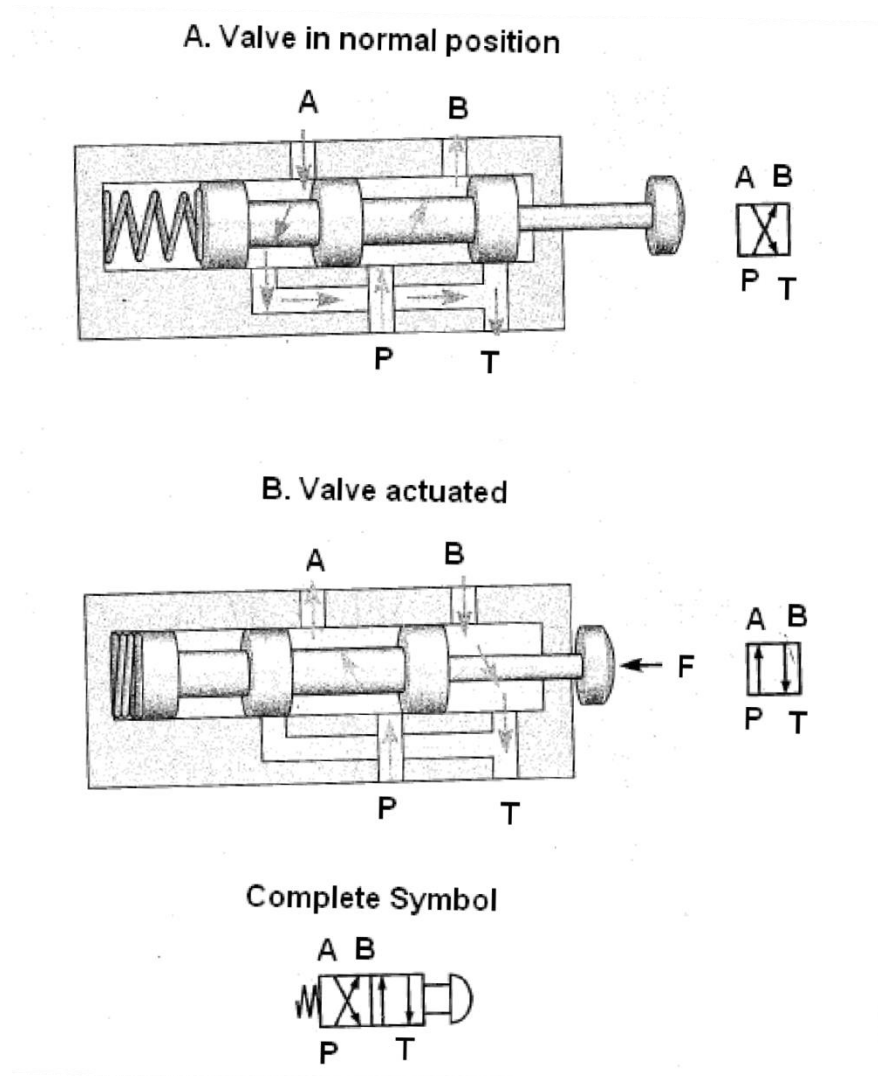

**Four way, Two position DCV**

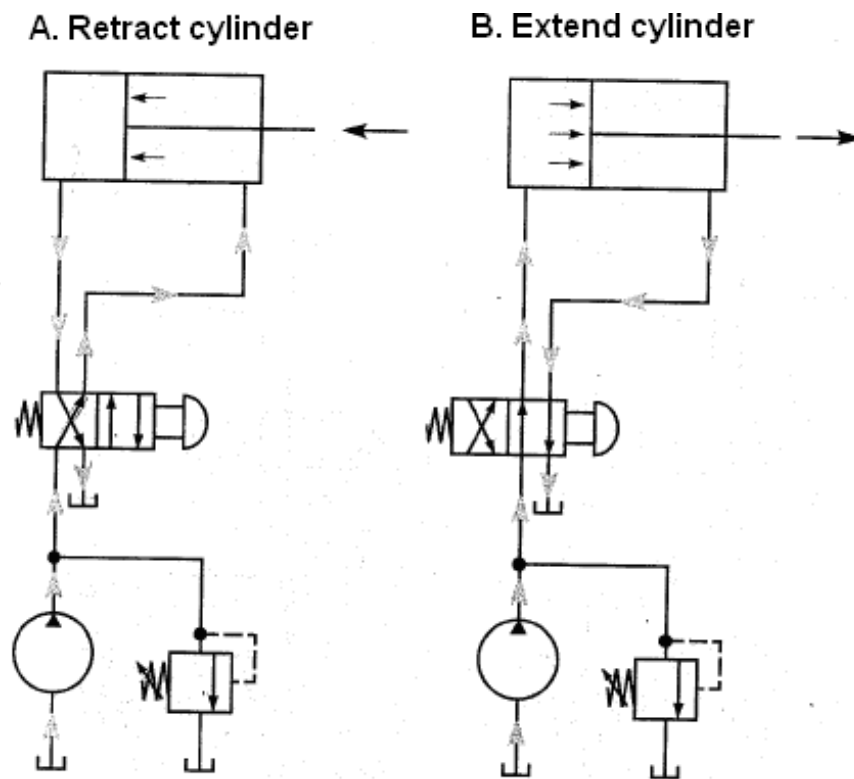

**Application of Four way, Two position DCV**

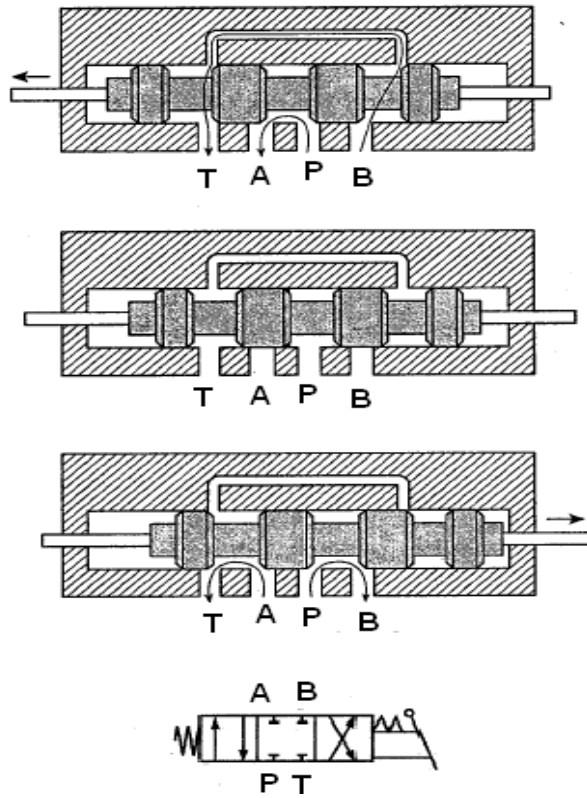

**Four way, Three position DCV**

**SHUTTLE VALVES**

These valves allow two alternate flow sources to be connected to one branch circuit. They have two inlets (P1 and P2) and one outlet (A). Outlet A received flow from whichever inlet is at a higher pressure. If the Pressure at P1 is greater than that at P2, the ball slides to the right and allows P1 to send flow to outlet A. If the pressure at P2 is greater than at P1, the ball slides to the left and P2 supplies flow to outlet A. The Figure shows a circuit that utilizes a shuttle valve. This circuit allows either of two three way buttons to operate a single

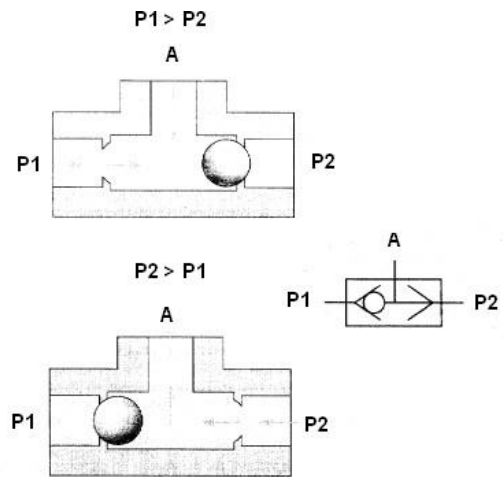

acting cylinder. 'Figure A' shows both three ways in their normal position. The cylinder is vented to the tank and will remain retracted under the force of the spring. In 'Figure B' three way number 1 is shifted and pump flow is sent to the cylinder through the path shown.

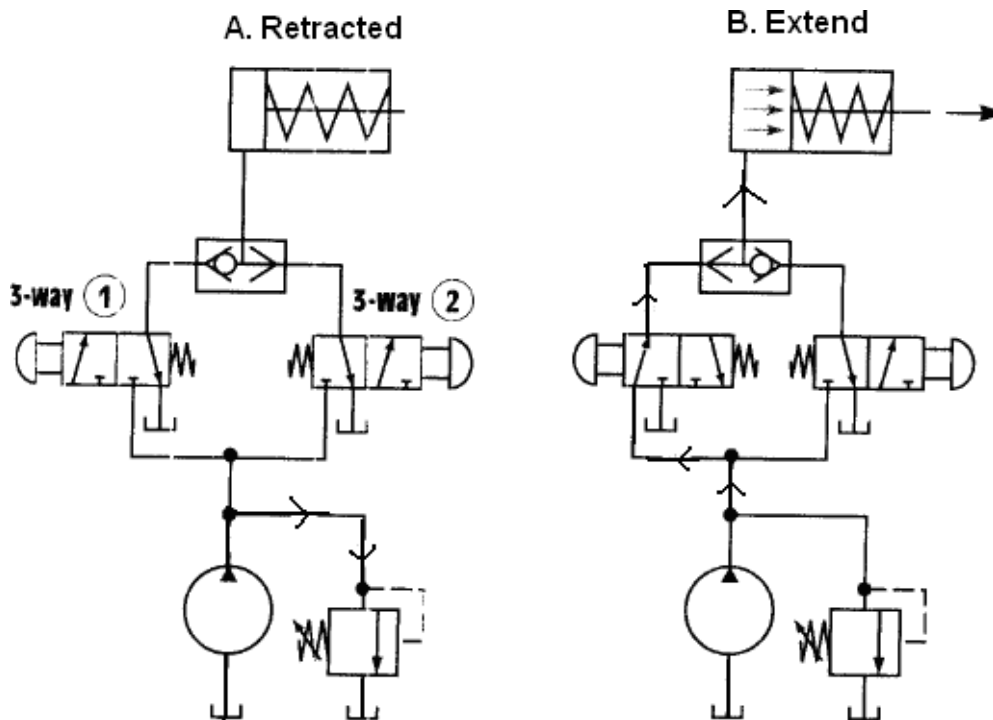

**Shuttle Valve Circuit**

**DIRECTIONAL CONTROL VALVE ACTUATION**

Various methods used to shift the valve are shown in Figure. All shown controlling a spring return four way two position valve. Manual lever is a popular method of actuation for DCVs used in mobile equipment applications such as back hoes, bulldozers and farm equipment. Push button actuation is more prevalent in industrial applications.



Foot pedal actuation, which could be used in an application in which hands free shifting of the DCV is required. Cam actuated valves shift when depressed by some mechanical component of the machine. Pilot operated valves are shifted with system pressure. As stated earlier, pilot operated check valves use system pressure to hold a check valve open or closed when pressure is applied to the pilot line. Solenoid actuated DCV valves are shifted using electrical current, which induces a magnetic force that shifts the valve spool. Solenoid valves are widely used in industrial applications on electronically controlled machinery. The pilot operated solenoid valves are essentially two valves in one package. The solenoid is used to actuate a small pilot DCV, which in turn uses the pressure of the system to shift the main valve. This method of actuation is necessary on large valves that operate in systems at

high pressures. They are necessary because the solenoid alone cannot generate enough force to shift a large valve against a high pressure. The solenoid can, however, generate enough force to shift the small pilot valve, which can then use the pressure of the system to shift the main valve.

### **PRESSURE CONTROL VALVES**

The force of a cylinder is proportional to the pressure in a system and the area over which the pressure is applied. Controlling the pressure level in a circuit will therefore allow us to control the output force of a cylinder pressure control valves control the max pressure level and also protect the circuit from excessive pressure, which could damage components and possibly cause serious injury. Some types of pressure control valves simply react to pressure changes rather than control the pressure.

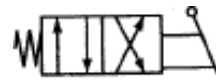

**Manual Lever**



**Pushbutton**



**Foot Pedal**



**Mechanical (Cam)**

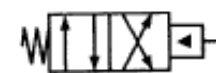

**Pilot Operated**



**Solenoid**

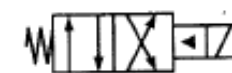

**Pilot Operated Solenoid**

**PRESSURE RELIEF VALVES**

Pressure relief valves limit the max pressure in a hydraulic circuit by providing an alternate path for fluid flow when the pressure reaches a preset level.

The basic types are

- 1 Direct acting pressure relief valve
- 2 Pilot operated pressure relief valve

## DIRECT ACTING PRESSURE RELIEF VALVES

All relief valves have a pressure port that is connected to the pump line and a tank port that is connected to the tank. The Figure shows the direct acting press relief valve, a ball or poppet is subjected to pump pressure on one side and the force of a spring on the other. When the pressure in the system creates a force on the ball that is less than the spring force, it remains on its seat and the pump flow will go to the systems as shown in Fig. A. When the pressure is high enough to create a force greater than the spring force, the ball will move off its seat and allow pump flow to go back to the tank through the relief as shown in Fig. B. The pressure at which the relief valve opens can be adjusted by changing the amount of spring compression, which changes the amount of force applied to the ball on the spring side.

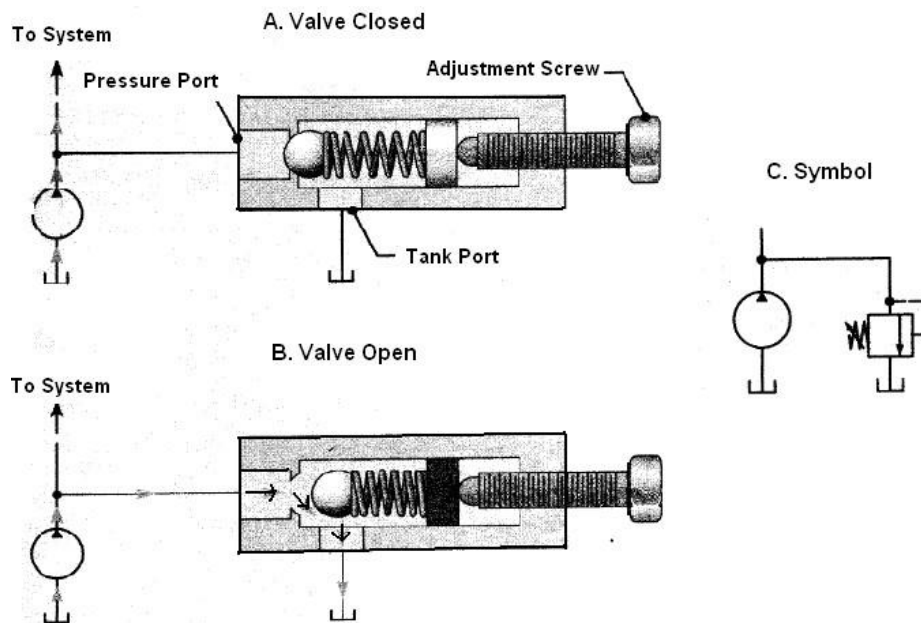

### Direct Acting Pressure Relief Valve

This is accomplished with an adjustment screw or knob. This type of relief valve is called direct acting because the ball is directly exposed to pump pressure. The graphic symbol for an adjustable pressure relief valve, along with a pump is shown in Fig. C. The symbol shows that the valve is normally closed on one side of the valve; pressure is fed in to try to open the valve, while on the other side the spring is trying to keep it closed. The arrow through the spring signifies that it is adjustable, allowing adjustment of the pressure level at which the relief valve opens.

## PILOT OPERATED PRESSURE RELIEF VALVE

The Figure A, B shows the pilot operated pressure relief valve, rather than a direct acting relief valve, is used to control the maximum pressure. A pilot operated relief valve consists of a small pilot relief valve and a main relief valve. It operates in a two stage process. First the pilot relief valve opens when a preset maximum pressure is reached, which then causes the main relief valve to open.

Just like the direct acting type, the pilot operated type has a pressure port that is connected into the pump line and a tank port that is connected to tank.

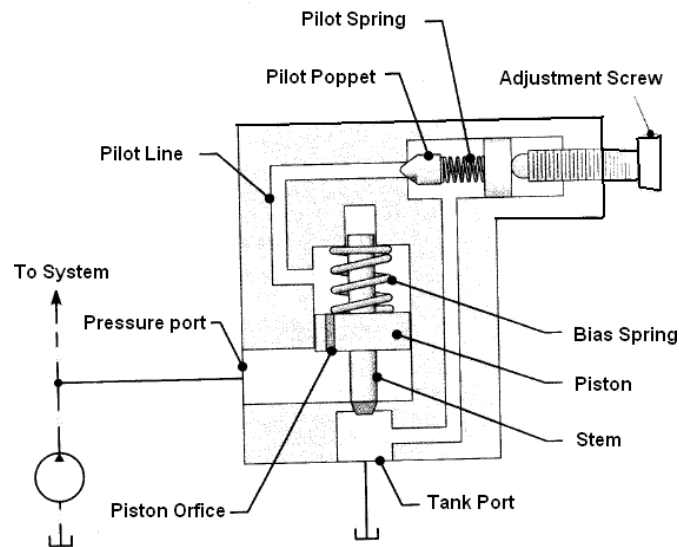

**A - Pilot Operated Pressure Relief Valve – Closed**

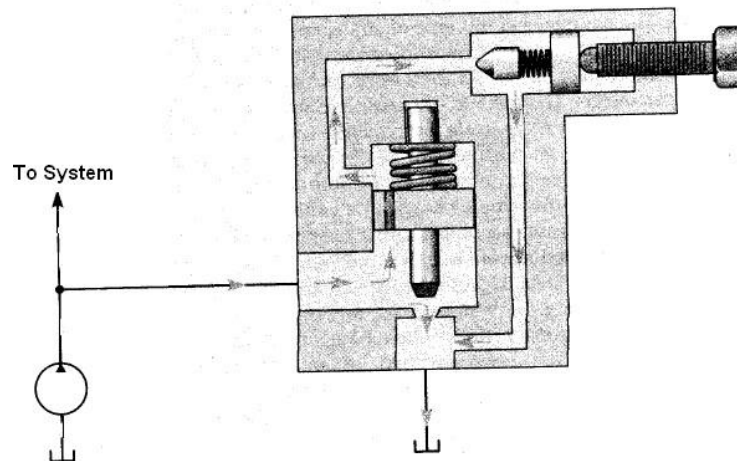

**B - Pilot Operated Pressure Relief Valve- Open**

The pilot relief is usually a poppet type. The main relief consists of a piston and stem. The main relief piston has a hole called the orifice drilled through it. This allows pressure to be applied to the top side of the piston, as well as the bottom side. The piston has equal areas exposed to pressure on the top and bottom and is therefore balanced it will have equal force on each side. It will remain stationary in the closed position. The piston has a light bias spring to ensure that it will stay closed.

When the pressure is less than the relief valve setting, the pump flow goes to the system. The pressure is also applied to the pilot poppet through the pilot line. If the pressure in the system becomes high enough, it will move the pilot poppet off its seat. A small amount of flow begins to go through the pilot line back to tank. Once flow begins through the piston orifice and pilot line, a pressure drop is induced across the piston due to the restriction of the piston orifice. This pressure drop then causes the piston

and stem to lift off its seat and the flow goes directly from the pressure port to the tank. The symbol for the pilot operated relief valve is the same as that used for the direct acting relief valve. The advantages are usually smaller than a direct acting type for the same flow and pressure ratings. They also generally have a wider range for the maximum pressure setting. Another advantage is that they can be operated remotely. This is achieved by connecting a direct acting relief valve to the vent port of the pilot operated relief valve as shown in Figure C. Notice that the vent port is connected into the pilot line. The direct acting relief valve, called the remote in this arrangement, acts as a second pilot relief valve. Flow can now go back to tank through either the onboard pilot or the remote pilot. Whichever pilot is set to a lower pressure will cause the relief valve to open. Flow through either pilot will cause the main poppet to lift off its seat and allow full flow back to the tank. The advantage of this type of arrangement is that the on board pilot can be set to the absolute

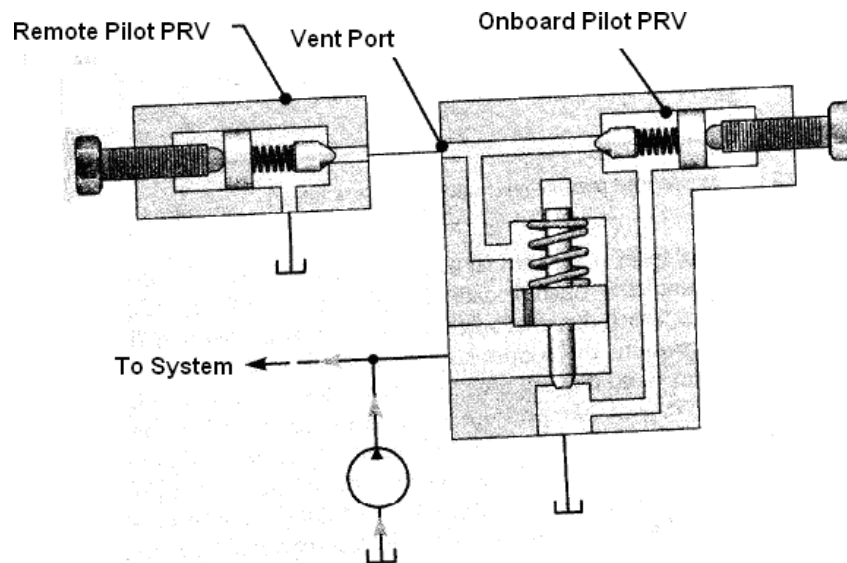

maximum pressure that the circuit is designed for, while the remote can be set for a lower

### C - Pilot Operated Pressure Relief Valve with Remote Control

pressure dictated by the current operating parameters. This method of pressure control has two key advantages

1. The on board pilot can be made in accessible so that if the machine operator were to inadvertently set the pressure of the remote too high, the pressure would never rise above the absolute maximum setting determined by the on board pilot.
2. The remote pilot can be located away from the circuit in a safe location that is easily accessible to the operator. In the symbol the lines associated with the remote are dashed because they are control pilot lines.

The pressure at which the relief valve begins to open is known as the cracking pressure. At this pressure, the poppet just begins to lift off its seat and some of the pump flow begins to go through

the relief valve back to the tank. The rest of the flow goes to the system. The pressure at which the relief valve is completely open is known as the full flow pressure. The difference between the cracking pressure and the full flow pressure is often called the pressure over ride in manufacture's literature.



## UNLOADING VALVES

In the case of pressure relief valve, the pump delivers full pump flow at the pressure relief valve setting and thus operates at maximum horse power conditions.

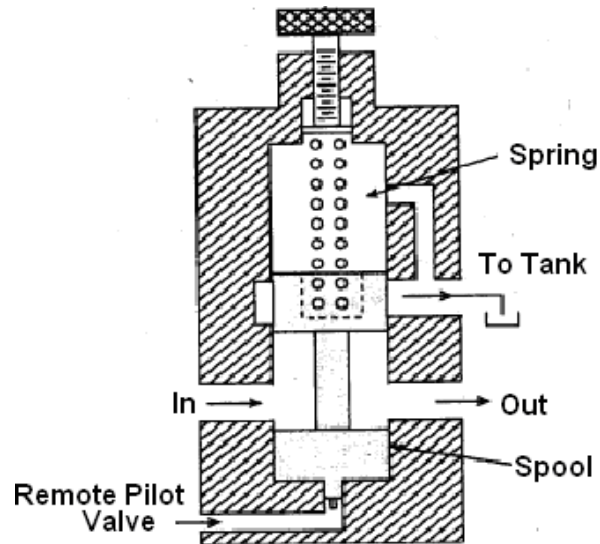

### Unloading Valve

The 'In' port of the unloading valve is connected to the line which is to be unloaded. The pilot port is connected to the line which is supposed to send the pressure impulse for unloading the valve. As soon as the system pressure reaches the setting pressure which is available at the pilot port, it lifts the spool against the spring force. The valve is held open by pilot pressure and the delivery from the pump starts going into the reservoir. When the pilot pressure is released, the spool is moved down by the spring and the flow is directed through the valve into the circuit. The unloading valve is useful to control the amount of flow at any given time in systems having more than one fixed delivery pump.

The symbol for each is shown in 'Figure A' for comparison. Both send flow back to the tank when a preset pressure is reached. However, an unloading valve reads the pressure in an external line, rather than in its own line, as indicated by the dashed pilot lines. 'Figure B' shows the application for an unloading valve. This circuit can be used in an application in which high flow (speed) and low

Pressure Relief Valve

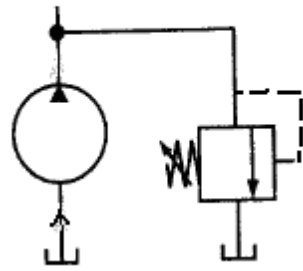

Unloading valve

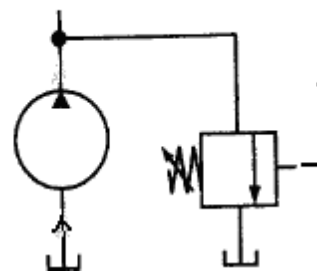

**A - Symbol Comparison**

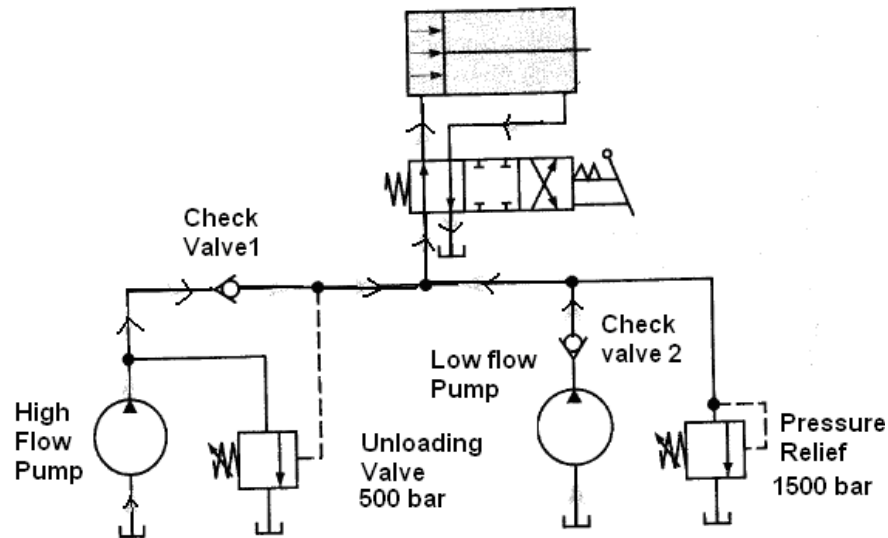

### B - Unloading Valve Circuit

pressure (force) is required for a part of the cylinder's stroke, while low flow and high pressure are required for the rest for example a metal stamping machine. In this machine it may be desirable for the cylinder to move into position very quickly, and then slow down when it reaches the work piece. The first part of the cycle requires only minimal pressure because the only resistance is the flow resistance of the components and the friction of the cylinder. The second part of the cycle requires high pressure because the cylinder is deforming the metal. This circuit supplies the cylinder with flow from both the high flow pump and the low flow pump when the pressure is below 500 bar. When the pressure reaches 500 bar, the unloading valve opens and unloads the high flow pump back to tank at low pressure. Only the low flow pump supplies the cylinder with flow at pressure from 500 bar to 1500 bar. If the pressure reaches 1500 bar, flow from the low flow pump is forced over the relief valve at this pressure. Check valve 1 isolates the high flow pump from the system pressure while it is being unloaded. Check valve 2 prevents the flow from the high flow pump from flowing into the low flow pump line. This would reverse the low flow pump, which would cause damage to the power unit.

### PRESSURE REDUCING VALVE

This type of valve is used to maintain reduced pressure in specified locations of hydraulic systems. It is normally an open valve. It is actuated by down stream pressure and tends to close as

this pressure reaches the valve setting. The figure shows the construction of the valve. This valve is one which uses a spring loaded spool to control the down stream pressure. If down stream pressure is below the valve pressure, fluid will flow freely from the inlet to the out let. When the outlet pressure increases the valve setting, the spool moves to partially block the outlet port. If the valve is closed completely by the spool, it could cause the down stream pressure to build above the valve setting. To avoid this, a drain line is provided to drain the fluid to the tank.

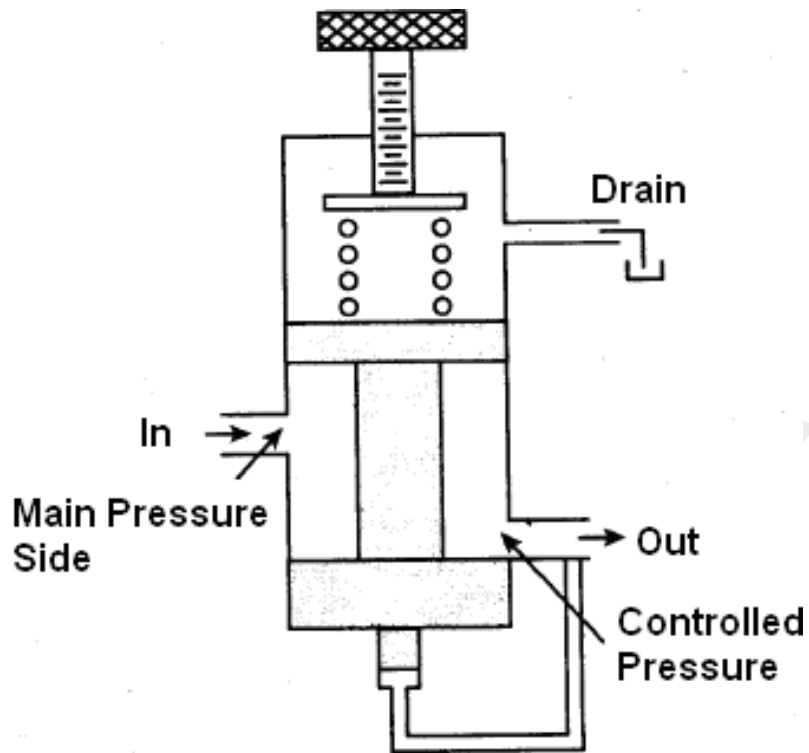

**Pressure Reducing Valve**

The below Figure compares the symbol for a relief valve and a reducing valve. The reducing valve is normally open, while relief valve is normally closed.

**Pressure Relief Valve**

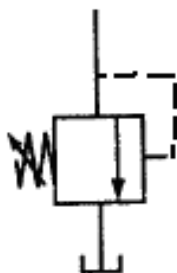

**Pressure reducing valve**

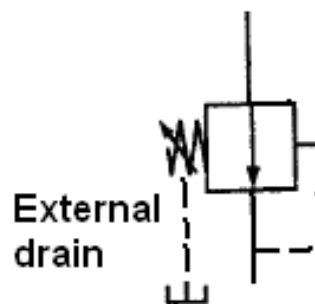

**Symbol Comparison**

The reducing valve reads the pressure down stream while the relief valve reads the pressure upstream. The reducing valve has an external drain line, while a relief valve does not. When a valve has an external drain, a line must be connected from the valves drain port to the tank. Drain lines, like pilot lines are shown as dashed lines.

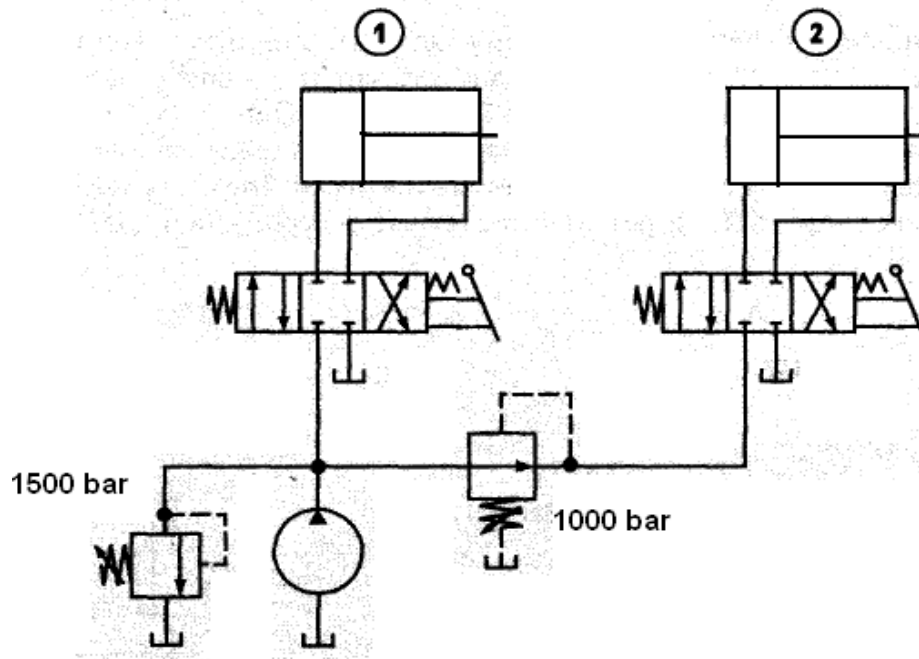

### Pressure Reducing Valve Application

The above figure shows an application for a pressure reducing valve. Here, two cylinders are connected in parallel. The circuit is designed to operate at a maximum pressure of 1500 bar, which is determined by the relief valve setting. This is the maximum pressure that cylinder will see. For a reason determined by the function of the machine, cylinder 2 is limited to a maximum pressure of 1000 bar. This is accomplished by placing a pressure reducing valve in the circuit in the location as shown.

If the pressure in the circuit rises above 1000 bar, the pressure reducing valve will close partially to create a pressure drop across the valve. The valve then maintains the pressure drop so that outlet pressure is not allowed to rise above 1000 bar setting. The disadvantage of this method of pressure control is that the pressure drop across the reducing valve represents lost energy that is converted to heat. If the pressure setting of the reducing valve is set very low relative to the pressure in the rest of the system, the pressure drop will be very high, resulting in excessive heating of the fluid. When the hydraulic fluid becomes too hot, its viscosity reduces, causing increased component wear.

### SEQUENCE VALVES

When the operation of two hydraulic cylinders is required to be performed in sequence by using a single direction valve, a special valve is required for this purpose and it is known as the sequence valve.



The sequence valve is to direct flow in a predetermined of sequence. The sequence valve operates on the principle that when system pressure over comes the spring setting, the valve spool moves up allowing flow to the secondary port that is connected with the second operating hydraulic cylinder.

The figure shows the symbol comparison of pressure relief valve and sequence valve.

Instead of sending flow back to the tank, however, a sequence valve allows flow to a branch circuit when a preset pressure is reached. The check valve allows the sequence valve to be by passed in the

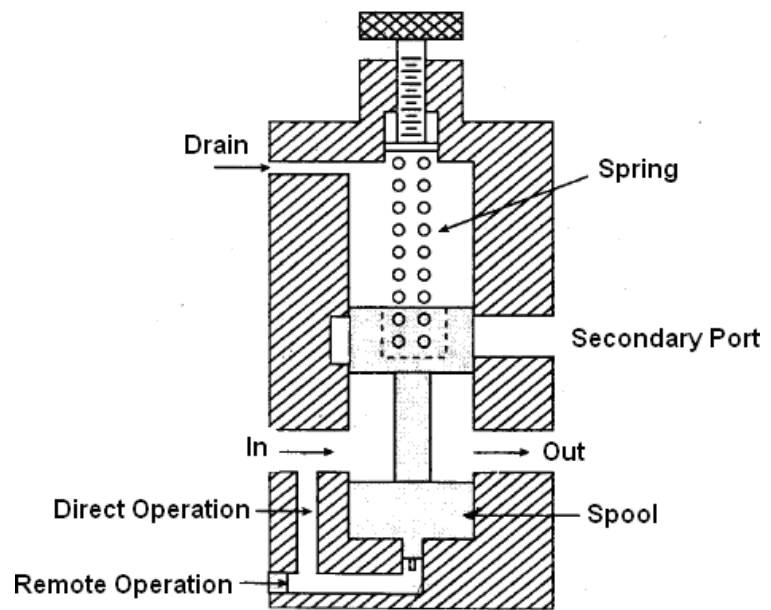

**Pressure Relief Valve**



**Sequence valve**

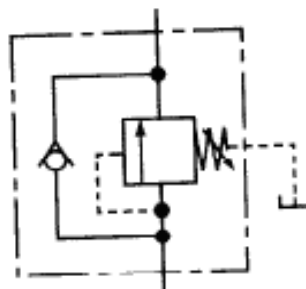

reverse direction. The component enclosure line indicates that the check is an integral part of the component. The sequence valve has an external drain line, therefore a line must be connected from the sequence valves drain port to the tank.

The below figure shows the circuit of tube bending machines uses sequence valve for clamping and bending tubes in sequence. As per the required sequence first the work piece has to be clamped, then bend to required shape, bending cylinder retract and clamping cylinder retract to unclamp the work piece. In this circuit, the bending cylinder will extend only after the clamp cylinder is fully extended and the clamp cylinder will retract only after the bending cylinder is fully retracted.

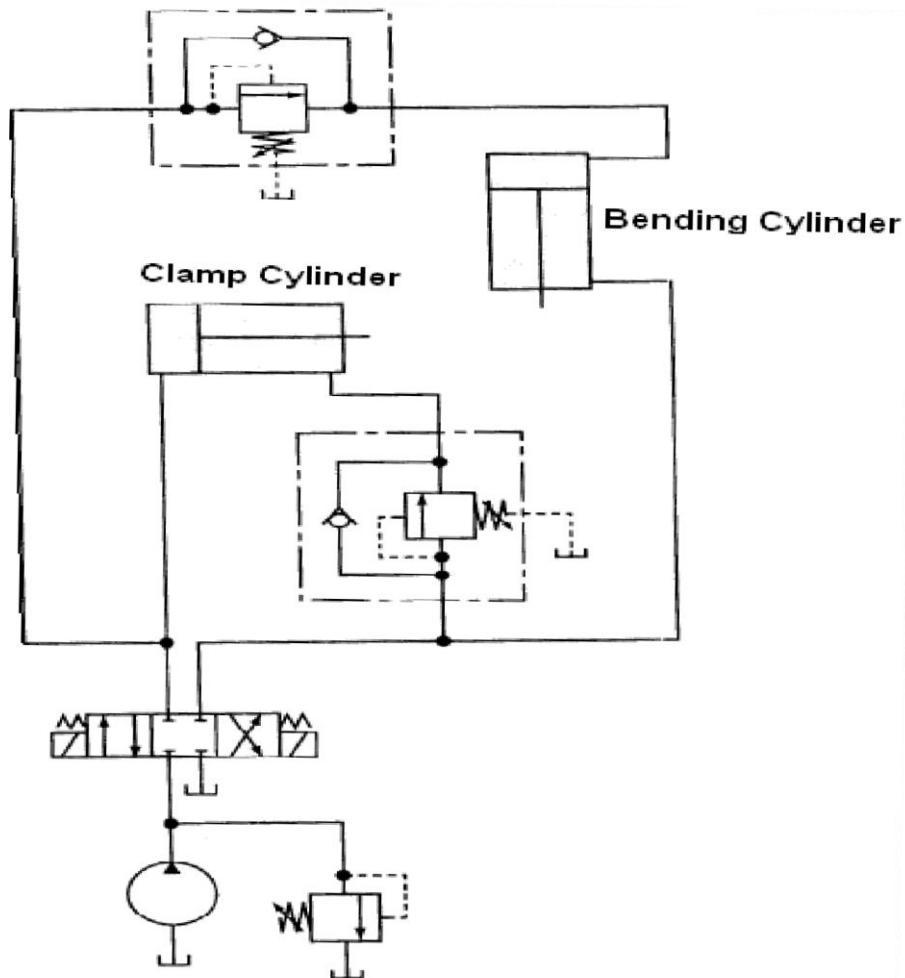

**Sequence Valve For Tube Bending Machine**

**COUNTER BALANCE VALVES**

A counter balance valve is used to maintain back pressure on a vertical cylinder to prevent it from falling due to gravity.

This valve operates on the principle that the line of flow from the bottom of the vertical cylinder into the valve remains closed till a pilot pressure is achieved. As soon as the pressure is developed, it over comes the spring force and the line of flow finds a free passage between primary port and secondary port. When the DCV is

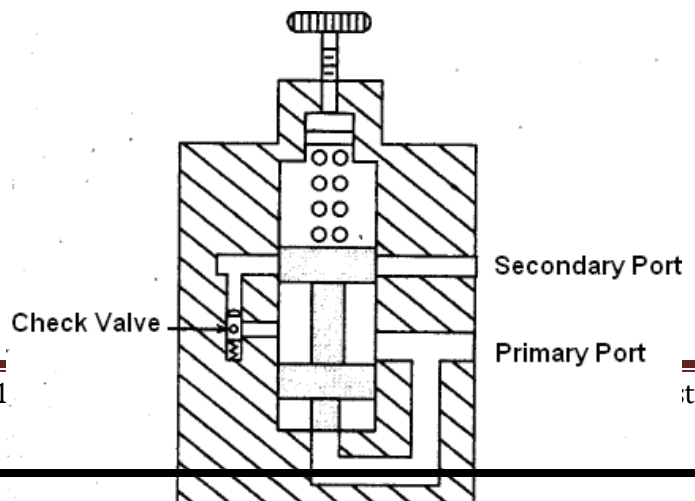

shifted to extend the cylinder, the weight may cause the cylinder to accelerate too quickly. When this occurs, the load is driving the cylinder, as apposed to the

more controllable situation of the cylinder driving load. This can cause damage to the load, or even to the cylinder itself, when the load is stopped quickly at the end of its travel. This can be remedied by placing a counter balance valve on the rod end of the cylinder as shown in below figure.

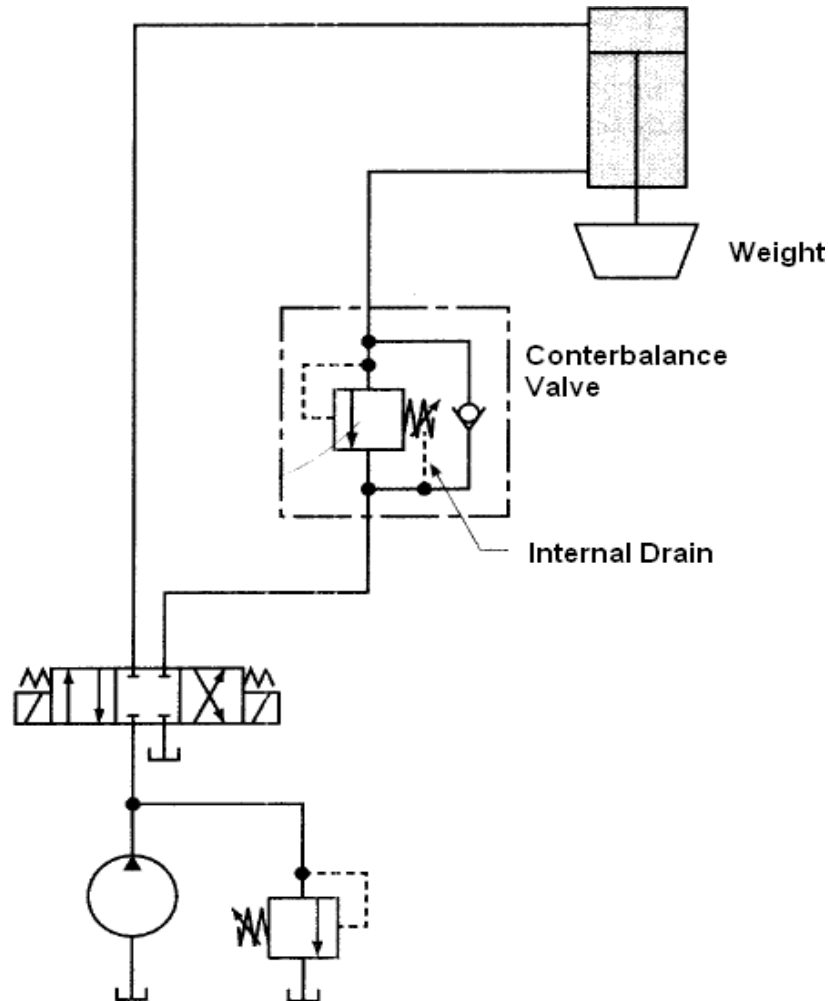

**Counterbalance Circuit**

When the DCV is shifted to lower the weight, the cylinder will not extend until a preset pressure is reached in the rod end. This provides a back pressure against the rod end of the piston, which acts to stabilize the downward movement of the cylinder. The check valve allows the counter balance valve to be passed when the cylinder is retracted. A counter balance valve has an internal drain, unlike the sequence valve, which has an external drain.

## **BRAKE VALVES**

Brake valves, like counter balance valves, are used to prevent loads from accelerating uncontrollably. Counter balance valves are used with cylinders, brake valves are used with hydraulic motors. Brake valves are most commonly used in circuits in which the motor must lower a large weight, such as in a winch application. A simple winch circuit is shown in Figure.

When the weight is lowered, it may tend to drive the motor, instead of the motor lowering the weight. This is known as an over running load. In this situation, the load will probably accelerate too quickly. The motor is being driven by the load and is basically acting as a pump. When this occurs, the

pressure at the outlet will be higher than the pressure at the inlet. The brake valve senses the pressure in both the inlet and outlet lines of the motor, just as it is with a pump.

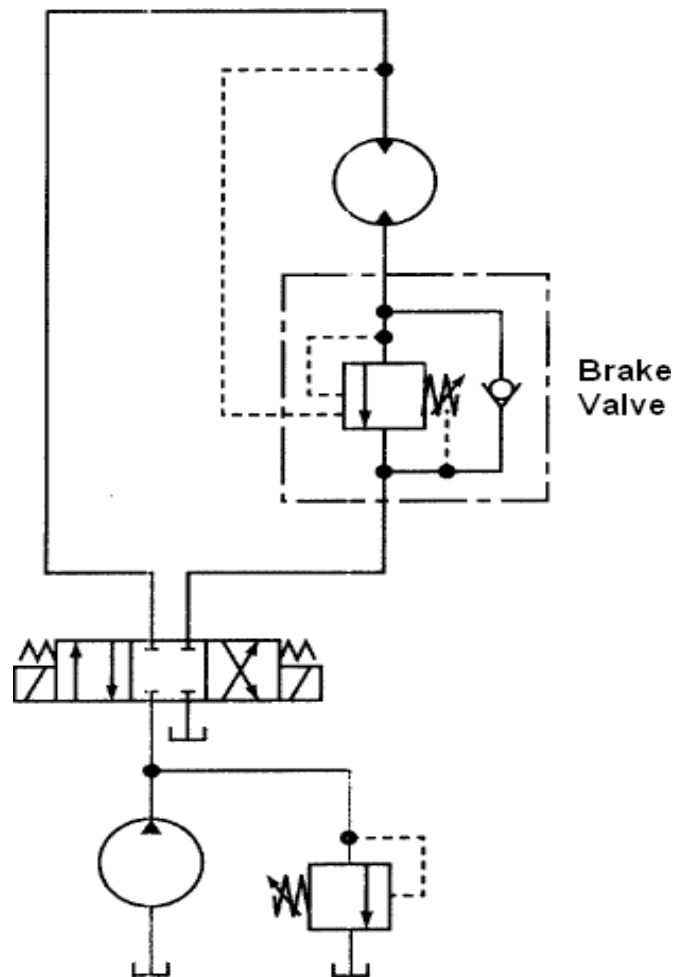

### Brake Valve In Winch Application

Whenever the pressure at the outlet is lower than the pressure at the inlet, the motor is functioning normally and the brake valve allows nearly unrestricted flow out of the motor. When the pressure at the outlet is higher than at the inlet, however, the brake valve closes partially to provide enough of a back pressure on the outlet of the motor to keep the load in control. The check valve allows the valve to be by passed when the weight is being raised.

### FLOW CONTROL VALVES

Flow control valves control the flow rate of fluid in a circuit. They accomplish this by incorporating a variable orifice into the circuit that acts like a faucet; closing the flow control valve orifice reduces the flow rate and opening the orifice increases the flow rate. The speed of an actuator depends directly upon the flow rate in the system. Controlling the flow rate therefore allows us to control the speed of actuators. A variable displacement pump's flow output can be

varied, even while it is being driven at a constant speed. This will also control the actuator's speed. In spite of this, flow control valves are commonly used because they are much less expensive and easier to control than variable pumps.

Types

1. Needle flow control valve
2. Pressure compensated flow control valve

## NEEDLE VALVE

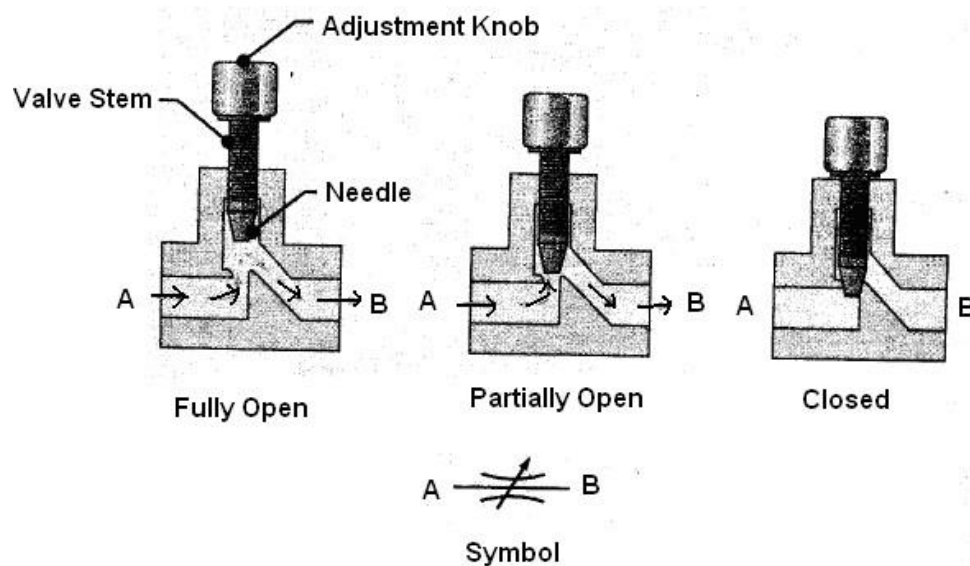

The simplest type of flow control valve is needle valve as shown in Figure.

### Needle Valve

This valve is basically just an adjustable orifice that can be closed to reduce the flow rate in a circuit. The orifice size is adjusted by turning the adjustment knob, which raises or lowers the valve stem and needle. The first figure shows the valve fully open, allowing nearly unrestricted flow. The valve is partially closed and is restricting the flow in the next figure. In the last figure, the valve is completely closed and is therefore allowing no flow. The symbol for a needle valve is shown in D. Needle valves are often used as manual shut-off in applications that require good metering characteristics. In most fluid applications, a needle valve with an integral check valve is used to control the flow rate as shown in below Figure. Part A shows the flow going through the valve from A to B. In this direction, it cannot go through the check and must therefore go through the restriction. In part B, the flow is coming from the opposite direction B to A and can pass through the check valve. The flow is virtually unrestricted in this direction. This flow control valve therefore only controls the flow rate from A to B. From B to A, the flow is uncontrolled because the restriction is bypassed through the check.



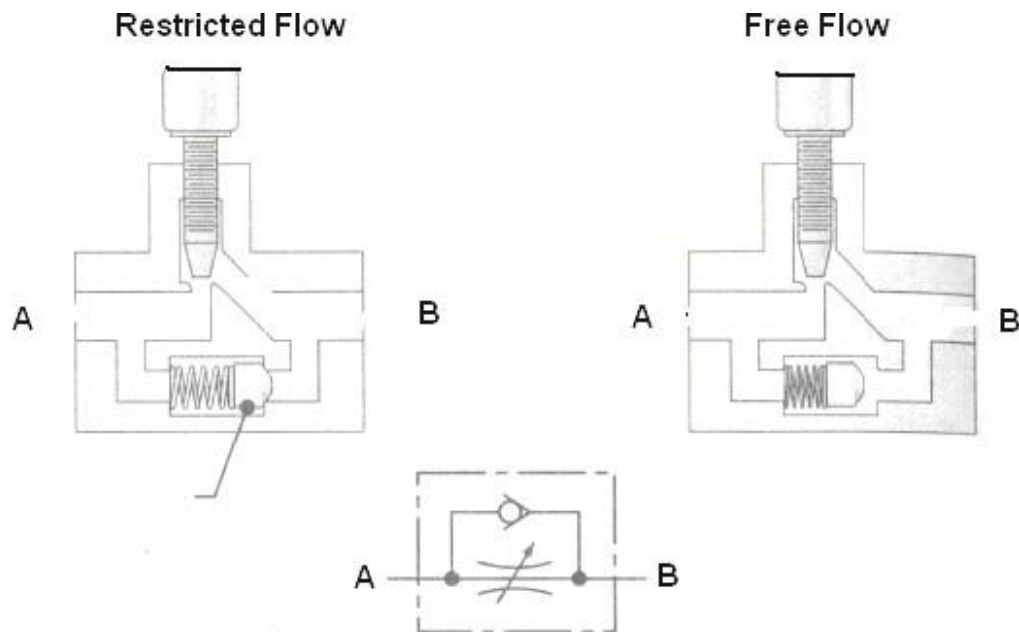

### Needle Valve with Integral Check Valve

#### PRESSURE COMPENSATED FLOW CONTROL VALVE

The flow control valves blocks the flow in term there is a pressure drop across the valve. This pressure drop affects the motion of the actuators and also increases the temperature of the fluid. To eliminate the above problems pressure compensated flow control valve is designed as shown in below Figure .

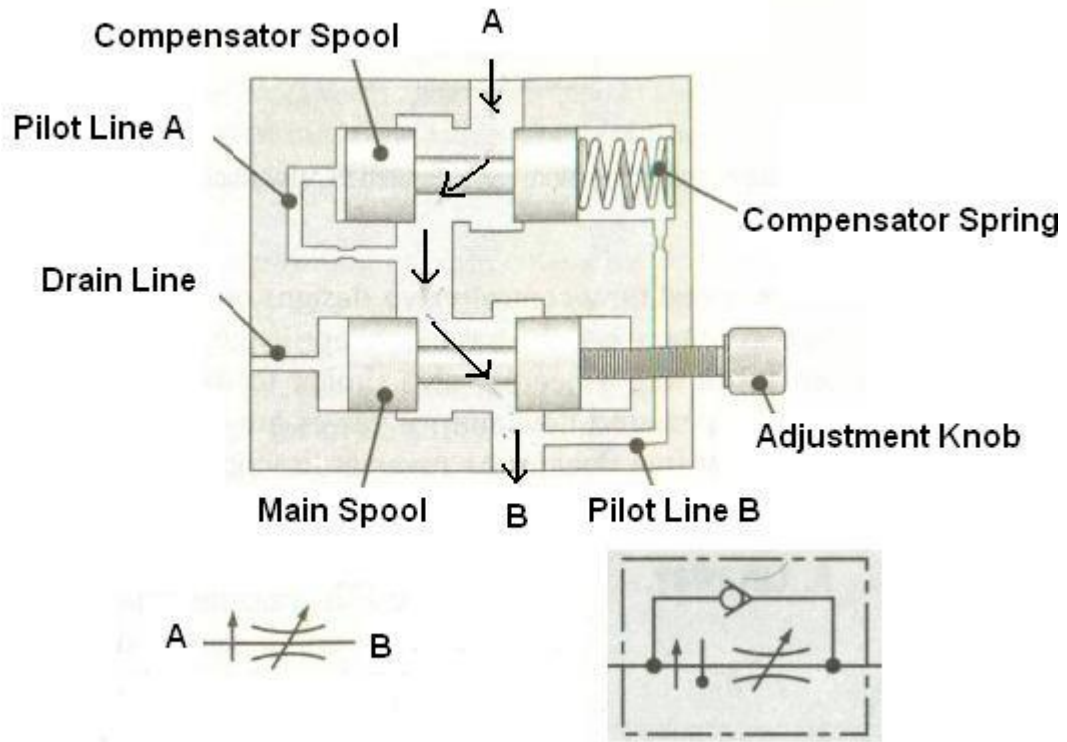

**Pressure Compensated Flow Control Valve**

This type of flow control valves automatically adjusts the size of the orifice in response to changes in system pressure. It accomplishes this through the use of a spring loaded compensator spool that reduces the size of the orifice when the upstream pressure increases relative to the downstream pressure. Once the valve is set, the pressure compensator will act to keep the pressure drop across the valve nearly constant. This in turn keeps the flow rate through the valve nearly constant. This valve consists primarily of a main spool and a compensator spool. The adjustment knob controls the main spool's position, which controls the orifice size at the outlet. The pressure upstream of (before) the main spool is ported to the left side of the compensator spool through pilot line A. Pressure downstream of (after) the main spool is ported to the right side of the compensator spool through pilot line B. The compensator spring biases the compensator spool to the fully open position. If the pressure upstream of the main spool increases too much relative to the downstream pressure (ie the pressure drop becomes too high), the compensator spool will move to the right against the force of the spring. This acts to keep the pressure drop across the main spool and consequently the flow rate nearly constant.

### **METER-IN FLOW CONTROL**

A cylinder with meter-in flow control of the extend stroke is shown is below Figure.

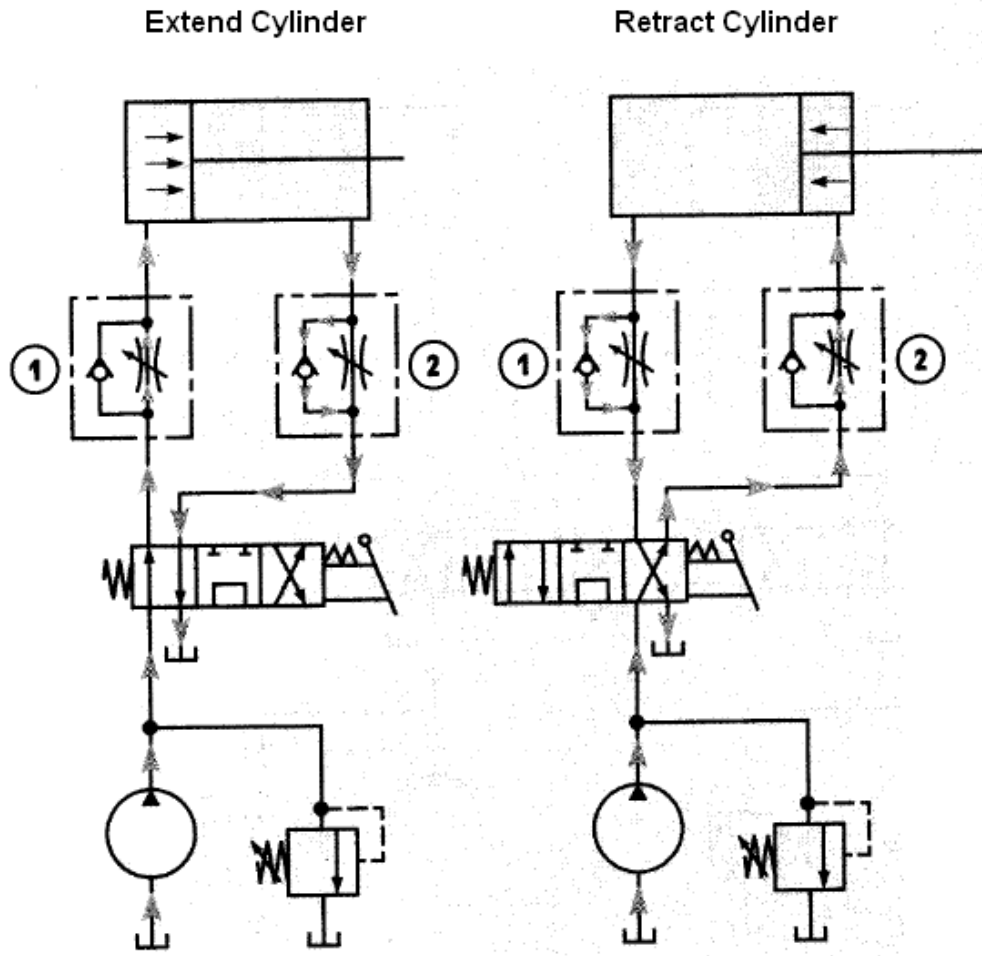

**Cylinders with Meter-In Flow Control**

When the cylinder is extending, the flow coming from the pump cannot pass through the check valve and is forced to go through the metering orifice (part A). When the cylinder is retracting, the needle valve is being by passed through the check (part B). The net result is that the flow control valve is controlling the extend speed, while the retract speed of the cylinder is uncontrolled. It is common to control only the working stroke of a cylinder, while allowing the return stroke move at full speed.

**METER-OUT FLOW CONTROL**

The Figure shows a cylinder with meter-out flow control of the extend stroke.

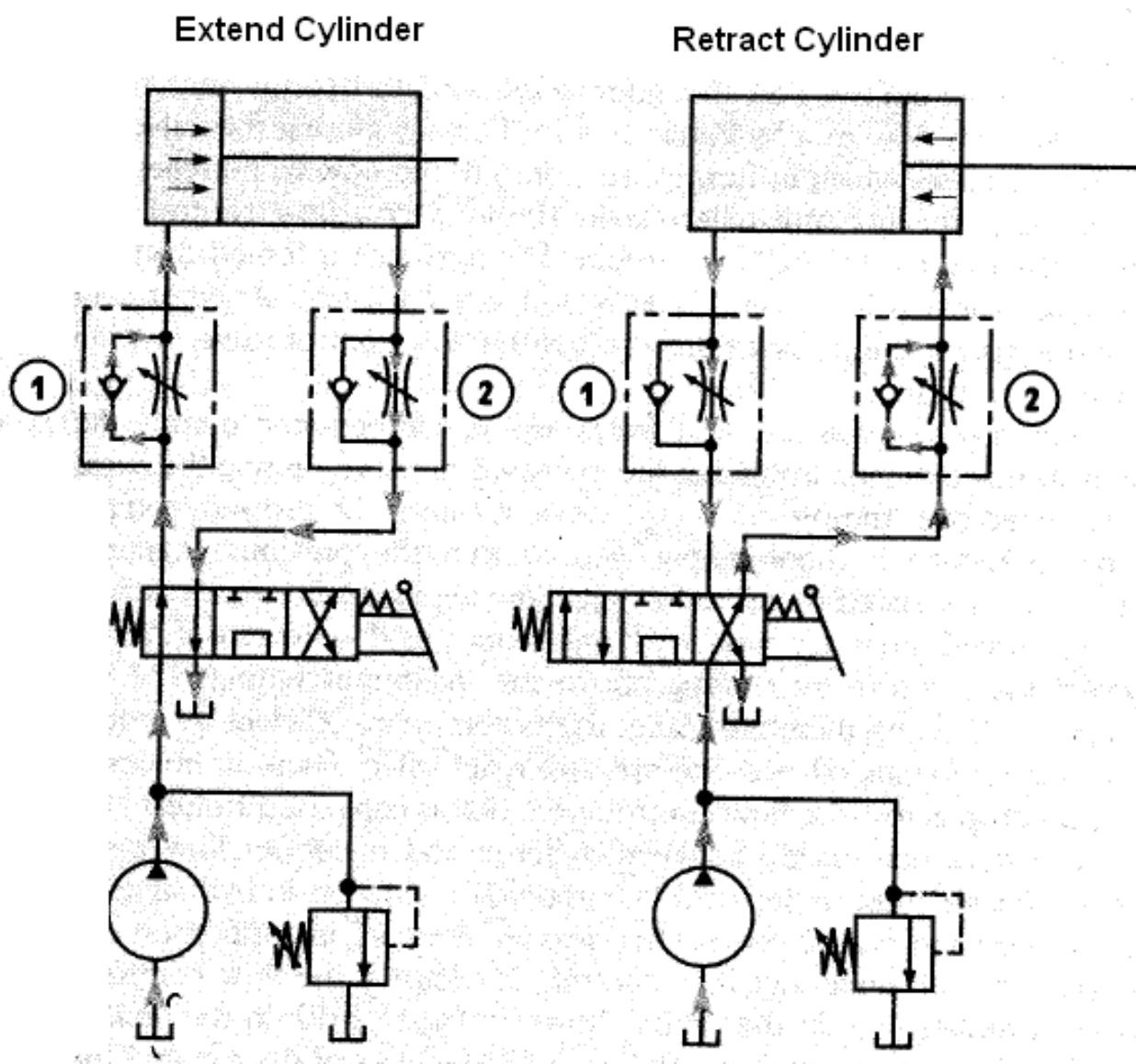

**Cylinders with Meter-Out Flow Control**

The flow control valve in this circuit is placed in the rod end line. When the cylinder is extending, the flow coming from the cylinder cannot pass through the check and is forced to go through the metering orifice (part A). When the cylinder is retracting, the metering orifice is being by passed through the check (part B). The net result is the same as with the previous circuit. The extend speed is controlled, while the retract speed is uncontrolled. However, in this circuit we control the flow rate act of the cylinder, while in the previous circuit we controlled the flow rate into the cylinder.

## BLEED-OFF CONTROL VALVE

In addition to meter-in and meter-out flow control, there is a less commonly used flow control configuration known as bleed-off.

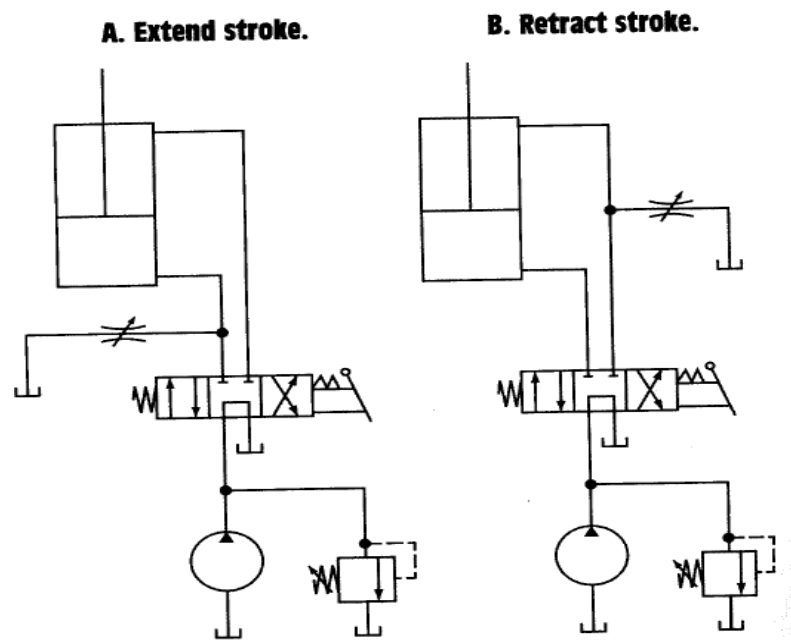

**Cylinders with Bleed- Off Control**

In this type of flow control, an additional line is run through a flow control back to the tank. To slow down the actuator, some of the flow is bled off through this line, thereby reducing the flow to the actuator. Figure A' shows bleed off control of the extend stroke, 'Figure B' shows control of the retract stroke. Note that the operation of a bleed-off flow control valve is opposite to a meter-in or meter-out flow control valve. Opening a bleed-off flow control valve slows down an actuator, while opening a meter-in or meter-out flow control valve increases actuator speed.

## FLOW DIVIDER

Flow dividers divide the flow from a pump into two or more streams of equal flow rates. They maintain equal flow rates in the branch circuits even if the pressures in the branches are not equal. Without flow divider, the flow from the pump would follow the path of least resistance.

There are two commonly used flow divider designs balanced spool and rotary. The Figure shows a simplified cut away of a balanced spool flow divider. The spool is free to slide back and forth in the housing and will naturally assume a position so that the pressure on either side of the spool will be equal. The spool is therefore pressure balanced. For example if the pressure at outlet 1 was greater than the pressure at outlet 2, the spool would slide to the right to partially

cover outlet 2. By partially restricting the more lightly loaded outlet, the flow divider adds more resistance to this path. This acts to equalize the resistance of each path.



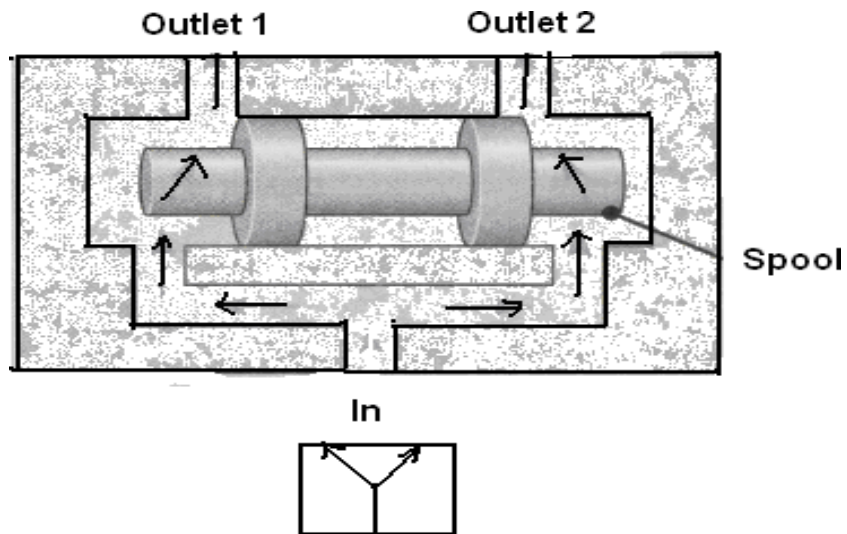

**Balanced Spool Flow Divider**

**Outlet 1      Outlet 2**

The rotary flow divider is basically two gear pumps are in one housing whose inlets are joined together as shown in Figure.

Their shafts are also coupled together so that they must turn at the same speed. Because they are forced to turn at the same speed, they will supply equal flow to their outlets when placed in a pump line.

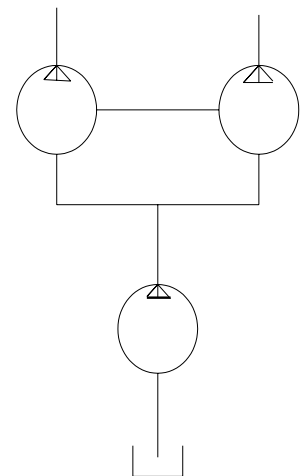

## ACCUMULATORS

Accumulators are devices that store hydraulic fluid under pressure. Storing hydraulic fluid under pressure is a way of storing energy for later use. Perhaps the most common application for an accumulator is supplementing the pump flow in a hydraulic system in which a high flow rate is required for a brief period of time.

Types;

1. Weight loaded accumulator
2. Spring loaded accumulator
3. Gas charged accumulator
4. Piston type
5. Bladder type
6. Diaphragm type

### **WEIGHT LOADED ACCUMULATOR**

It is basically a vertically mounted cylinder with a large weight as show in Figure.

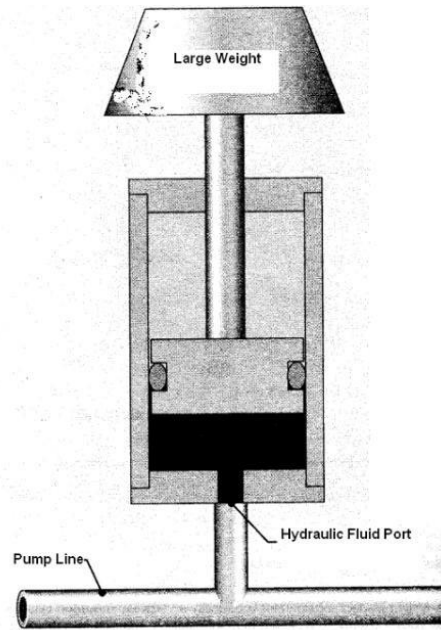

### **Weight Loaded Accumulator**

When hydraulic fluid is pumped into this accumulator, the weight is raised. The weight then applies a force to the piston, which generates a pressure on the fluid side of the piston. The advantage of this type of accumulator over all of the other, it applies a constant pressure on the fluid throughout its entire range of motion. The disadvantage is that a very large weight must be used to generate enough pressure. Because of that this type is seldom used.

### **SPRING LOADED ACCUMULATOR**

A spring loaded accumulator stores energy in the form of a compressed spring as shown in

figure.

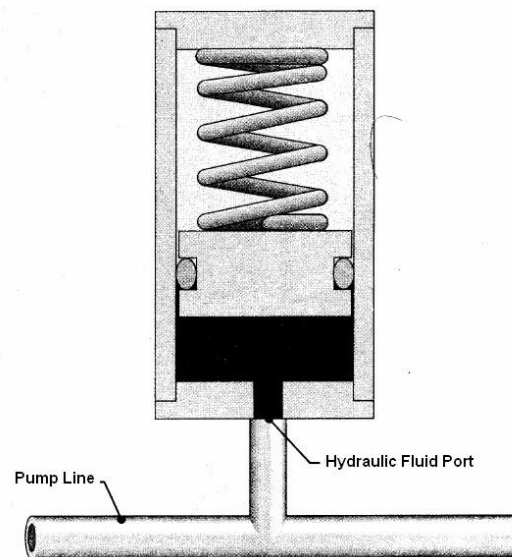

### Spring Loaded Accumulator

Hydraulic fluid is pumped into the accumulator, causing the piston to move up and compress the spring. The spring then applies a force on the piston that exerts a pressure on the hydraulic fluid. The

pressure is constantly decreasing as hydraulic fluid is drawn out because the spring decompresses and therefore exerts less force on the piston. This type is not commonly used in hydraulic circuit because a large spring must be used to generate enough pressure.

### PISTON TYPE ACCUMULATOR

The basic construction of a piston type, gas charged accumulator is shown in Figure.

Its operation begins when the gas chamber is filled with a gas to some predetermined pressure called the pre-charge, which causes the free-sliding piston to move down. Once the accumulator is pre- charged, hydraulic fluid can be pumped into the hydraulic fluid port.

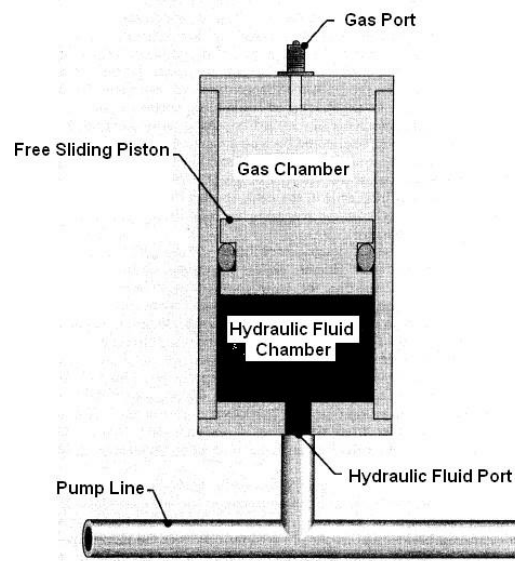

As the hydraulic fluid enters the accumulator, it causes the piston to slide up, thereby compressing the gas. Compressing the gas increases its pressure, and this pressure is then applied to the hydraulic fluid through the piston. Because the piston is free sliding, the pressure on the gas and the hydraulic fluid is always equal. Whenever the pressure in the system drops below the pressure in the accumulator, fluid will flow out of the accumulator and into the system. As the hydraulic fluid flows out of the accumulator, the gas decompresses and loses pressure, which in turn causes the pressure on the hydraulic fluid to be reduced. The gas used to pre-charge accumulator is usually nitrogen because it is an inert gas and does not support combustion.

### BLADDER TYPE ACCUMULATOR

The basic construction of a bladder type accumulator is shown in Figure. These accumulator functions in the same way as a piston accumulator, storing energy in the form of

a compressed gas. However, instead of the gas and hydraulic fluid being separated by a piston, they are separated by a synthetic rubber bladder. The bladder is filled with nitrogen until the desired pre-charge pressure is achieved. Hydraulic fluid is then pumped into the accumulator, thereby compressing the gas and increasing the pressure in the accumulator, just as with the piston type. The

port cover is a small piece of metal that protects the bladder from damage as it expands and contacts the hydraulic fluid port.

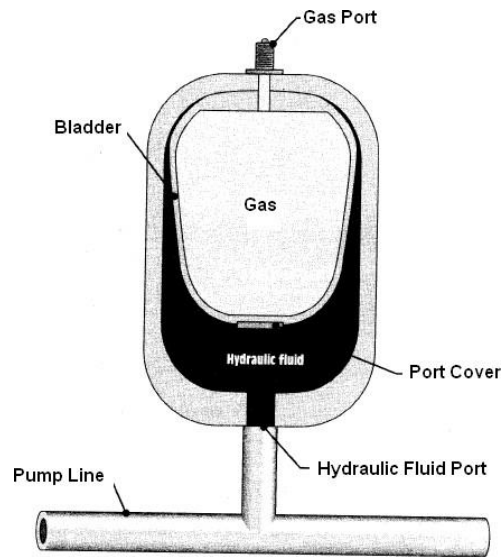

### Bladder Type Accumulators

### DIAPHRAGM ACCUMULATOR

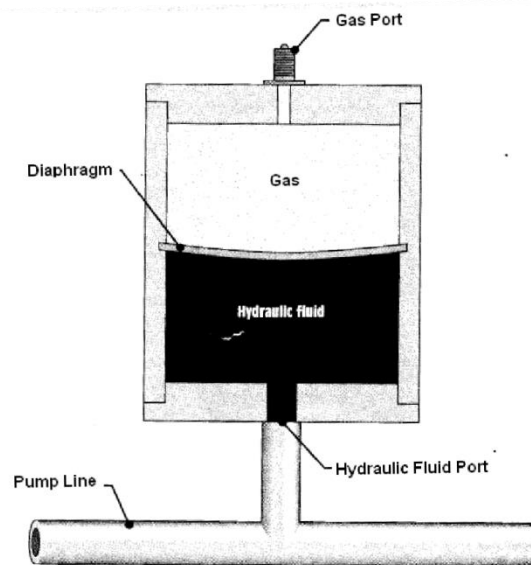

### Diaphragm Accumulators

The vessel is separated into two components by a flexible diaphragm. One compartment is

connected to the hydraulic system and the other to the high pressure gas system. Thus the diaphragm serves as an elastic barrier between the oil and the gas. When the oil is delivered into the accumulator, it deforms the diaphragm. The gas is compressed when the charged oil pushes the diaphragm against it. This gas pressure is used as the potential energy to force the oil out when it is required in the circuit. The advantage of bladder and diaphragm accumulators over the piston type is that they have no sliding surface that requires lubrication and can therefore be used with fluids with poor lubricating



qualities. They are also less sensitive to contamination due to lack of any close fitting sliding components.

### **NON-SEPARATED TYPE ACCUMULATOR**

It consists of a fully enclosed shell containing a gas charging valve on the top and an oil port on the bottom. The confines at the top and oil remain at the bottom and there is no physical separator between them. Since the gas has direct contact with the oil, this type is termed as non separator type accumulator. Due to the absence of separator, the gas is absorbed and also entrapped in the oil. This accumulator type is not preferred for use with high speed pumps because the entrapped gas in the oil may cause cavitations and damage to the pump. The problems of aeration of the oil often limit their use in hydraulic system.

### **APPLICATIONS OF ACCUMULATORS**

Accumulators are used as

1. Leakage compensator
2. Auxiliary power source
3. Emergency power source
4. Hydraulic shock absorber
5. Fluid make-up device

### **ACCUMULATOR AS LEAKAGE COMPENSATOR**

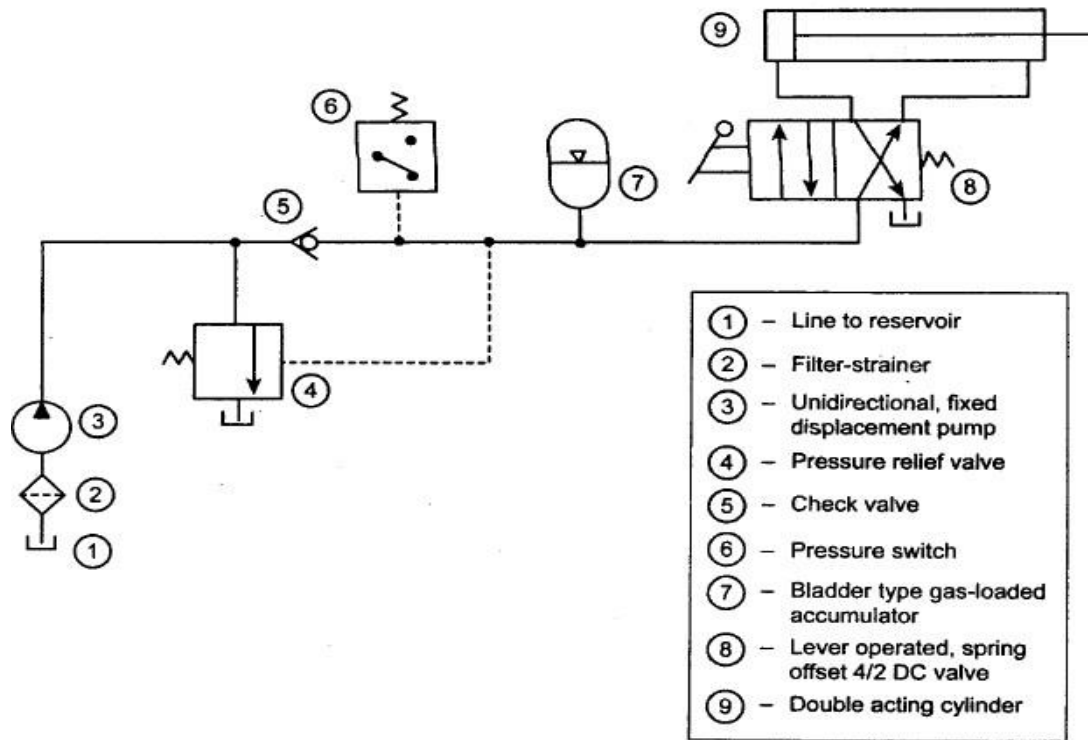

The stored energy of the accumulator can be used to compensate any possible loss of energy due to internal or external leakage in a system. This application is extremely helpful in circuits, such as are used for hydraulic presses, which require high pressure for long periods. First operator places

work piece on the press and shifts handle of the 4/2 DC valve. Now the oil flows to blank end of cylinder and piston extends. The pressure builds up and oil fills the accumulator. When maximum pressure is reached, the pressure switch stops the pump motor. In these applications, the cylinder and piston arrangement is required to press the work piece for a longer period of time. During this period, the internal and external leakage may reduce the cylinder pressure. The leakage oil is replaced with the oil from the accumulator. This leakage replacement of oil is carried for a longer period of time. The maximum length of time is determined by the volume of the accumulator and the rate of leakage in the cylinder. When the pressing cycle has been completed, the operator shifts the handle of the 4/2 DC valve to original position. Thus a cycle is completed.

### **ACCUMULATOR AS AUXILIARY POWER SOURCE**

As we know, the electric motor or pump motor is a primary power source. In this application, the accumulator stores the oil during one portion of the work cycle and releases the oil during the remaining cycle. Thus accumulator serves as a secondary power source. Figure shows the circuit using accumulator as a secondary power source. After placing the work piece on slide table and shifts handle of 4/2 DC valve. Now oil flows from the accumulator to blank end of slide cylinder. This extends the piston until slide table reaches end of stroke. When the cylinder is in the fully extended position, the accumulator is charged with the oil by the pump. Then the operator shifts the handle of 4/2 DC valve for the retraction of the cylinder. Now the oil flows from the pump as well as from the accumulator to retract the cylinder quickly.

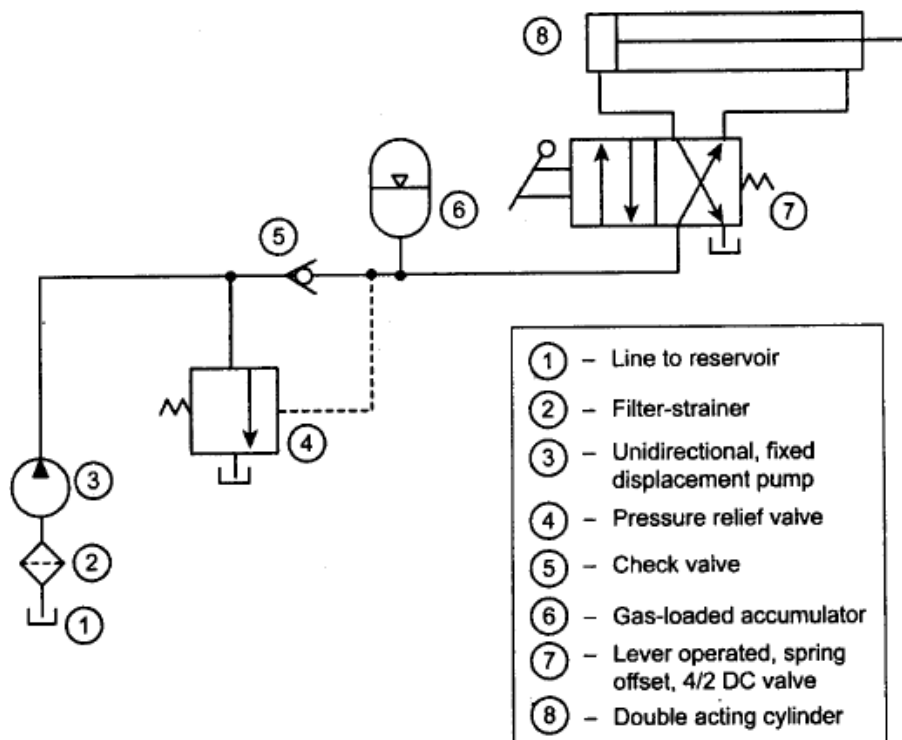

### ACCUMULATOR AS EMERGENCY POWER SOURCE

In some hydraulic applications, it is necessary to retract the pistons of cylinder to their starting position; even there may be an electrical power failure. In such applications, the accumulator can be used as an emergency power source to retract the piston of the cylinder.

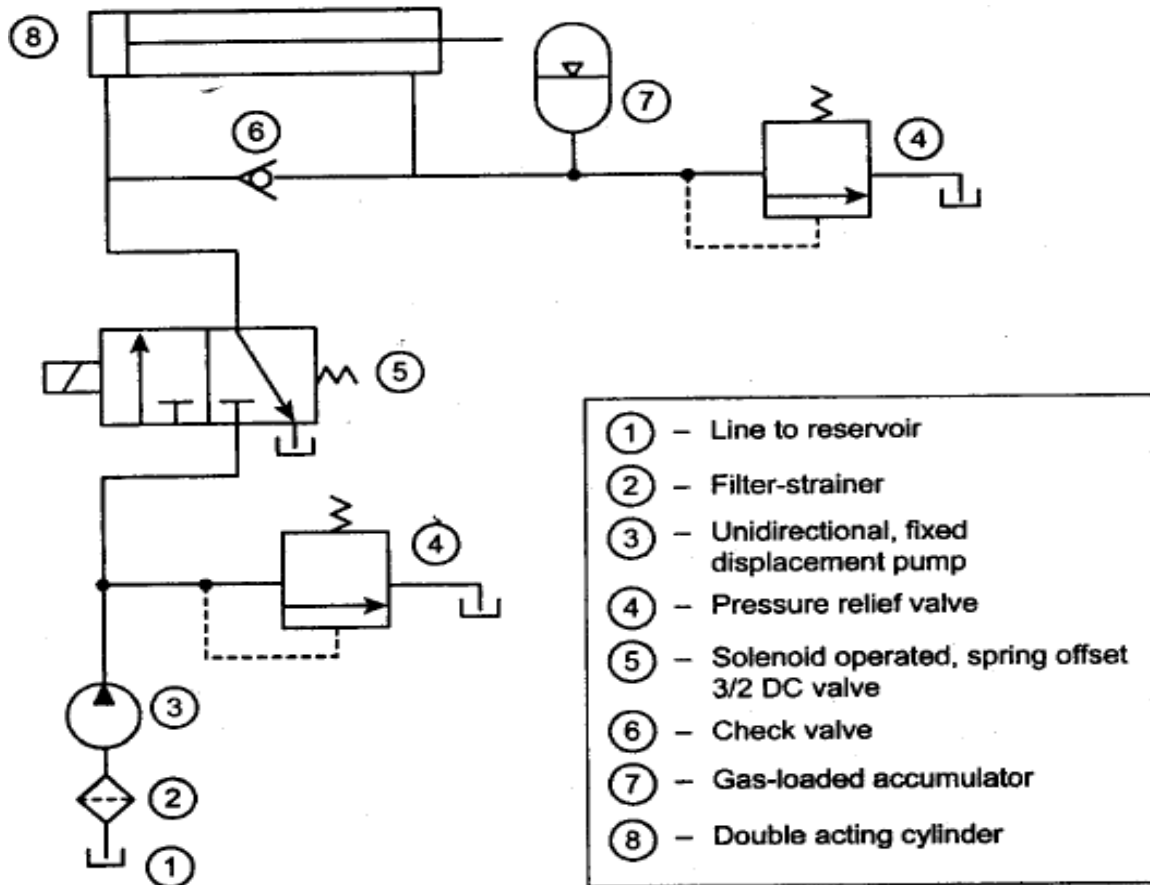

### Accumulators as Emergency Power Source

When operator depresses push button energizing solenoid of the 3/2 DCV, oil flows to blank end of cylinder. At the same time, the oil also unseats check valve. So the oil under pressure flow to rod end of cylinder and into the accumulator. When there is a power failure, the solenoid will de-energize. In the absence of solenoid energy, the spring pressure forces the valve to shift to its spring offset mode. Now the oil stored under pressure is forced from the accumulator to the rod end of the cylinder. Thus the piston of the cylinder retracts to the starting position.

### ACCUMULATOR AS HYDRAULIC SHOCK ABSORBER

In many high pressure hydraulic systems, the sudden stoppage of a hydraulic fluid flowing

at high velocity in pipelines can cause considerable damage to the piping. This hydraulic shock, also known as water hammer, may snap heavy pipes, loosen fittings and cause leaks. By installing an accumulator, this high pressure pulsations or hydraulic shocks can be absorbed. Figure shows the circuit employing accumulator for serving as a hydraulic shock absorber.

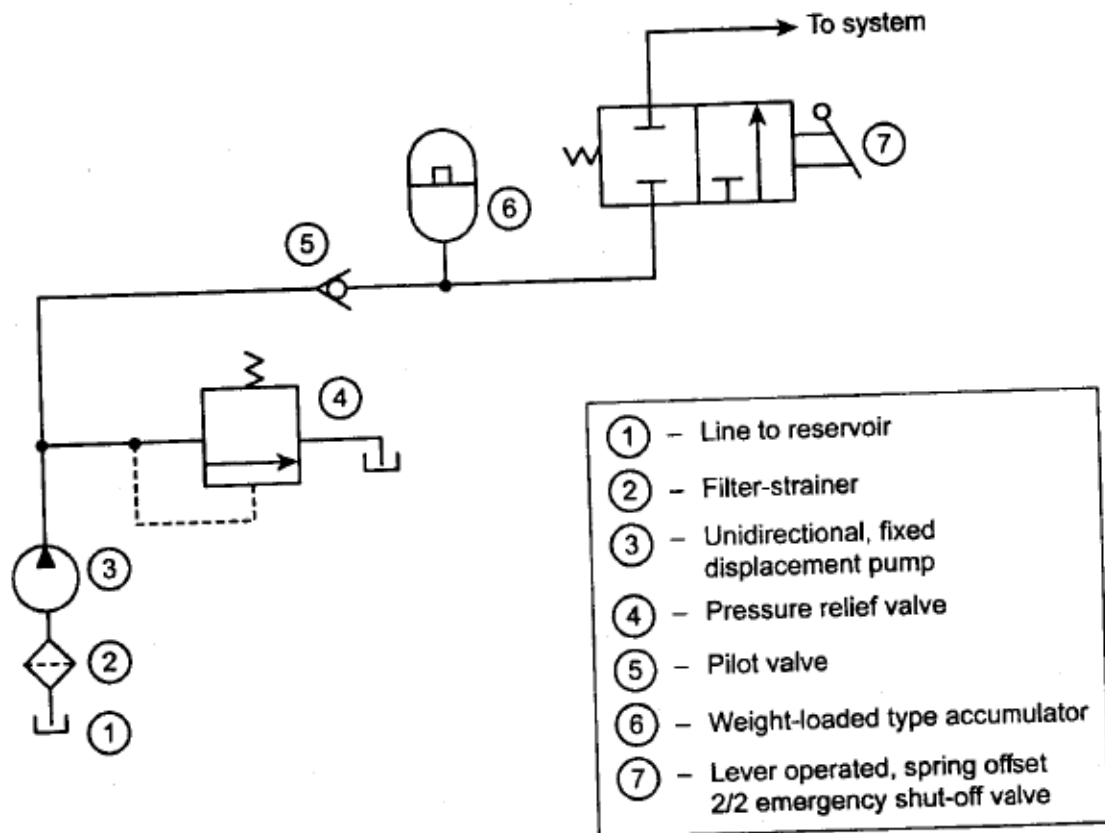

### Accumulators as a Hydraulic Shock Absorber

The accumulator installed near the shut-off point in order to be more effective in quickly absorbing the shock wave. When the system demands to shut-off the supply suddenly, a 2/2 shut-off valve is used for the purpose. When operator shifts handle of the 2/2 emergency shut-off valve, the fluid flow is stopped suddenly. This results in high-pressure pulsations or hydraulic shock. The pressure pulsation is blocked by check valve. The surges between the check valve and the shut-off valve are used to store the oil in accumulator and thus the pressure pulsations of the oil in the pipe line are absorbed.

### INTENSIFIER

Pressure intensifier or boosters are devices used to generate pressure greater than

those achievable with standard hydraulic pumps alone. They take the inlet flow from the pump and intensify the pressure. A simplified cut way of an intensifier is shown in Figure.



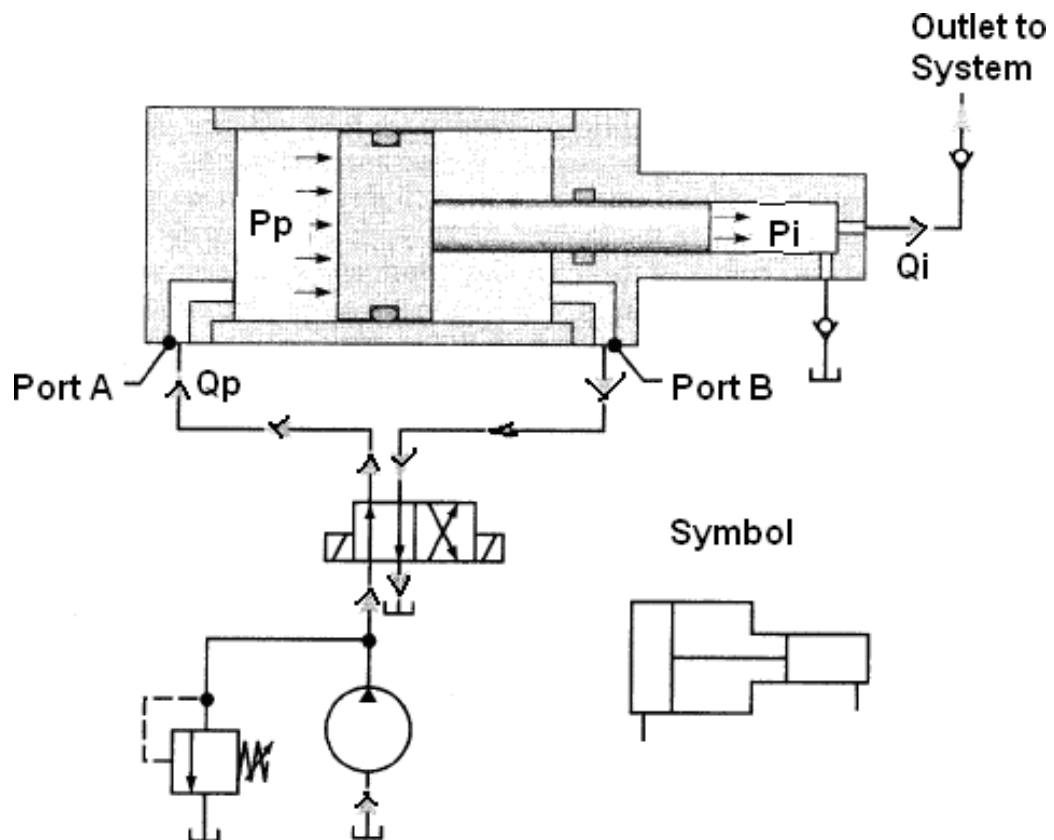

### Single Acting Intensifiers

The intensifier is shown on the forward stroke. In this situation, the pump flow ( $Q_{\text{pump}}$ ) is fed into port A of the intensifier, which applies a pressure ( $P_{\text{pump}}$ ) to the piston, causing it to move right. This in turn generates a force that is applied to the rod. The force on the rod then creates pressure and flow at the outlet to the system. When the four way directional control valve is shifted to the opposite position, the pump flow is sent to port B of the intensifier, causing the piston to move left. This causes fluid to be drawn into the rod chamber which completes one cycle. The Figure shows the usage of intensifier in the punching machine. After placing the work piece in the fixture and shifts handle of 4/2 DCV to the right side, the oil flows to the blank end of the cylinder through the check valve. When the pressure in the cylinder reaches the sequence valve pressure setting, the sequence valve opens and supplies the flow to the intensifier. Now the intensifier starts to operate and gives high pressure output. This high pressure output of the

intensifier closes the pilot check valve and pressurizes the blank end of the cylinder to perform the punching operation.

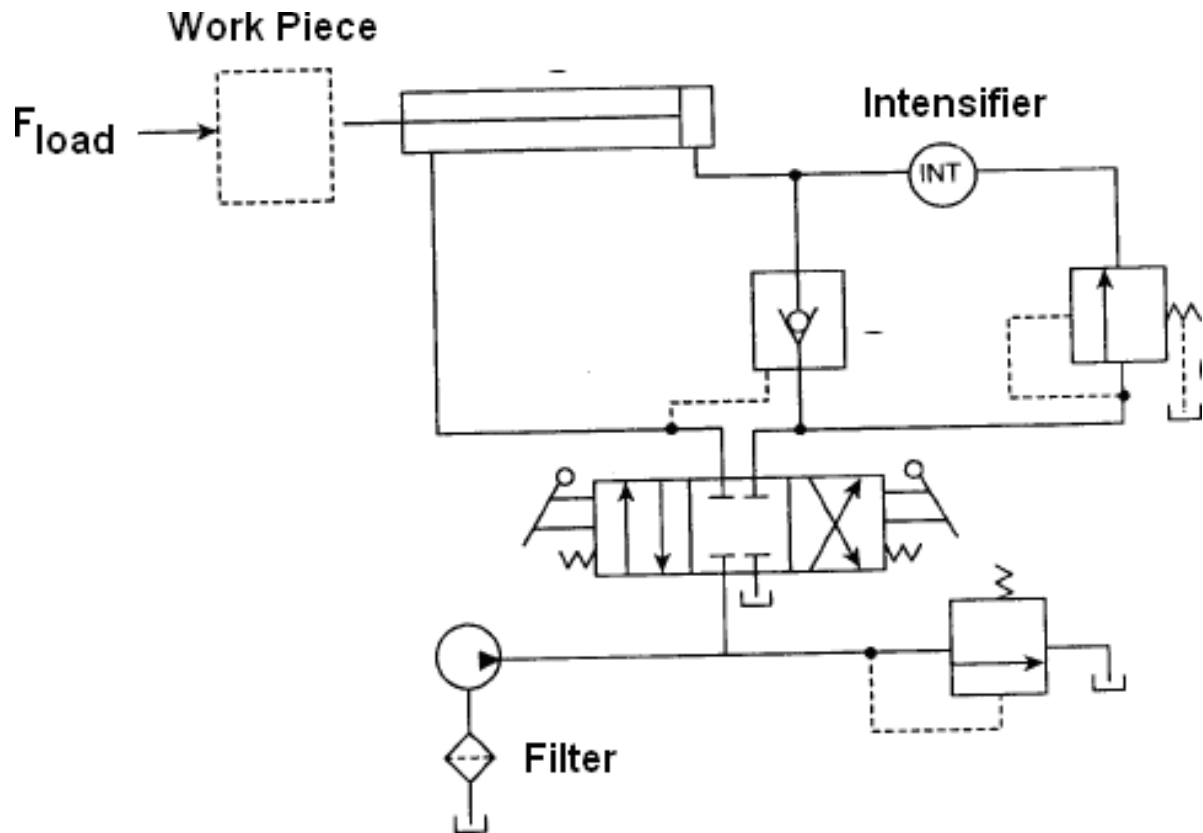

### Pressure Intensifier Circuit

When the 4/2 DCV is shifted to the left side position, the oil flows to the rod end of the cylinder. When it builds-up the pressure, the pilot signal opens the check valve. Thus the cylinder is retracted to the starting position.

### AIR-OVER-OIL INTENSIFIER CIRCUIT

In some applications, the hydraulics and pneumatics circuits are coupled to best use of the advantage of both oil and air mediums. This combination circuit is also known as hydro-pneumatic or dual pressure systems. Figure shows a typical air-over-oil intensifier. This circuit can be used for drawing a cylinder over a large distance at a low pressure and then over a small distance at high pressure. This circuit consists of two lines- air lines and oil lines. In the circuit the air lines are shown by single lines and oil lines by double lines. When the first 4/2 DCV valve1 is shifted to left mode, the air from the reservoir flows to the approach tank. In the approach tank, the air forces the

oil to the blind end of the cylinder through the bottom of the intensifier, as shown by double lines. Now the cylinder extends. When the cylinder experiences its load, the second 4/2 valve<sup>2</sup> is actuated to the left mode. This valve position sends air to the top end of the intensifier. Now the intensifier moves down, and the piston of the intensifier blocks the path of oil from the approach tank. Now the cylinder receives high pressure oil at the blind end to perform the useful work such as punching operation.

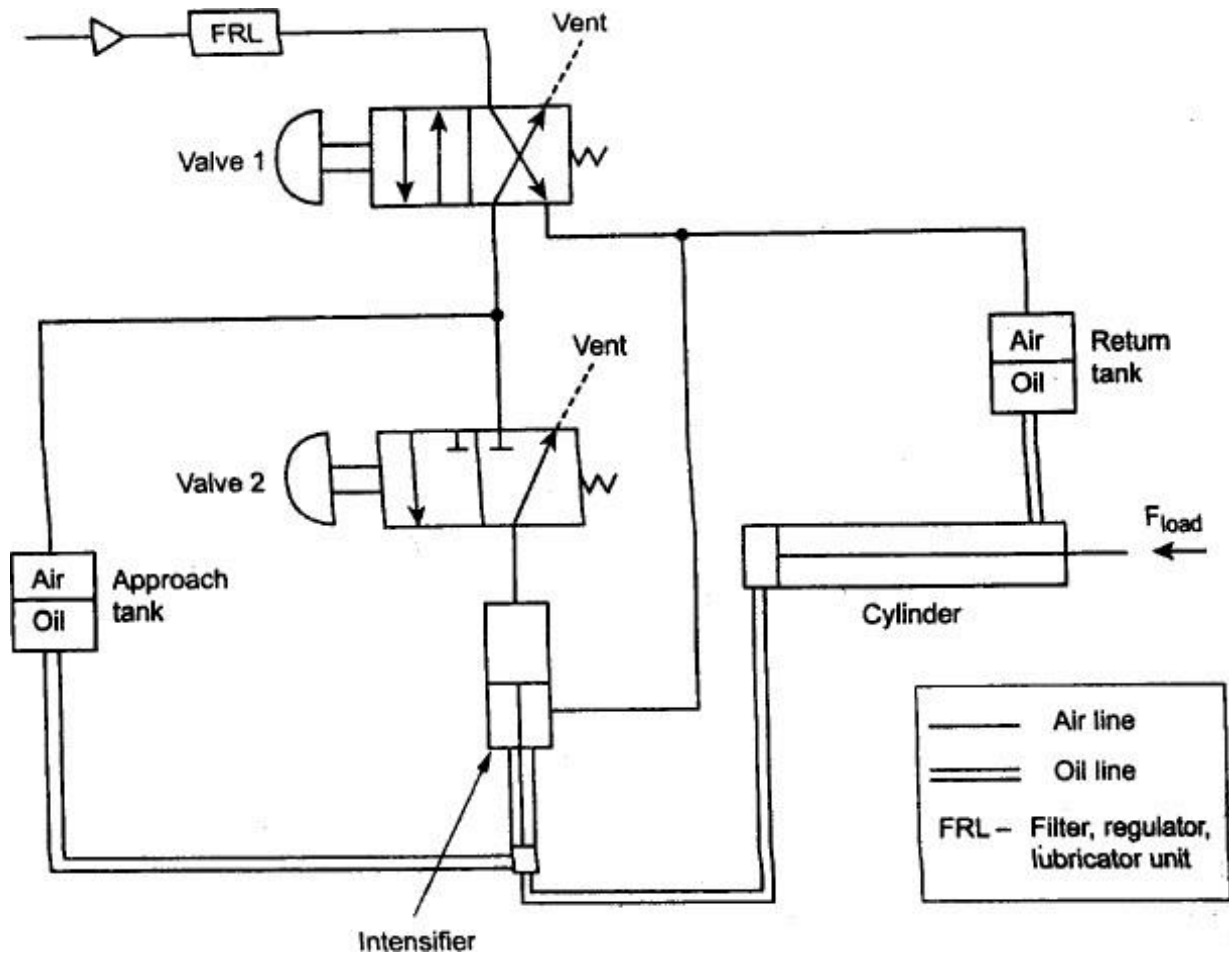

### Air-Over-Oil Intensifier Circuit

When the valve 2 is released, the air flow from the reservoir is blocked. The air from the top end of the intensifier is vented to the atmosphere. This completes the high pressure portion of the cycle. When valve 1 is released, the air flow is diverted to return tank and also the air in the approach tank is vented. The diverted air flow pushes the oil to the rod end of the cylinder. This causes the cylinder to retract. The oil from the piston end of the cylinder is diverted back to the approach tank through the bottom end of the intensifier. This completes the entire cycle of operation.

## INDUSTRIAL HYDRAULIC CIRCUITS

### REGENERATIVE CIRCUIT

It is used to speed up the extending speed of the double acting cylinder. Figure shows a regenerative circuit that can be used to speed up the extending speed of the double acting cylinder.

This circuit uses a manually operated, three position, four way DCV and a double acting cylinder. It should be noted in this circuit that the pipelines to the cylinder are connected in parallel and one of the ports of the DCV is blocked. When the 4/3 DCV is shifted to the left mode, the oil flows from the pump to the blank end of the cylinder. This pump flow extends the cylinder. When the 4/3 DCV is shifted to the right mode, the oil from the pump bypasses the DCV and enters into the rod end of the cylinder. Oil in the blank end drains back to the tank through the DCV as the cylinder retracts. The

speed of extension in the regenerative circuit is greater than that for a regular double acting cylinder. But the speed of retraction is similar to the regular double acting cylinder. This is because oil flow from the rod end regenerates with the pump flow to provide a total flow rate, which is greater than the pump flow rate to the blank end of the cylinder.

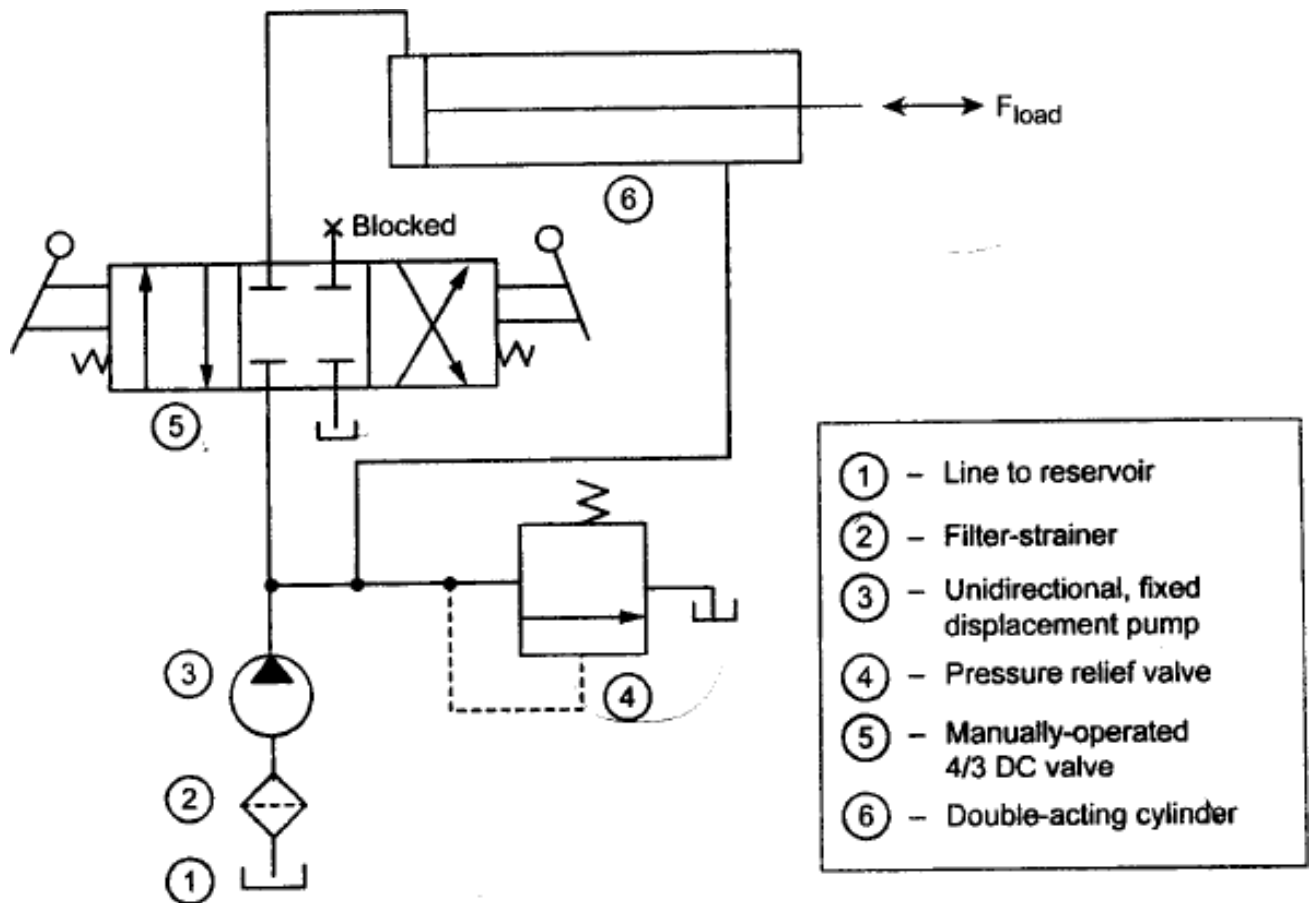

### Regenerative Circuit

### AUTOMATIC CYLINDER RECIPROCATING SYSTEM

The sequence valves can also be used to produce continuous reciprocation of a hydraulic cylinder. Figure shows a circuit that automatic reciprocation of the hydraulic cylinder. This can be achieved by using two sequence valves and a pilot pressure operated spring-centered 4/3 DCV. When the 4/3 DCV is shifted to the flow path configuration, oil flows from the pump to the rod end of the cylinder. This pump flow retracts the cylinder. The check valve prevents shifting of the 4/3

DCV until the full retraction stroke completes. As the piston reaches its end of stroke, the pressure builds up in the sequence valve 1 and it opens. This allows the pilot pressure signal to shift the DCV to the right mode. When the pilot signal shifts the 4/3 DCV to the right mode, the oil flows to the blank end of the cylinder. This pump flow extends the cylinder. The check valve 2 prevents shifting of the DCV until the full extension stroke completes. As the piston reaches its end of stroke, the pressure builds up in the



sequence valve 2 and it opens. This allows the pilot pressure signal to shift the DCV to the left mode again. Thus the sequence repeats and the cylinder reciprocates continuously.

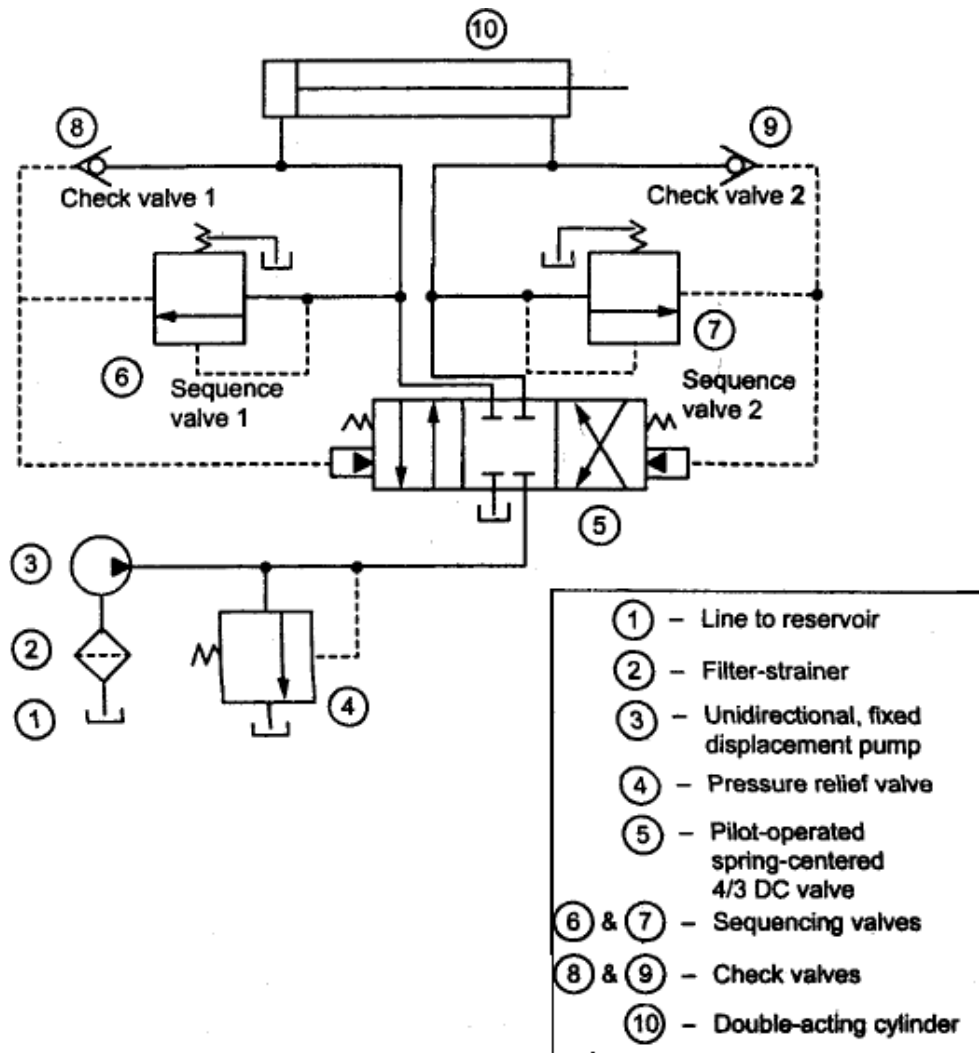

### Automatic Cylinder Reciprocating System

### SYNCHRONIZING HYDRAULIC CYLINDERS

There are many industrial applications require nearly perfect synchronization of movement of two or more cylinders in order to complete some phase of operation. To accomplish the identical task from the cylinders at the same rate, synchronizing circuits are employed. This is achieved by using double-end cylinders in series, by using mechanically linked pistons, by using hydraulic motors as metering devices and by using flow control valves. Figure shows a circuit to synchronize two cylinders by connecting them in series. This circuit uses a solenoid-operated, spring-offset 4/3 DCV and two double acting cylinders. When the 4/3 DCV is shifted to the left envelope flow path configuration, oil flows from the pump to the blank end of cylinder1 and thus the cylinder1

extends. At the same time, oil from the rod end of cylinder1 is forced to the blank end of cylinder2 and thus the cylinder2 also extends. Now the oil returns to the tank from the rod end of the cylinder2 through DCV. Once full extension of cylinder1 and 2 are over the DCV is shifted to the right mode. When the 4/3

DCV is shifted to the right mode, oil flows from the pump to the rod end of cylinder2 and thus the cylinder2 retracts. As the same time, oil from the blank end of cylinder2 is forced to the rod end of cylinder1 and thus the cylinder1 also retracts.

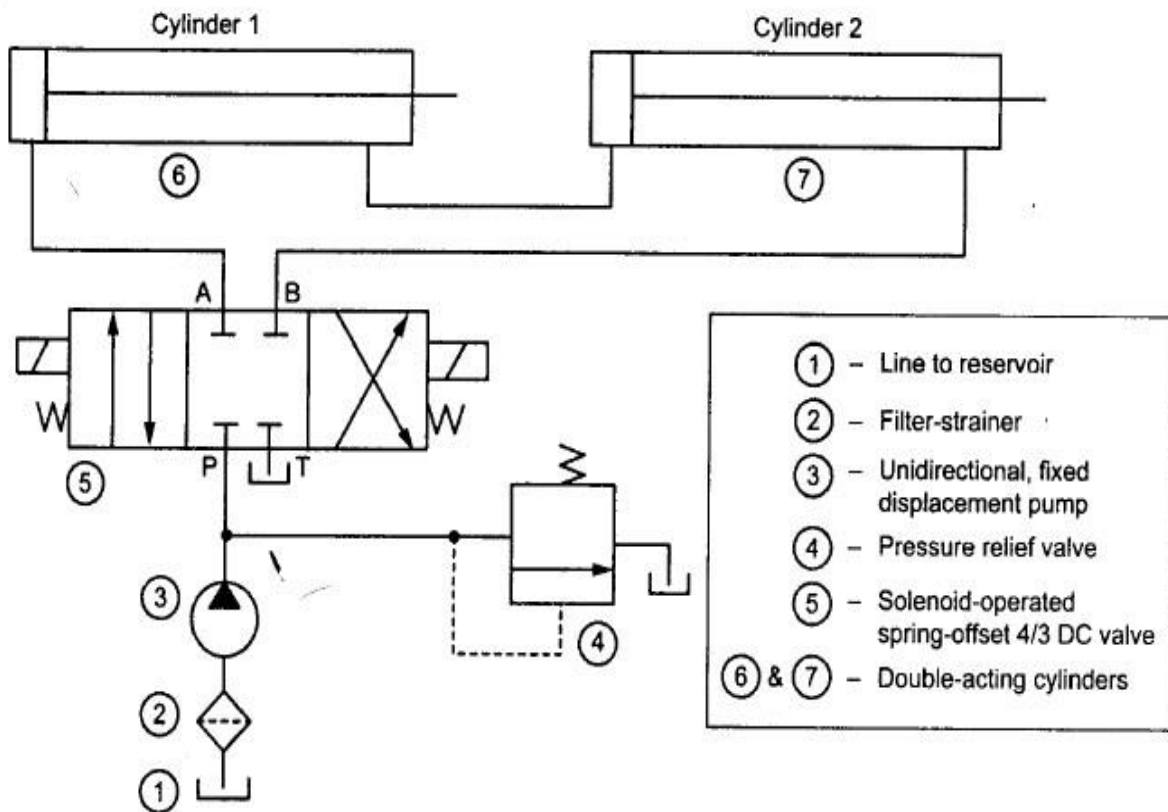

### Synchronizing Hydraulic Cylinders

Now the oil returns to the tank from the blank end of cylinder1 through DCV. Thus both extension and retraction operations of both cylinders are synchronized by connecting them in series. But for the two cylinders to be synchronized, the piston area of cylinder2 should be equal to the difference between the areas of the piston and rod for cylinder1.

### FAIL-SAFE CIRCUIT

Fail-safe circuit is designed to safeguard the operator, the machine and work piece. These circuits prevent any possible injury to the operator or damage to the machine and the work piece. One such fail safe circuit is explained below. It is also called as two handed safety circuit. Figure

shows the two handed safety control circuit. This circuit uses a pilot-operated spring-offset 4/3 DCV and two push buttons. When the 4/3 DCV valve is in its centre position, the oil flows is diverted back to tank through the pressure relief valve. Therefore the cylinder is hydraulically locked. When operator pushes down both left and right push buttons, the oil flows in through port R of pilot valve1 and out through ports, then through port V of pilot valve 2 and out port U. but check valve Z stops flow. At the same time, the oil also flows to pilot connection A of 4/3 DCV causing the DCV to shift to its left mode.

When the cylinder and thus the cylinder extends. Thus extension of cylinder takes place only when the operator depresses both the push buttons. When the operator pushes the right button only, oil flows in through port R to port S of pilot valve1, then through port V to port N of pilot valve2. Thus the oil is drained to the tank through the pilot valve2. This allow the 4/3 DCV to return to neutral position, thus the cylinder is hydraulically locked. When the operator pushes the left push button only, oil flows in port R of pilot valve1 and out port T, then unseats ball in check valve Z, then on to port U of pilot valve2, and out port V. Oil follows the path of least resistance so it passes in port S of pilot valve1, out port M and into sump. It does not build up enough pressure to keep pilot pressure on pilot connection A so 4/3 DCV shifts back to neutral position, thus the cylinder is hydraulically locked. When the operator releases both left and right push buttons, oil flows in port R of pilot valve1 and out port T, then through check valve Z and into port U of pilot valve2. Now the oil flows out port W into pilot connection B of 4/3 DCV shifting its position to right mode. When the 4/3 DCV is shifted to its right mode, the oil from the pump flows into the rod end of the cylinder and hence the cylinder retracts. Thus the retraction of cylinder takes place only when the operator releases both the push buttons.

  
your roots to success...

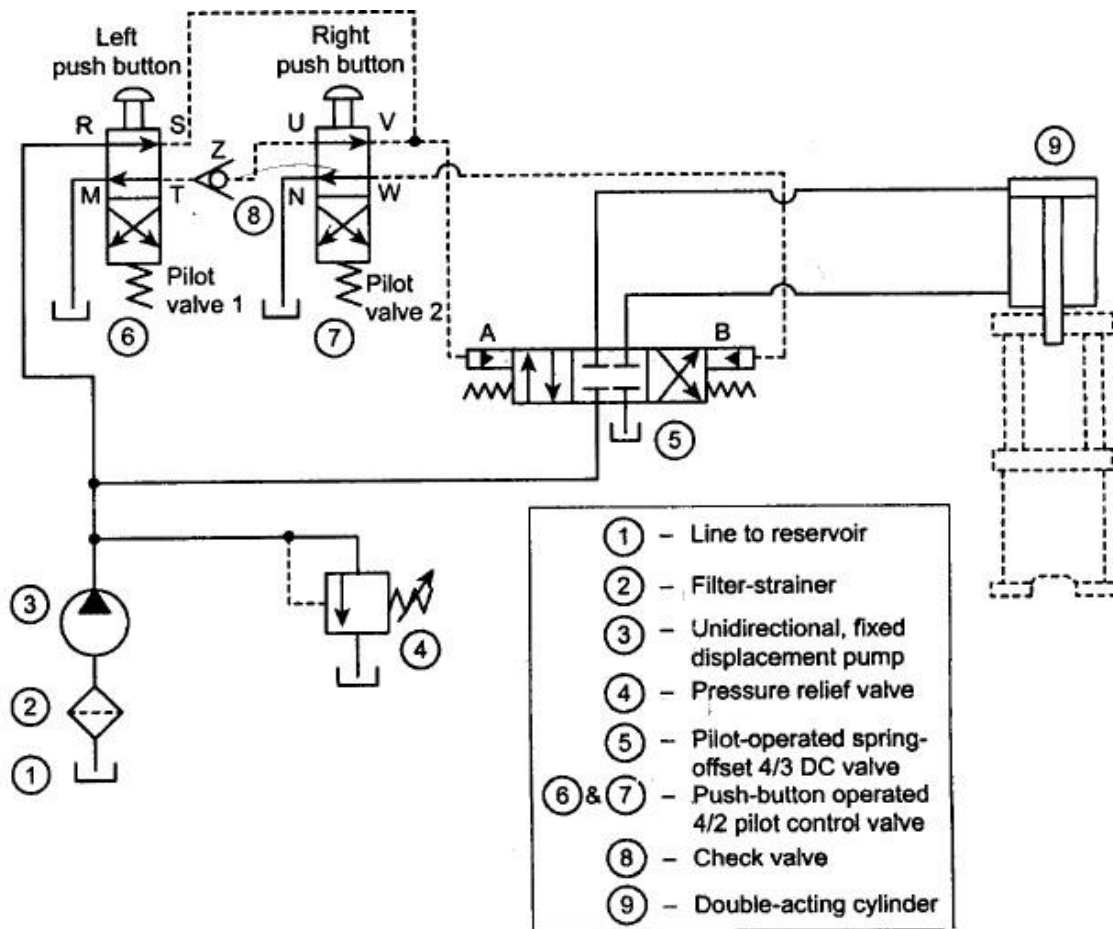

Two Handed Safety Control Circuit

your roots to success...