



your roots to success...

ACCREDITED BY NBA & NAAC WITH A-GRADE
NARSIMHA REDDY ENGINEERING COLLEGE

PERMANENTLY AFFILIATED TO JNTUH, HYDERABAD - APPROVED BY AICTE, NEW DELHI
AN ISO 9001 : 2008 CERTIFIED INSTITUTE



UGC AUTONOMOUS INSTITUTION

COURSE : B.TECH I YEAR
SUBJECT : APPLIED PHYSICS
COURSE CODE : AP1102BS
REGULATION :NR23
FACULTY : MANOJ KUMAR .T
ASSISTANT PROFESSOR
H&S DEPARTMENT

The left side of the page features a decorative design consisting of several vertical stripes of varying shades of light blue and teal. Overlaid on these stripes are several solid teal circles of different sizes, arranged in a cluster that tapers towards the bottom.

UNIT-1

Principles of Quantum Mechanics

FAILURES OF CLASSICAL MECHANICS

It fails to explain

- The stability of atom
- Spectrum of black body radiations
- Photo electric effect
- Compton effect
- Zeeman effect
- Raman effect



There are five main ideas represented in quantum theory:

- Energy is not continuous, but comes in small but discrete units
- The elementary particles behave both like particle as well as waves.
- The movement of these particles is inherently random.
- It is impossible to know both the position and momentum of a particle at the same time.
- The atomic world is not like the world we live in



BLACK BODY

- A black body is a body which absorbs the radiations of all wavelengths incident up on it.
- It neither reflects nor transmits any of the incident radiations and therefore appears black whatever be the colour of radiation.
- When a black body is heated, it emits radiations which are known as black body radiations.
- No actual body is a perfect black body.
- A black body can artificially constructed.



- According to Ferry, a black body consists of a hollow thick double walled sphere, painted lamp black internally and provided a small circular opening to enter the radiations.
- A projection is placed in front of the opening to prevent the direct reflection.
- When a radiation enters, it suffers many reflections inside the sphere and is finally absorbed.

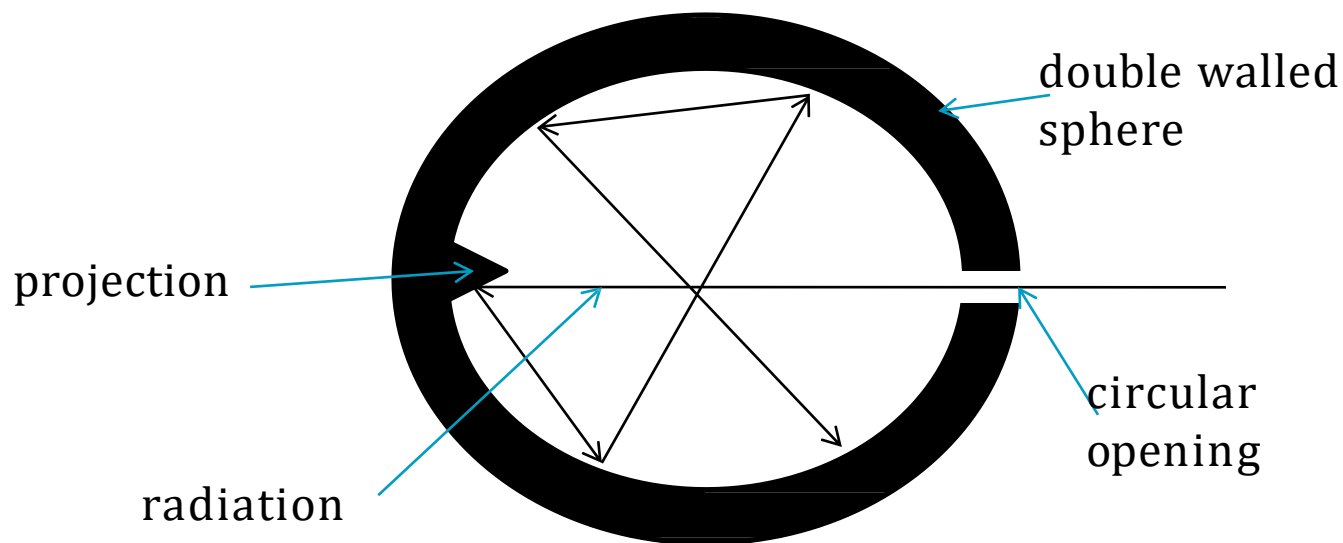

STEFAN'S LAW:

- According to Stefan, when a black body is heated to some temperature T , the total energy emitted by it is directly proportional to fourth power of the temperature.

$$E \propto T^4$$

$$E = \sigma T^4$$

- Where σ is called stefan's constant.



- The distribution of energy in a black body for different wavelengths at different temperatures was experimentally determined by Lumer and Pringshen in 1899. so, according to them,
 - ❖ The emission from a black body at any temperature is composed of radiation of all wavelengths
 - ❖ At a given temperature, the energy is not uniformly distributed. The amount of radiant energy is small at very short and very long wavelengths.
 - ❖ The total energy of radiation at any temperature is given by the area under the curve.
 - ❖ As the temperature of the black body increases, the intensity of the radiation for each wave length increases.



- The wave length corresponding to the maximum energy shift towards shorter wavelength as the temperature increases. This is called Weins-Displacement Law.

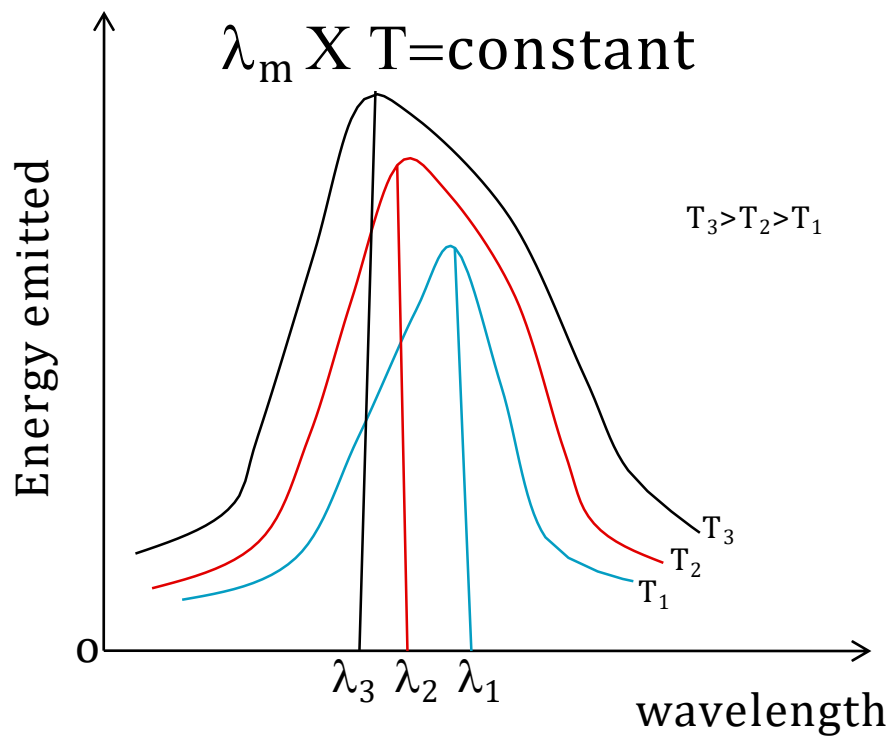

PLANCK'S LAW:

- Statement: According to this law, the energy emitted by a black body with in a wavelength range λ to $\lambda+d\lambda$ is given by

$$E_{\lambda}d\lambda = \left[\frac{8\pi hc}{\lambda^5} \times \frac{1}{\left[\exp\left[\frac{hc}{\lambda KT}\right] - 1 \right]^1} d\lambda \right]$$

- Proof: According to Planck's hypothesis,
 - 1) A black body consists of number of oscillators inside the cavity of the black body.
 - 2) Each oscillator can have discrete set of energies given by,

$$E_n = nh\nu \quad n = 0,1,2,3, \dots \dots \dots$$



- If N is the number of oscillators inside the cavity and E is the total energy. Then, the average energy per oscillator is

$$\bar{E} = \frac{E}{N}$$

- Let $N_0, N_1, N_2, N_3, N_4, \dots$ be the oscillators inside the cavity with energy $0, h\nu, 2h\nu, 3h\nu, 4h\nu, \dots$ respectively.
- Therefore,

$$N = N_0 + N_1 + N_2 + N_3 + N_4 + \dots$$

$$E = (0)N_0 + (h\nu)N_1 + (2h\nu)N_2 + (3h\nu)N_3 + (4h\nu)N_4 + \dots$$

$$E = (h\nu)N_1 + (2h\nu)N_2 + (3h\nu)N_3 + (4h\nu)N_4 + \dots$$



- According to Maxwell-Boltzmann distribution law, the number of oscillators having ($r h \nu$) energy is given by,

$$N_r = N_0 \exp \left[\frac{-r h \nu}{KT} \right]$$

- The total number of oscillators,

$$N = N_0 + N_1 + N_2 + N_3 + N_4 + \dots$$

$$N = N_0 \exp \left[\frac{-0 h \nu}{KT} \right] + N_0 \exp \left[\frac{-1 h \nu}{KT} \right] + N_0 \exp \left[\frac{-2 h \nu}{KT} \right] + N_0 \exp \left[\frac{-3 h \nu}{KT} \right] + \dots$$

$$N = N_0 + N_0 \exp \left[\frac{-h \nu}{KT} \right] + N_0 \exp \left[\frac{-2 h \nu}{KT} \right] + N_0 \exp \left[\frac{-3 h \nu}{KT} \right] + \dots$$

$$N = N_0 \left[1 + \exp \left[\frac{-h \nu}{KT} \right] + \exp \left[\frac{-2 h \nu}{KT} \right] + \exp \left[\frac{-3 h \nu}{KT} \right] + \dots \right]$$

$$N = N_0 \left[1 + \exp \left[\frac{-h \nu}{KT} \right] + \left[\exp \left[\frac{-h \nu}{KT} \right] \right]^2 + \left[\exp \left[\frac{-h \nu}{KT} \right] \right]^3 + \dots \right]$$

$$\text{let } x = \exp \left[\frac{-h \nu}{KT} \right]$$

$$N = N_0 [1 + x + [x]^2 + [x]^3 + \dots]$$

$$N = N_0 [1 - x]^{-1}$$

$$N = \frac{N_0}{[1 - x]} = \frac{N_0}{\left[1 - \exp \left[\frac{-h \nu}{KT} \right] \right]}$$



- The total energy is given by

$$E = (h\nu)N_1 + (2h\nu)N_2 + (3h\nu)N_3 + (4h\nu)N_4 + \dots$$

$$E = \left\{ (h\nu)N_0 \exp\left[\frac{-1h\nu}{KT}\right] \right\} + \left\{ (2h\nu)N_0 \exp\left[\frac{-2h\nu}{KT}\right] \right\} + \left\{ (3h\nu)N_0 \exp\left[\frac{-3h\nu}{KT}\right] \right\} + \dots$$

$$E = \left\{ (h\nu)N_0 \exp\left[\frac{-1h\nu}{KT}\right] \right\} \times \left[1 + \left\{ (2) \exp\left[\frac{-h\nu}{KT}\right] \right\} + \left\{ (3) \exp\left[\frac{-2h\nu}{KT}\right] \right\} + \dots \right]$$

$$\text{let } x = \exp\left[\frac{-h\nu}{KT}\right]$$

$$E = \{(h\nu)N_0 x\} \times [1 + \{(2) x\} + \{(3) x^2\} + \{(4) x^3\} + \dots]$$

$$E = \{(h\nu)N_0 x\} \times [1 - x]^{-2}$$

$$E = \frac{\{(h\nu)N_0 x\}}{[1 - x]^2}$$

$$E = \frac{\left\{ (h\nu)N_0 \exp\left[\frac{-h\nu}{KT}\right] \right\}}{\left[1 - \exp\left[\frac{-h\nu}{KT}\right] \right]^2}$$



- The number of oscillators per unit volume in a frequency range ν to $\nu+d\nu$ is,

$$N = \frac{8\pi\nu^2}{c^3} d\nu$$

- Therefore the energy per unit volume within the frequency range ν to $\nu+d\nu$ is,

$$E_\nu d\nu = N\bar{E}$$

$$E_\nu d\nu = \frac{8\pi\nu^2}{c^3} d\nu \times \frac{(h\nu)}{\left[\exp\left[\frac{h\nu}{KT}\right] - 1\right]^1}$$

$$E_\nu d\nu = \frac{8\pi h\nu^3}{c^3} \times \frac{1}{\left[\exp\left[\frac{h\nu}{KT}\right] - 1\right]^1} d\nu$$

- This is Planck's law in terms of frequency



WIEN'S FORMULA:

- This formula is applicable on shorter wavelength side of the Planck's law

$$E_{\lambda}d\lambda = \left[\frac{8\pi hc}{\lambda^5} \times \frac{1}{\left[\exp\left[\frac{hc}{\lambda KT}\right] - 1 \right]^1} d\lambda \right]$$

Rayleigh jeans formula:

- This formula is applicable on longer wavelength side of the Planck's law

$$E_{\lambda}d\lambda = \left[\frac{8\pi hc}{\lambda^5} \times \frac{1}{\left[\exp\left[\frac{hc}{\lambda KT}\right] - 1 \right]^1} d\lambda \right]$$



PHOTO ELECTRIC EFFECT:

- Statement: When a light of suitable frequency illuminates a metal surface, electrons are emitted from the metal surface. These photo generated electrons are called photo electrons.

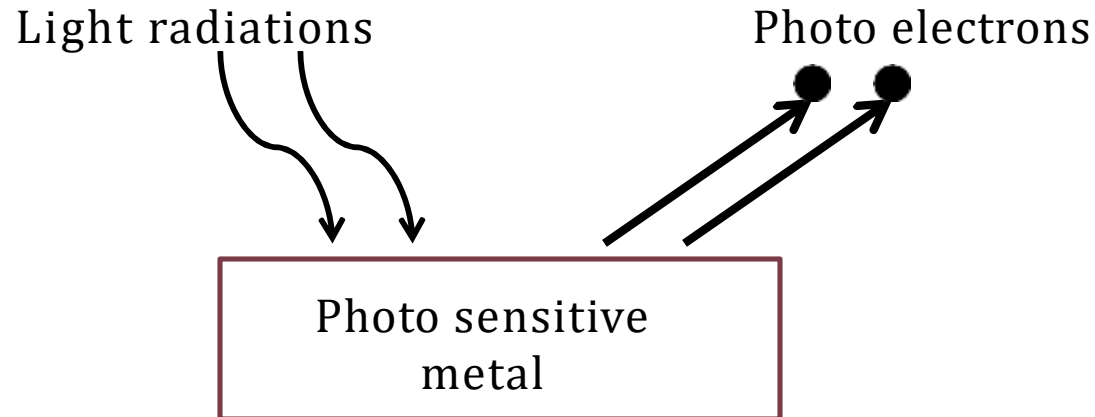

EXPERIMENTAL VERIFICATION:

Arrangement consists of

- Two photo sensitive plates A and B enclosed in a quartz bulb. Plate A is connected to negative terminal of battery and plate B is connected to positive terminal of battery through a ammeter and a resistor. Hence, plate A acts like a cathode and plate B acts like a anode.

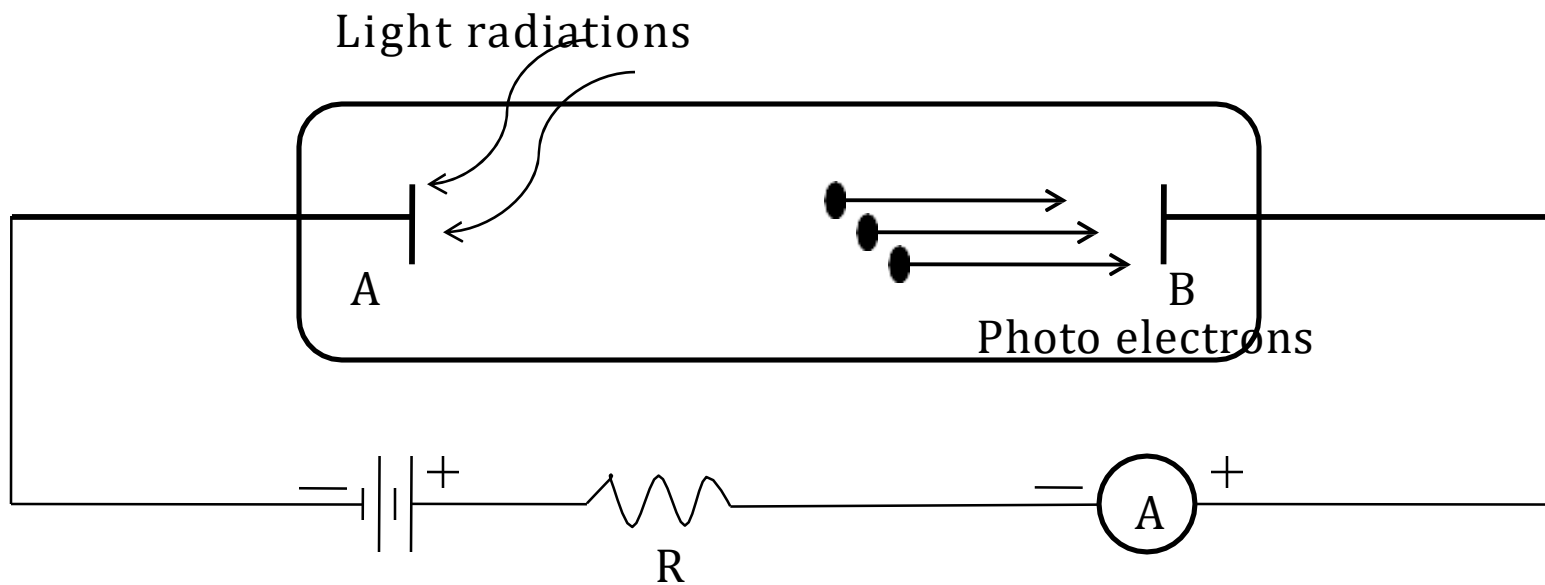

- When light radiations are made to fall on plate A, the photo electrons are emitted by it and are attracted by the anode(plate B). Hence there is a flow of current in the circuit called as photo electric current.
- This photo electric current is a function of
 - ❖ Incident light radiation frequency
 - ❖ Intensity of incident light radiation
 - ❖ Voltage potential across the plates
- Plate A be the metallic surface in which electrons requires a minimum energy to escape out from the metal surface. This minimum energy is called as work function.

$$\Phi = h \nu_0$$



VARIATION OF PHOTO ELECTRIC CURRENT

With frequency of incident radiation:

- Keeping intensity of incident radiation and applied potential as constant, if the frequency of the incident radiation increases, then up to certain frequency called threshold frequency (ν_0), the photo current is zero and after that varies as shown

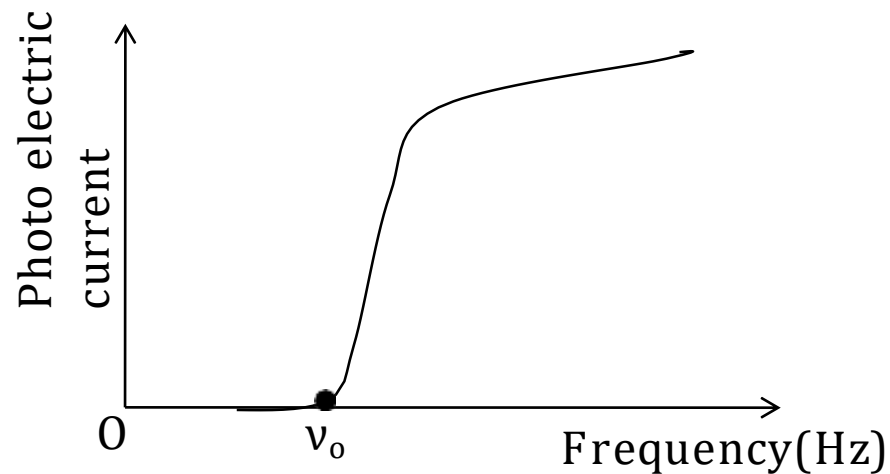

With intensity of incident radiation:

- Keeping applied potential as constant, if the intensity of the incident radiation increases, then the photo current also increases. But the threshold frequency remains constant for a given material even the intensity increases

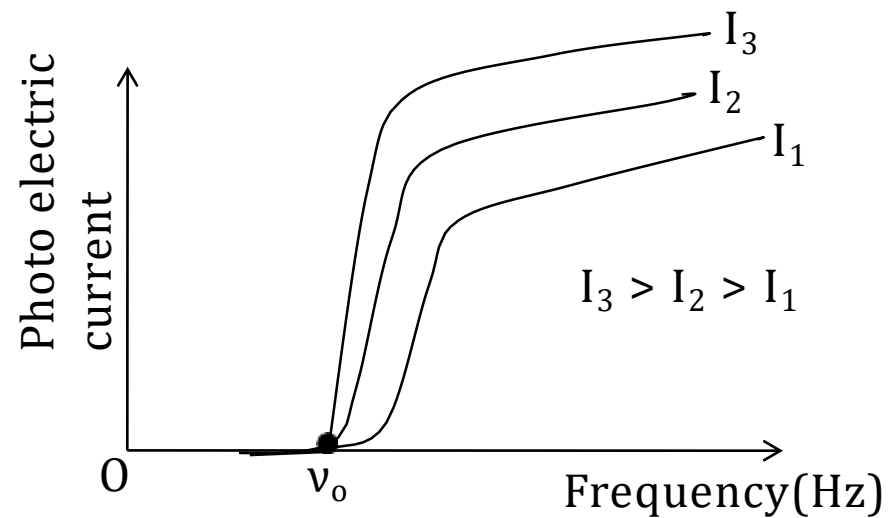

With applied potential:

- Keeping intensity and frequency of radiation as constant, if the applied potential increases, then the photo current also increases and becomes steady.
- Even if the applied potential is zero, there will be certain current in the circuit due to constant incident radiations.

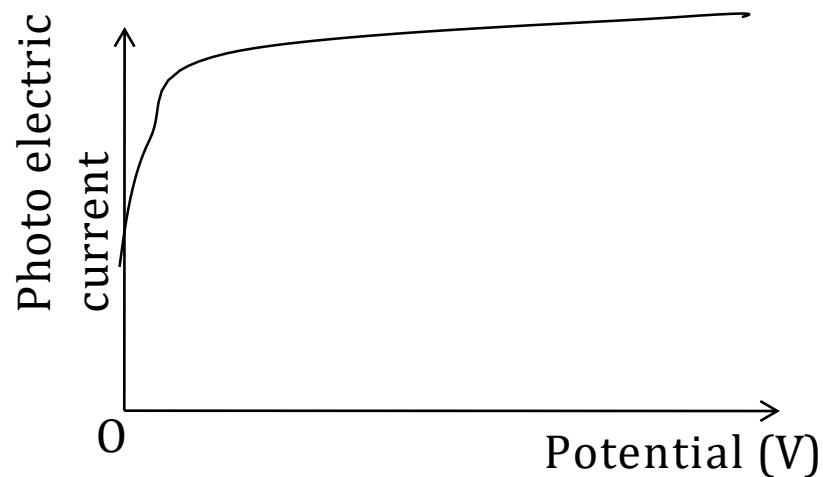

- To make this current as zero if the reverse potential is increased, current decreases and becomes zero at a potential called as stopping potential

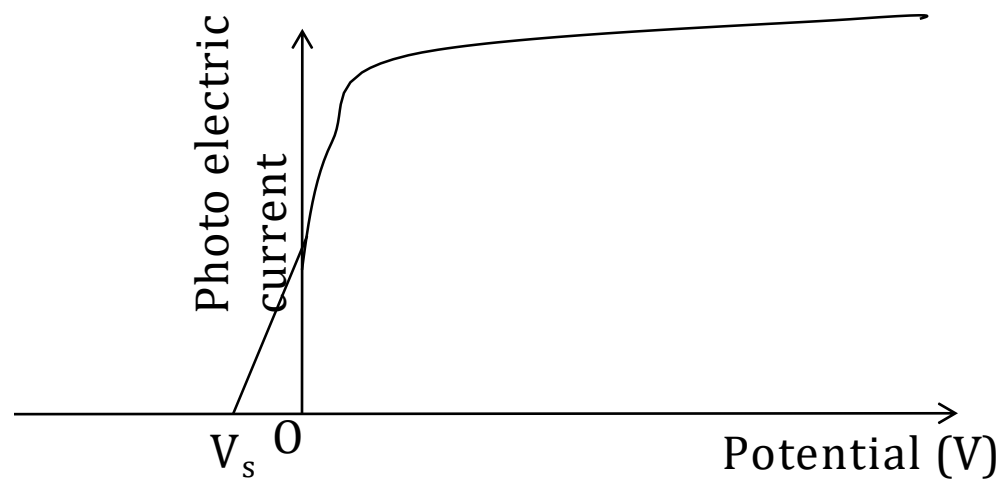

EINSTEIN PHOTO ELECTRIC EQUATION

- According to Einstein, when light of energy ($h\nu$) is incident on a metal surface, a part of incident energy ($h\nu_0$) is utilized to remove electron from the material and remaining energy ($h\nu-h\nu_0$) is appeared as kinetic energy of the electron. Therefore

$$(h\nu-h\nu_0)=K.E$$

$$(h\nu-h\nu_0)=\frac{1}{2} m v^2$$

The above equation is called as Einstein photo electric equation. Where $\phi=h\nu_0$ is called as work function.



WAVES AND PARTICLES

Waves: Wave is a disturbance that propagates through space and time, usually with transference of energy.

❖ Waves travel and transfer energy from one point to another, often with little or no permanent displacement of the particles of the medium.

❖ It is specified by its frequency, wave length, phase or wave velocity, amplitude and intensity.

Particles: A particle has mass and it is located at some definite point.

❖ The particle is specified by its mass, velocity, momentum, energy.



- ❖ In 1924, Louis de- Broglie suggested that matter has dual nature. Matter might exhibit wave like properties under approximate conditions.
- ❖ Louis de Broglie led to the concept of matter waves by considering the following.
 - Since radiations has been shown to possess dual nature. Matter must also possess dual nature.
 - Radiation is supplemented with particle characteristics to explain optical phenomenon, such as photo electric effect.
- ❖ So, a matter wave is defined as the wave associated with a material particle.



DE-BROGLIE HYPOTHESIS

- ❖ In 1924, de-Broglie extended dual nature to material particles or micro particles like electrons, protons, neutrons etc. according to his hypothesis, when particles are accelerated then they will spread like a wave with a certain wave length.
- ❖ The dual nature of matter was explained by combining Planck's equation for energy of a photon,

$$E = h\nu$$

- ❖ And Einstein's mass and energy relation

$$E = mc^2$$



- So,

$$mc^2 = h\theta$$

- We know that velocity of light,

$$c = \theta\lambda$$

- Therefore,

$$mc^2 = h\frac{c}{\lambda}$$

$$\lambda = \frac{h}{mc} = \frac{h}{P}$$

- The above equation indicates that a photon of momentum 'P' is associated with a matter wave.



- Consider a particle of mass m , moving with a velocity v is associated with a matter wave. Then the momentum of the material particle is

$$P = mv$$

- Therefore, wave length associated with it is

$$\lambda = \frac{h}{P} = \frac{h}{mv}$$

- This is known as de-Broglie wave length in terms of velocity.



- Consider a particle of mass m , moving with a velocity v is associated with a matter wave.
- Then kinetic energy of the particle is given by

$$E = \frac{1}{2}mv^2$$

$$2mE = m^2v^2$$

$$\sqrt{2mE} = mv$$

- Therefore, wave length associated with it is

$$\lambda = \frac{h}{p} = \frac{h}{mv} = \frac{h}{\sqrt{2mE}}$$

- This is known as de-Broglie wave length in terms of kinetic energy.



- Consider a charged particle of mass m , moving with a velocity v having a charge q is accelerated to a potential V .

- Then, energy of the particle,

In terms of velocity

In terms of charge $E = \frac{1}{2}mv^2$

$$E = qV$$

Therefore,

$$\frac{1}{2}mv^2 = qV$$

$$m^2v^2 = 2mqV$$

Therefore, wave length associated with it is

$$\lambda = \frac{h}{p} = \frac{h}{mv} = \frac{h}{\sqrt{2mqV}}$$

This is known as de-Broglie wave length in terms of potential.



- Consider an electron of mass m , moving with a velocity v having a charge 'e' is accelerated to a potential V .
- Therefore, wave length associated with it is

$$\lambda = \frac{h}{\sqrt{2meV}}$$

- Substituting, mass of electron, charge of electron we get

$$\lambda = \frac{12.26}{\sqrt{V}} \text{ \AA}$$

$$e = 1.6 \times 10^{-19} \text{ C}$$

$$m = 9.1 \times 10^{-31} \text{ Kg}$$

$$h = 6.65 \times 10^{-34} \text{ J-s}$$

- This is known as de-Broglie wave length in terms of potential only for electrons.



CHARACTERISTICS OF MATTER WAVES:

- The wave associated with a material particle is called as matter wave.

- Since,

$$\lambda = \frac{h}{mv} = \frac{h}{P}$$

- Lighter the particle, greater is the wavelength associated with it.
- Lesser the velocity of particle, longer the wavelength associated with it.
- For $v=0$,. This means that only with moving particles matter waves are associated.
- Whether the particle is charged or not, matter wave is associated with it.

$$w = \frac{c^2}{v} = \left(\frac{1}{v}\right) c^2$$

- Matter waves can travel faster than light.
- Particle and wave nature cannot be exhibited simultaneously.

○



DAVISSON - GERMER EXPERIMENT

EXPERIMENTAL ARRANGEMENT:

The experimental arrangement consists of an electron gun G, which produces fast moving electron beam passed through slits s_1 and s_2 . the beam of electrons are directed to fall on a large single crystal of nickel having atomic spacing of 0.09nm known as target material T. the reflected electrons from 'ni' crystal are collected by an ionization chamber which is connected to an galvanometer to measure the current. The ionisation chamber 'C' which is connected to the galvanometer is movable on the graded scale 'S' between 29 to 90 to receive the reflected electrons from target material.



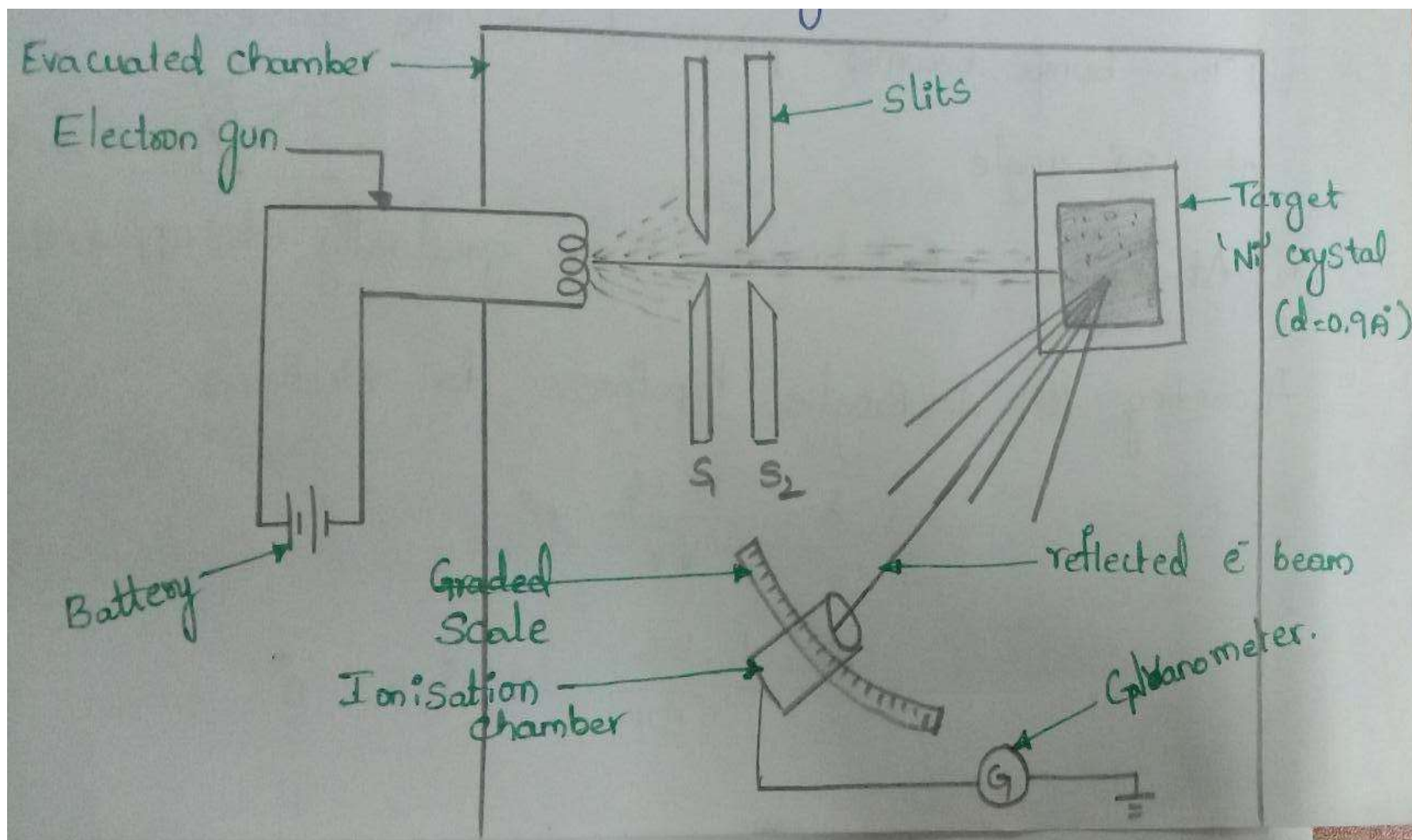

- A retarding potential is maintained between them so that only fast moving electrons coming from the electron gun may enter inside it.
- The secondary electrons if any, generated at the surface of nickel are stopped by the retarding potential.
- Thus the galvanometer connected to ionization chamber C shows deflection due to electrons from the electron gun only.



Working:

keeping accelerating potential a constant, the ionization chamber is moved to various position on the scale 'S' and the galvanometer current is noted for each position.

the experiment is repeated for different potentials and graphs are drawn between angle and current at each potential



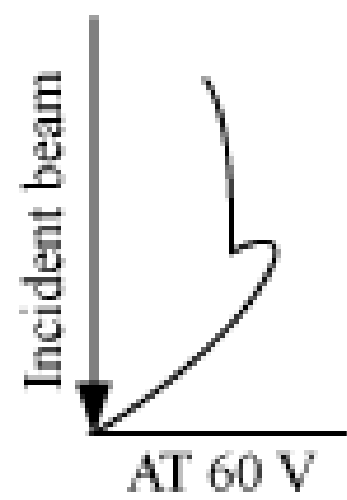
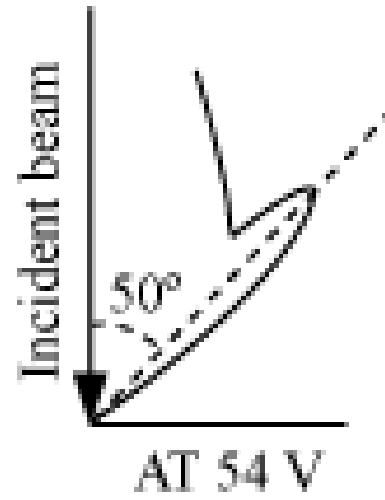
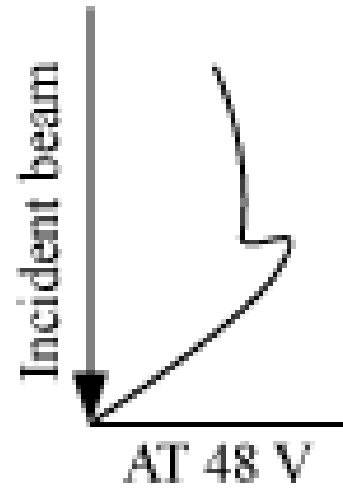
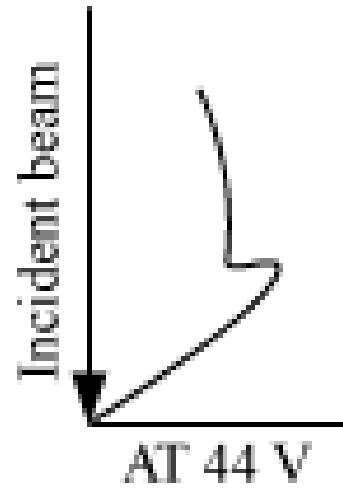

OBSERVATIONS:

From graph,

1. With increasing potentials, the bump moves upwards.
2. The bump becomes prominent in the curve for 54 volts at 50 angle
3. At higher potentials, the bump gradually disappears.



ANALYSATION:

According to de-Broglie hypothesis, for electrons

$$\lambda = \frac{12.26}{\sqrt{V}} \text{ \AA}$$

At $V=54$ volts

$$\lambda = \frac{12.26}{\sqrt{54}} = 1.67 \text{ \AA}$$



According to Braggs law,

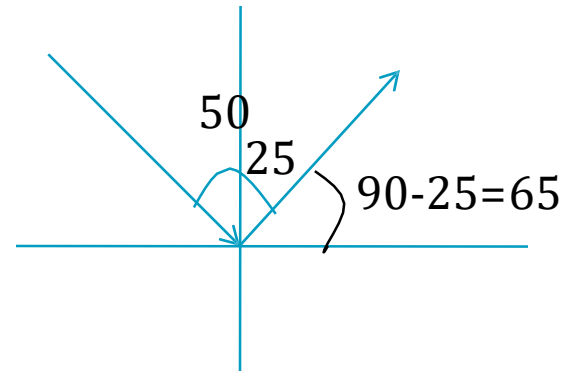

$$\lambda = 2d \sin \theta$$

$$\lambda = 2(0.09 \times 10^{-9}) \sin 65 = 1.63 \text{ \AA}$$

- As the two values are in good agreement, this experiment confirms the de-Broglie concept of matter waves.



SCHRODINGER WAVE EQUATION

- Schrodinger in 1926 developed a wave equation for the moving particles. If a particle of mass 'm' moving with a velocity v is associated with a group of waves.

- Let Ψ be the wave function of the particle

$$\varphi = \varphi_0 \sin(\omega t - Kx) \dots \dots \dots (1)$$

where $K=2\pi/\lambda$

- Differentiating twice the eq. (1)

$$\frac{\partial^2 \varphi}{\partial x^2} = -K^2 \varphi_0 \sin(\omega t - Kx) = -K^2 \varphi \dots \dots \dots (2)$$



$$\frac{\partial^2 \varphi}{\partial x^2} + K^2 \varphi = 0$$

$$\frac{\partial^2 \varphi}{\partial x^2} + \frac{4\pi^2}{\lambda^2} \varphi = 0 \dots \dots \dots (3)$$

From de-Broglie wavelength,

$$\lambda = \frac{h}{mv} \dots \dots \dots (4)$$

From (3) & (4),

$$\frac{\partial^2 \varphi}{\partial x^2} + \frac{4\pi^2 m^2 v^2}{h^2} \varphi = 0 \dots \dots \dots (5)$$

If E is total energy and K & V are kinetic and potential energies then

$$E = K + V$$

$$K = E - V$$



$$\frac{1}{2}mv^2 = E - V$$

$$m^2v^2 = 2m(E - V) \dots \dots \dots (6)$$

- From (5) & (6)

$$\frac{\partial^2 \varphi}{\partial x^2} + \frac{4\pi^2}{h^2} 2m(E - V)\varphi = 0$$

$$\frac{\partial^2 \varphi}{\partial x^2} + \frac{8\pi^2}{h^2} m(E - V)\varphi = 0$$

- Since, $\hbar = h/2\pi$. The above equation becomes,

$$\frac{\partial^2 \varphi}{\partial x^2} + \frac{2}{\hbar^2} m(E - V)\varphi = 0 \dots \dots \dots (7)$$

- This is the Schrodinger wave equation in 1-D.



- For 3-D,

$$\frac{\partial^2 \varphi}{\partial x^2} + \frac{\partial^2 \varphi}{\partial y^2} + \frac{\partial^2 \varphi}{\partial z^2} + \frac{8\pi^2}{h^2} m(E - V)\varphi = 0 \dots \dots \dots (8)$$

- Using laplacian operator,

$$\nabla^2 = \frac{\partial^2}{\partial x^2} + \frac{\partial^2}{\partial y^2} + \frac{\partial^2}{\partial z^2}$$

- From (8)

$$\nabla^2 \varphi + \frac{2}{h^2} m(E - V)\varphi = 0$$

- This is the Schrodinger wave equation.
- Since time factor doesn't appear in the above equation this is called Schrodinger time independent equation.

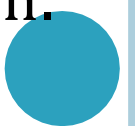

PHYSICAL SIGNIFICANCE OF:-

- The wave function Ψ has no direct physical meaning.
- To explain the relation of particle to wave packet Max Born proposed the physical significance of Ψ .
- According to Born $\Psi \Psi^* = |\Psi|^2$ gives the probability of finding the particle in the state.
- That is Ψ^2 is a measure of probability density.
- For the total probability of finding the particle somewhere is
- Satisfying above requirements is said to be normalised.

$$\iiint |\varphi|^2 dx dy dz = 1$$

- With normalization condition Ψ should also satisfy the following conditions.
 - Ψ should be single valued function
 - Ψ should be a continuous function
 - Ψ should be a finite function



PARTICLE IN ONE DIMENSIONAL POTENTIAL BOX

- Consider a particle of mass 'm' moving along X-axis between the two rigid walls A and B at $x=0$ and $x=a$. the particle is free to move between the walls.
- The potential energy is constant between the walls because no force is acting on the particle.
- Since the particle strikes the walls and get reflected back.
- So, the force acting on the particle abruptly changes from zero to a finite value F with in a distance of zero at the wall.
- We know that

$$|F| = \frac{\partial V}{\partial x}$$



- Therefore,

$\Delta V \rightarrow 0$ as $\Delta x \rightarrow \infty$ such that $\frac{\partial V}{\partial x}$ has a finite value.

- So, potential energy of particle becomes infinite at the walls. Therefore,

$$V(x) = \infty \quad \text{for } x < 0 \text{ and } x > a$$

- The Schrodinger wave equation for particle is given by

$$\frac{\partial^2 \psi}{\partial x^2} + \frac{8\pi^2 m}{h^2} (E - V) \psi = 0$$



- As $V=0$ between the walls,

$$\frac{\partial^2 \varphi}{\partial x^2} + \frac{8\pi^2}{h^2} m(E) \varphi = 0$$

- Let

$$\frac{8\pi^2}{h^2} m(E) = K^2.$$

- Therefore,

$$\frac{\partial^2 \varphi}{\partial x^2} + K^2 \varphi = 0$$

- The solution of above 2nd order differential equation is

- Where A & B are constants, which are obtained by applying the boundary conditions.

$$\varphi = 0 \text{ at } x = 0, x = a$$



- $\Psi=0$ at $x=0$

$$0=A \sin 0 + B \cos 0$$

$$B=0$$

$$\varphi(x) = A \sin Kx$$

- $\Psi=0$ at $x=a$

$$0=A \sin Ka$$

Either $A=0$ or $\sin Ka=0$

But $A \neq 0$

Because if $A=0$ the entire function will be zero as $B=0$.



- Therefore,

$$\sin Ka=0$$

$$Ka = n\pi$$

$$K = n\pi/a$$

- Therefore wave function becomes,

- We know that
$$\varphi(x) = A \sin \frac{n\pi}{a} x$$

$$K^2 = \left(\frac{n\pi}{a}\right)^2 \quad \& \quad \frac{8\pi^2}{h^2} m(E) = K^2.$$

- Therefore,



$$\frac{8\pi^2 m E}{h^2} = \frac{n^2 \pi^2}{a^2}$$

$$\frac{8mE}{h^2} = \frac{n^2}{a^2}$$

$$E_n = \frac{n^2 h^2}{8ma^2}$$

- From the above equation it is clear that the particle can have only discrete set of values of energy.
- That is energy is quantised.

○ For n=1,

$$E_1 = \frac{1^2 h^2}{8ma^2} = \frac{h^2}{8ma^2}$$

○ For n=2,

$$E_2 = \frac{2^2 h^2}{8ma^2} = 2^2 \frac{h^2}{8ma^2} = 2^2 E_1$$

○ For n=3,

○ In general, $E_3 = \frac{3^2 h^2}{8ma^2} = 3^2 \frac{h^2}{8ma^2} = 3^2 E_1$

$$E_n = n^2 E_1$$

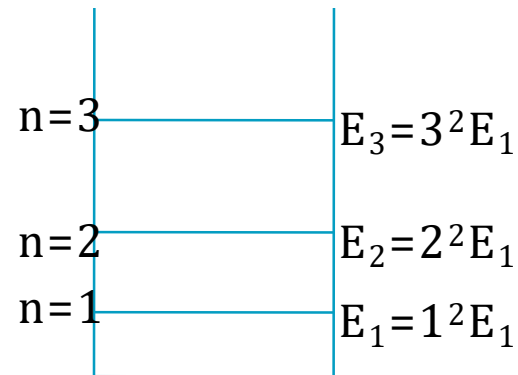

- The value of A can be obtained by applying normalisation condition given in below equation
- Since the particle is inside the box of length 'a', the pbb. of finding the particle inside the box is unity.

- Since the particle is moving in 1-d box,

$$\int_0^a |\varphi|^2 dx = 1$$

$$\int_0^a \left(A \sin \frac{n\pi}{a} x \right)^2 dx = 1$$

$$\int_0^a A^2 \sin^2 \frac{n\pi}{a} x dx = 1$$



$$A^2 \int_0^a \sin^2 \frac{n\pi}{a} x \, dx = 1$$

$$\cos 2\theta = 1 - 2 \sin^2 \theta$$

$$A^2 \int_0^a \frac{1}{2} \left(1 - \cos 2 \frac{n\pi}{a} x \right) dx = 1$$

$$2 \sin^2 \theta = 1 - \cos 2\theta$$

$$\sin^2 \theta = \frac{1}{2} (1 - \cos 2\theta)$$

$$\frac{A^2}{2} \int_0^a \left(1 - \cos 2 \frac{n\pi}{a} x \right) dx = 1$$

$$\frac{A^2}{2} \left(x - \frac{a}{2n\pi} \sin 2 \frac{n\pi}{a} x \right) = 1 \text{ (with limits 0 to a)}$$

- By applying limits,

$$\frac{A^2}{2} \left((a - 0) - \frac{a}{2n\pi} \left(\sin 2 \frac{n\pi}{a} a - \sin 2 \frac{n\pi}{a} 0 \right) \right) = 1$$

$$\frac{A^2}{2} (a - 0) = 1$$

$$A^2 = \frac{2}{a}$$



$$A = \sqrt{\frac{2}{a}}$$

- The normalised wave function is

$$\varphi_n(x) = \sqrt{\frac{2}{a}} \sin \frac{n\pi}{a} x$$

- The wave function Ψ_n and corresponding energies E_n , which are often called Eigen function and Eigen values respectively.

- In 3-D,

$$\varphi_n = \sqrt{\frac{2}{a}} \sqrt{\frac{2}{b}} \sqrt{\frac{2}{c}} \sin \frac{n_1\pi}{a} x \sin \frac{n_2\pi}{b} y \sin \frac{n_3\pi}{c} z$$

$$E_n = \frac{n^2 h^2}{8ma^2}, n^2 = n_1^2 + n_2^2 + n_3^2$$



The left side of the slide features a decorative graphic consisting of several vertical stripes of varying shades of light blue and teal, and a cluster of five solid teal circles of different sizes arranged in a roughly circular pattern.

UNIT-2

Semiconductor Physics

ENERGY BANDS OF SOLIDS:-

- In an isolated atom, the electrons are tightly bound and have discrete, sharp energy levels.
 - A metal or any solid contains a large no. of atoms. These are very close to each other.
 - As the interatomic distance decreases, the allowed energy levels of electron of one atom overlaps with those of neighboring atoms.
 - Hence in a solid the energy level corresponding to any one quantum no. splits up into many closely spaced levels, thus forming a band of energy.
- 

- The width of this band depends on the degree of overlap of electrons of adjacent atoms and is largest for the outermost atomic electrons.
- The electrons in the lower energy bands are of no importance in determining electrical properties of solids. Hence, the electrons in the outermost bands of solids are important in determining many of the physical properties of solids.



- Therefore, the allowed energy bands are valence and conduction bands. The band corresponding to outer most orbit is called conduction band, next inner band is called valence band.
- The energy gap between these two allowed bands is called forbidden energy gap. In this gap, electrons cannot have energy values.



- Valence band is occupied by valence electrons and conduction band which is vacant at 0 K.
- According to the width of the gap between the bands and band occupation by electrons, all solids can be classified broadly in to three groups, namely metals, semiconductors and insulators.



CLASSIFICATION OF SOLIDS:-

- In solids the gap between the two outer most allowed energy bands depends on the equilibrium spacing between the atoms.
- **Insulators:** if the energy band gap is wide enough, say of the order of 5-10 eV, then it is virtually impossible at all the practical temperatures to thermally excite an appreciable no. of electrons across this gap from the top of the highest filled band to the bottom of the lowest empty band.
- Eg: - diamond with a band gap, 7eV.



- **Semiconductors:** - if the band gap between the highest filled and the lowest empty bands is quite small, say of the order 1 eV or less, then there will be an appreciable no. of electrons that will be excited thermally from states near the top of the filled band to states near the bottom of the next empty band across the band gap.
- Eg: germanium with energy gap 0.78 eV, silicon with energy gap 1.21 eV.
- All semiconductors become insulators as the temperature approaches absolute zero. At sufficiently high temperatures, all insulators must exhibit semiconductor behaviour.



- **Conductors:-** solids which are having a great no. of the free electrons in the outer most valence band which is partially filled, then those solids are called conductors.
- They conduct electricity at all temperatures.
- The electrical conductivity of a conductor is much larger than that of a semiconductor due to its large concentration of free electrons.



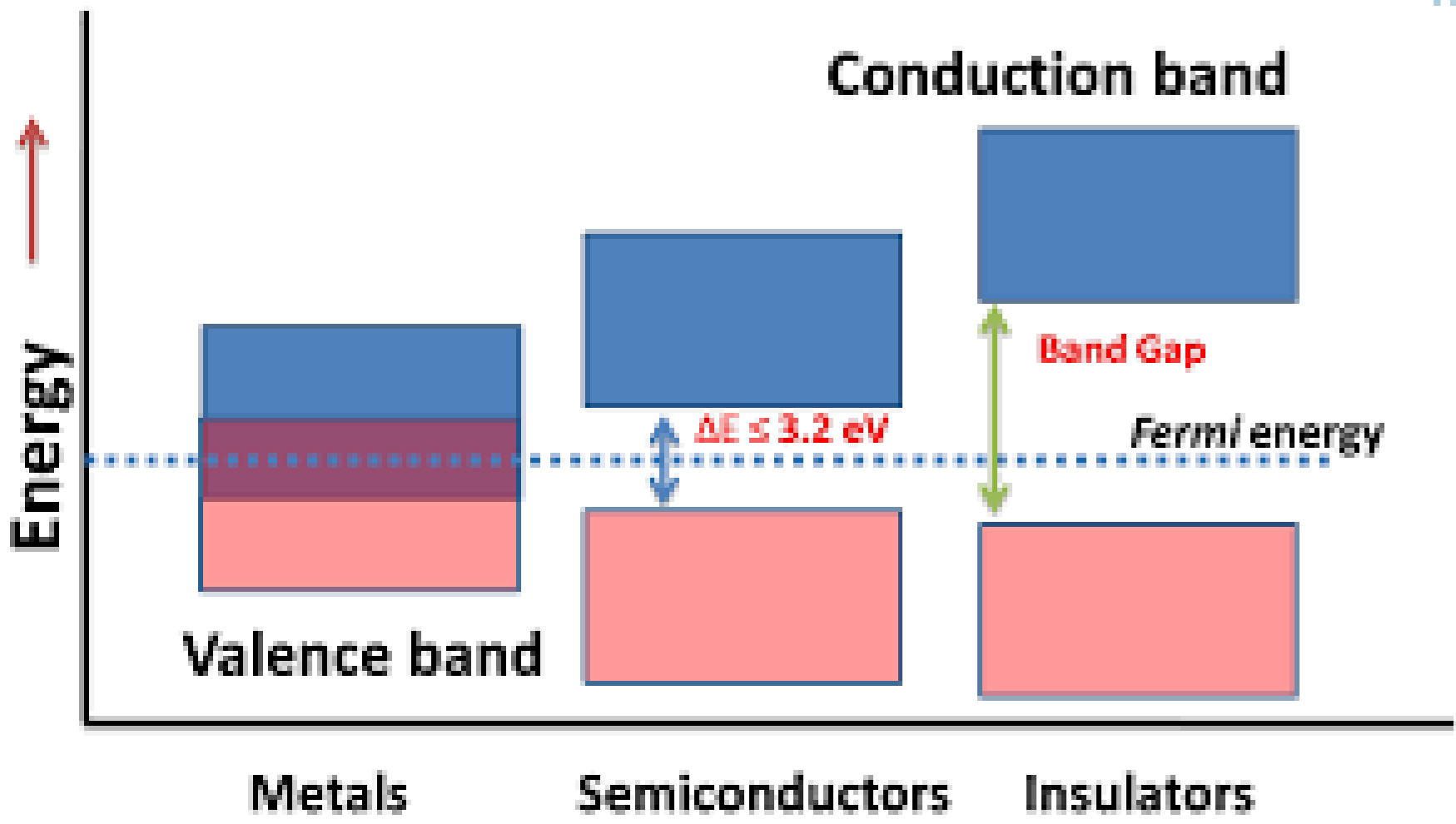

INTRINSIC SEMICONDUCTORS:

- An intrinsic (pure) semiconductor, also called an undoped semiconductor or i-type semiconductor, is a **pure semiconductor without any significant dopant species present.**
- The number of charge carriers is therefore determined by the properties of the material itself instead of the amount of impurities.
- **Silicon and germanium** are examples of i-type semiconductors.



- The band structure of intrinsic semiconductors at 0 K is not unlike to that of insulators.
- There is a vacant conduction band separated by an energy gap from a filled valence band.
- At absolute zero, the electric conduction is not possible.
- But as the temperature is increased, the electrons are thermally excited from the valence band to the conduction band. Where they become free and the conduction is possible.
- Hence, the electron-hole pairs are created. The no. of electrons in the conduction band will be equal to the no. of holes in the valence band.



- Energy band diagram of intrinsic semiconductor at 0 and T kelvin temperature:

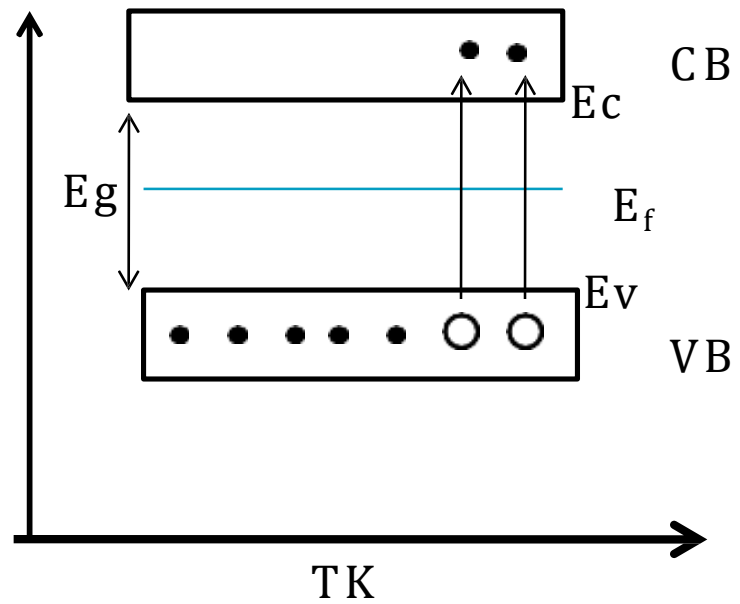
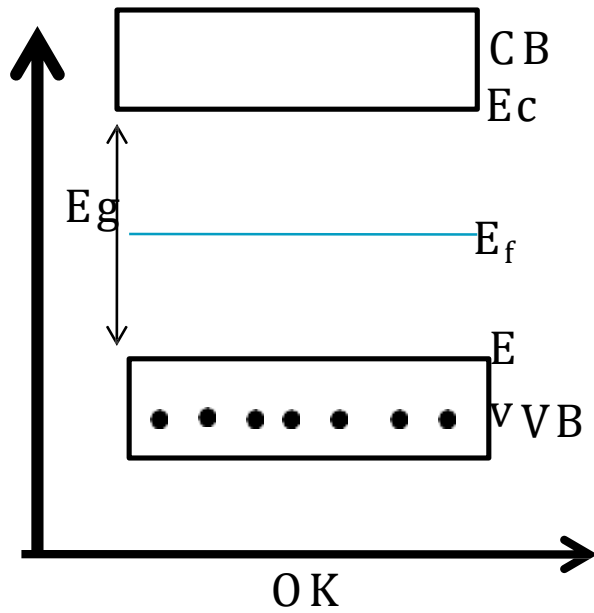

○ Intrinsic carrier concentration:-

In intrinsic semiconductor,

$$n=p$$

Hence $n=p=n_i$ is called intrinsic carrier concentration.

Therefore,

$$\begin{aligned}n_i^2 = np &= 4 \left[\frac{2\pi KT}{h^2} \right]^3 (m_e^* m_h^*)^{3/2} \exp \left[\frac{(E_v - E_c)}{KT} \right] \\ &= 4 \left[\frac{2\pi KT}{h^2} \right]^3 (m_e^* m_h^*)^{3/2} \exp \left[\frac{(-E_g)}{KT} \right]\end{aligned}$$

Where $(E_v - E_c) = -E_g$ is the forbidden energy gap.

Hence,

$$n_i = 2 \left[\frac{2\pi KT}{h^2} \right]^{3/2} (m_e^* m_h^*)^{3/4} \exp \left[\frac{(-E_g)}{2KT} \right]$$



- **Fermi level:**

Since $n=p$ in intrinsic semiconductor,

$$2 \left[\frac{2\pi m_e^* KT}{h^2} \right]^{3/2} \exp \left[\frac{(E_F - E_c)}{KT} \right] = 2 \left[\frac{2\pi m_h^* KT}{h^2} \right]^{3/2} \exp \left[\frac{(E_v - E_F)}{KT} \right]$$

$$(m_e^*)^{3/2} \exp \left[\frac{(E_F - E_c)}{KT} \right] = (m_h^*)^{3/2} \exp \left[\frac{(E_v - E_F)}{KT} \right]$$

$$\exp \left[\frac{2E_F}{KT} \right] = \left(\frac{m_h^*}{m_e^*} \right)^{3/2} \exp \left(\frac{(E_v + E_c)}{KT} \right)$$

Taking log on both sides

$$\left[\frac{2E_F}{KT} \right] = \frac{3}{2} \log \left(\frac{m_h^*}{m_e^*} \right) + \left(\frac{(E_v + E_c)}{KT} \right)$$



$$E_F = \frac{3KT}{4} \log \left(\frac{m_h^*}{m_e^*} \right) + \left(\frac{E_v + E_c}{2} \right)$$

- If we assume, $m_e^* = m_h^*$. Then

$$E_F = \left(\frac{E_v + E_c}{2} \right)$$

- Thus, Fermi level is located half way between the valence band and conduction bands and its position is independent of temperature.
- Since $m_h^* > m_e^*$, E_F is just above the middle and rises slightly with increasing temperature.



- Variation of fermi level with temperature:

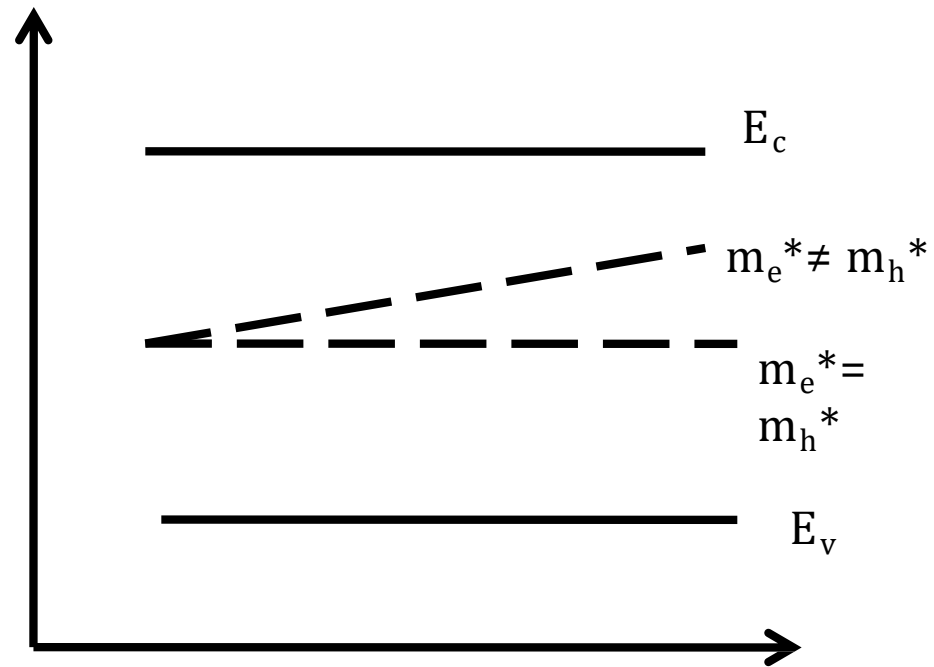

EXTRINSIC SEMICONDUCTOR:-

- A semiconducting material in which the charge carrier originates from impurity atoms added to the material is called impurity semiconductor or extrinsic semiconductor.
- The electrical properties of pure semiconductors are drastically modified by addition of certain impurities.
- The process of adding impurity to a pure semiconductor material is called Doping
- There are two types of impurities possible.
 - Pentavalent (Arsenic, Antimony, Bismuth)&
 - Trivalent (Boron, Aluminium, Gallium)



N- TYPE SEMICONDUCTOR:

- Pentavalent elements which are having 5 electrons in its outermost orbit are added to an intrinsic semiconductor in small trace, then the semiconductor formed is called n- type semiconductor.
- Out of 5 electrons of the impurity 4 electrons are bounded to the semiconductor atoms and 1 electron is left free which is weakly bonded to the atom.
- Even for lesser thermal energy, this fifth electron is released leaving the parent atom positively ionised.
- In the energy level diagram, the energy level of the fifth electron is called donor level which is very close to the conduction band.
- The electron in donor level gets excited to conduction band at room temperature only.
- Hence, majority charge carriers in n-type semiconductor are electrons and holes are minority charge carriers.



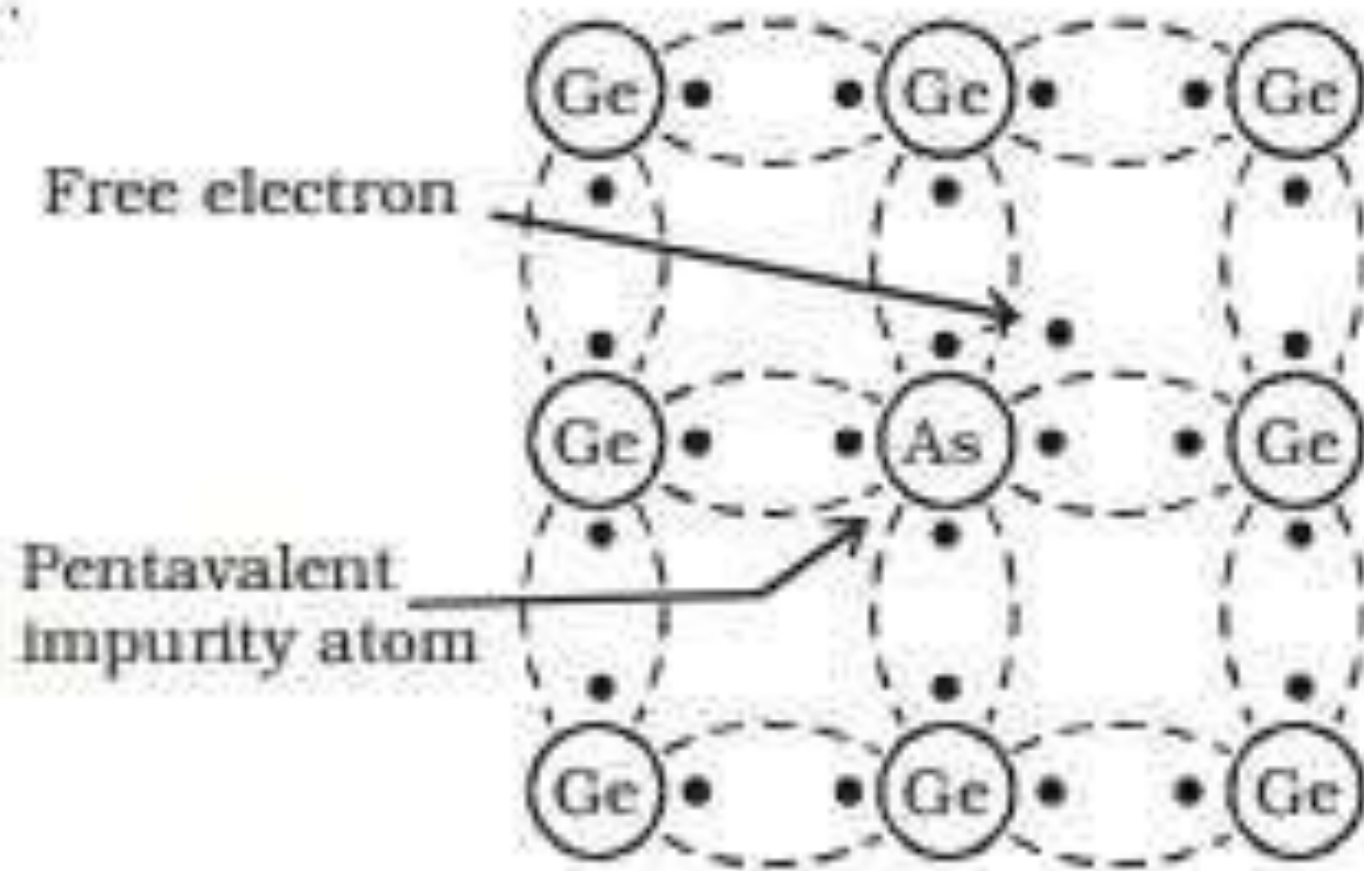
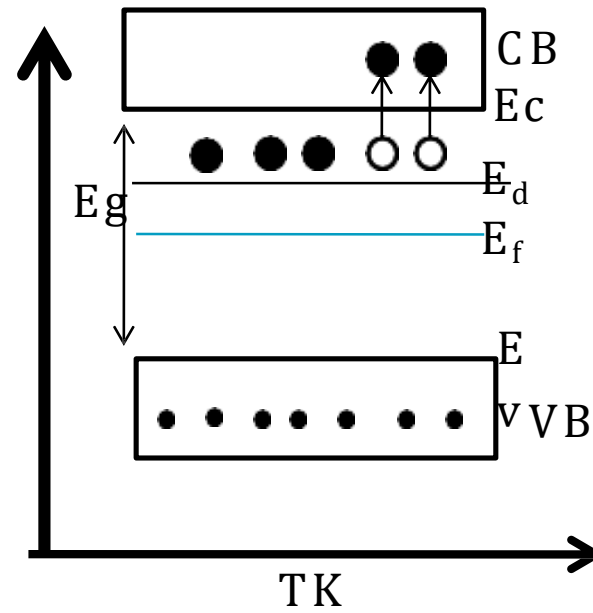
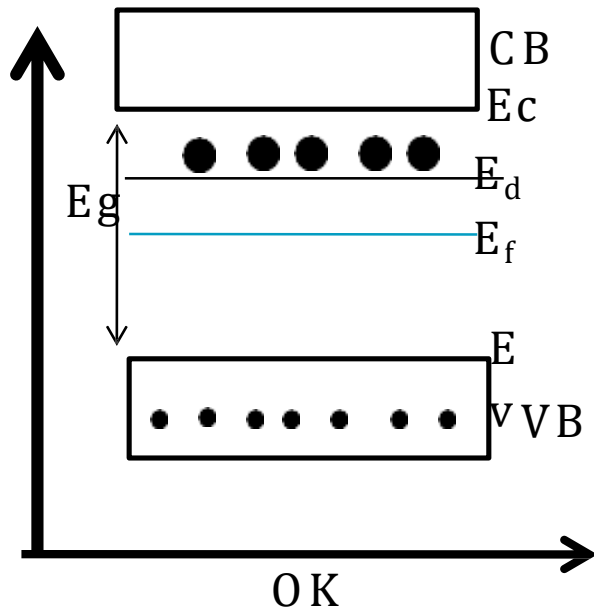

Fig a N-type semiconductor



- Energy band diagram of n-type extrinsic semiconductor at 0 and T kelvin temperature:



○ Fermi energy Vs temperature:

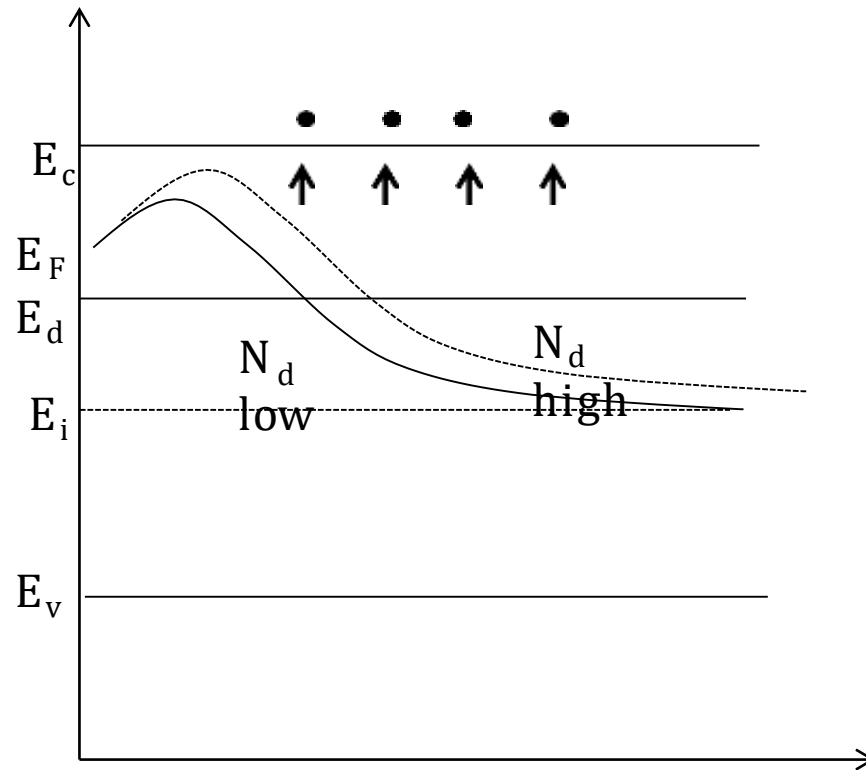

Variation of Fermi level with donor concentration:-

The lowering of Fermi level from E_F to intrinsic Fermi level with the rise of temperature is slow in the case of higher donor concentration material than the lower one.

P-TYPE SEMICONDUCTOR:

- Trivalent elements which are having 3 electrons in its outer most orbits are added to an intrinsic semiconductor in small trace, then the semiconductor formed is called p-type semiconductor.
- All the three electrons are engaged in covalent bonding with three neighbouring semiconducting atoms. It needs one more electron to complete its bond. Since trivalent element accepts one extra electron to complete the bond, the energy level of this impurity atom is called acceptor level.
- This acceptor level lies just above the valence band. Even at relatively low temperatures, the acceptor atoms get ionised taking electron from valence band and thus giving rise to the holes in valence band for conduction.
- Hence, majority charge carriers in p-type semiconductor are holes in valence band and minority charge carriers are electrons.



○ P-Type Extrinsic Semi Conductor

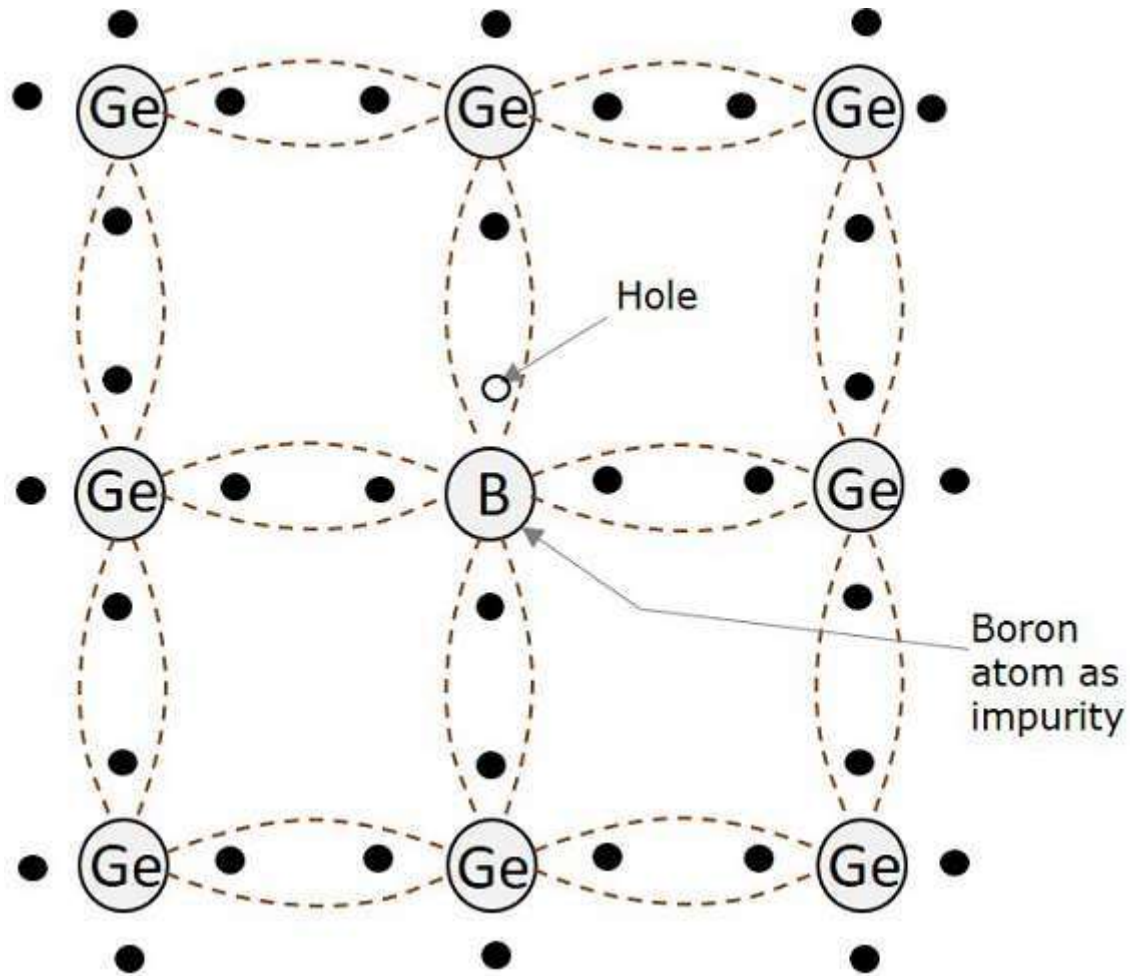

- Energy band diagram of P-Type semiconductor at 0 and T kelvin temperature:

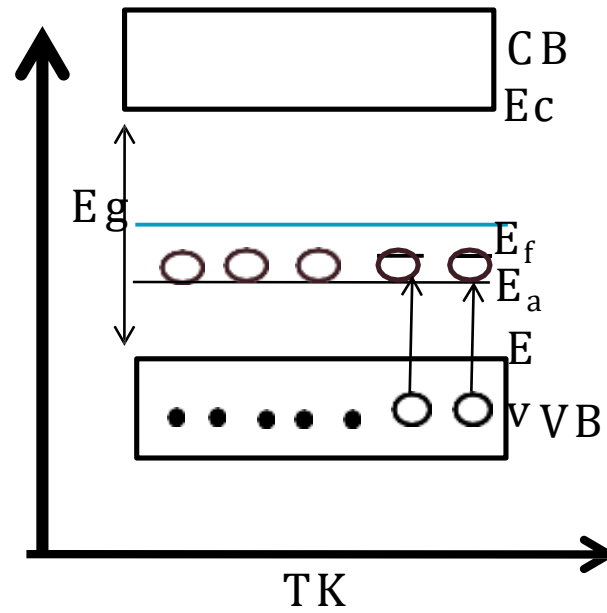
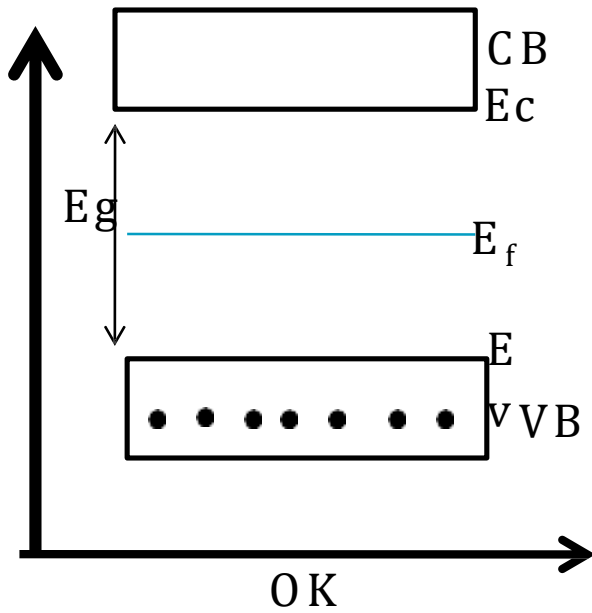

Variation of Fermi level with temperature:-

- With the increase of temperature, E_F decreases slightly as per equation (4).
- As temperature is increased more and more acceptor atoms are ionised and at a particular temperature all acceptor atoms are ionised.
- Further increase of temperature generates electron-hole pairs and material tends to behave as intrinsic semiconductor.
- The Fermi level gradually moves towards intrinsic Fermi level.

Variation of Fermi level with carrier concentration:-

The raising of Fermi level from E_F to intrinsic Fermi level E_i with rise of temperature is slow in case of highly doped one.

- Fermi level Vs temperature

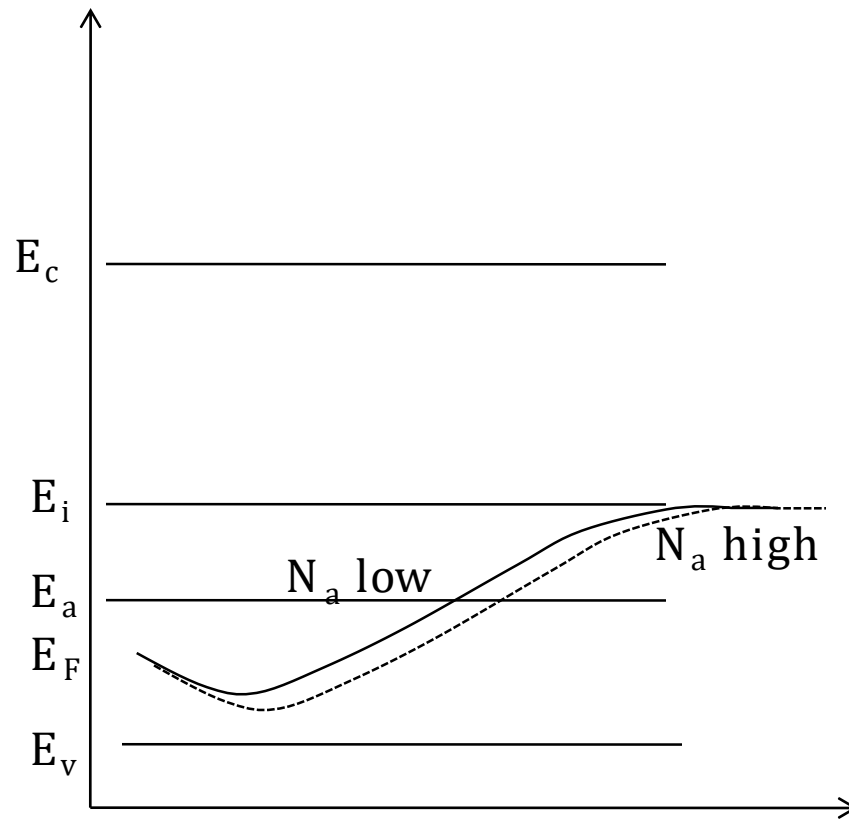

DRIFT AND DIFFUSION MECHANISM

- Any motion of free carriers in a semiconductors leads to a current.
- This motion can be caused by an electric field due to an externally applied voltage, since the carriers are charged particles.
- This transport mechanism is called as carrier drift.
- Carriers also move from regions where the carrier density is high to regions where the carrier density is low.
- This carrier transport mechanism is due to thermal energy and associated random motion of carriers.
- this mechanism is called as carrier diffusion.
- The total current in a semiconductor equals to the sum of the drift and the diffusion currents.



HALL EFFECT:

- **Statement:** Suppose a material carrying an electric current is placed in a magnetic field.
- Then an electric field is produced inside the material in a direction which is at right angles to both the current and the magnetic field.
- This effect was discovered by Edwin H Hall in the year 1879.
- This phenomenon is known as the Hall Effect and the generated voltage is known as hall voltage.



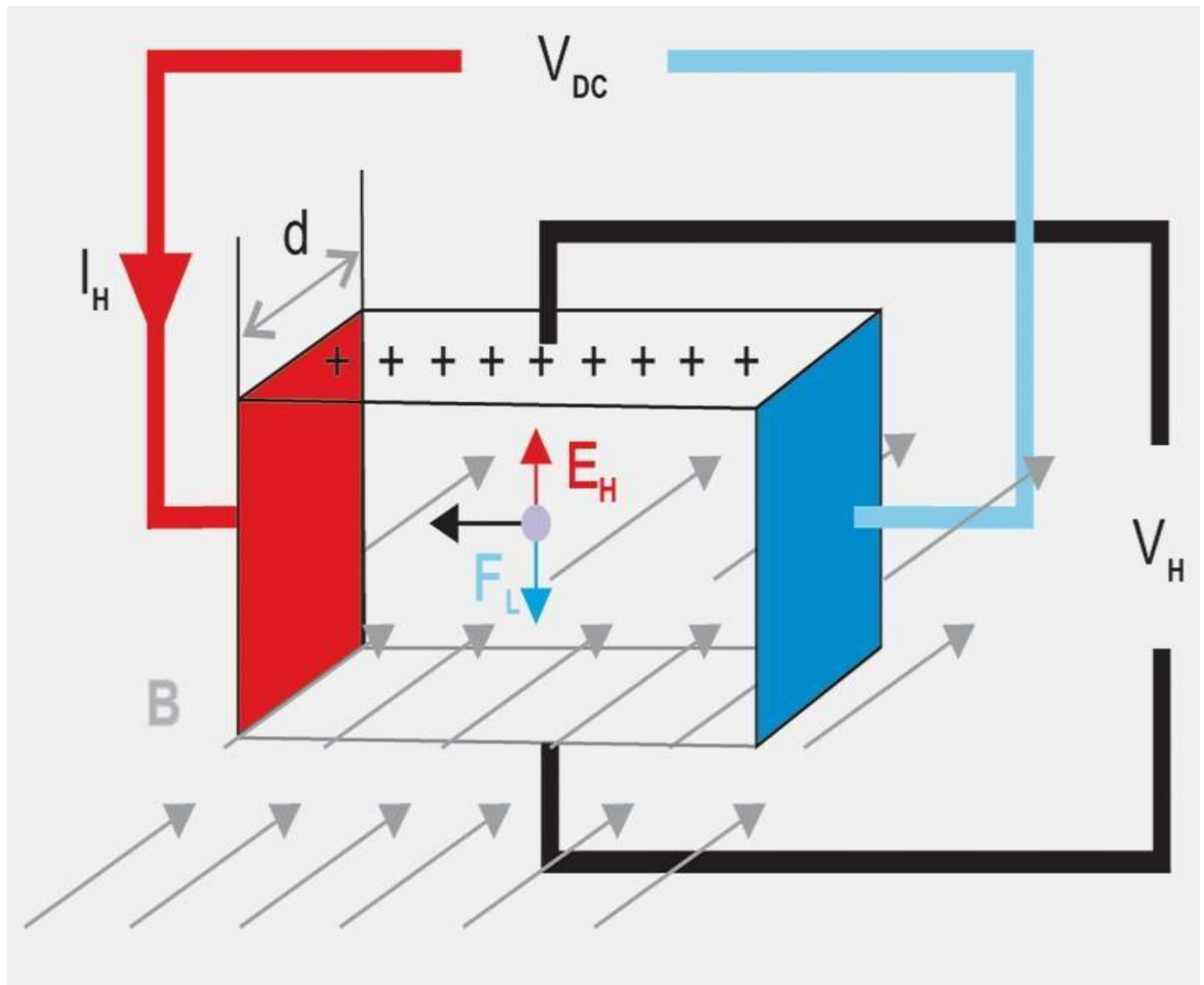

- Let us consider a n-type semiconductor. Let v be the velocity of the electron flowing right to left just opposite to the conventional flow of current and magnetic field is applied perpendicular to the flow of current. Then, the electron experiences a force of ' Bev ' due to magnetic field which is perpendicular to both ' B ' and flow of current.
- Thus electron is deflected causing a negative charge to accumulate on one face of the slab. A potential difference is therefore established between faces and gives rise to a force eE_H on electron in opposite direction. At equilibrium,

$$eE_H = Bev$$

$$E_H = Bv$$



APPLICATIONS:

Determination of type of semiconductor:

- For, n-type field is developed in negative direction compared to p-type. Therefore,

For n-type,

$$R_H = -\frac{1}{ne}$$

For p-type,

$$R_H = \frac{1}{pe}$$



Determination of hall coefficient:

- If 'b' is width of sample across which hall voltage V_H is measured. Then

$$V_H = E_H b$$

- Since,

$$E_H = B J R_H$$

- Therefore,

$$V_H = R_H B b J$$

- If 't' is thickness of sample, then current density,

$$J = \frac{I}{A} = \frac{I}{bt}$$

$$V_H = R_H B b \times \frac{I}{bt}$$

$$R_H = \frac{V_H t}{B I}$$



Determination of mobility:

- For n-type material,

$$\sigma_n = ne\mu_e$$

$$\mu_e = \frac{\sigma_n}{ne}$$

$$\mu_e = R_H \sigma_n$$

- For p-type material,

$$\mu_h = R_H \sigma_p$$



Determination of carrier concentration:

Once Hall coefficient is measured, the carrier concentration n can be obtained from

$$n = \frac{1}{eR_H}$$



P-N JUNCTION:

- When a layer of p-type semiconductor material is placed on the layer of n-type semiconductor material in such a way that the atoms of p-type combine with the atoms of n-type across the surface contact.
- Such a surface junction where combination has occurred is known as P-N junction.
- In practice, a PN junction is obtained in three ways.
 - Grown junction type
 - Fused or alloyed junction type
 - Diffused junction type



- **Grown junction type:**

Grown junctions are formed when donor impurities are introduced into one side and acceptor impurities into the other side of a single crystal at the time of crystal growing from a melt of silicon or germanium.

- **Alloy junction type:**

In this type, p-type and n-type materials are kept in contact and fused together properly by heat treatment to form junction.

- **Diffused junction type:**

In this process, a p-type impurity is painted into n-type substrate and both are heated. Now impurity atoms diffuse into n-type substrate for a short distance and form p-n junction.



- The formation of p-n junction is shown below. When the p-type and n-type are joined, in the region of contact the free electrons diffuse from n-region and combine with holes in p-region. This leaves n-region near the boundary positively charged and p-region negatively.

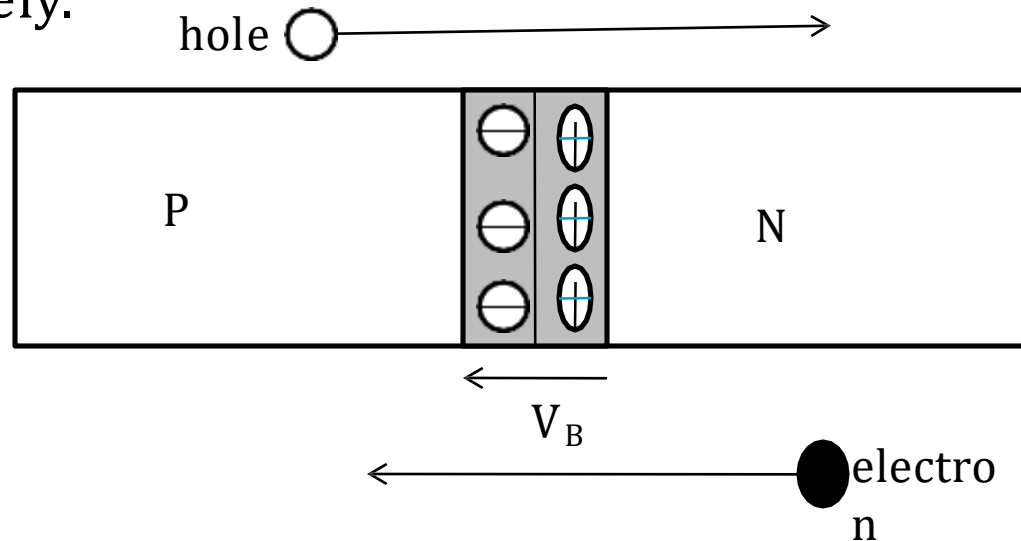

- As a result, electric field appears in small region on either side of junction. This region is called depletion region. Due to this electric field, potential difference appears across the region and this potential is called contact potential or barrier potential or junction barrier.



ENERGY DIAGRAM OF PN JUNCTION:

- The energy level diagrams of p-type and n-type materials are as follows.

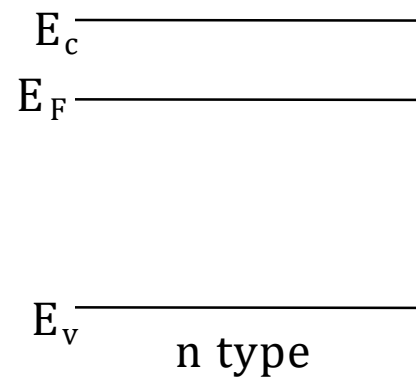
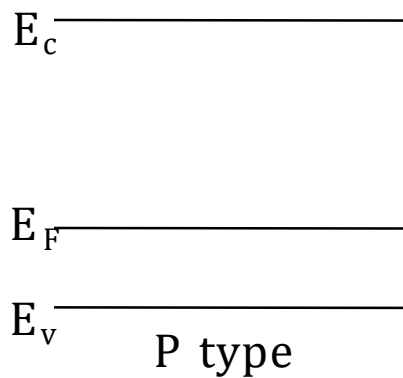

- For p-type the fermi energy level lies nearer to valence level(E_v) as holes conc. is more in VB
- Similarly for n-type, fermi energy level lies nearer to conduction level(E_c) as electron conc. is more in CB



HEN JUNCTION IS FORMED THE ERMI LEVELS BECOME COMMON FOR BOTH THE TYPES.

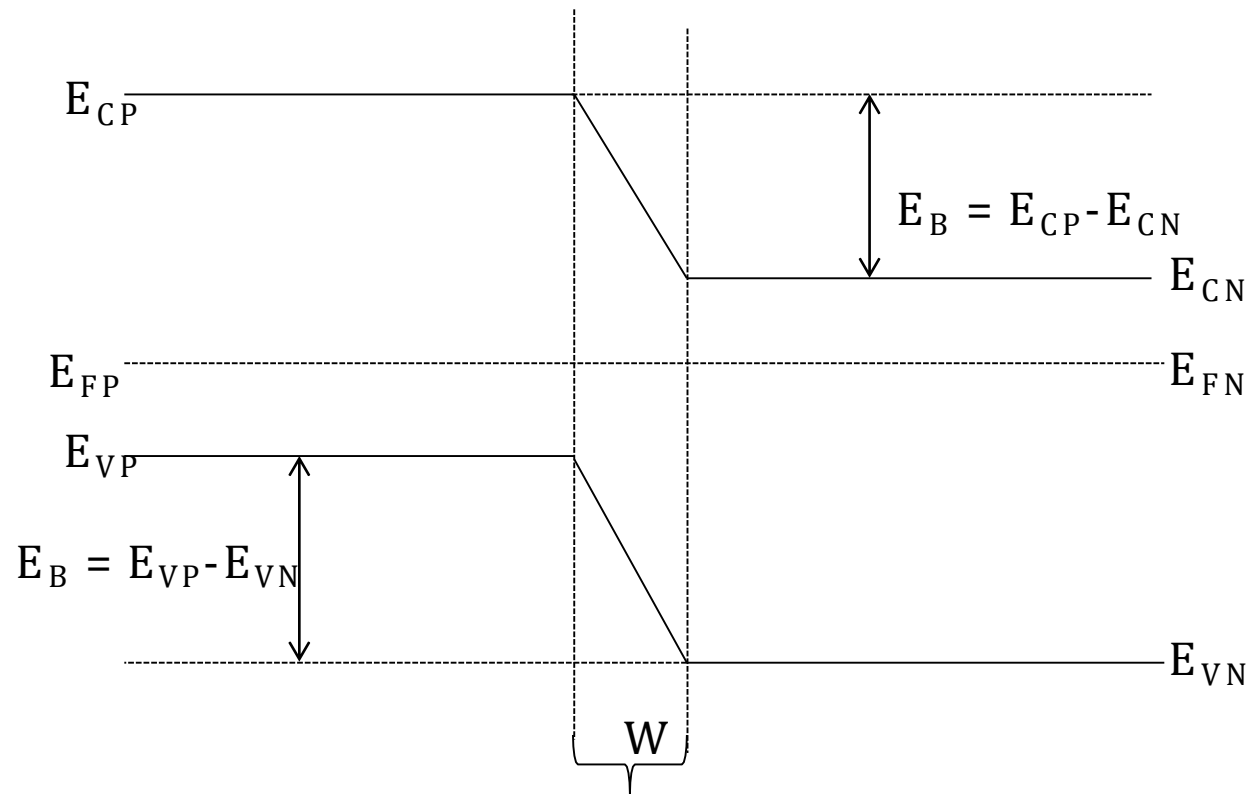

- The contact potential across the junction is due to the potentials of depletion regions on n-side and p-side is

$$V_B = V_n - V_p$$

- Under unbiased condition, no net current flow at equilibrium. The electric field E_B across the junction is given by

$$E_B = E_{vp} - E_{vn} = E_{cp} - E_{cn} = eV_B = e(V_n - V_p)$$

- When two electrodes are taken from the p type and n-type materials of the p-n junction, then it is called p-n junction diode.

- Symbol is as shown

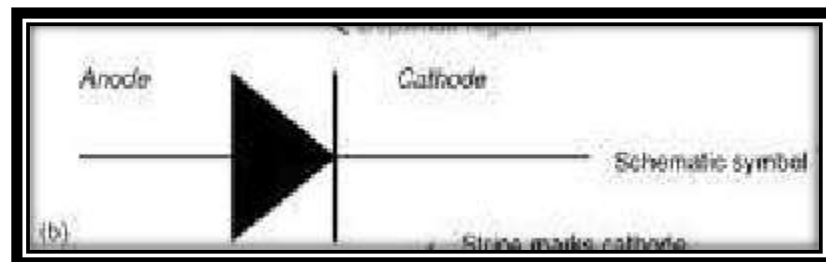

BIASING OF P-N JUNCTION DIODE:

- Unbiasing: When the PN junction is unbiased, it is in equilibrium and contact potential appears across the region.

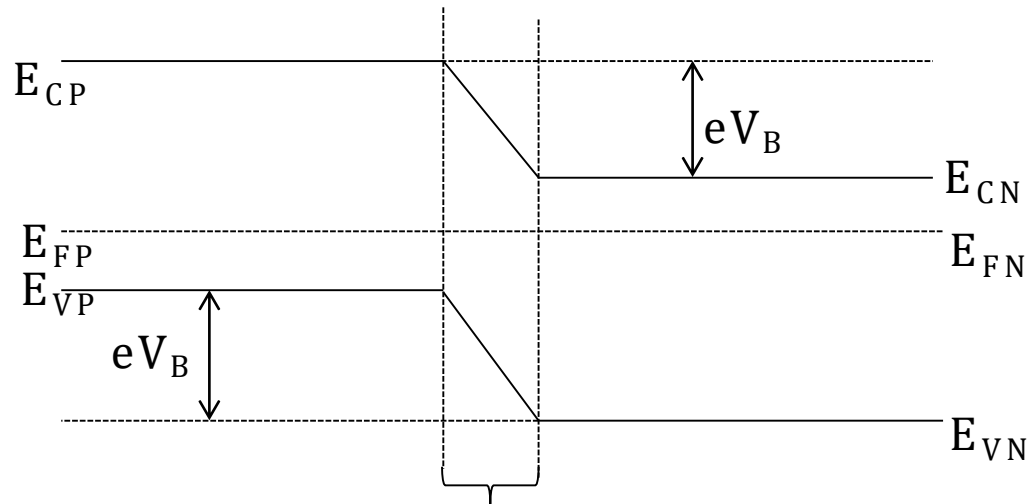
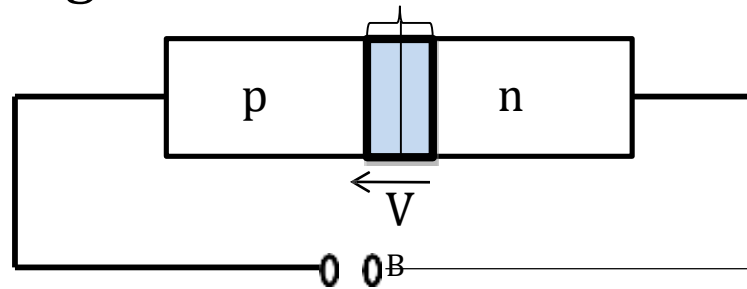

- **Forward biasing:** When the positive of the source is connected to the p-side and negative of the source is connected to the n-side, then the junction is said to be forward biased.
 - This voltage V_F appears across the depletion region. Since, V_B acts from n to p, the electrostatic potential barrier is lowered and is given by $V_B - V_F$.
 - The electric field in the transition region reduces.
 - The width of transition region decreases.
 - Hence in forward biasing p-n junction offers less resistance

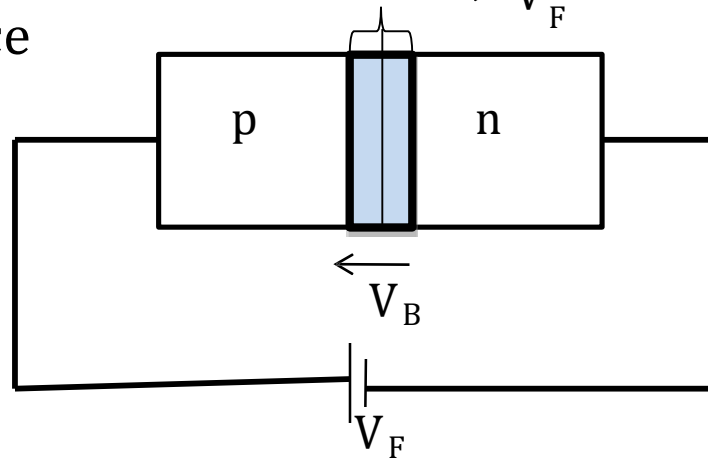

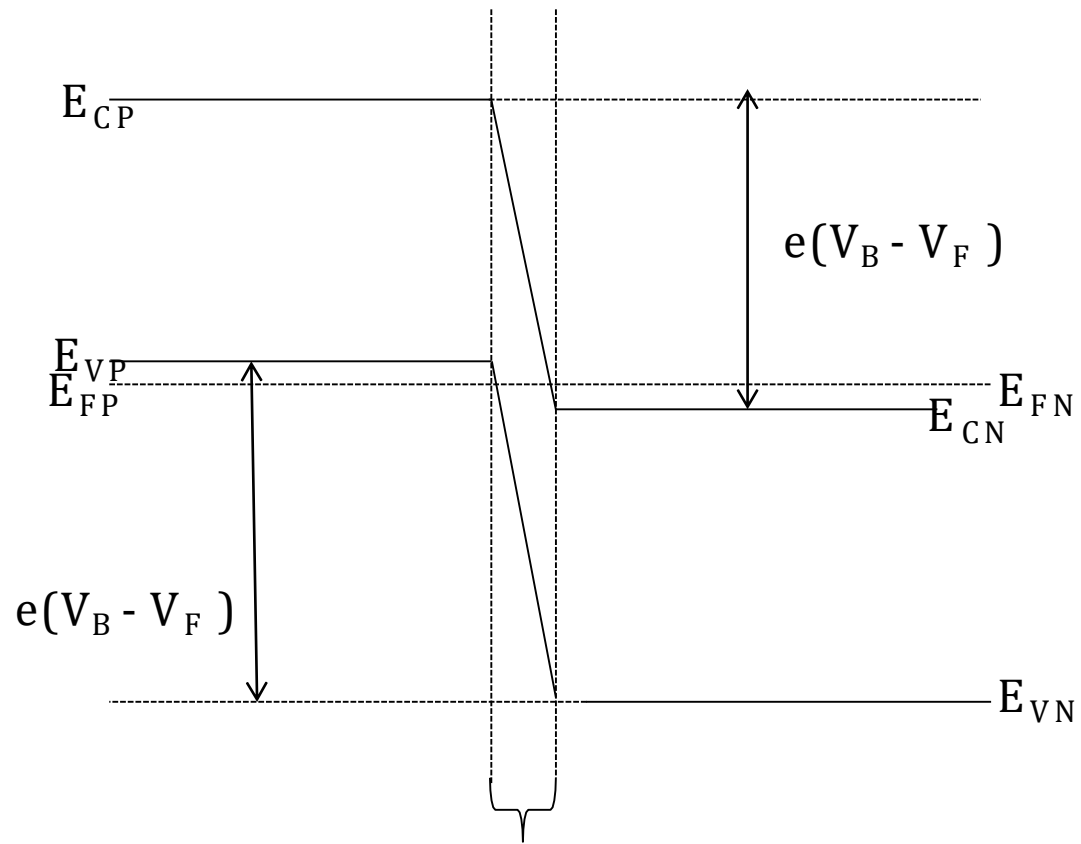

- **Reverse biasing:** When the positive of the source is connected to the n-side and negative of the source is connected to the p-side, then the junction is said to be forward biased.
 - This voltage V_R appears across the depletion region. Since, V_B acts from n to p, the electrostatic potential barrier is increased and is given by $V_B + V_R$.
 - The electric field in the transition region increases.
 - The width of transition region increases.
 - Hence in reverse biasing p-n junction offers high resistance

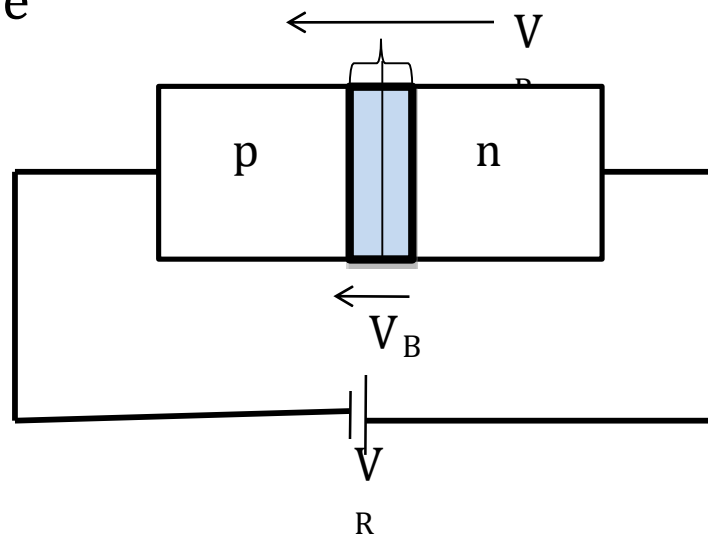

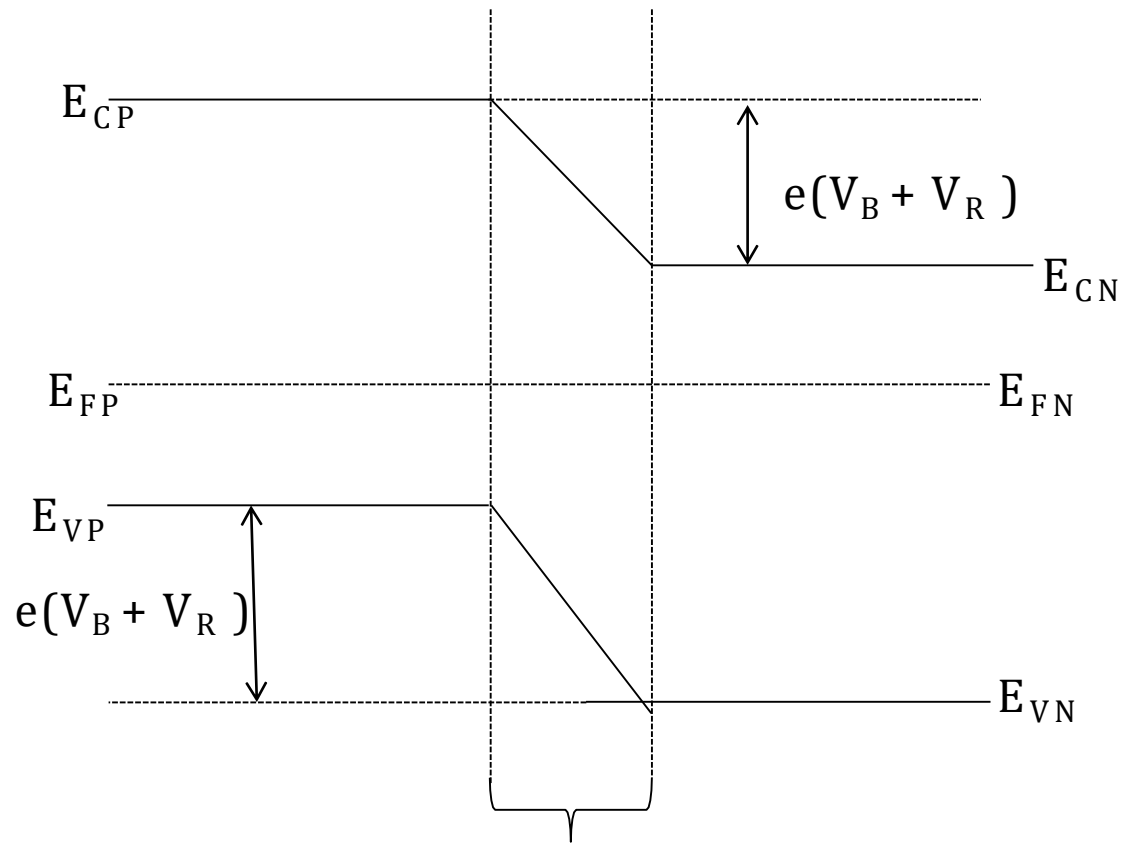

V-I CHARACTERISTICS OF P-N JUNCTION

Unbiased Circuit:

when the junction is not connected to any voltage source, it is said to be unbiased and due to barrier potential across the junction, there is no flow of charge carriers and hence no current flow through the junction.

Forward biased circuit:

when the diode is forward biased, since the potential barrier height is very small, when the applied voltage exceeds that value, the junction resistance becomes almost zero. Hence, for small increase of applied voltage, large increase in circuit current is observed. The current is called forward current. Under forward bias, the d.c resistance is around 100 ohms for germanium diode.



Reverse biased circuit:-

When the diode is reverse biased, a slight reverse current (in μA) flows in the circuit. Even for a large increase in bias voltage, there is a negligible increase in current. When the applied reverse voltage is high enough to break the covalent bonds of the crystal, the current rises suddenly. This voltage is called breakdown voltage or reverse voltage. For Ge diode reverse resistance is around $1\text{M}\Omega$.



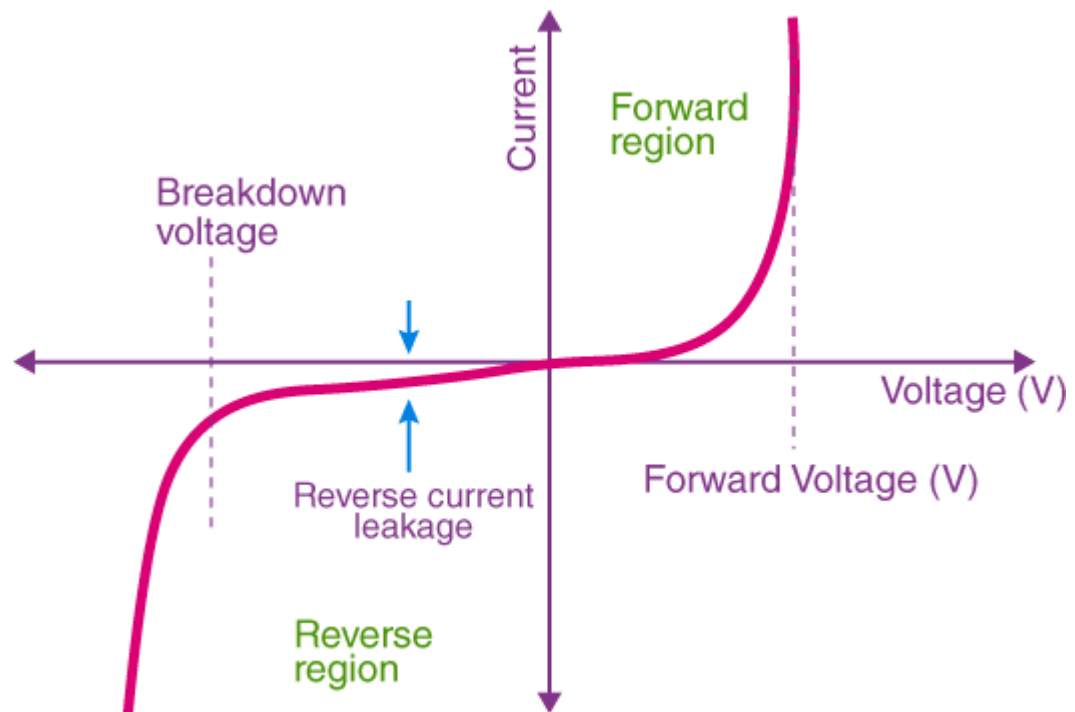

ZENER DIODE

- A Zener diode is a **silicon semiconductor device that permits current to flow in either a forward or reverse direction.** The diode consists of a special, heavily doped p-n junction, designed to conduct in the reverse direction when a certain specified voltage is reached.



ZENER EFFECT

- When the voltage across the terminals of a Zener diode is reversed and the potential reaches the Zener Voltage (knee voltage), the junction breaks down and the current flows in the reverse direction. This effect is known as the Zener Effect.



WORKING:

- A Zener diode operates just like a normal diode when it is forward-biased.
- However, a small leakage current flows through the diode when connected in reverse biased mode.
- As the reverse voltage increases to the predetermined breakdown voltage (V_z), current starts flowing through the diode.
- The current increases to a maximum, which is determined by the series resistor, after which it stabilizes and remains constant over a wide range of applied voltage.
- **There are two types of breakdowns for a Zener Diode:**
 - Avalanche Breakdown
 - Zener Breakdown



AVALANCHE BREAKDOWN IN ZENER DIODE

- Avalanche breakdown occurs in normal diode and Zener Diode at high reverse voltage.
- When a high value of reverse voltage is applied to the PN junction, the free electrons gain sufficient energy and accelerate at high velocities.
- These free electrons moving at high velocity collide with other atoms and knock off more electrons.
- Due to this continuous collision, a large number of free electrons are generated as a result of electric current in the diode rapidly increases.
- This sudden increase in electric current may permanently destroy the normal diode.
- However, a Zener diode is designed to operate under avalanche breakdown and can sustain the sudden spike of current.
- Avalanche breakdown occurs in Zener diodes with Zener voltage (V_z) greater than 6V.



ZENER BREAKDOWN IN ZENER DIODE

- When the applied reverse bias voltage reaches closer to the Zener voltage, the electric field in the depletion region gets strong enough to pull electrons from their valence band.
- The valence electrons that gain sufficient energy from the strong electric field of the depletion region break free from the parent atom.
- At the Zener breakdown region, a small increase in the voltage results in the rapid increase of the electric current.



CIRCUIT SYMBOL OF ZENER DIODE

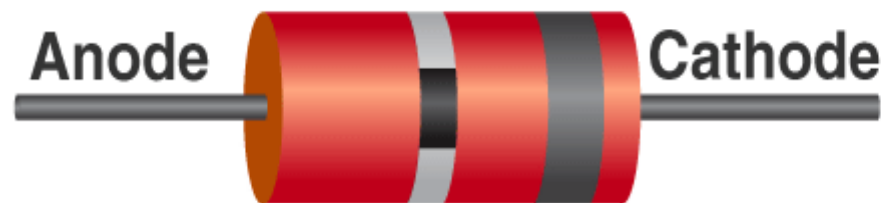
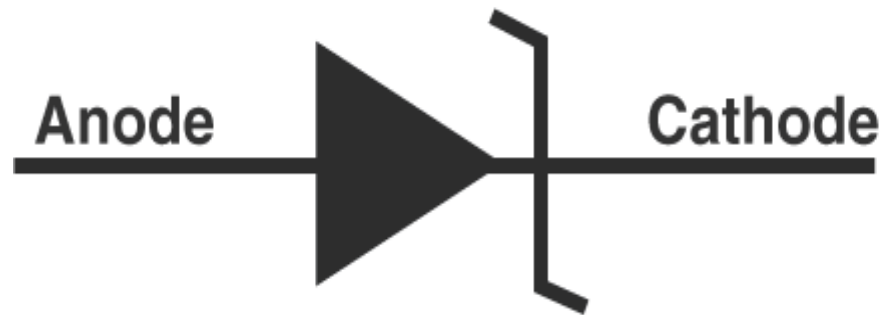

(Zener diode)



V-I CHARACTERISTICS OF ZENER DIODE

- The V-I characteristics of a Zener diode can be divided into two parts as follows:
 - (i) Forward Characteristics**
 - (ii) Reverse Characteristics**

Forward Characteristics of Zener Diode

- The first quadrant in the graph represents the forward characteristics of a Zener diode. From the graph, we understand that it is almost identical to the forward characteristics of any other P-N junction diode.

Reverse Characteristics of Zener Diode

- When a reverse voltage is applied to a Zener diode, a small reverse saturation current I_0 flows across the diode.
- This current is due to thermally generated minority carriers. As the reverse voltage increases, at a certain value of reverse voltage, the reverse current increases drastically and sharply.
- This is an indication that the breakdown has occurred. We call this voltage breakdown voltage or Zener voltage, and V_z denotes it.



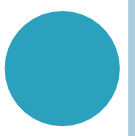
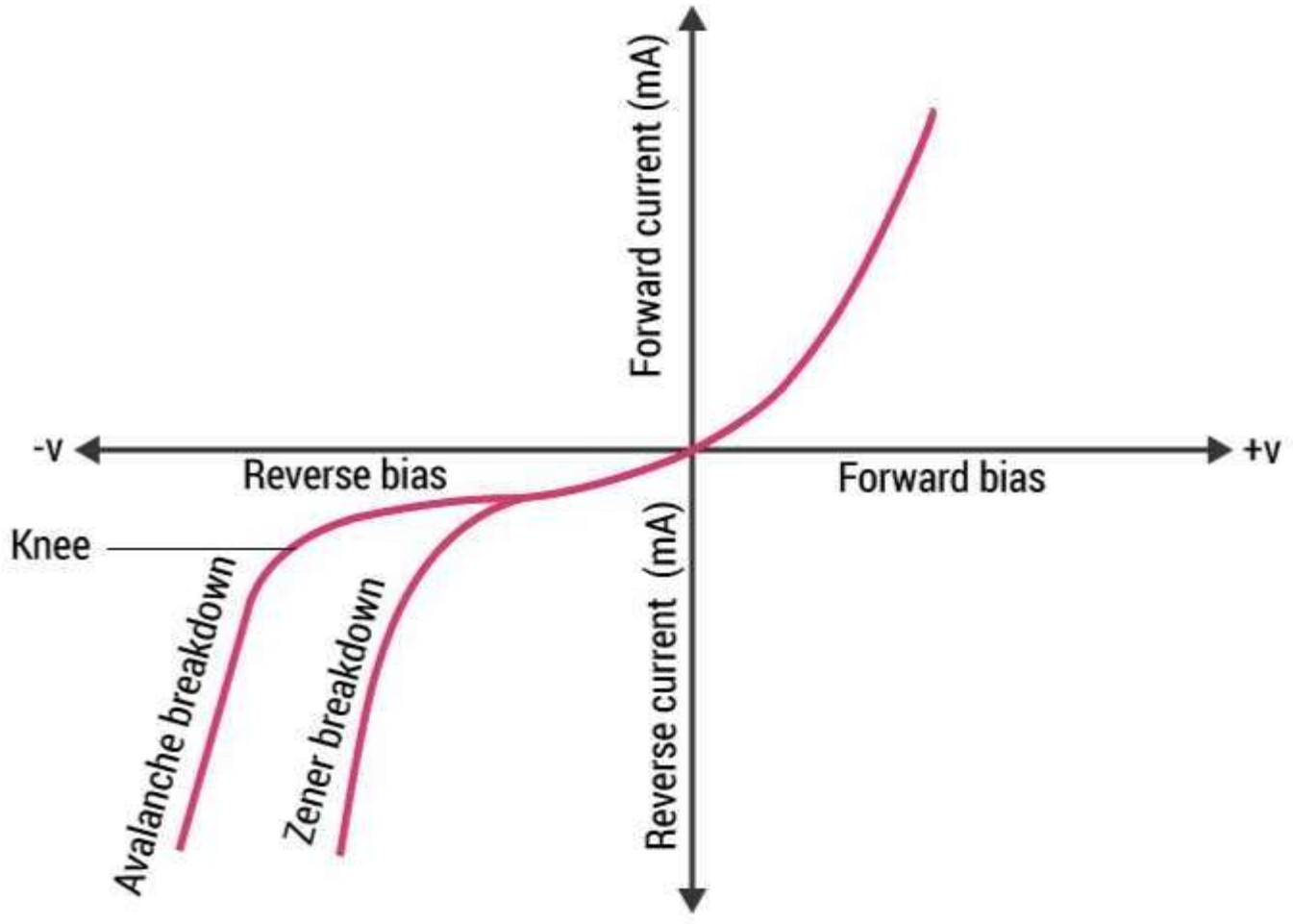

APPLICATION OF ZENER DIODE

Zener diode as a voltage regulator:

- Zener diode is used as a Shunt voltage regulator for regulating voltage across small loads.
- The Zener diode is connected parallel to the load to make it reverse bias, and once the Zener diode exceeds knee voltage, the voltage across the load will become constant.
- The breakdown voltage of Zener diodes will be constant for a wide range of currents.



APPLICATIONS:

Zener diode in over-voltage protection:

- When the input voltage is higher than the Zener breakage voltage, the voltage across the resistor drops resulting in a short circuit, this can be avoided by using the Zener diode.

Zener diode in clipping circuits:

- Zener diode is used for modifying AC waveform clipping circuits by limiting the parts of either one or both the half cycles of an AC waveform.



CARRIER GENERATION:

- Carrier generation is a process where electron-hole pairs are created by exciting an electron from the valence band of the semiconductor to the conduction band, thereby creating a hole in the valence band.

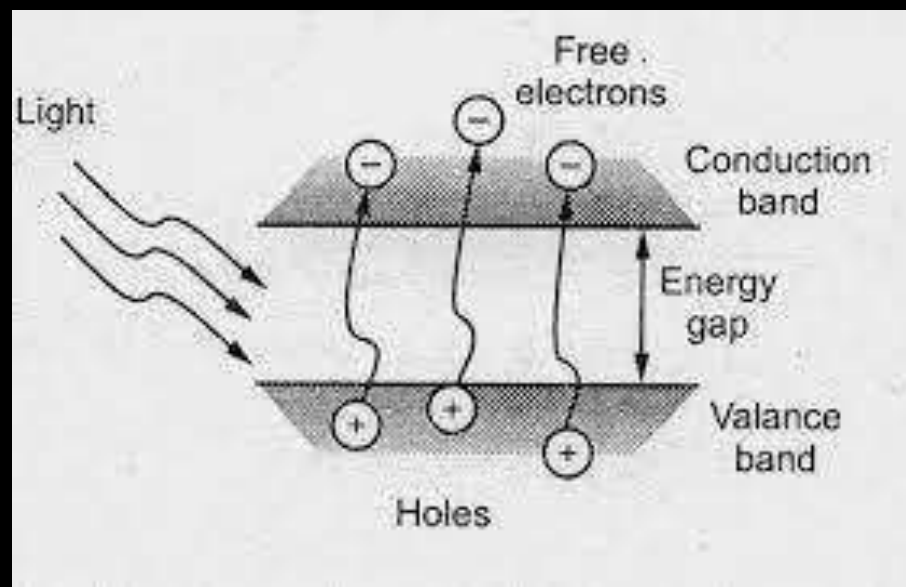

RECOMBINATION OF CARRIERS:

- Any electron which exists in the conduction band is in a meta-stable state and will eventually fall back to a lower energy position in the valence band filling a hole in the valence band.
- Due to de-excitation of electrons to lower levels there by producing or emitting extra energy in the form of radiations.
- There are two types recombinations.
 - Radiative recombination
 - Non radiative recombination.
- Again non radiative recombination is of two types
 - Auger recombination and
 - Trap assisted recombination



Radioative recombination:

- It is the recombination mechanism that dominates in direct band gap semiconductors.
- A direct band gap semiconductors is one in which the maximum energy level of valence band aligns with the minimum energy of the conduction band.
- In this process when the electron moves from its conduction band in to the empty valence band state associated with a the energy is released in the form of radiations.
- Depending on the material chosen, the out put radiation will be either light or heat energy.

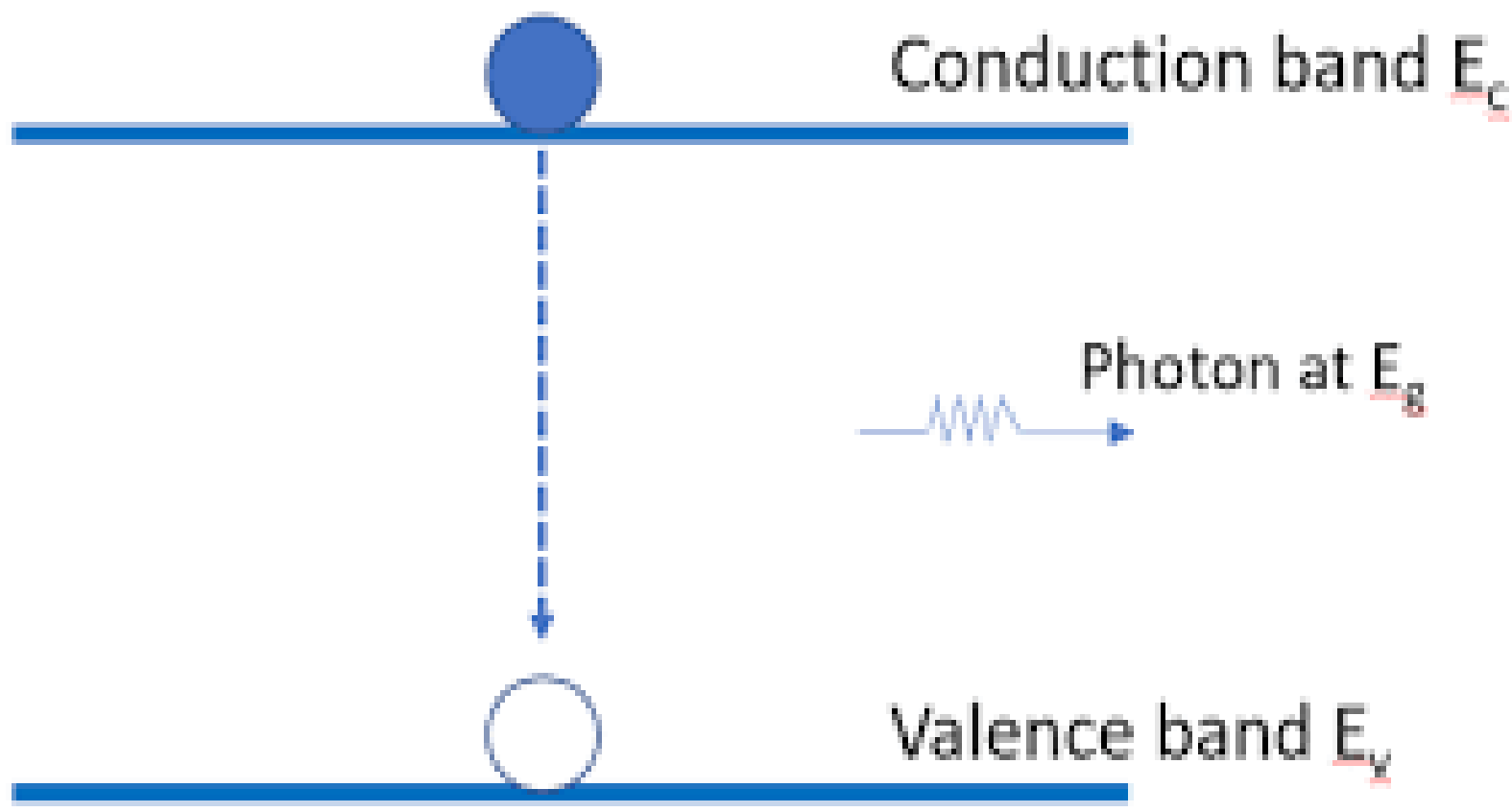

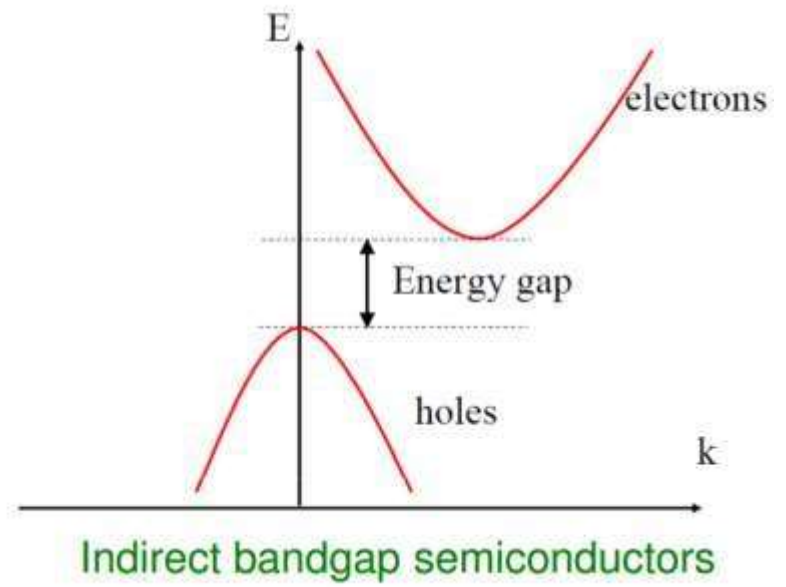
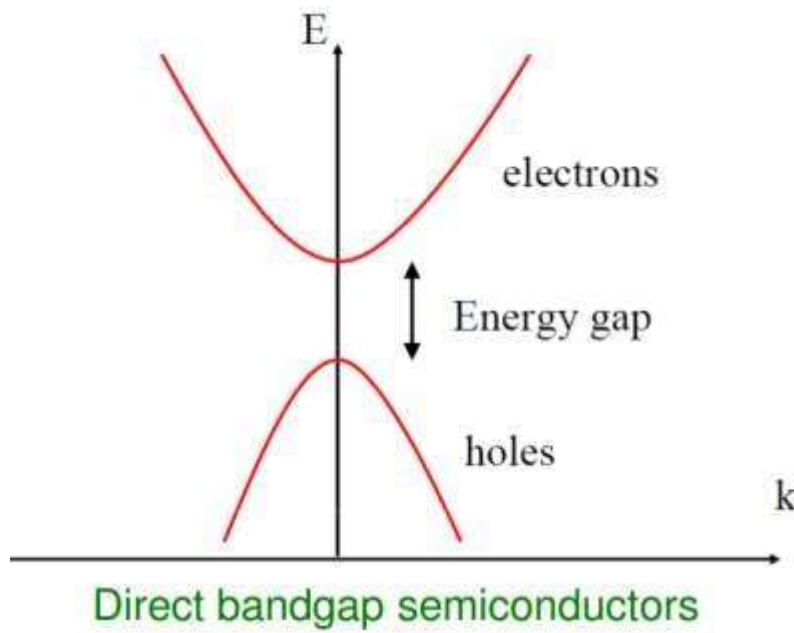

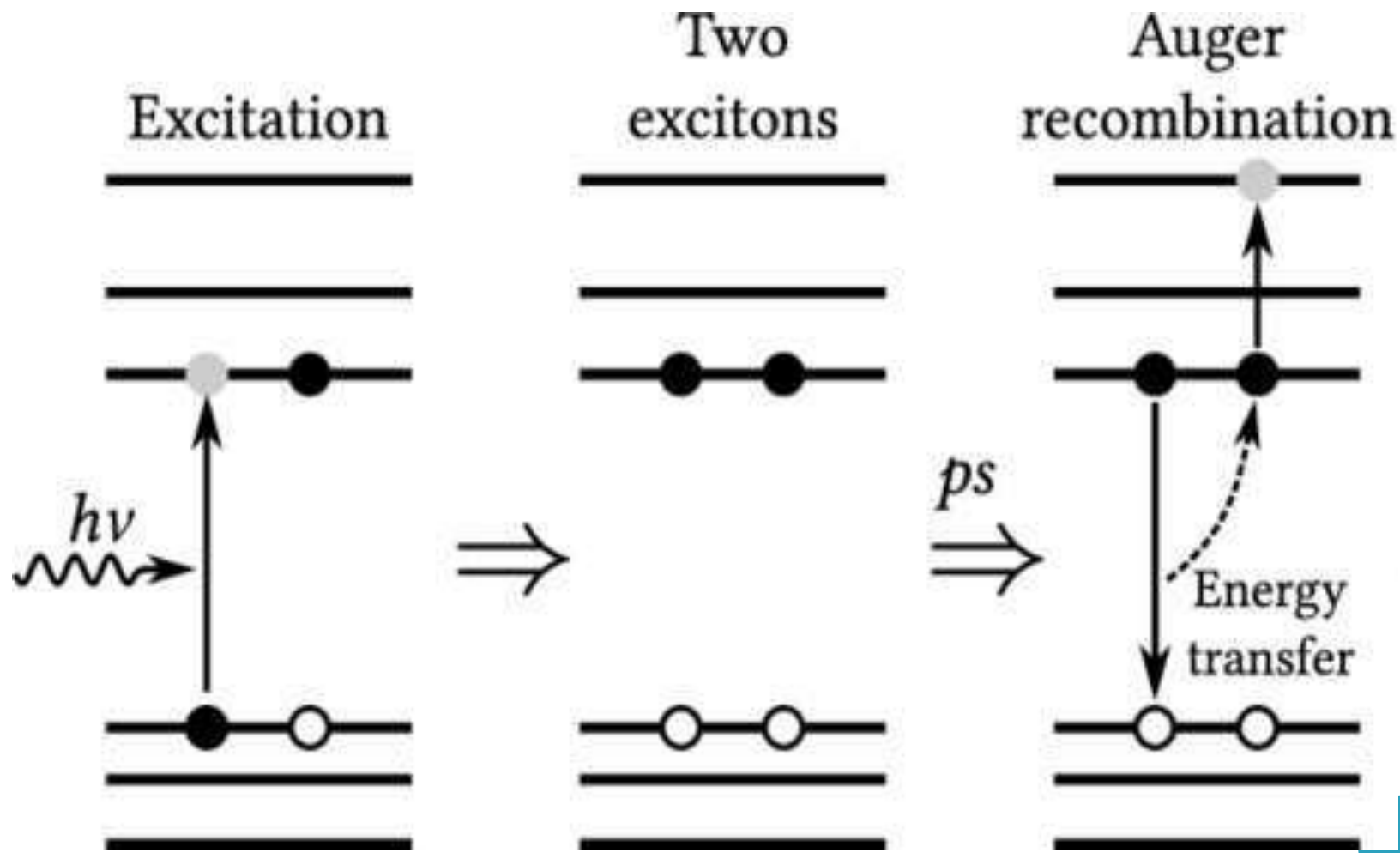

LED (LIGHT EMITTING DIODE)

- LED is an optical semiconductor device that converts electrical energy into light energy.
- Light Emitting Diodes (LEDs) are the most widely used semiconductor diodes among all the different types of semiconductor diodes available today.
- Light emitting diodes emit either visible light or invisible infrared light when forward biased. The LEDs which emit invisible infrared light are used for remote controls.



SYMBOL

- The symbol of LED is similar to the normal p-n junction diode except that it contains arrows pointing away from the diode indicating that light is being emitted by the diode.

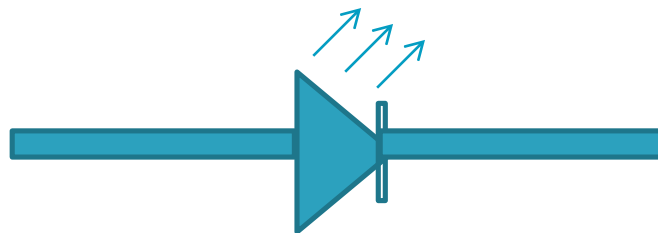

LED CONSTRUCTION

- One of the methods used to construct LED is to deposit three semiconductor layers on the substrate.
- The three semiconductor layers deposited on the substrate are n-type semiconductor, p-type semiconductor and active region.
- Active region is present in between the n-type and p-type semiconductor layers.



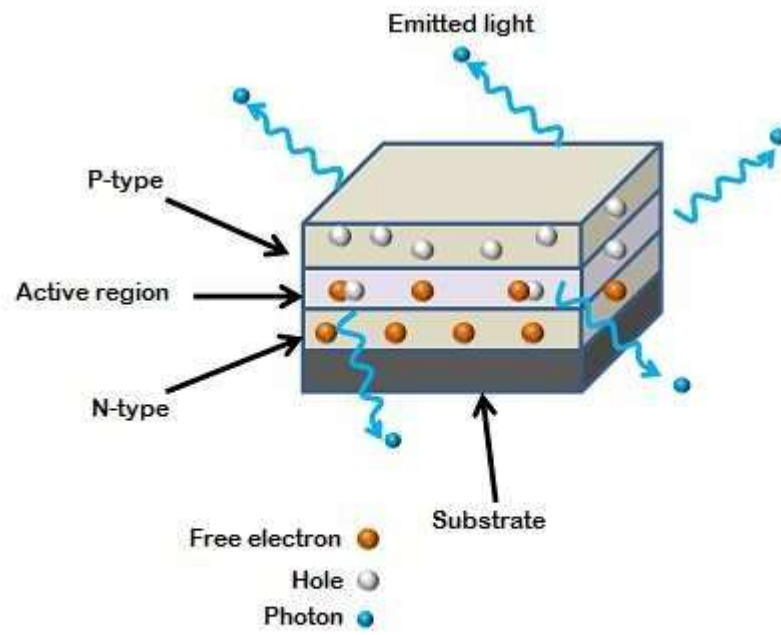

Construction of LED

Physics and Radio-Electronics



WORKING

- When LED is forward biased, free electrons from n-type semiconductor and holes from p-type semiconductor are pushed towards the active region.
- When free electrons from n-side and holes from p-side recombine with the opposite charge carriers (free electrons with holes or holes with free electrons) in active region, an invisible or visible light is emitted.
- In LED, most of the charge carriers recombine at active region. Therefore, most of the light is emitted by the active region. The active region is also called as depletion region.



ENERGY BAND DIAGRAM

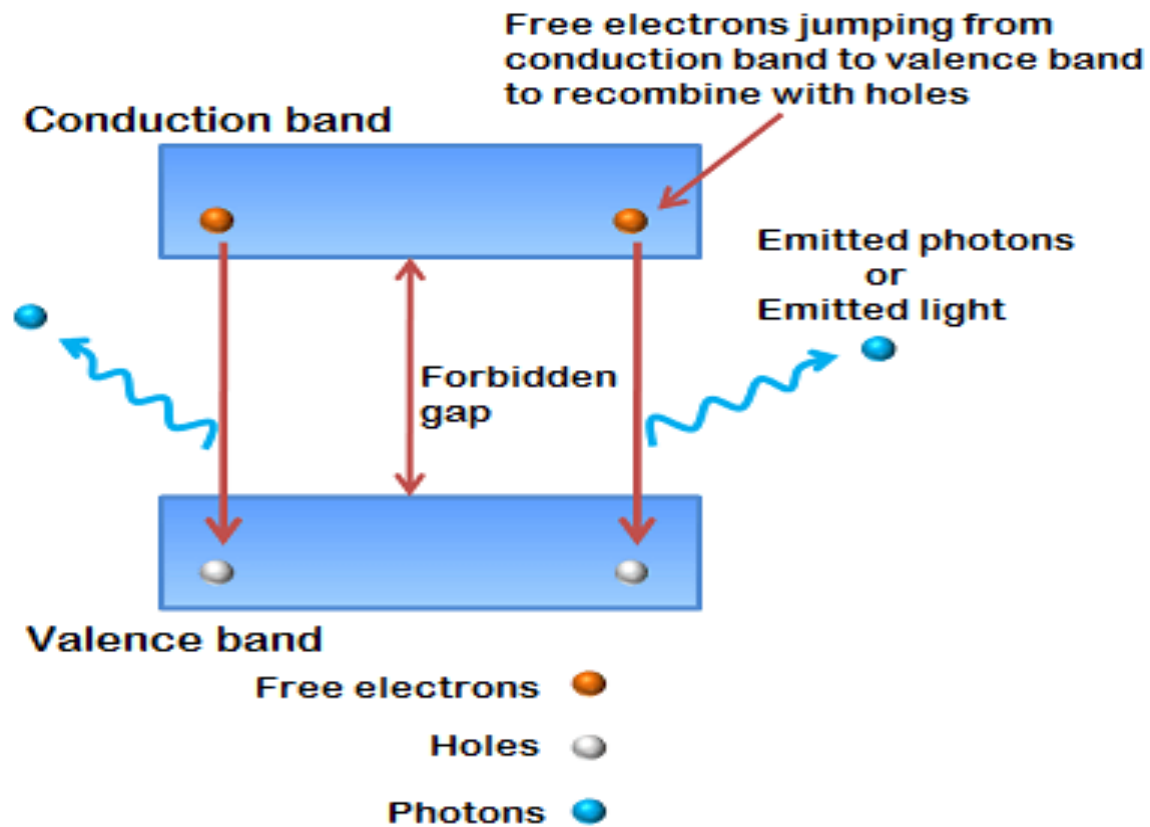

Process of light emission in LED



- The current flowing through the LED is mathematically written as

$$I_F = \frac{V_s - V_D}{R_s}$$

Where,

I_F = Forward current

V_s = Source voltage or supply voltage

V_D = Voltage drop across LED

R_s = Resistor or current limiting resistor

- Voltage drop is the amount of voltage wasted to overcome the depletion region barrier (which leads to electric current flow).



OUTPUT CHARACTERISTICS OF LED

- The amount of output light emitted by the LED is directly proportional to the amount of forward current flowing through the LED. More the forward current, the greater is the emitted output light. The graph of forward current vs output light is shown in the figure.

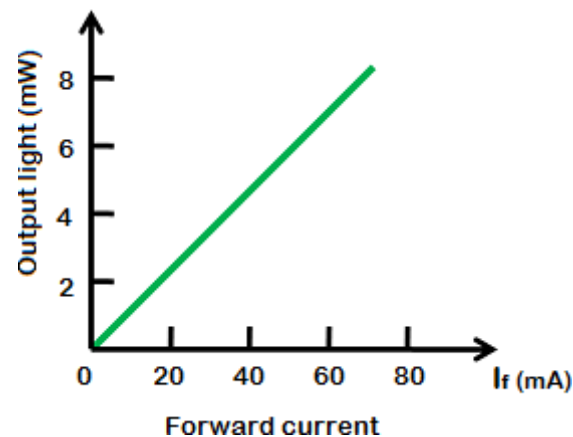

TYPES OF LED'S

- LEDs are mainly classified into two types: visible LEDs and invisible LEDs.
- Visible LED is a type of LED that emits visible light. These LEDs are mainly used for display or illumination where LEDs are used individually without photosensors.
- Invisible LED is a type of LED that emits invisible light (infrared light). These LEDs are mainly used with photosensors such as photodiodes.



MATERIALS USED

- The material used for constructing LED determines its color. In other words, the wavelength or color of the emitted light depends on the forbidden gap or energy gap of the material.
 - Different materials emit different colors of light.
 - Gallium arsenide LEDs emit red and infrared light.
 - Gallium nitride LEDs emit bright blue light.
 - Yttrium aluminium garnet LEDs emit white light.
 - Gallium phosphide LEDs emit red, yellow and green light.
 - Aluminium gallium nitride LEDs emit ultraviolet light.
- 

ADVANTAGES OF LED OR FIGURE OF MERIT

- The brightness of light emitted by LED is depends on the current flowing through the LED. Hence, the brightness of LED can be easily controlled by varying the current. This makes possible to operate LED displays under different ambient lighting conditions.
- Light emitting diodes consume low energy.
- LEDs are very cheap and readily available.
- LEDs are light in weight.
- Smaller size.
- LEDs have longer lifetime.
- LEDs operates very fast. They can be turned on and off in very less time.
- LEDs do not contain toxic material like mercury which is used in fluorescent lamps.
- LEDs can emit different colors of light.



Disadvantages of LED

- LEDs need more power to operate than normal p-n junction diodes.
- Luminous efficiency of LEDs is low.

Applications of LED

- The various applications of LEDs are as follows
- Burglar alarms systems
- Calculators
- Picture phones
- Traffic signals
- Digital computers
- Multimeters
- Microprocessors
- Digital watches
- Automotive heat lamps
- Camera flashes
- Aviation lighting



SEMICONDUCTOR LASER DIODE

- The semiconductor laser is also called as diode laser.
- It has very important application in fibre optic communication.
- The wave length of the emitted light depends up on the band gap of the material.

$$\lambda = \frac{hc}{E_g} = \frac{1.24}{E_g} \mu m$$

- If p and n-type materials are prepared from the same material then the p-n junction is called as homojunction semiconductor laser source.
- If p and n type materials are prepared from different materials then they are called as hetro junction semiconductor laser source.



PRINCIPLE:

when a p-n junction diode is forward biased, at junction holes and electrons recombination occurs. Due to recombination photon are emitted. This emitted photons stimulate further recombination and hence a laser output is obtained.



HOMO-JUNCTION SEMICONDUCTOR LASER DIODE

Construction:

- GaAs crystal which is heavily doped with suitable dopants to form a p-n junction.
- At the junction the sides through which emitted light is coming out are well polished and parallel to each other.
- Two metal contacts are taken , one from the p-type and other from the n-type which acts like a cathode and a anode.
- Since the p and n-type materials are prepared from the same material,the p-n junction is called as homojunction semiconductor laser source



- The basic mechanism responsible for light emission from a semiconductor is the recombination of electrons and holes at p-n junction when a current is passed through the diode.

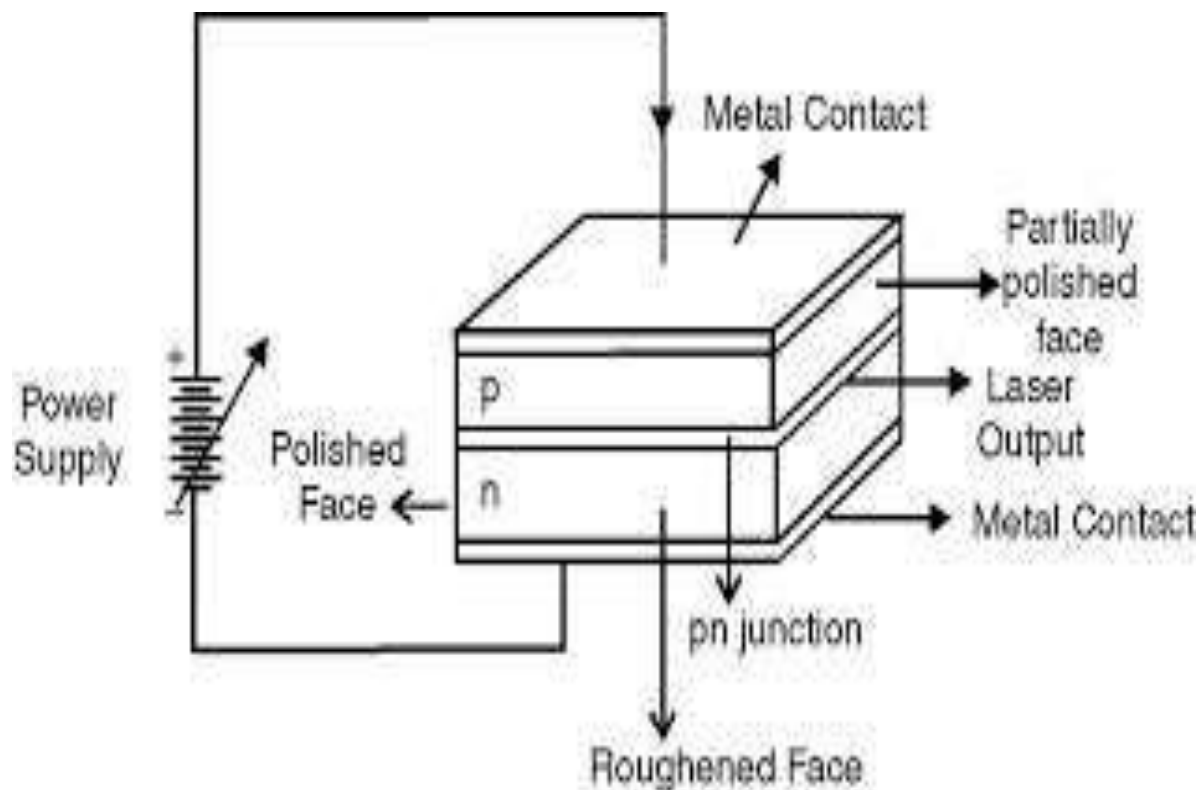

WORKING

- When a current is passed through a p-n junction, holes are injected from p-region into n-region and electrons are injected from n-region into p-region as junction is forward biased.
- The electrons are minority charge carriers in p-side and holes are minority charge carriers in n-side.
- The excess minority charge carriers recombine with majority charge carriers of n and p material, resulting in the release of photons.
- Further emitted photons increase the recombination rate.
- Only pulsed output is obtained. This drawback is overcome in hetero junction laser structure. For example Ga Al As.



ENERGY LEVEL DIAGRAM:

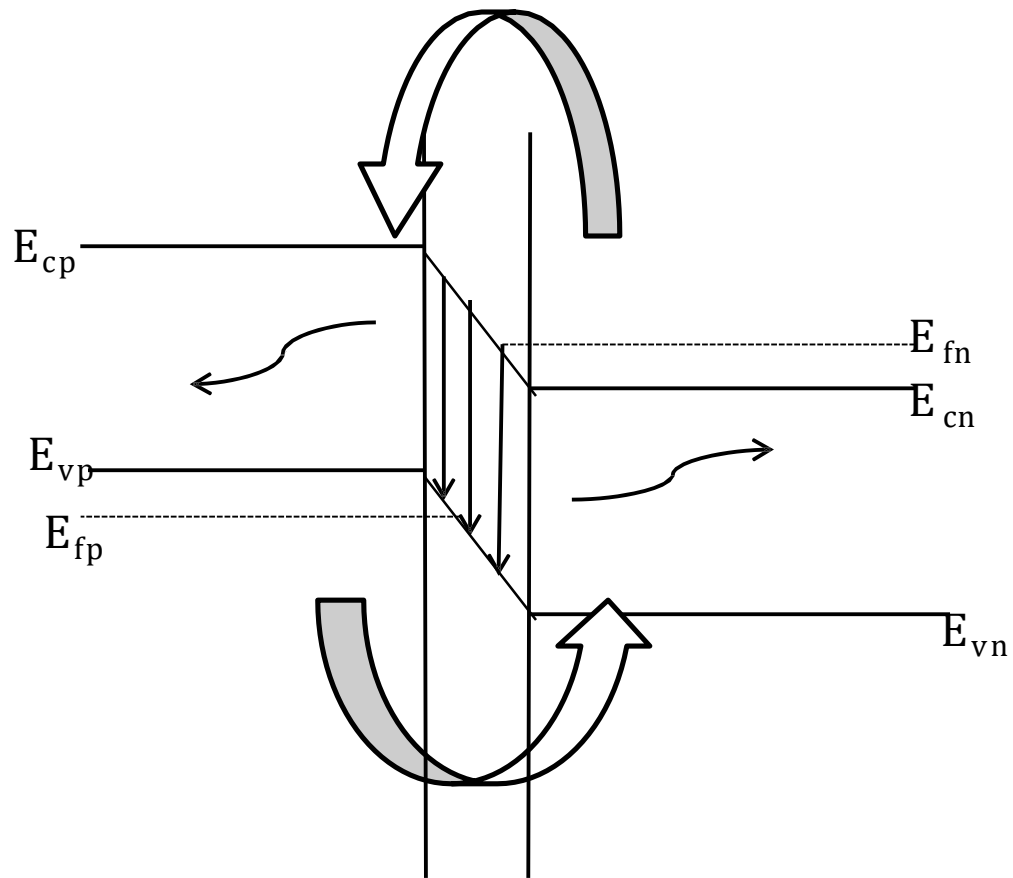

CHARACTERISTICS:

- The characteristics are drawn between output current and output light intensity.
- Below the threshold current, the output is due to minority charge carrier recombination.
- Further emitted photons increase the recombination rate, current increases sharply after the threshold current, hence the light output also.

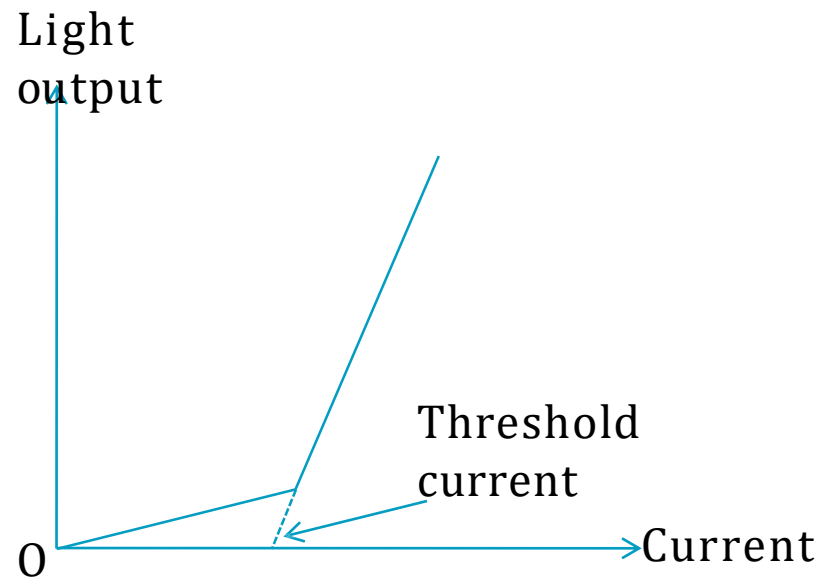

FIGURE OF MERITS

- Semiconductor lasers are cheapest and smallest lasers available
- Semiconductor lasers are Massey produced and easily fabricated
- The laser output can be easily modulated
- Highly efficient



Disadvantages:

1. It is very difficult to grow different layers of PN junction.
2. The cost is very high.



APPLICATIONS OF LASER DIODE

- Fibre optic communication
- Metal cutting
- Welding
- Lasers are widely used in electronic industry in trimming the components of ICs.
- Lasers are used to destroy kidney stones and gall stones. The laser pulses break the stones into small pieces.
- Lasers are used in cancer diagnosis and therapy.
- Lasers are used in blood loss less surgery



PIN DIODE:

Construction:

- The PIN diode has three layers such as
 - P-type layer
 - Intrinsic layer
 - N-type layer
- PIN diode is formed by sandwiching intrinsic layer between p-type and n-type semiconductor to create an electric field between them.



- The P and N regions are there and the region between them consists of the intrinsic material and the doping level is said to be very low in this region.
- The thickness of the intrinsic layer is very narrow, which ranges from 10 – 200 microns. The P region and the N-type regions are known to be heavily doped.
- The changes in the properties of the diode are known from the intrinsic material.
- These diodes are made of silicon.
- The intrinsic region of the PIN diode acts like an inferior rectifier which is used in various devices such as attenuators, photodetectors, fast switches, high voltage power circuits, etc.



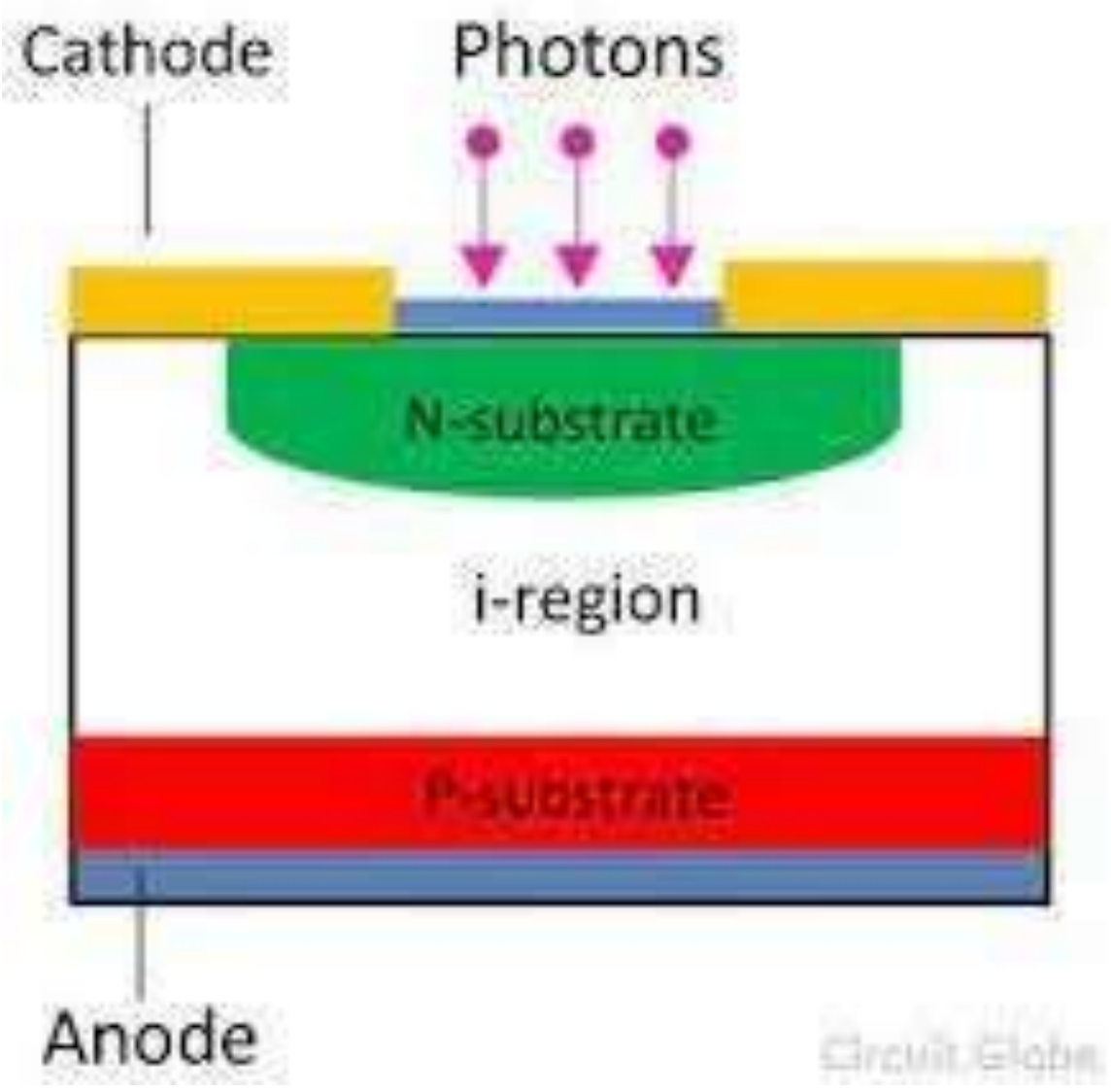

WORKING:

- The PIN diode is operated in photo conductive mode, where a reverse bias is applied.
- When light falls on the detector, photons with proper energy create electron-hole pairs in this region by raising an electron from valence band to conduction band, leaving a hole behind. These carriers drift quickly away from junction creating current which is proportional to intensity of incident light.



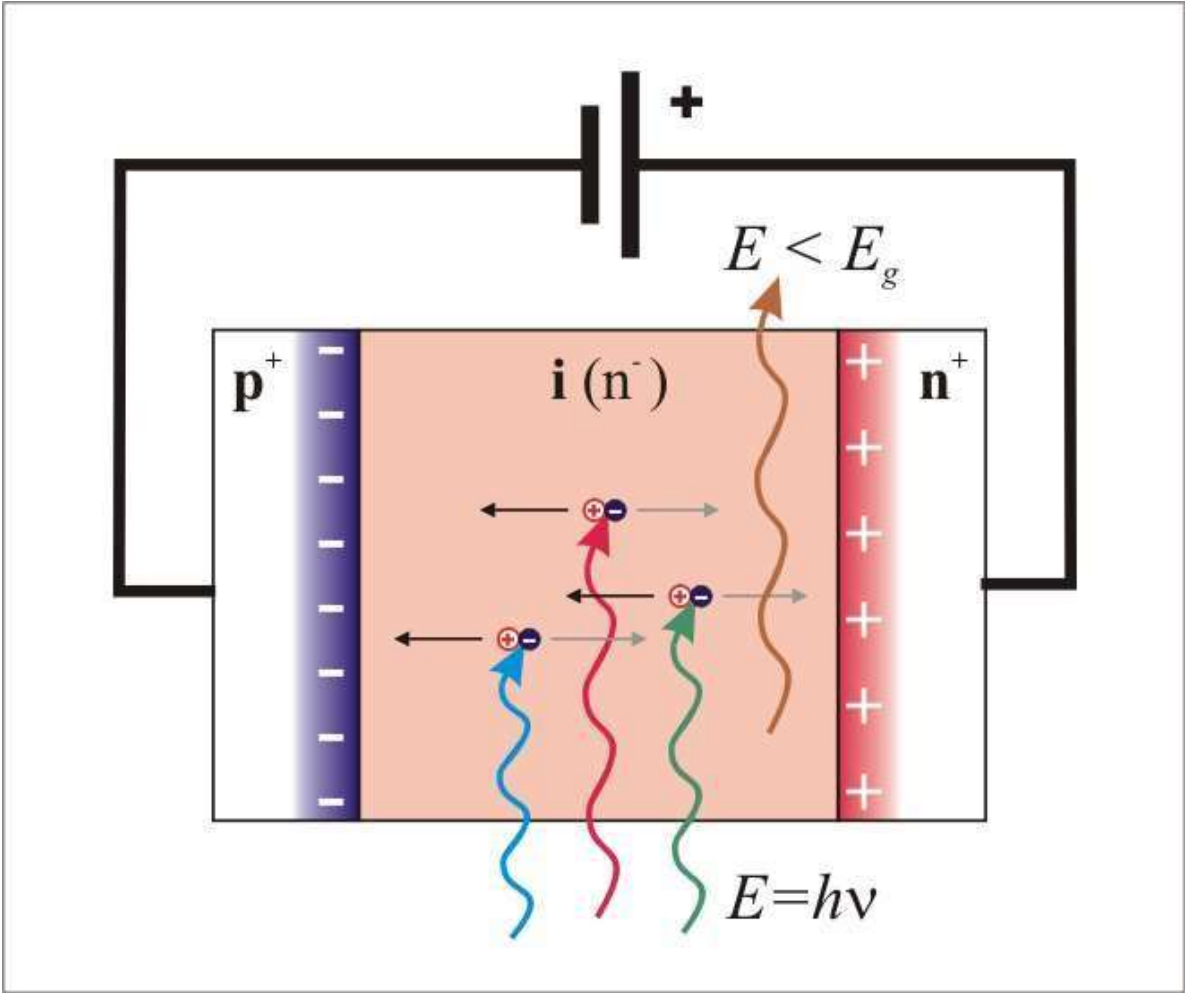

CHARACTERISTICS.:

- The amount of photo current generated is independent on the amount of incident optical power. As more photons are incident on th active region, more charge carriers are created, hence more photo current.

$$I = s.P$$

Where, I-photo current

s- responsivity of photo diode

P- optical power.

- At high incident light intensity, photo diode is saturated due to depletion of carriers. Thus, excess photons are not absorbed.





Power(P)mW

Photo current(i)mA

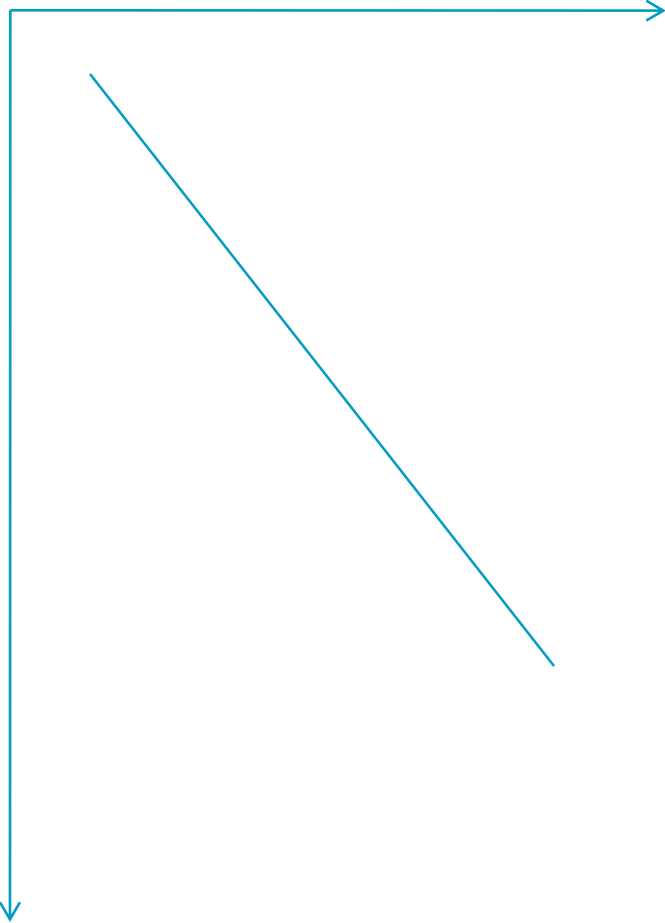

ADVANTAGES:

- Low noise
- Low dark current
- Low bias voltage
- Higher reverse voltages to be tolerated
- High-speed response
- Low junction capacitance
- Large depletion region



DISADVANTAGES OF PIN DIODE :

- Less sensitivity.
- No internal gain.
- Small area.
- Slow response time.
- High reverse recovery time due to power loss are significant.



APPLICATIONS:

- These diodes are used in the RF and also for microwave switches and microwave variable attenuators since they are said to have low capacitance.
- They are used in Photodetectors and photovoltaic cell and the PIN photodiodes are used for fibre optic network cards and also switches.
- These diodes are effectively used for RF protection circuits and it can also be utilized as an RF switch.
- The PIN photodiode is also used to detect X-rays and gamma rays photons.



SOLAR CELL

- It is a device which converts solar(light) energy into electrical energy.
- When light is allowed to fall on the cell, the cell generates voltage across the terminals by photo voltaic effect.
- A solar cell is simply a photo diode, which is operated at zero bias voltage.

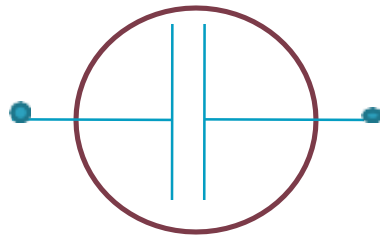

CONSTRUCTION

- A p-n junction made of semiconductor materials such as germanium, silicon and gallium arsenide etc., are essential for construction of solar cell.
 - A heavily doped P and N regions gives a large photo voltage.
 - In order to avoid the recombination of generated electrons and holes in the p & n regions, their thickness is kept very small.
 - It essentially consists of a silicon PN junction diode with a glass window on top surface layer of P material is made extremely thin so, that incident light photon's may easily reach the PN junction.
 - The nickel plated metal rings are placed around p-type and n-type material which acts as their positive and negative output terminals respectively.
 - The surface is coated with anti reflecting coating to avoid the loss of incident energy due to reflection.
- 

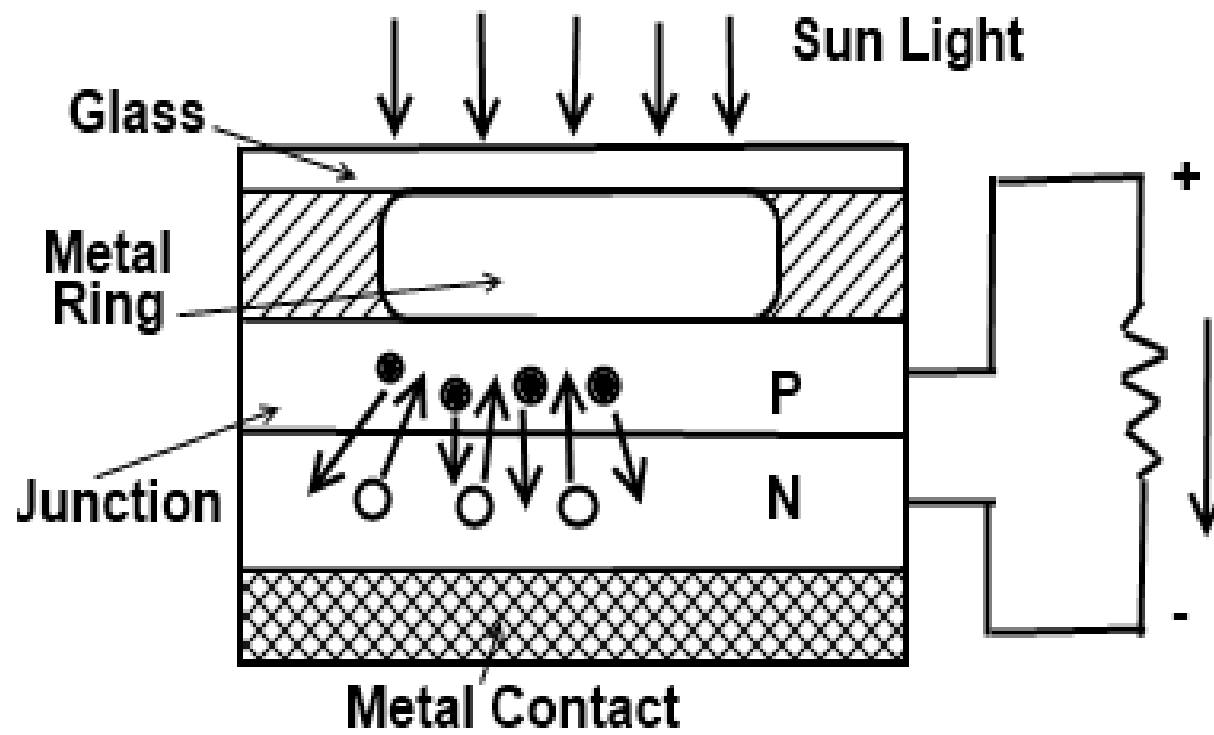

WORKING

- when light is incident on 'P-N' junction, electrons absorb photons having energy greater than the band gap energy.
- hence they can make transition from the valence band to the conduction band & hence contribute current.



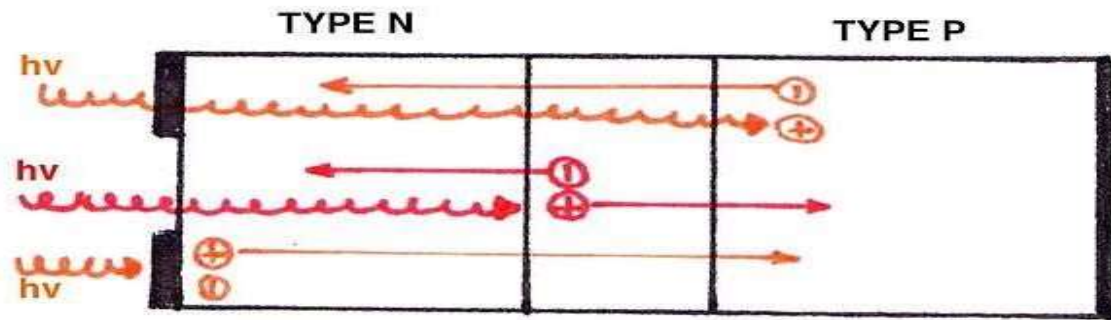
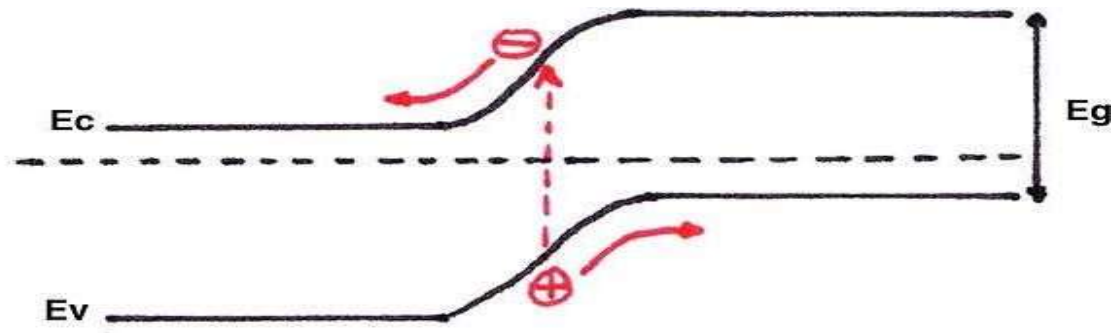

- GENERATION PHOTOCURRENT
- SCATTERING PHOTOCURRENT



CHARACTERISTICS

- The v-i characteristics of a solar cell
- Maximum power will occur at the bend point of the characteristic curve. It is shown in the v-i characteristics of [solar cell](#) by P_m .
- The basic characteristics of a solar cell are the short-circuit current (I_{SC}), the open-circuit voltage (V_{OC}), the fill factor (FF) and the solar energy conversion efficiency (η). The influence of both the diode saturation current density and of I_{SC} on .



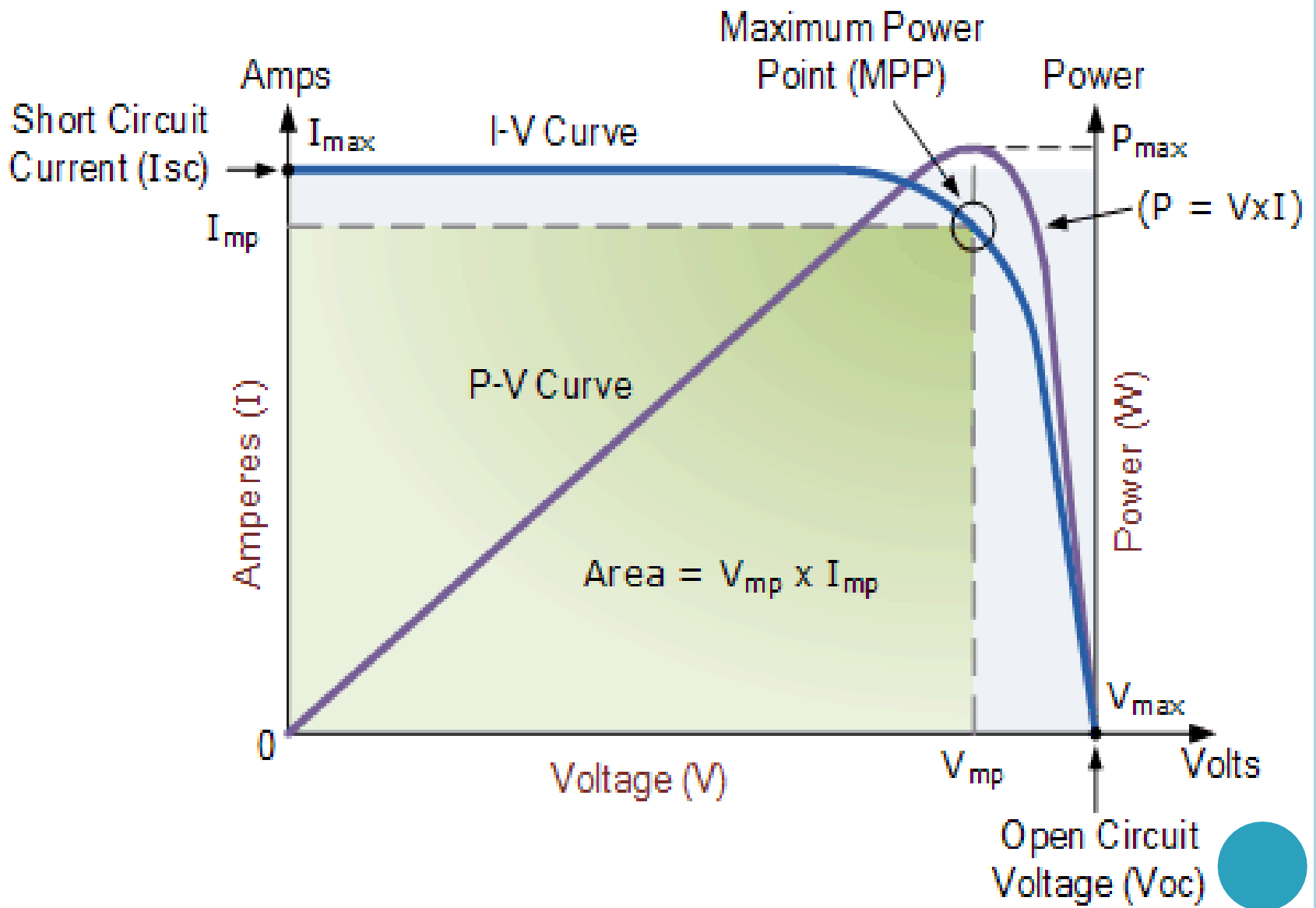

EFFICIENCY:

Solar cell Efficiency (Maximum):-

$$\eta_{max} = \frac{P_{max}}{E * A_c} \times 100 \%$$

P_{max} = Maximum Power Output (in W)

E = incident radiation flux (in W/m²)

A_c = Area of Collector (in m²)



FILL FACTOR: THE FILL FACTOR (FF) IS AN IMPORTANT PARAMETER THAT DETERMINES THE POWER CONVERSION EFFICIENCY OF AN ORGANIC SOLAR CELL.

$$\text{FILLFACTOR} = \frac{I_{MP} * V_{MP}}{I_{SC} * V_{OC}}$$

$$P_{MP} = FF * I_{SC} * V_{OC}$$



FIGURE OF MERIT OR ADVANTAGES

- Solar energy is clean and non polluting
- Best renewable energy
- Solar cells do not produce noise
- Solar cell needs little maintenance
- Highly reliable
- Long lasting
- Panel cost is now reducing
- Unlike batteries or fuel cells, solar cells do not utilize chemical reactions or require fuel to produce electric power, and, unlike electric generators, they do not have any moving parts.



APPLICATIONS

- Toys & watches
- Calculators
- Electrical fences
- Remote lighting systems
- Water pumping
- Water treatment
- Emergency power
- Portable power supplies
- satellites



INTRODUCTION:

- The light emitted from a conventional light source said to be incoherent because the radiation emitted from different atoms do not bear any definite phase relationship with each other.
- LASER-light amplification by stimulated emission of radiation.
- LASER is also a light source having high monochromacity, high intensity, high directionality and high degree of coherence.
- Lasing has been extended up to γ -rays. γ -Ray Lasers are called as Grasers.
- The Laser is the outgrowth of Maser which means microwave amplification by stimulated emission of radiation.
- If the stimulated radiation lies in optical region, then the device is called as optical MASER or LASER.



UNIT

LASERs & Fiber Optics



○ **CHARACTERISTICS OF LASER:**

- The important characteristics of a LASER radiation are

Laser is highly monochromatic

Highly directional

Highly coherent

Highly intensified

- **Monochromatic:** The Laser light is highly monochromatic. The spread is of the order of few angstroms only. That is less than 10Å. And Laser emit continuous waves of very long duration.
- **Directional:** The emitted lights from LASER are only in one direction as the photons travelling along the optical axis of the system.



- **Coherent:** the waves emitted by a laser source will be in phase and are of same frequency. Whereas convention light source [incandescent lamp] emits random wavelength light waves with no common phase relationship.
- **Intensity:** a LASER beam emits light in the form of a narrow beam which propagates in the form of plane waves. As the energy is concentrated in a very narrow region, its intensity is tremendously high. It is estimated that light from a typical 1mW LASER is 10000 times brighter than the light from the source at the earth's surface.
- **Divergence:** the divergence or angular speed of the LASER beam is extremely small.



INTERACTION OF RADIATION WITH MATTER:

- Consider a radiation interacts with matter. for interaction to occur, first of all the energy of the interacting photon must match with energy difference between the two states of the atoms involved in the interaction.
- When this radiation interacts with matter there is a chance of three process
 - stimulated absorption
 - spontaneous emission
 - stimulated emission



- Stimulated absorption:

If the radiation interacts with atoms in the lower energy state say E_1 , the atoms absorb the energy and get excited to higher energy state E_2 . This process is called stimulated absorption.

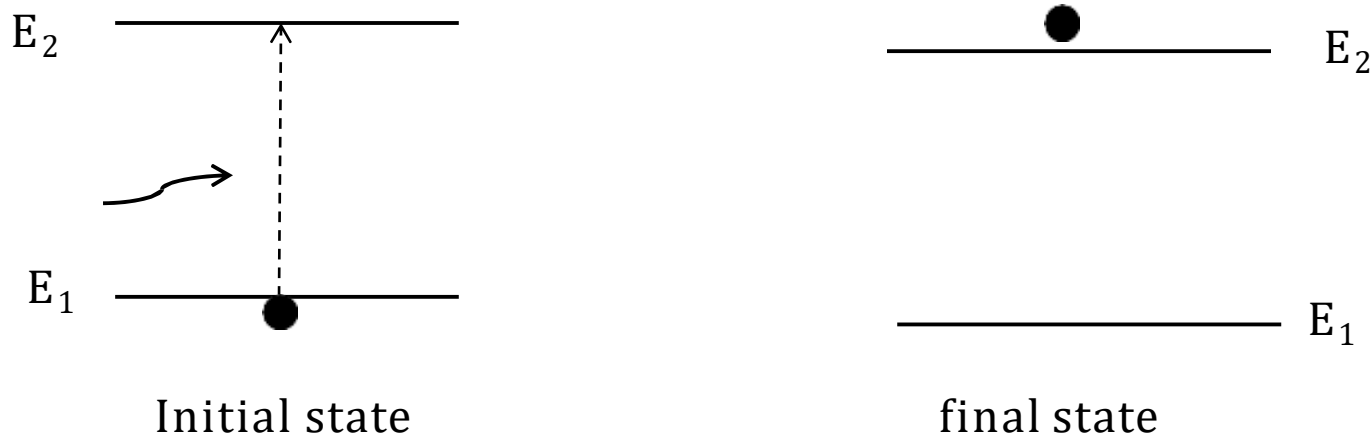

- Stimulated emission:

If the radiation interacts with atoms which are already in the excited state, then the atom comes to the lower energy state. This occurs with the emission of photons of energy $h\nu$. This process is called stimulated emission.

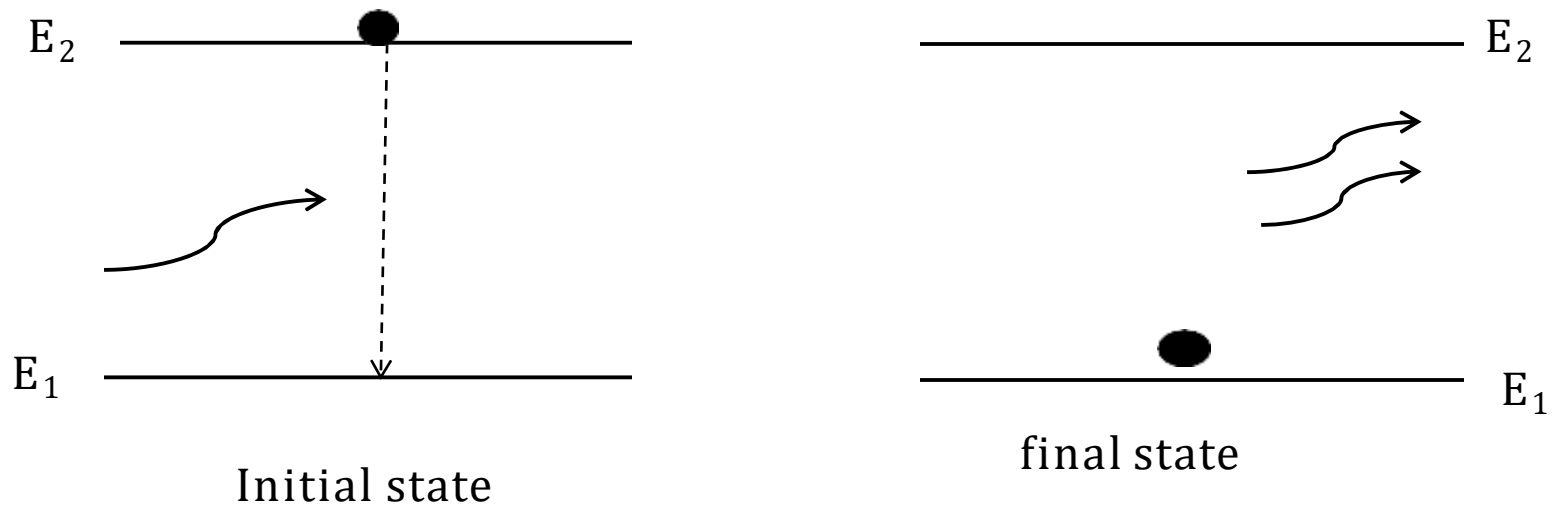

- Spontaneous emission:

In this process, the atoms in the excited state drop to the lower energy state after they have stayed in excited state for some time called life time.

During this process, photon of energy has been emitted.

The life time of the particle in the excited state is of the order 10^{-8} sec.

There exist some excited states in which life time is much greater than 10^{-8} sec.

These states are called metastable states. The life time of the atom in metastable state is of the order 10^{-3} sec.



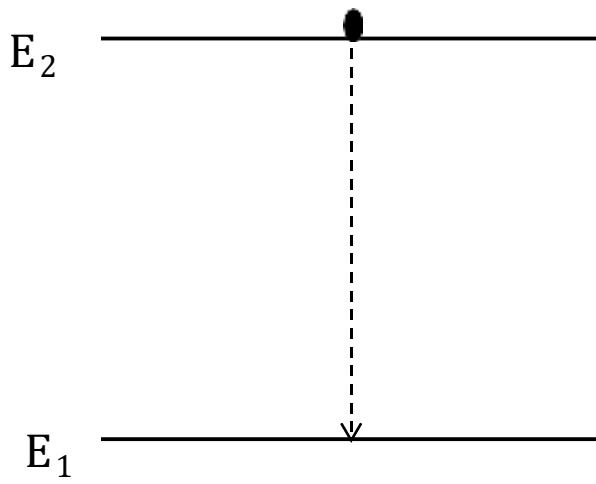

Initial state

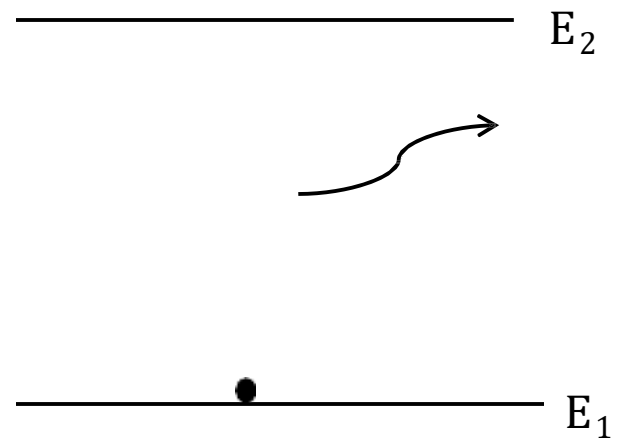

final state



NORMAL AND META STABLE STATES:

- The life time of the particle in the excited state is of the order 10^{-8} sec. Those states are called normal energy states.
- There exist some excited states in which life time is much greater than 10^{-8} sec. These states are called meta stable states.
- The life time of the atom in meta stable state is of the order 10^{-3} sec.



EINSTEIN COEFFICIENTS AND THEIR RELATIONS:

- Consider a substance, in which the process of stimulated absorption, spontaneous emission and stimulated emission occur simultaneously.
- Let N_1 be the no. of atoms per unit volume with energy E_1 and N_2 be the no. of atoms per unit volume with energy E_2 .
- Let 'n' be the no. of photons per unit volume with a frequency ν such that $h\nu = E_2 - E_1$.
- Then, energy density of interacting photon is given by

$$\rho(\nu) = nh\nu \text{ ----- (1)}$$



- Stimulated absorption rate depends on the no. of atoms available in E_1 as well as the energy density interacting radiation. Therefore, stimulated absorption rate is

$$\propto N_1$$

$$\propto \rho(\nu)$$

$$= \rho(\nu) N_1 B_{12} \dots \dots \dots (2)$$

- Where B_{12} is Einstein coefficient of stimulated absorption.



- Once they are excited to higher states, after their life time they move to their lower energy level spontaneously emitting photons.
- This spontaneous emission rate depends on the no. of atoms in the excited energy state. Therefore, spontaneous emission rate is

$$\begin{aligned} &\propto N_2 \\ &= N_2 A_{21} \dots \dots \dots (3) \end{aligned}$$

- Where A_{21} is Einstein coefficient of spontaneous emission.



- Before de-excitation to lower energy level, they may interact with photons resulting in stimulated emission of photon.
- That stimulated emission rate depends on

$$\propto N_2$$

$$\propto \rho(\nu)$$

$$= \rho(\nu) N_2 B_{21} \dots \dots \dots (4)$$

- Where B_{21} is Einstein coefficient of stimulated emission.



- At equilibrium, the upward transition rate must be equal to downward transition rate.

$$\rho(\vartheta)N_1B_{12} = \rho(\vartheta)N_2B_{21} + N_2A_{21}$$

$$\rho(\vartheta) = \frac{A_{21}N_2}{N_1B_{12} - N_2B_{21}}$$

$$\rho(\vartheta) = \frac{A_{21}/B_{21}}{\frac{N_1}{N_2} \frac{B_{12}}{B_{21}} - 1} \dots\dots\dots (5)$$



- According to Maxwell Boltzmann statistics, the population of various levels is

$$N_i = N_0 g_i \exp \frac{-E_i}{KT} \dots \dots \dots (6)$$

- Hence,

$$N_1 = N_0 g_1 \exp \frac{-E_1}{KT}$$

$$N_2 = N_0 g_2 \exp \frac{-E_2}{KT}$$

$$\frac{N_1}{N_2} = \frac{g_1}{g_2} \exp \frac{E_2 - E_1}{KT} \dots \dots \dots (7)$$



- Substituting (7) in (5)

$$\rho(\nu) = \frac{\frac{A_{21}}{B_{21}}}{\left(\frac{g_1 B_{12}}{g_2 B_{21}} \exp \frac{E_2 - E_1}{KT}\right) - 1} \dots \dots \dots (8)$$

- From Planks law of black body radiation, the radiation density

$$\rho(\nu) = \frac{8\pi h \frac{\nu^3}{c^3}}{\exp \left(\frac{E}{KT}\right) - 1} \dots \dots \dots (9)$$



- Comparing equations (8) & (9)

$$\frac{g_1}{g_2} \cdot \frac{B_{12}}{B_{21}} = 1 \dots\dots\dots (10)$$

$$\frac{A_{21}}{B_{21}} = 8\pi h \frac{\nu^3}{c^3} \dots\dots\dots (11)$$

- Equations (10) & (11) are called as Einstein relations.



- Case-1:

The ratio of spontaneous emission rate to the stimulated emission rate is given by

$$R = \frac{N_2 A_{21}}{N_2 B_{21} \rho(\nu)} = \frac{A_{21}}{B_{21} \rho(\nu)} = \exp\left(\frac{h\nu}{KT}\right) - 1$$

Therefore, spontaneous emission rate predominates. To make R smaller, $\rho(\nu)$ has to be made large.



- Case-2:

The ratio of stimulated emission rate to the stimulated absorption rate is given by

$$Q = \frac{N_2 B_{21} \rho(\nu)}{\rho(\nu) N_1 B_{12}} = \frac{N_2}{N_1}$$

At thermal equilibrium, $\frac{N_2}{N_1} \ll 1$

- Instead of this, if we create $N_2 > N_1$, stimulated emission will be predominant. If stimulated emission predominates the photon density increases and LASER occurs.



- To achieve more stimulated emission, population of excited state (N_2) should be made larger than the population of the lower state (N_1).
- This condition is called population inversion.
- To have LASER,
 - Create population inversion.
 - Increase the energy density of interacting radiation.



POPULATION INVERSION:

- By making, $N_2 > N_1$ population inversion has been achieved.
- The states of system in which the population of higher energy state is more in comparison with the population of lower energy state are called negative temperature states.
- Population inversion can be achieved by
 - Three level scheme
 - Four level scheme



- Three level scheme:

If the collection of atoms is intensely pumped, a large no. of atoms are excited through stimulated absorption to the highest energy level E_2 .

If the level E_2 has very short life time, the atoms decay fast to level E_1 .

If the level has relatively longer life time [a state known as metastable state] atoms tend to accumulate at E_1 .



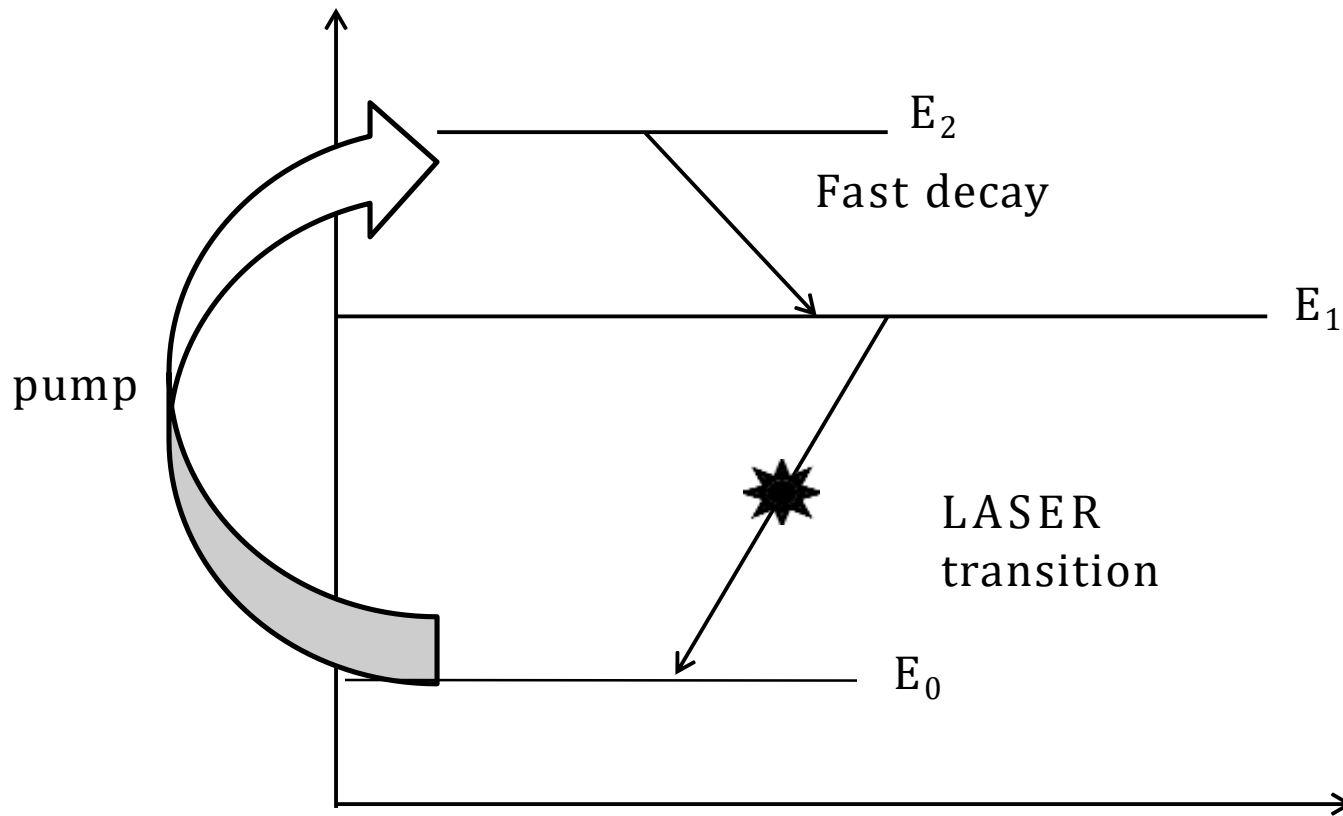

With intense pumping, E_1 is more populated than E_0 . And LASER transition takes place between level E_1 and level E_0 .

Hence population inversion is achieved between E_1 and E_0 .

If the pumping continues when the condition $N_1 > N_0$ is reached, stimulated emission rate exceeds stimulated absorption rate.

This scheme can be worked in pulsed mode only. For example ruby laser.

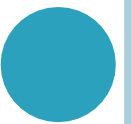

- Four level scheme:

On pumping, the atoms are lifted from the ground state to the highest of the four levels (E_3) involved in the process.

From this level E_3 , the atoms decay to the metastable state E_2 , and the population of this state grows rapidly. Hence, population inversion exist between E_2 and E_1 .

Therefore, laser transition takes place between higher energy level E_2 and lower energy level E_1 .



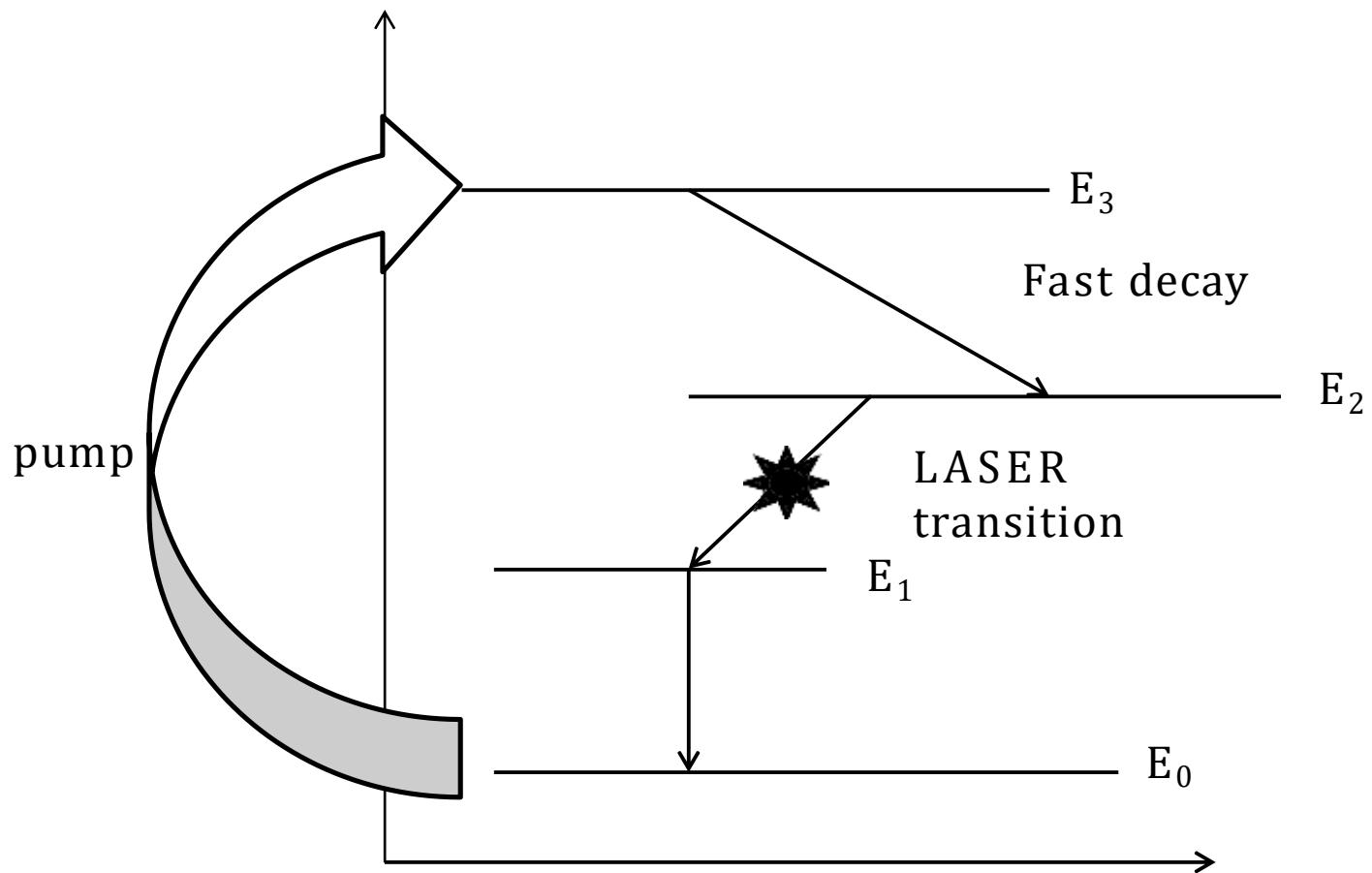

To have continuous o/p,

For this to happen E_1 to E_0 transition should be fast. If this transition ($E_1 - E_0$) is slow, even four level lasers will work in pulsed mode only.

Eg: He-Ne laser for continuous o/p and N_2 laser for pulsed o/p.



PUMPING AND DIFFERENT MECHANISMS:

- The lifting of atoms from lower energy state to higher energy state is called as pumping.
- There four different methods of pumping
 - Optical pumping
 - Electric discharge method
 - Chemical reaction method
 - Injection current method



MECHANISM FOR PUMPING SCHEMES:

There are different mechanisms applied to pump the atoms to higher energy states to create population inversion. They are

Optical pumping:

- solid lasers are optically pumped using Xenon flash lamps.
- Since these materials have very broad band absorption, sufficient amount of energy is absorbed from the emission band of flash lamp and population inversion is created.
- For example Ruby LASER, Nd:YAG, Nd:glass, dye etc.



Chemical reaction:

- In this the energy is supplied directly from a chemical reaction not from any other source.
- For example carbon dioxide laser.



Electric discharge:

- Population inversion can also be achieved by direct excitation as it occurs in an electric discharge.
- The best example for this method is argon ion laser.
- In some lasers one type of atoms are excited by electric discharge.
- These atoms collide in elastically with another type of atoms.
- The latter atoms provide population inversion needed for laser emission.
- The best example is He-Ne laser.



Injection current:

- In some semiconductors, lasing action is produced by the conversion of electrical energy into light energy in which recombination of electrons and holes occurs.
- For example gallium arsenide laser.



LASER ACTION:

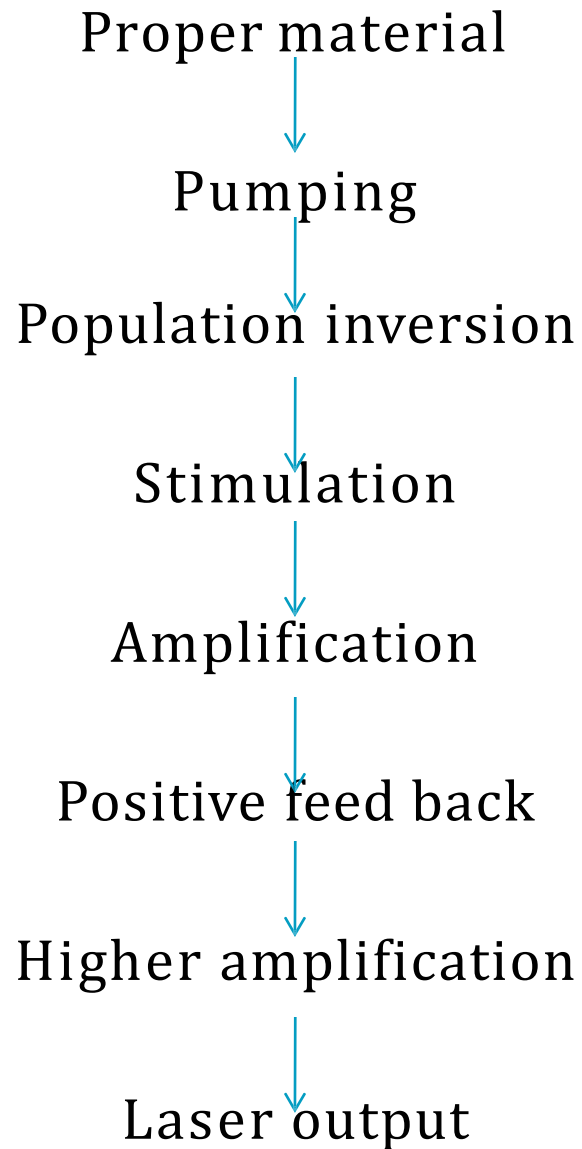

ELEMENTS OF LASER:

Active medium:

- The active medium is a collection of atoms or molecules that can be excited to a state of inverted population. The two states chosen for the lasing transition must possess certain characteristics.
- First, atoms must remain in the upper lasing level for a relatively long time to provide more emitted photons by stimulated emission than by spontaneous emission.
- Second, there must be an effective method of “pumping” atoms from the highly populated ground state into the upper lasing state in order to increase the population of the higher energy level over the population in the lower energy level.
- The active medium may be a gas, a liquid, a solid material or a junction between two slabs of semiconductor materials.



Pumping mechanism:

- The excitation mechanism is a source of energy that excites, or pumps, the atoms in the active medium from a lower to a higher energy state in order to create a population inversion.
- In gas and semiconductor lasers, the excitation mechanism usually consists of an electric current flow through the active medium.
- Solid and liquid lasers most often employ optical pumps.



Resonant cavity:

- The feedback mechanism returns a portion of the coherent light originally produced in the active medium back to the active medium for further amplification by stimulated emission
- The feedback mechanism usually consists of two mirrors. Each one at end of the active medium aligned in such a way that they reflect the coherent light back and forth through the active medium.

Laser action:

- when the excitation mechanism of a laser is activated, energy flows in to the active medium, causing atoms to move from the ground state to certain excited state. In this population inversion is created.
- Some of the atoms in the upper lasing level spontaneously emitting incoherent photons. When these photons travel along axis of the active medium produce stimulated emission.



RUBY LASER

- Ruby laser is a three level solid state laser
- It was constructed by Malman in the year 1960.
- It is a pulsed laser having very high power of hundreds of megawatt in single pulse with about 10 ns duration.
- Ruby rods are prepared from Al_2O_3 doped with 0.05% chromium by weight. So, that some of the Al^{3+} ions are replaced by Cr^{3+} ions.



ELEMENTS OF LASER

- **Active medium:** ruby crystal is in the form of a rod of nearly 10 cm in length and 0.8 cm in diameter.
- **Resonant cavity:** flat end faces A and B of the rod are made strictly parallel, plane and silvered so that the end faces A becomes fully reflecting and the end face B partially reflecting. The rod is surrounded by a cylindrical glass tube through which water circulates to keep the rod cool.
- **Pumping system:** the ruby rod is arranged along the axis of a helical xenon flash tube so that the coils of the tube surround the rod. The flash tube is provided with a suitable power supply to flash for several milliseconds.



CONSTRUCTION:

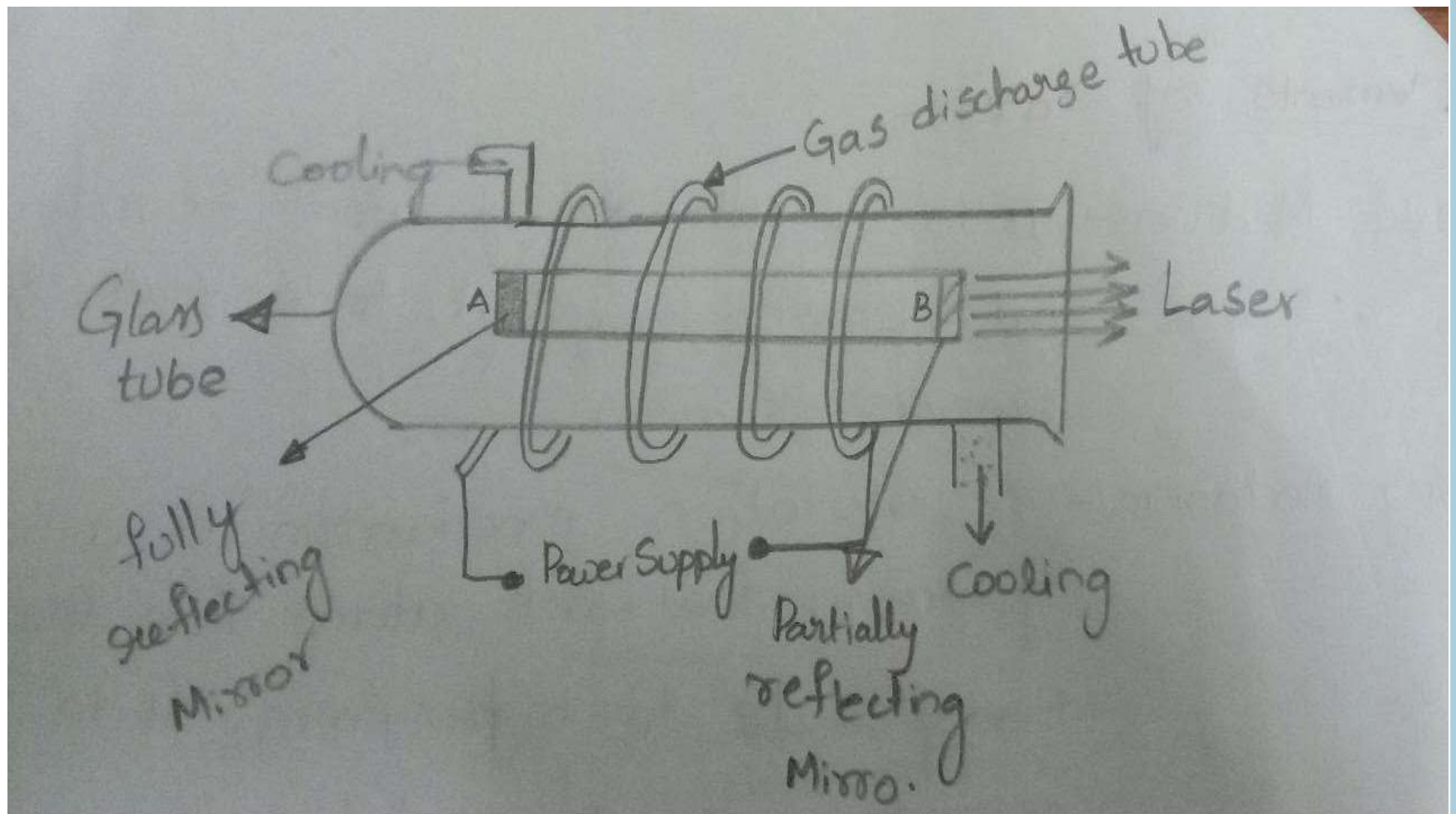

WORKING:

- when light from the flash tube is made to fall upon the ruby rod, the chromium atoms get excited from level 1 to energy level 3.
- Chromium ions stay here for a very short time of the order of seconds. The transition from E_3 to E_2 is non radiative in nature but produces heat. Hence cooling system is essential.
- As the life time of E_2 is much longer, the no. of ions in this state goes on increasing while in the ground state goes on decreasing. In this way population inversion exist between level 2 and level 1.



- When an ion passes spontaneously from the metastable state to the ground state it emits a photon of wave length 694.3nm.
- This photon travels through the ruby rod and if it is moving parallel to the axis of the crystal, is reflected back and forth by the silvered ends until it stimulates an excited ion in level 2 and causes it to emit fresh photon in phase with the earlier photon.
- This stimulated transition triggers the laser transition. The process is repeated again and again and the photons thus get multiplied.
- When the photon beam become sufficiently intense, such that the part of it energies through the partially silver end of the crystal. O/p is pulsed.



ENERGY LEVEL DIAGRAM

- The energy level diagram of ruby laser is

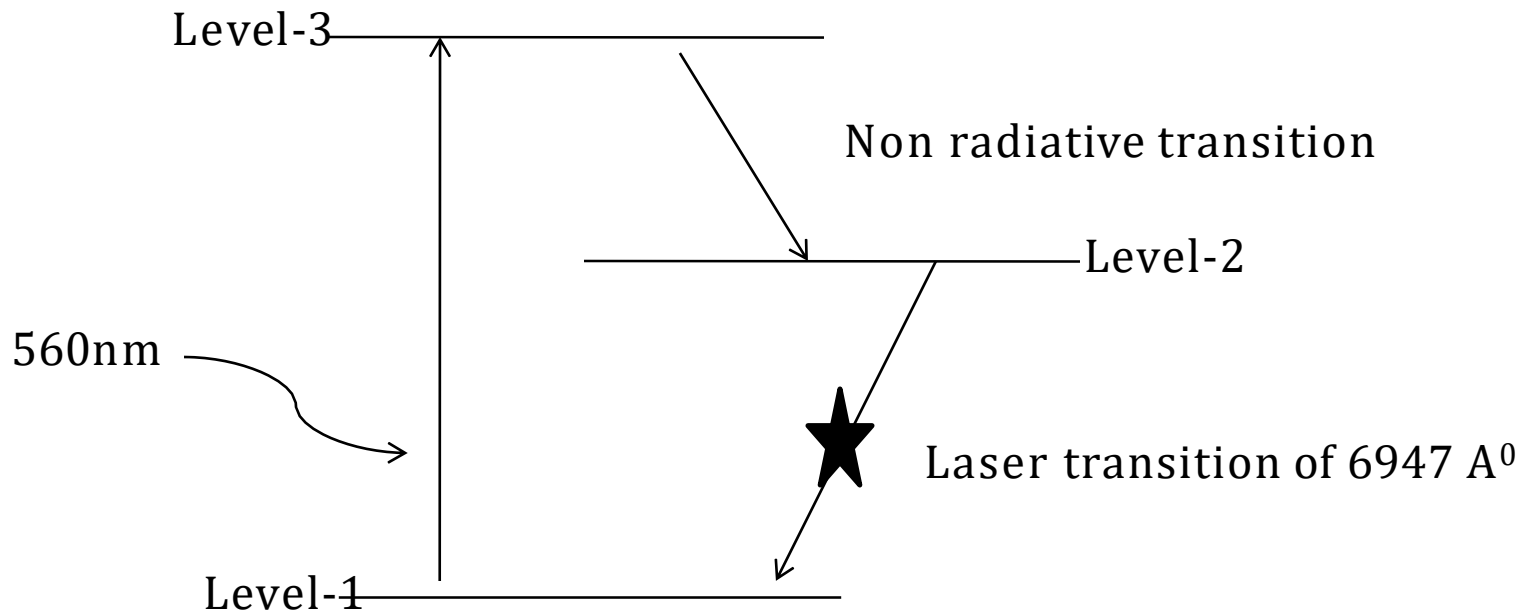

APPLICATIONS:

- Holography
- For drilling high quality holes
- In military as target designators and range finders.



HE-NE LASER

- For the continuous laser beam, He-Ne laser is used.
- The o/p laser is highly mono chromatic, coherent and directional but o/p is generally few mill watts.
- He-Ne gas lasers are used in holograms and in medicine.



ELEMENTS OF LASER

- Active medium: This laser consists of a gas discharge tube of length 80cm and diameter 1cm. The tube is made up of quartz and is filled with a mixture of neon under pressure of 0.1 mm of Hg and helium under a pressure of 1mm of Hg. The ratio of He-Ne mixture is 10:1.
- Resonant cavity: The mixture is enclosed between a set parallel mirrors forming a resonating cavity. One of the mirrors is completely reflecting and the other is partially reflecting.
- Pumping scheme: The electric discharge is efficient method of producing population inversion in these gas lasers.



CONSTRUCTION

- The construction of this laser is as shown below

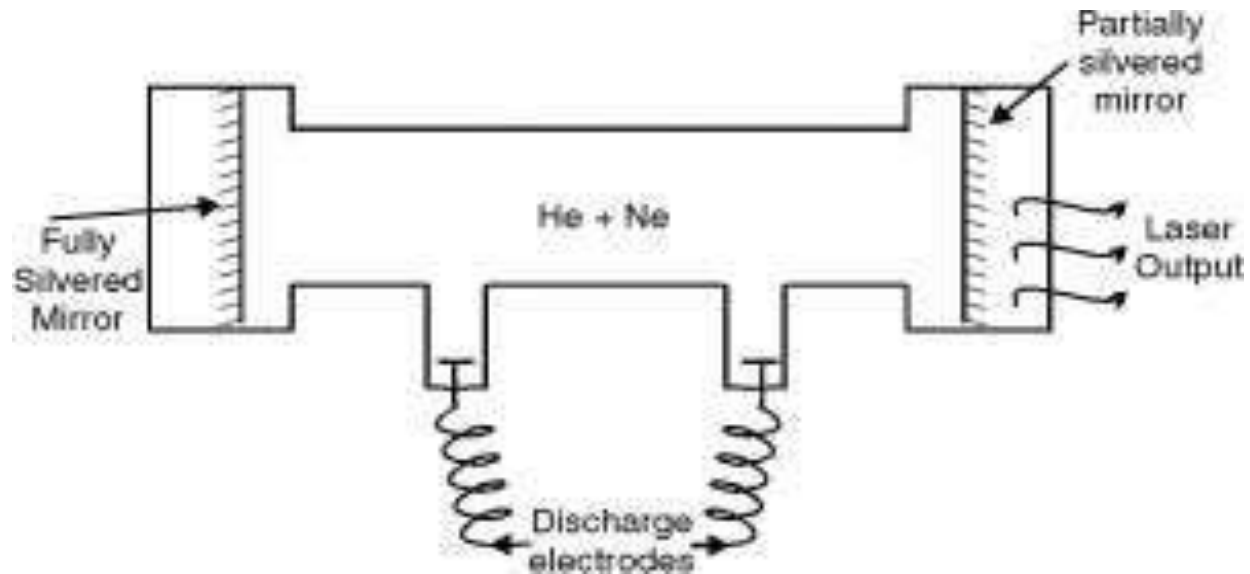

WORKING

- When discharge is passed through the mixture of gas, the electrons collide with helium atoms and excite them to the meta stable states E_2 and E_3 . This is called pumping. The He atoms continue in these states in long time.
- The levels E_2 and E_3 of helium have nearly the same energy as the E_4' and E_6' of neon.
- During the de-excitation of He atoms, they collide with unexcited neon atoms raising them to the levels E_4' and E_6' . Hence population inversion occurs w.r.t the levels E_3' and E_5' .



- Therefore the transitions occur are
 - E_6 , to E_5 , producing laser of $3.39 \mu\text{m}$
 - E_6 , to E_3 , producing laser of 632.8nm
 - E_4 , to E_3 , producing laser of $1.15 \mu\text{m}$
- From the level E_3' the Ne atoms drop to level E_2' by spontaneous emission and de-excited to ground level by collisions. Thus, they are again ready to go through the cycle.

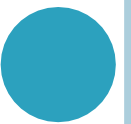

ENERGY LEVEL DIAGRAM

- The different energy levels of helium atoms and neon atoms is

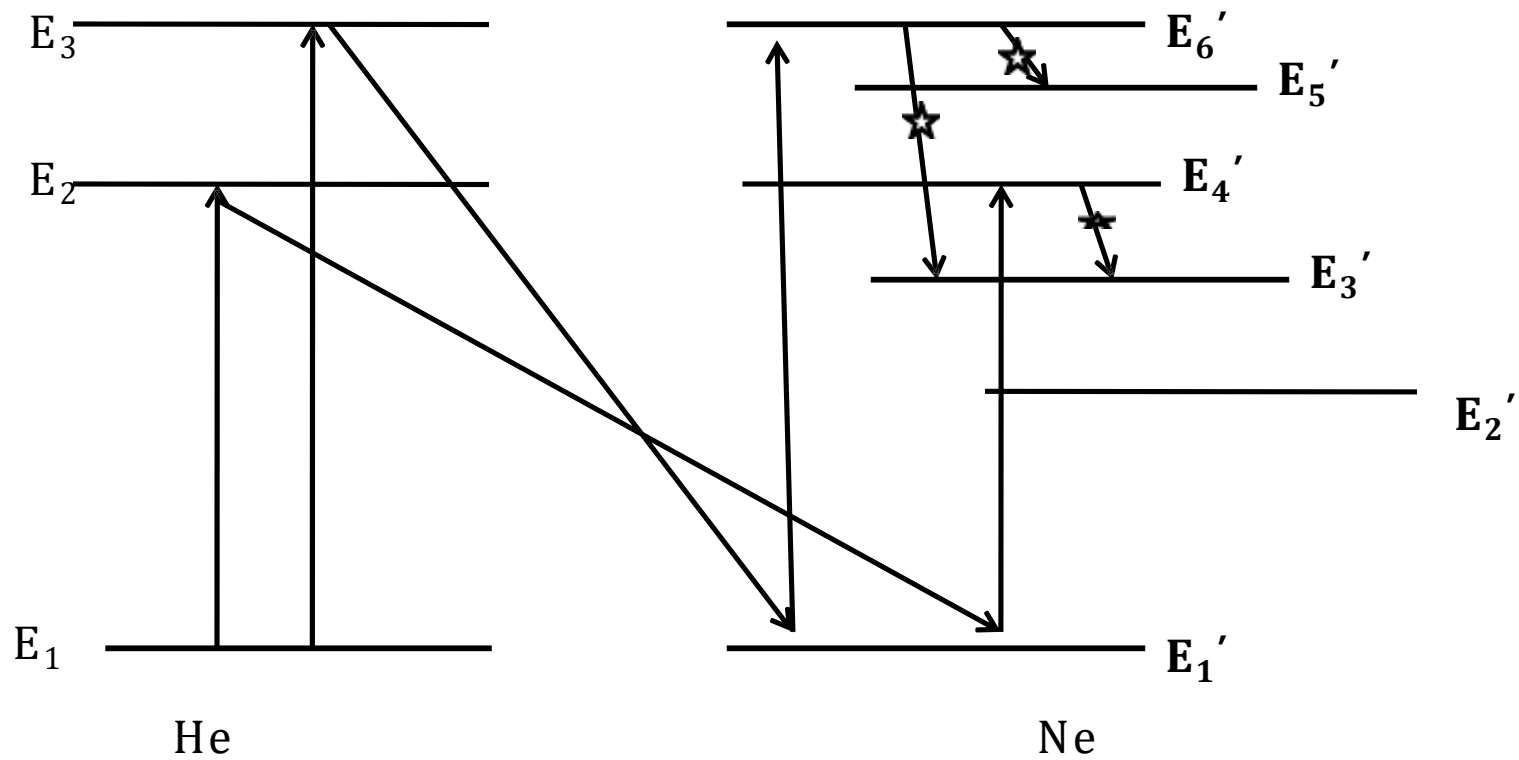

APPLICATIONS:

- Barcode scanners.
- Tool alignment.
- Non-contact measuring and monitoring.
- Blood analysis.
- Particle counting and food sorting.
- Alignment of high power CO₂ and YAG treatment lasers and pointing beams.



○ Medical applications of LASERS:

- Lasers are used in eye surgery by ophthalmologists, especially in detached retina. The retina can be attached to the choroid by heating it over a no. of spots. The heating can be achieved by focussing a laser beam of predetermined intensity on the retina. This can be done by using Argon ion lasers
- Laser angioplasty: lasers are used for treatment such as plastic surgery, skin injuries etc., this can be done by using Nd:YAG lasers.
- Dermatologists use lasers for the treatment to remove moles and tumours developed in skin tissue and also to remove tattoos.
- Lasers are used in stomatology- the study of mouth and its diseases. Mouth ulcers can be cured by exposing it to a laser beam.
- Lasers are used to destroy kidney stones and gall stones. The laser pulses break the stones into small pieces.
- Lasers are used in cancer diagnosis and therapy.
- Lasers are used in blood loss less surgery
- Lasers are used to control haemorrhage
- Using organ and lasers, liver and lung treatment can be carried out.
- Lasers are used in endoscopes to detect hidden parts.



- Applications of LASER in scientific research:
 - Lasers are used to study the nature of chemical bonds.
 - Used for isotope separation.
 - Used to estimate the size and shape of biological cells.
 - Used to find the size of dust particles.
 - Used for recording and reconstruction of holograms.
 - Lasers are used to develop hidden finger prints and to clean delicate pieces of art.



PRINCIPLE

- optical fibres are based on the principle of total internal reflection.
- When a light ray is travelling from one medium to another medium two things may happen.

They are

- Reflection-the incident ray will get back in to same medium
- Refraction-the incident travels in to other medium by bending

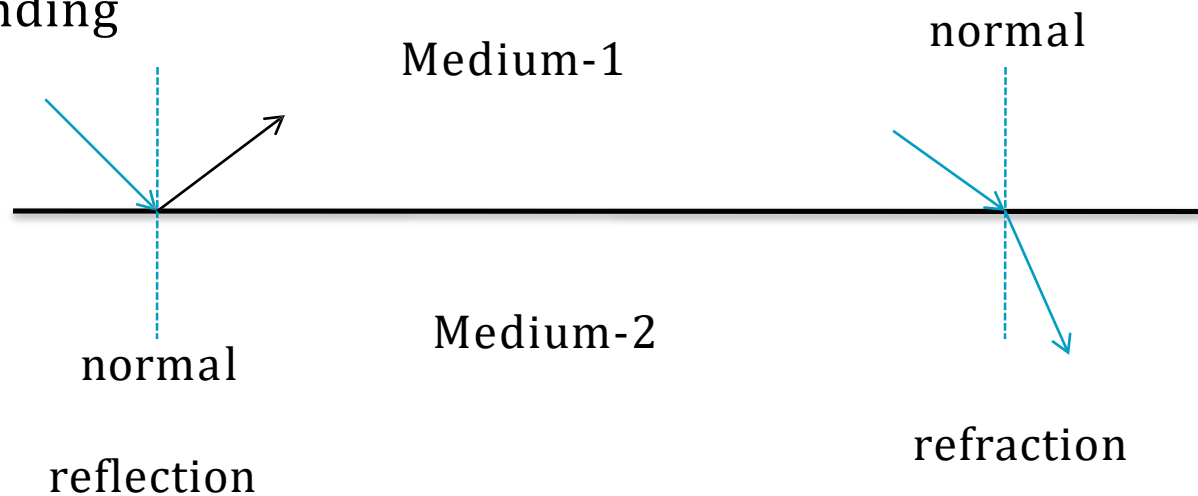

- The bending of light ray in refraction depends on the medium it is travelling from.
- A medium with lower refractive index is called rarer medium and a medium with higher refractive index is called denser medium
- When the light is travelling from rarer to denser medium, the refracted ray will bend towards the normal.
- When the light is travelling from denser to rarer medium, the refracted ray will bend away from the normal.

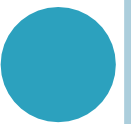

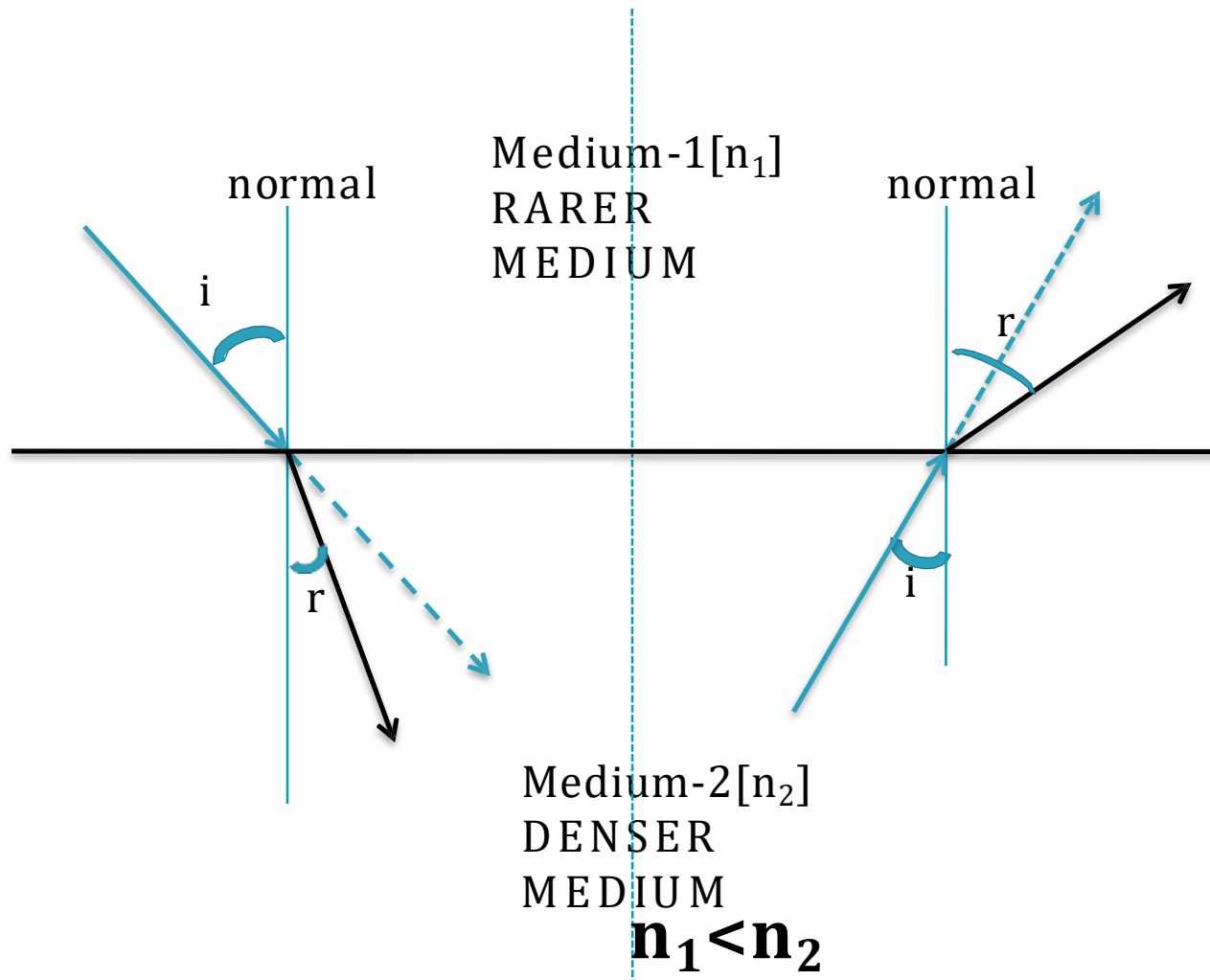

- As the angle of incidence increases angle of refraction also increases.

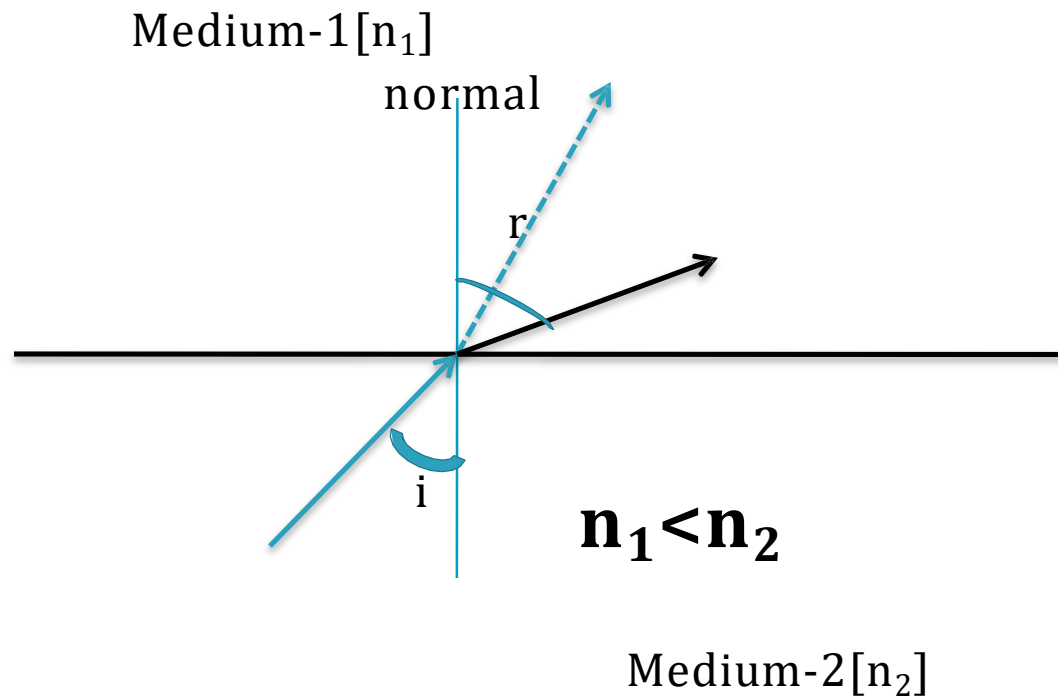

- At a particular angle of incidence, the angle of refraction is equal to 90° (refracted ray traces the interface). SUCH AN ANGLE OF INCIDENCE IS CALLED CRITICAL ANGLE.

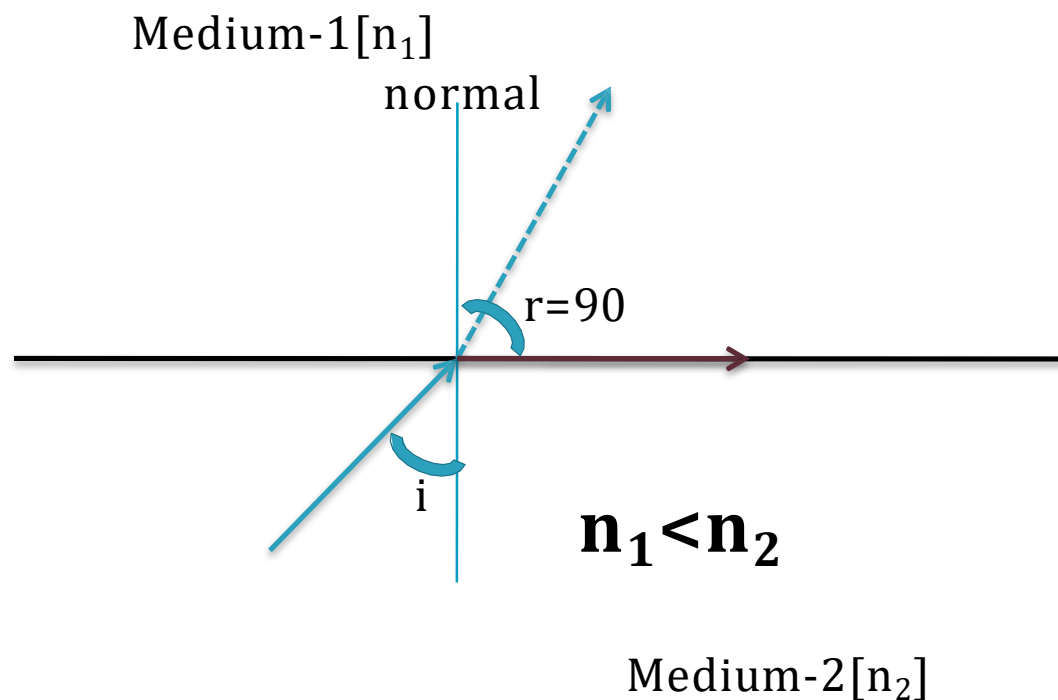

- If the angle of incidence is further increased, the angle of refraction increases further ($r > 90$). i.e., the ray will get back in to same medium. This phenomenon is called total internal reflection. Which is basic principle for light transmission through an optical fibre.

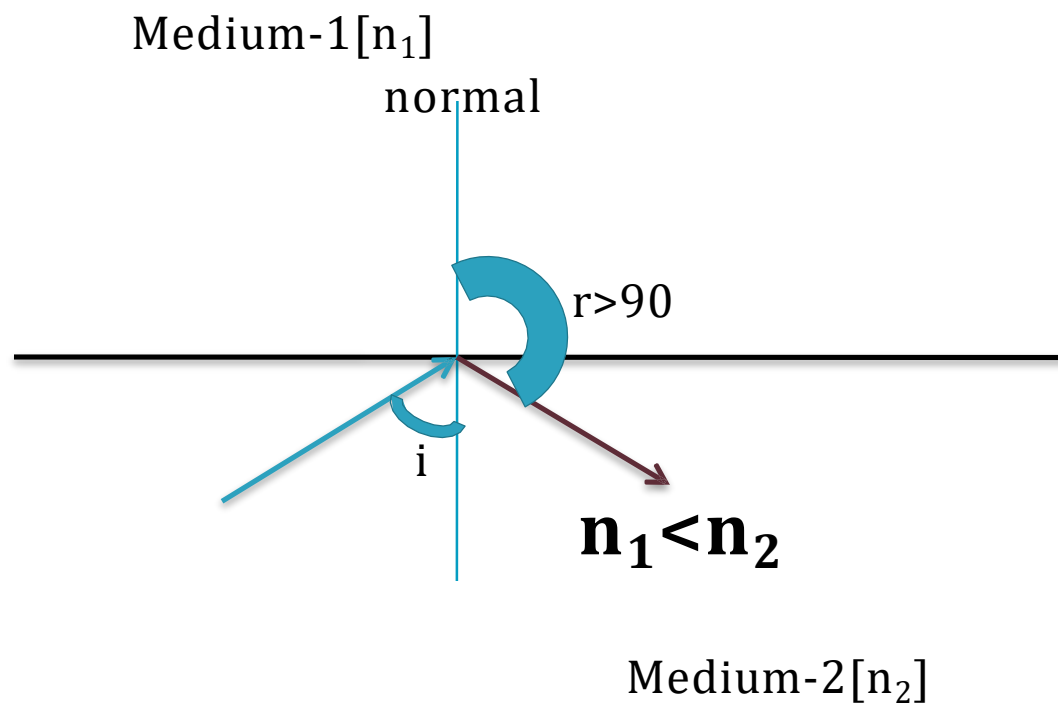

CONSTRUCTION

- An optical fibre has a cylindrical shape consisting of three sections

- The core
- The cladding and
- The outer jacket.

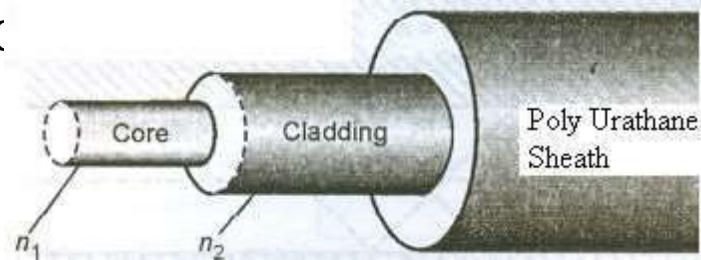

- The structure of optical fibre is as shown.
- The fibre has a core surrounded with a cladding with refractive index slightly less than that of the core.
- To give protection to the fibre, an outer jacket is used.



WORKING

- The condition for total internal reflection is
refractive index of core, $n_1 >$ refractive index of cladding,
 n_2
angle of incidence > critical angle
- The light launched inside the core through its one end propagates to the outer end due to total internal reflection at the core cladding interface.



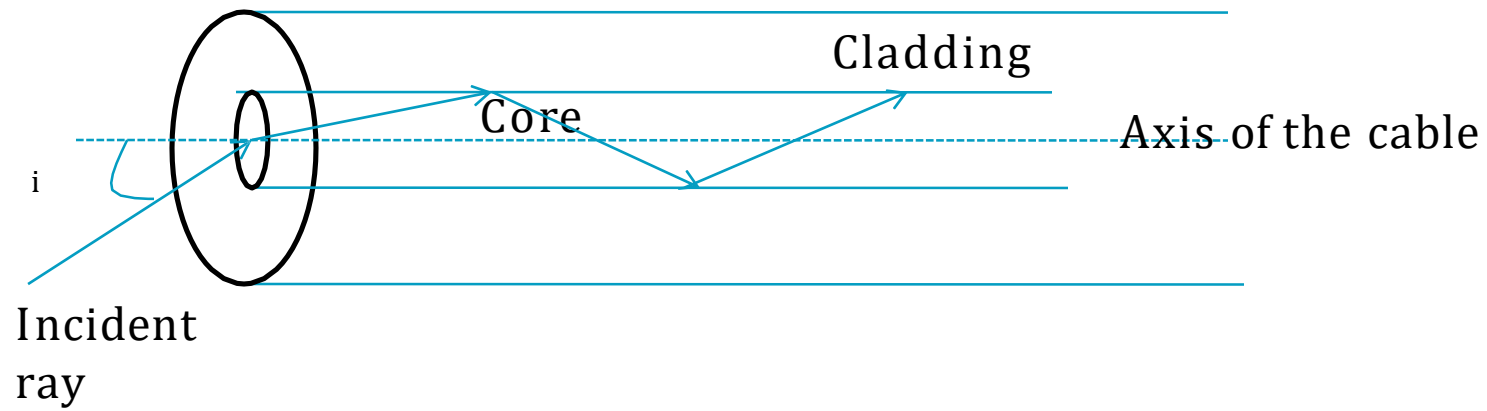

ACCEPTANCE ANGLE

- When we launch a light beam into a fibre at its one end, the rays which make the angle of incidence greater than the critical angle at core cladding interface undergo total internal reflection and propagate through the core. Other rays are lost.
- So, we have to launch the beam at its end to enable the entire light to pass through the core. This maximum angle of launch is called acceptance angle.



ACCEPTANCE CONE

- If the acceptance ray is rotated around the fibre axis keeping same, then it describes a conical surface.
- Now, only those rays which are funnelled into the fibre within this cone having a half angle are propagated.
- Therefore, the cone is called as acceptance cone.

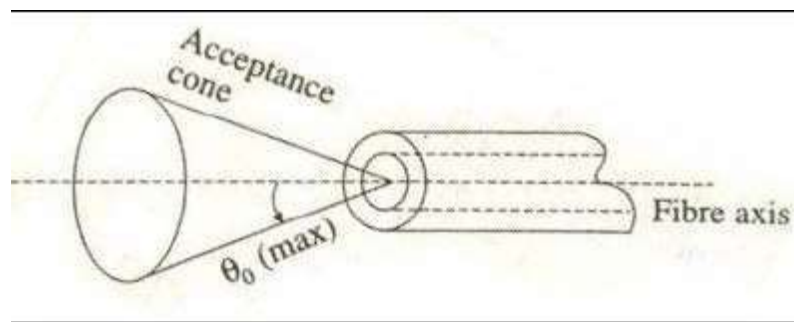

DERIVATION:

- Consider a cylindrical fibre wire which consists of an inner core of refractive index n_1 and cladding of refractive index n_2 where $n_1 > n_2$.
- Let n_0 be the refractive index of medium from which the light ray enters the fibre. This end is called launching end.
- Let the light ray enter the fibre at an angle θ_i (acceptance angle) for which $\theta \geq \theta_c$, so that light stay within the fibre.
- According to snell's law,

$$\frac{\sin i}{\sin r} = \frac{n_2}{n_1}$$



- Applying Snell's law of refraction at point of ray OA in to the core, we have

- From triangle ABC $\frac{\sin \theta_i}{\sin \theta_r} = \frac{n_1}{n_0} \dots \dots \dots (1)$

- Therefore, $\theta_r = 90 - \phi$

- From (1) & (3) $\sin \theta_r = \sin(90 - \phi) = \cos \phi \dots \dots \dots (3)$

$$\sin \theta_i = \frac{n_1}{n_0} \cos \phi \dots \dots \dots (4)$$



- Let $(\theta_i)_{\max}$ be the acceptance angle which occurs when $\Phi = \theta_c$

$$\sin(\theta_i)_{\max} = \frac{n_1}{n_0} \cos \theta_c \dots \dots \dots (5)$$



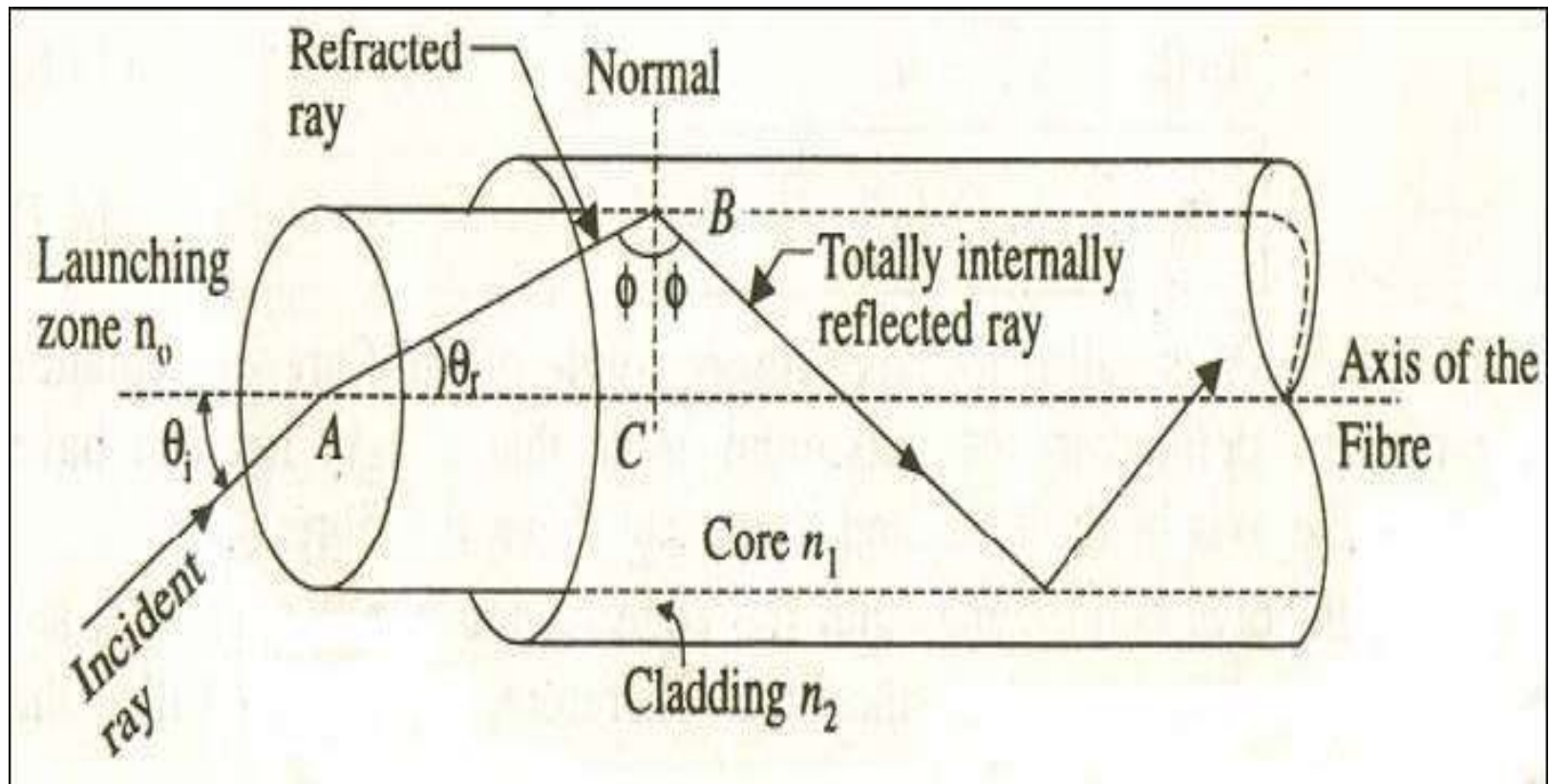

- when $\Phi = \theta_c$ then refraction angle, $r = 90$
- Therefore from snells law,

$$\frac{\sin \theta_c}{\sin 90} = \frac{n_2}{n_1}$$

$$\sin \theta_c = \frac{n_2}{n_1} \dots \dots \dots (6)$$

- Since,

$$\cos \theta_c = \sqrt{1 - (\sin \theta_c)^2}$$

$$\cos \theta_c = \sqrt{\frac{n_1^2 - n_2^2}{n_1^2}} \dots \dots \dots (7)$$

- From (5) & (7)

$$\sin(\theta_i)_{max} = \frac{n_1}{n_0} \sqrt{\frac{n_1^2 - n_2^2}{n_1^2}}$$

$$\sin(\theta_i)_{max} = \frac{\sqrt{n_1^2 - n_2^2}}{n_0} \dots \dots \dots (8)$$



NUMERICAL APERTURE:-

- Light gathering ability of a fibre is determined by using numerical aperture. This is defined as the sine of acceptance angle.

$$NA = \sin \theta_0 = \sin \left(\sin^{-1} \frac{\sqrt{n_1^2 - n_2^2}}{n_0} \right)$$

- Consider the fractional difference,
$$NA = \frac{\sqrt{n_1^2 - n_2^2}}{n_0}$$

$$\Delta = \frac{n_1 - n_2}{n_1}$$

$$\Delta = \frac{n_1 - n_2}{n_1} \times \frac{n_1 + n_2}{n_1 + n_2}$$

$$\Delta = \frac{n_1^2 - n_2^2}{n_1 \times 2n_1}$$



- Rearrange the terms

$$n_1^2 - n_2^2 = 2n_1^2\Delta$$

$$NA = \frac{n_1\sqrt{2\Delta}}{n_0}$$

- Therefore, light collecting capacity is effectively dependent on refractive indices core and cladding and not on fibre dimensions.
- If launching medium is air, then $n_0=1$.
- Then,

$$(\theta_i)_{\max} = \sin^{-1} \sqrt{n_1^2 - n_2^2} \quad NA = n_1\sqrt{2\Delta}$$

$$NA = \sqrt{n_1^2 - n_2^2}$$



TYPES OF OPTICAL FIBERS

- Depending on the refractive index of core material optical fibers are divided into two types
 - Step index fiber
 - Graded index fiber
- Depending on the mode of operation also OFC are divided in to two types
 - Mono mode fiber
 - Multi mode fiber



TYPES OF OPTICAL FIBERS:

STEP INDEX FIBER:

- These are the fibers in which the refractive index of core is maximum and constant throughout the core as

$$n(r) = n_1 \text{ for } r < a \text{ [core]}$$

$$n(r) = n_2 \text{ for } r > a \text{ [cladding]}$$

- Due to step-wise decrease of refractive index from the core n_1 to the cladding n_2 at $r=a$.
- Depending on the refractive index from core to cladding, again step index fibers are of two types.
 - Step index mono mode fiber
 - Step index multi mode fiber



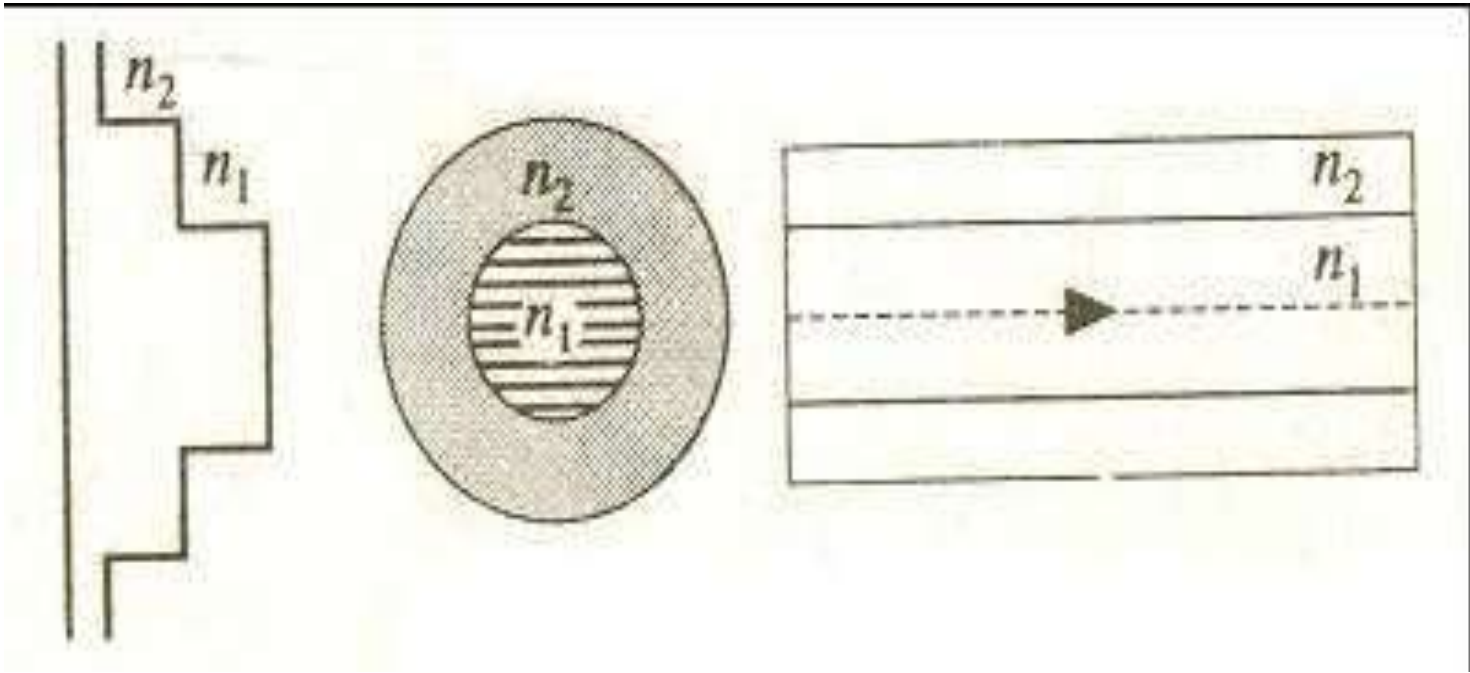

○ step index multimode fibre :

- In step index multimode fibre, the difference between μ of cladding and core is more.
- Further its core diameter is large.
- It has high attenuation and very low band width. It has high numerical aperture.
- Generally, these are used in short distant communication.

○ step index single mode fibre :

- In step index single mode fibre, the difference between μ of core and cladding is very small .
- its core diameter is also very small.
- It has low attenuation and very high band width. It has low numerical aperture.
- These are used in long distant communication.



Multi-mode Step-Index

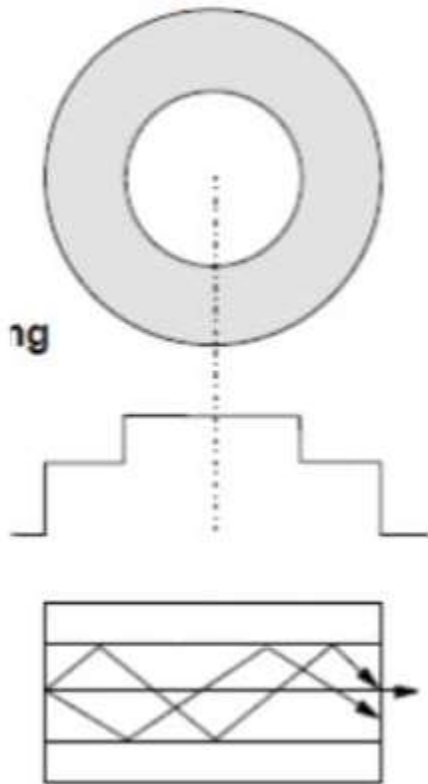

Single-mode

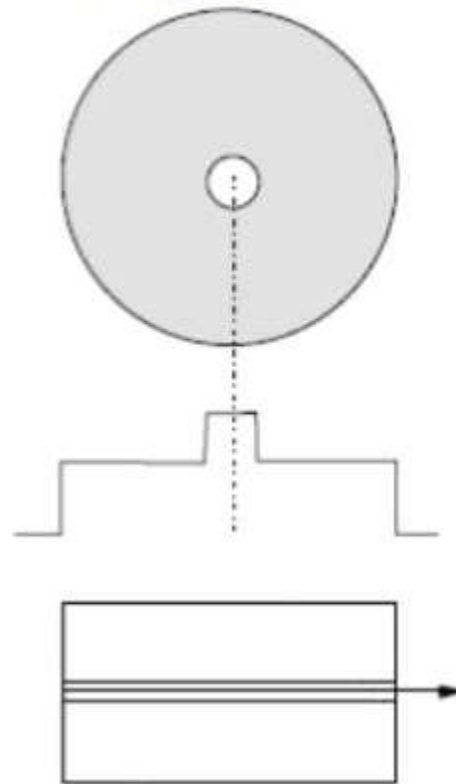

TRANSMISSION OF SIGNAL

- Let us consider the propagation of one such pulse through the multimode step index fibre. The same pulsed signal travels in different paths.

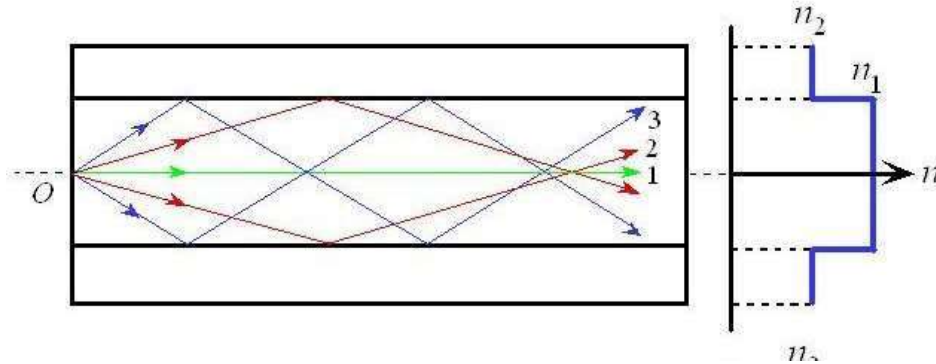

- Due to constant refractive index of core all rays will travel with same velocity.
- Hence, the rays reach the receiver end at different times. The signal received at the end gets broadened. This is called intermodal dispersion.
- Due to this, the transmission rate and capacity is reduced. This difficulty is overcome in graded index fibres.



GRADED INDEX FIBER:

- A graded index fibre is a multimode fibre with a core consisting of concentric layers of different refractive indices. That is the refractive index of the core decreases with distance from the fibre axis. It has a maximum value at centre and decreases with 'r'.

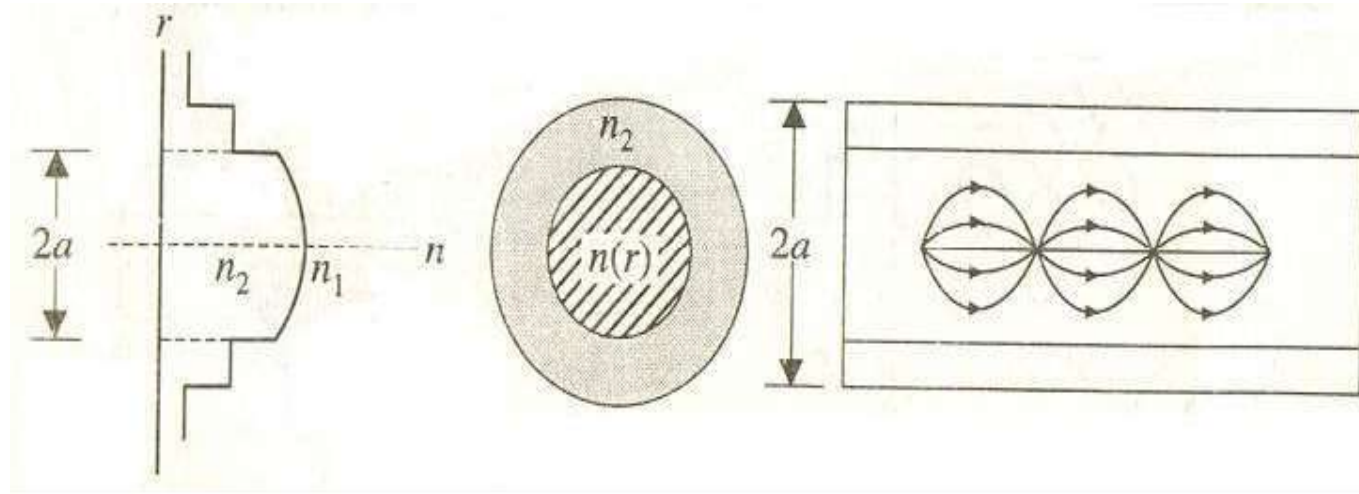

TRANSMISSION OF SIGNAL

- let us consider the propagation of one such pulse through the multimode graded index fibre. The same pulsed signal travels in different

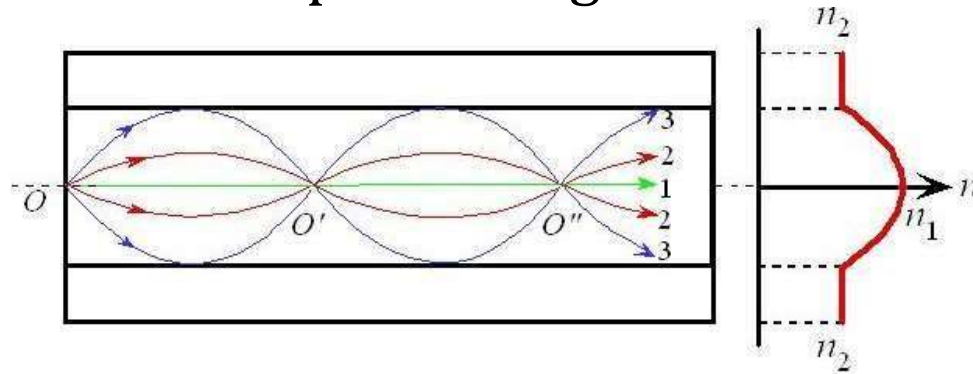

- Due to changing refractive index of core the rays will travel with different velocity.
- Hence, all pulses reach the other end simultaneously.
- Then, the problem of intermodal dispersion can be reduced to minimum in using graded index fibre.



LOSSES IN OFC (OR) ATTENUATION IN OPTICAL FIBERS:-

- The main specification of a fibre optic cable is its attenuation.
- The power of the light at the o/p end is found to be always less than the power launched at the i/p end.
- The attenuation is a function of fibre material, wavelength of light and length of the fibre.
- Losses are
 - Scattering losses
 - Absorption losses
 - Bending losses



SCATTERING LOSSES:

- Due to the variations in composition and density of the materials chosen for the core and cladding, gives rise to a variable refractive index of the material.
- Due to this light is scattered in the manner known as Rayleigh 's scattering. This scattering light is then lost from the fibre.
- The loss caused by this mechanism can be minimised by selecting proper fibre fabrication method.



ABSORPTION LOSSES:-

- Three different mechanisms contribute to absorption losses in glass fibres. There are
 - UV absorption
 - IR absorption
 - Ion resonance absorption
- In pure fused silica, absorption of UV radiation around $0.14\ \mu\text{m}$ results in ionisation. Thus, there is a loss.
- Absorption of IR photons by atoms with in glass molecules results in increase of random mechanical vibrations.
- ions are present in the material due to trapping of minute quantities of water molecules during manufacturing.



BENDING LOSSES:-

- The distortion of the fibre from the ideal straight line configuration may also result in losses in fibre. Tight bends cause some of the light not to be internally reflected but to propagate in to the cladding and be lost.
- **Loss in decibels:** Attenuation is generally measured in terms of the decibels (dB) which is a logarithmic unit. The decibel loss of optical power in a fibre is

- Attenuation loss is given by the number of decibels per kilometre of fibre.

$$\frac{\text{Loss}}{\text{Km}} = -\frac{10}{L} \log\left(\frac{P_{out}}{P_{in}}\right) \text{ dB/Km.}$$



APPLICATIONS OF OPTICAL FIBERS:-

- OFC are mainly used in three different fields
 - Fiber optic communication: The various applications of fibre optics in telecommunication area include the voice telephones, video phones, telegraph services, various new services and data networks all transmitted over common carrier links.
 - Medical application: Endoscopic applications
 - Sensor field: Various kinds of sensors have been developed. They are temperature sensors, pressure sensor, acoustic sensor, current sensor, flow meter, strain detector, chemical sensor, humidity sensor etc.



OPTICAL SENSORS

- The fiber optic sensors are classified in to two types
 - Active sensors
 - Passive sensors
- Active sensors: the physical parameters to be sensed act directly on the fiber. These are otherwise called as intrinsic sensors.
- Passive sensors: in passive sensors, separate sensing elements are used and optical fibers are used as guiding media.



PRESSURE SENSOR:

- The pressure sensor is a best example for active sensor.
- The principle behind the pressure sensor is interference, I,e., the path difference between the reference beam and the beam passing through the environment.
- High energy laser light from the source is made to fall on a beam splitter placed at a angle 45.
- The beam splitter splits incident light into two components.
- One passes through reference end and another through environment end.
- Finally the path difference between the o/p beams sense the change in pressure.



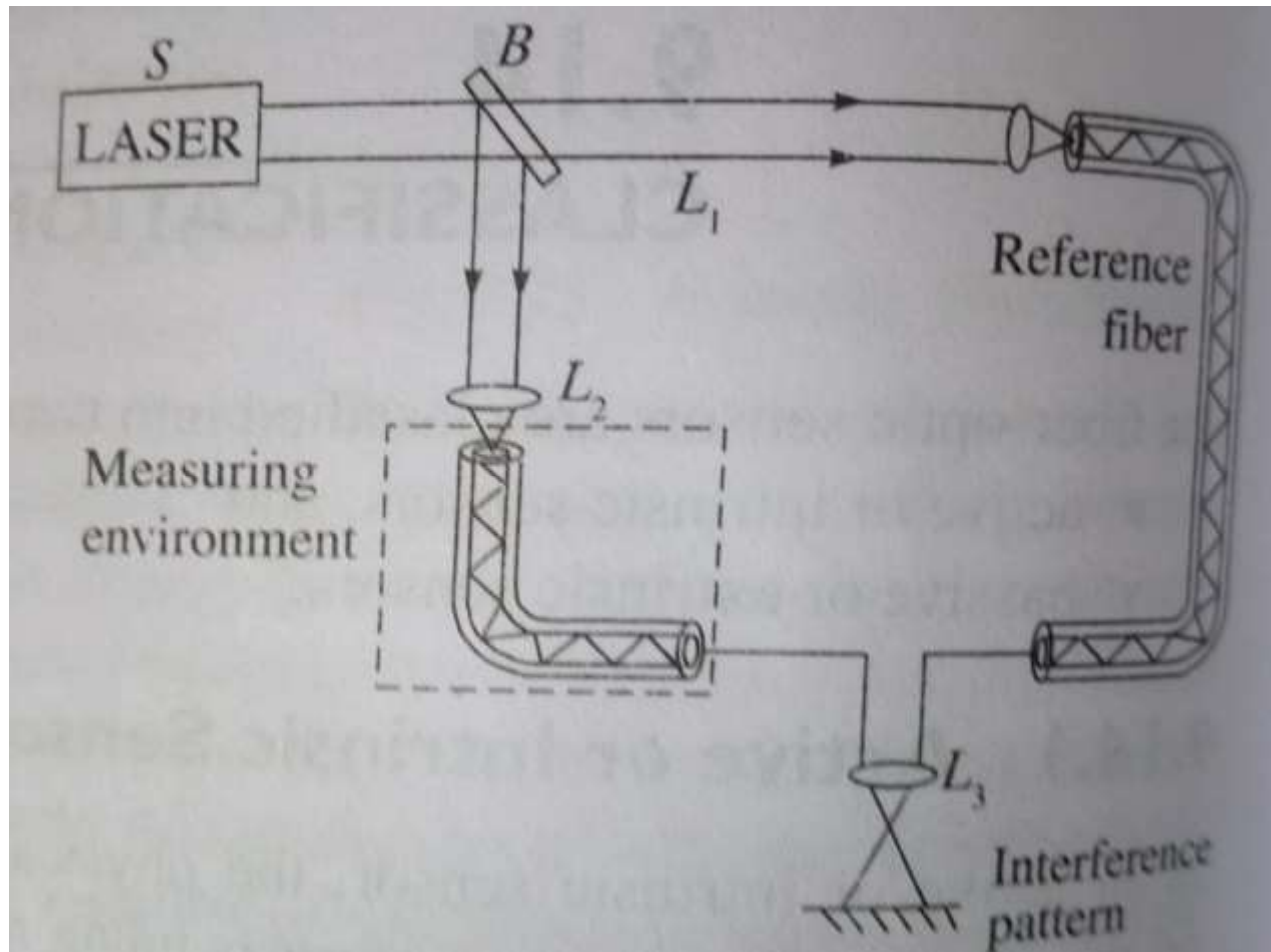

DISPLACEMENT SENSOR:

- The displacement sensor is a best example for passive sensor
- The light from the source is made to fall on the object after passing through the transmitting fiber
- The light reflected from the moving object is received by the receiving fiber and the same is detected by the detector.
- The change in the intensity of light measures the movement of the object.
- Increase intensity of light resembles that object is moving towards the sensor while decrease in intensity of light resembles that object is moving away from the sensor.



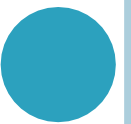
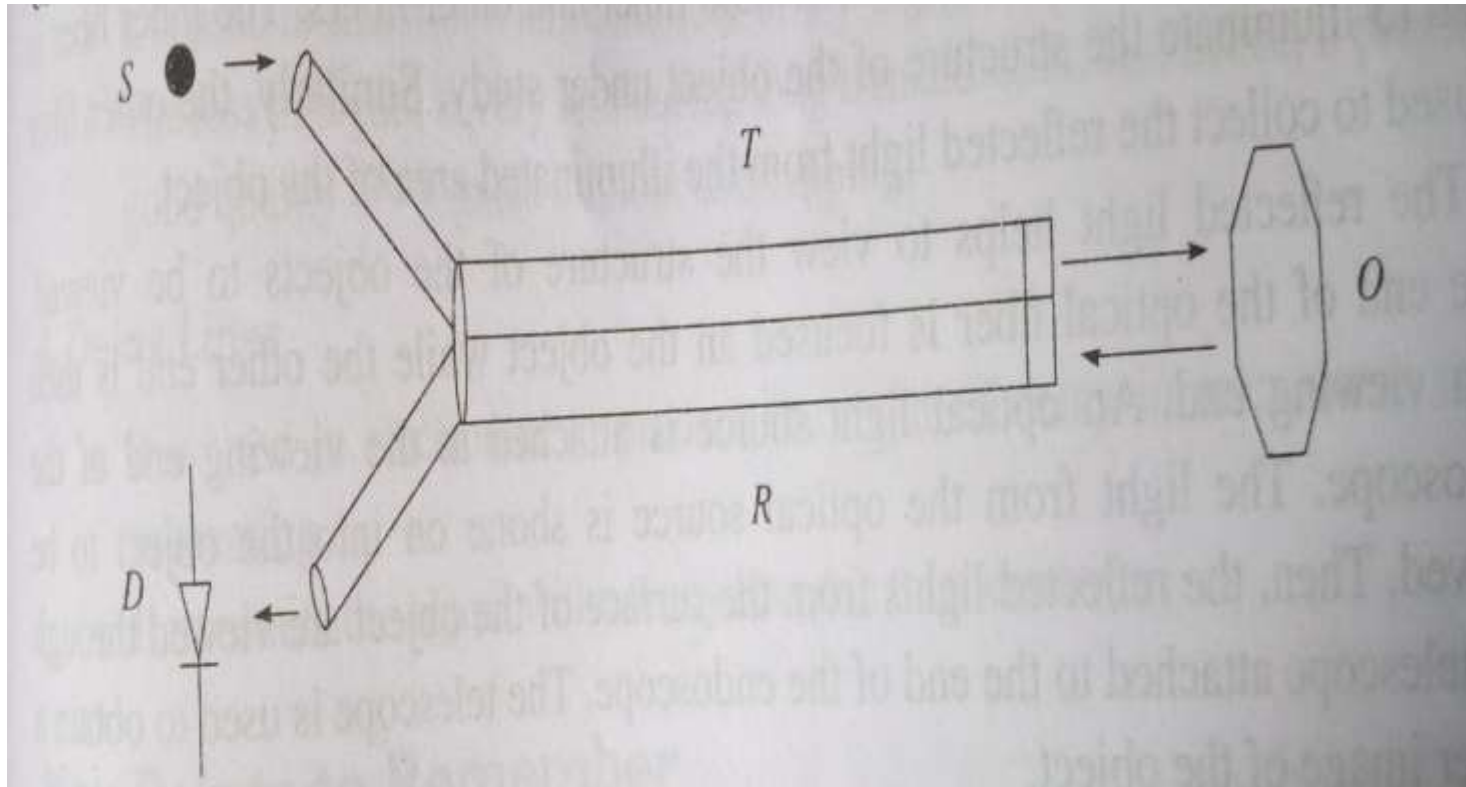

ENDOSCOPIC APPLICATIONS:

- One of the two main endoscope cables carries light from a bright lamp in the operating room into the body, illuminating the cavity where the endoscope has been inserted.
- The light bounces along the walls of the cable into the patient's body cavity.
- The diseased or injured part of the patient's body is illuminated by the light shining in.
- Light reflected off the body part travels back up a separate fiber-optic cable, bouncing off the glass walls as it goes.
- The light shines into the physician's eyepiece so he or she can see what's happening inside the patient's body. Sometimes the fiber-optic cable is directed into a video camera.



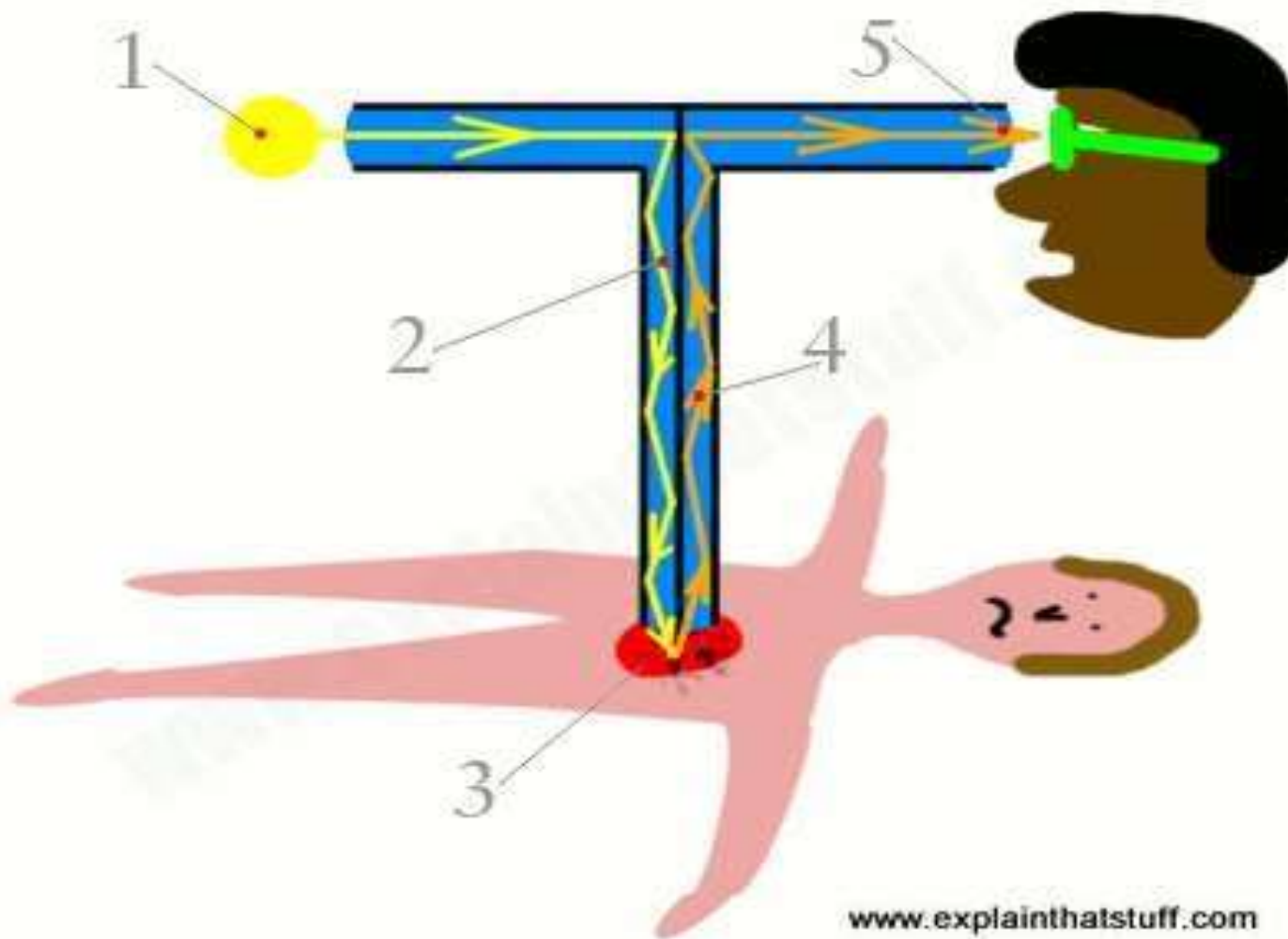

The left side of the slide features a decorative design consisting of several vertical stripes of varying shades of light blue and teal. Overlaid on these stripes are five solid teal circles of different sizes, arranged in a cluster that tapers towards the bottom.

UNIT-5

Dielectric & Magnetic Properties

- Dielectrics are the substances which do not contain free electrons or the number of such electrons is too low to constitute the electric current.
- So, the dielectric is insulating materials.
- But the insulating materials are used to resist the flow of current whereas dielectrics are used to store electrical energy.
- Dielectrics are nonmetallic materials of high specific resistance and have negative temperature coefficient of resistance.



- Comparable to conductors, the dielectrics are
 - ❖ Insulators
 - ❖ Doesn't conduct electricity
 - ❖ Charge given to them remains localized
 - ❖ For particular field strength, they lose their insulating character.



DEFINITIONS:

1. Electric field intensity: the force acting per unit test charge is defined as electric field strength or electric field intensity.

- From coulombs law,

$$F = \frac{1}{4\pi\epsilon_0} \times \frac{q_1 q_2}{r^2}$$

$$\frac{F}{q_1} = \frac{1}{4\pi\epsilon_0} \times \frac{q_2}{r^2}$$

$$E = \frac{F}{q} = \frac{1}{4\pi\epsilon_0} \times \frac{q}{r^2}$$

$$\text{generally, } E = \frac{q}{\epsilon(4\pi r^2)} = \frac{q}{\epsilon A}$$

- Units are N/C



2. Electric flux density: the number of flux lines crossing per unit surface area.

$$\text{electric flux density} = \frac{\phi}{A}$$

- Units are Wb/sq. mts

3. Electric dipole: The arrangement of two equal and opposite point charges at a fixed distance is called an electric dipole.



4. Electric dipole moment: (p) the product of charge and distance between the dipoles is called as electric dipole moment.

$$p = q \times 2l$$

○ Units are C-m

5. Polarization: the displacement of positive and negative charges by application of external electric field is called as polarization.

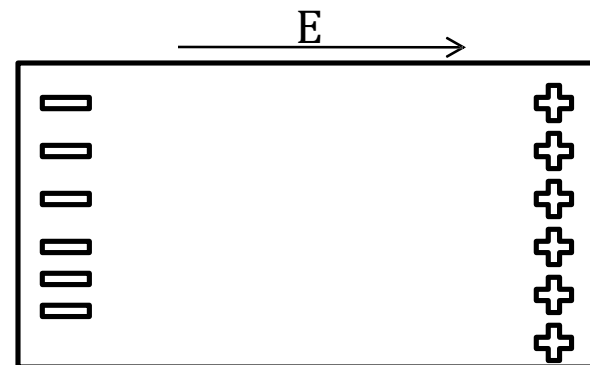
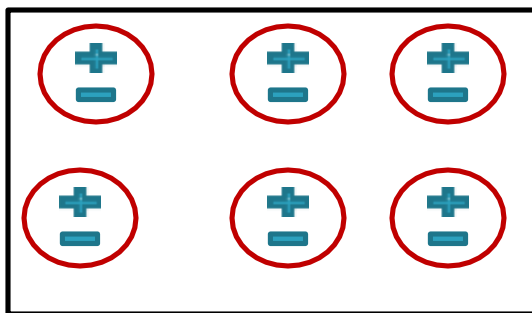

6. Polarization vector: (P) the polarization vector is defined as the ratio of induced dipole moment per unit volume.

$$P = \frac{p}{v}$$

- It is also defined as the ratio of induced charge per unit area.

- Units are C/sq. mts

$$P = \frac{q'}{A}$$



7. Polarizability: as the external field increases, dipole moment also increases.

$$p \propto E$$

$$p = \alpha E$$

- Where α is called polarizability.
- Polarizability is defined as the ratio of dipole moment per unit electric field.

$$\alpha = \frac{p}{E}$$

- Units are

$$\frac{C^2 \cdot m}{N}$$



8. Dielectric constant(K) or relative permittivity(ϵ_r)

It is defined as the ratio of permittivity of the medium to permittivity of the free space.

$$\epsilon_r = \frac{\epsilon}{\epsilon_0}$$

- There is no units for relative permittivity or dielectric constant.
- It is also defined as the ratio of capacitance of a capacitor with medium to a capacitance of a capacitor without medium.

$$K = \frac{C}{C_0}$$



9. Susceptibility: (χ)

- As the applied field increases, polarisation also increases.
There fore,

$$P \propto E$$

$$P = \chi E$$

- Where χ is called susceptibility.
- Susceptibility is defined as the ratio of polarisation vector per unit electric field.

$$\chi = \frac{P}{E}$$



10. Displacement vector:(D)

- The displacement vector is defined as the ratio of charge per unit area.

$$D = \frac{q}{A}$$

- Units are C/sq.mts



RELATION BETWEEN D, P, E

- Relation between D & E:

$$D = \frac{q}{A}$$

$$D = \frac{q}{A} \times \frac{\epsilon}{\epsilon}$$

$$D = \frac{q}{\epsilon A} \times \epsilon$$

$$\boxed{D = E \times \epsilon}$$

From relative permittivity,

$$\epsilon = \epsilon_0 \epsilon_r$$

Therefore

$$\boxed{D = E \times \epsilon_0 \epsilon_r}$$



- Relation between D, P & E:
- Consider a parallel plate capacitor with a dielectric material is placed in a external electric field.

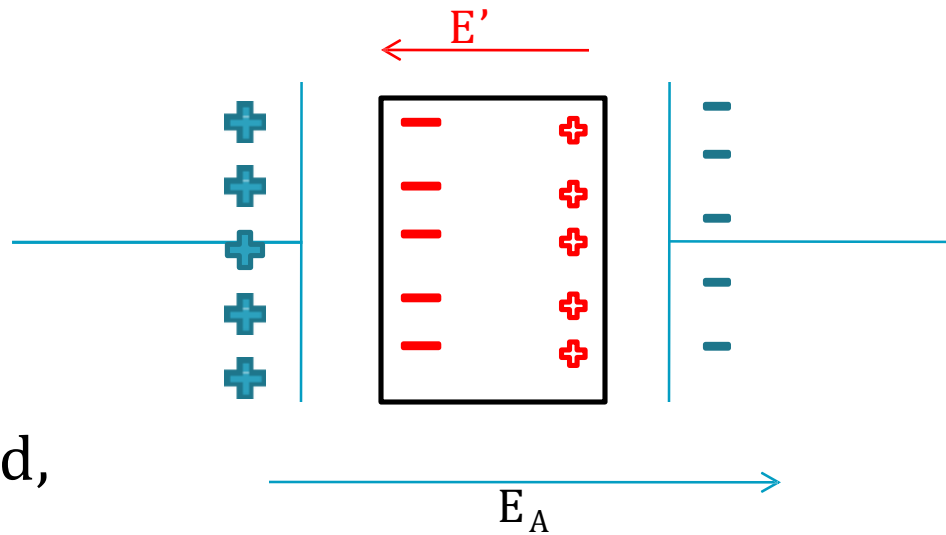

- Total field,

$$E = E_A + (-E')$$



$$E = E_A + (-E')$$

$$E = \frac{q}{\epsilon_0 A} - \frac{q'}{\epsilon_0 A}$$

$$\epsilon_0 E = \frac{q}{A} - \frac{q'}{A}$$

$$\epsilon_0 E = D - P$$

$$\boxed{D = \epsilon_0 E + P}$$



Relation between P & E:

- From the above relations,

$$D = E \times \epsilon_0 \epsilon_r$$

$$D = \epsilon_0 E + P$$

- Combining the above

$$\epsilon_0 \epsilon_r E = \epsilon_0 E + P$$

$$\epsilon_0 \epsilon_r E - \epsilon_0 E = P$$

$$P = (\epsilon_r - 1)\epsilon_0 E$$



Relation between χ & ϵ_r

- From above relation

$$P = (\epsilon_r - 1)\epsilon_0 E$$

- Susceptibility,

$$P = \chi E$$

- Comparing above two equations,

$$\chi = (\epsilon_r - 1)\epsilon_0$$



TYPES OF POLARIZATION:

There are three mechanisms by which polarization can occur in dielectric materials when they are subjected to an external electric field.

They are

- Electronic polarization
- Ionic polarization
- Orientation polarization.



Electronic polarization:

- ❖ On the application of electric field, the displacement of positively charged nucleus and negatively charged electrons of an atom of radius R in opposite directions, results in electronic polarization.
- ❖ Since the nucleus and centre of electron cloud are separated, the dipole moment is created in each atom.
- ❖ Therefore induced dipole moment is directly proportional to applied electric field

$$p_e \propto E$$

$$p_e = \alpha_e E$$

- ❖ Where $\alpha_e = 4\pi\epsilon_0 R^3$ is called electronic polarizability



CONCLUSION:

- Electronic polarization is independent of temperature.
- It is proportional to the volume of atoms in the material
- Electronic polarization takes place in all dielectrics



Ionic polarization:

- ❑ This type of polarization occurs only in ionic bonded dielectric materials such as NaCl.
- ❑ When such materials are subjected to external electric field, the adjacent ions of opposite sign undergo displacement.
- ❑ Hence ionic polarization is due to displacement of cations of mass m and anions of mass M in opposite direction.
- ❑ Therefore induced dipole moment is directly proportional to applied electric field

$$p_i \propto E$$

$$p_i = \alpha_i E$$

- ❑ Where $\alpha_i = \frac{e^2}{\omega_0^2} \left[\frac{1}{m} + \frac{1}{M} \right]$ is called ionic polarizability.



Orientation polarization:

- Polar dielectrics exhibit orientation polarization
- When an external field is applied to polar dielectrics, they tend to align themselves in the direction of external electric field.
- The polarization due to such alignment is called orientation polarization.
- Therefore induced dipole moment is directly proportional to applied electric field

$$p_o \propto E$$

$$p_o = \alpha_o E$$

- Where $\alpha_o = \frac{\mu^2}{3KT}$ is called orientation polarizability
- Orientation polarization depends on temperature.



Space charge polarization:

- The space charge polarization occurs due to diffusion of ions, along the field direction and giving rise to redistribution of charges in the dielectrics.



TOTAL ELECTRIC POLARIZATION

- The Total Electric polarization is the sum of electronic polarization, ionic polarization, orientation polarization, and space charge polarization.
- Among these, the space charge polarization is very small compared to others. So it can be neglected
- Therefore the total polarizability is given by

$$\alpha = \alpha_e + \alpha_i + \alpha_0$$



- Where,

$$\alpha_e = 4\pi\epsilon_0 R^3$$

$$\alpha_i = \frac{e^2}{\omega_0^2} \left[\frac{1}{m} + \frac{1}{M} \right]$$

$$\alpha_o = \frac{\mu^2}{3KT}$$

- Therefore,

$$\alpha = 4\pi\epsilon_0 r^3 + \left(\frac{e^2}{\omega_0^2} \left(\frac{1}{m} + \frac{1}{M} \right) \right) + \frac{\mu^2}{3KT}$$

- We know that the total polarization is

$$P = N\alpha E$$

$$P = N \left(4\pi\epsilon_0 r^3 + \left(\frac{e^2}{\omega_0^2} \left(\frac{1}{m} + \frac{1}{M} \right) \right) + \frac{\mu^2}{3KT} \right) E$$

- This equation is called Langevin- Debye equation



POLAR AND NON-POLAR MOLECULES

- The molecules in which the center of gravity due to positive and negative charges coincides are called non polar molecules otherwise polar molecules.
- For non-polar molecules (H_2 , N_2 , O_2 , CO_2 , BENZENE), the dipole moment is zero and they have symmetrical structure.
- For polar molecules (H_2O , HCl , CO , N_2O , NH_3), the dipole moment is permanent and they have unsymmetrical structure.



INTERNAL FIELD OF A DIELECTRIC SOLID:

- In solids, the atoms are very close to each other and interact considerably.
- When an electric field is applied, the atoms are polarized.
- Each of the atoms develops a dipole moment. i.e., each atom acts as dipole.
- Therefore, electric field at any given atom is the sum of applied electric field plus the electric field due to surrounding dipoles.
- This resultant local field is called as internal field.



DERIVATION:

- Consider a solid dielectric be placed between the plates of a parallel plate capacitor.
- let there be an imaginary spherical cavity around the atom a inside the dielectric.
- It is also assumed that the radius of the cavity is large compared to the radius of the atom.
- The internal field at the atom site A is given by

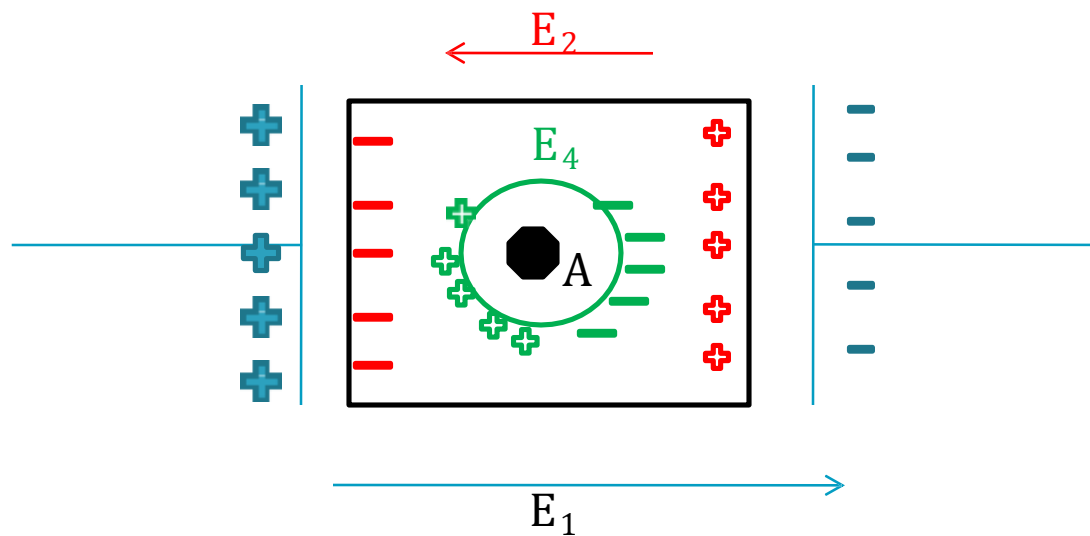

E_1 field:

- E_1 is the field intensity at A due to the charge density on the plates.

$$E_1 = \frac{D}{\epsilon_0}$$

since,

$$D = P + \epsilon_0 E$$

Therefore,

$$E_1 = \frac{P + \epsilon_0 E}{\epsilon_0}$$

$$E_1 = \frac{P}{\epsilon_0} + E$$



E_2 field:

- E_2 is the field intensity at a due to the charge density induced on the two sides of the dielectric.

$$E_2 = -\frac{P}{\epsilon_0}$$

E_3 field:

- It is the field due to other atoms contained in the cavity. Since it is a cubic structure, due to symmetry $E_3=0$.



E_4 field:

- It is the field due to polarization charges on the surface of the cavity and was calculated by Lorentz.

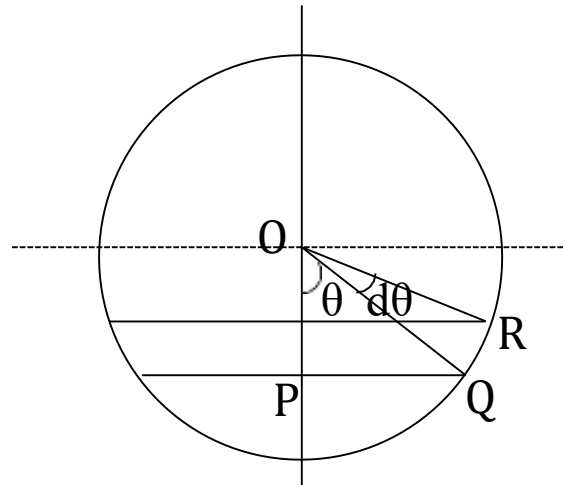

- If dA is the surface area of the sphere of radius r lying between θ and $\theta+d\theta$. then,

$$dA=2\pi(PQ)(QR)$$

- Since, $PQ=r \sin \theta$, from right angle triangle OPQ
 $QR=r d\theta$, from triangle OQR

- Therefore, $dA=2\pi r^2 \sin \theta d\theta$

- The charge on the surface dA is

$$\begin{aligned}dq &= P \cos\theta \, dA \\ &= P 2\pi r^2 \sin\theta \cos\theta \, d\theta \\ &= P\pi r^2 \sin 2\theta \, d\theta\end{aligned}$$

Since, $P=q/A$, then $q=PA$. as the field is moving horizontally, the horizontal component of charge is $q=(P \cos\theta)A$

- Therefore,

$$\begin{aligned}dE_4 &= \frac{dq \times 1 \times \cos\theta}{4\pi\epsilon_0 r^2} \\ &= \frac{P}{4\epsilon_0} \cos\theta \sin 2\theta \, d\theta\end{aligned}$$



○ So,

$$E_4 = \int dE_4$$

$$= \frac{P}{4\epsilon_0} \int \cos\theta \sin 2\theta \, d\theta$$

$$\sin 2\theta = 2 \cos\theta \sin\theta$$

$$= \frac{P}{2\epsilon_0} \int \cos^2\theta \sin\theta \, d\theta$$

$$\text{Since, } d(\cos\theta) = -\sin\theta \, d\theta.$$

$$\text{Then } \sin\theta \, d\theta = d(-\cos\theta)$$

$$= \frac{P}{2\epsilon_0} \int \cos^2\theta \, d(-\cos\theta)$$

$$= -\frac{P}{2\epsilon_0} \frac{\cos^3\theta}{3} \Big|_{\text{limits extending from } 0 \text{ to } \pi}$$

$$= -\frac{P}{6\epsilon_0} [-1 - 1]$$

$$= \frac{P}{3\epsilon_0}$$



- Therefore internal field,

$$E_i = E_1 + E_2 + E_3 + E_4$$

$$E_i = E + \frac{P}{\epsilon_0} - \frac{P}{\epsilon_0} + 0 + \frac{P}{3\epsilon_0}$$

$$E_i = E + \frac{P}{3\epsilon_0}$$



CLASSIUS-MOSOTTI RELATION:

- Consider a dielectric having cubic structure with N atoms.

$$P = \alpha_{\epsilon} N E_i = \alpha_{\epsilon} N \left[E + \frac{P}{3\epsilon_0} \right]$$

$$P \left[1 - \frac{\alpha_{\epsilon} N}{3\epsilon_0} \right] = [\alpha_{\epsilon} N E]$$

$$P = \frac{[\alpha_{\epsilon} N E]}{\left[1 - \frac{\alpha_{\epsilon} N}{3\epsilon_0} \right]}$$

- We know that

$$\epsilon_0 E (\epsilon_r - 1) = P$$

$$\epsilon_0 E (\epsilon_r - 1) = \frac{[\alpha_{\epsilon} N E]}{\left[1 - \frac{\alpha_{\epsilon} N}{3\epsilon_0} \right]}$$



$$1 - \frac{\alpha_e N}{3\epsilon_0} = \frac{[\alpha_e N]}{[\epsilon_0(\epsilon_r - 1)]}$$

$$1 = \frac{\alpha_e N}{3\epsilon_0} + \frac{[\alpha_e N]}{[\epsilon_0(\epsilon_r - 1)]}$$

$$1 = \frac{\alpha_e N}{3\epsilon_0} \left[1 + \frac{3}{[\epsilon_r - 1]} \right]$$

$$\frac{\alpha_e N}{3\epsilon_0} = \frac{1}{1 + \frac{3}{[\epsilon_r - 1]}}$$

$$\frac{\alpha_e N}{3\epsilon_0} = \frac{\epsilon_r - 1}{\epsilon_r + 2}$$

- This is called Clausius-Mosotti relation.



DEFINITIONS

1. MAGNETIC FIELD INTENSITY: (H)

- ❖ The magnetic field intensity (H) at any point in the magnetic field is the force experienced by an unit north pole placed at that point.
- ❖ Units are A/m

2. MAGNETIC FIELD INDUCTION: (B)

- ❖ The magnetic field induction (B) or magnetic flux density in any material is the no.of lines of magnetic force passing through unit area perpendicularly.

$$B = \frac{\phi}{A}$$

- ❖ Units are Wb/m² or Tesla



3. Magnetic dipole:

- ❖ The arrangement of any two opposite poles separated by certain distance is called as magnetic dipole.

4. magnetic dipole moment: (M)

- ❖ The product of magnetic pole strength with length of the magnet is called magnetic dipole moment.

$$M = m \times 2l$$

- ❖ Units are A-sq.mts



5. Magnetisation: (I)

- ❖ The magnetic moment per unit volume of the substance is called as intensity of magnetization or magnetisation.

$$I = \frac{M}{V}$$

- ❖ Units are A/m

6. MAGNETIC SUSCEPTIBILITY: (χ)

- ❖ It is defined as the ratio of intensity of magnetization I to magnetic intensity H.

$$\chi = \frac{I}{H}$$

- ❖ It has no units.



Z. PERMEABILITY:

- ❖ The magnetic induction B and intensity H are related by

$$B = \mu_0 H$$

- ❖ Where μ_0 is permeability of free space $= 4\pi \times 10^{-7}$ H/m

- ❖ For a medium

$$B = \mu H$$

- ❖ Where $\mu = B/H$ is called as permeability.
- ❖ Permeability is defined as the ratio of magnetic induction in the sample to the applied magnetic field intensity.
- ❖ Units are H/m.



8. Relative permeability:

- ❖ It is defined as the ratio of permeability of medium to permeability of free space.

$$\mu_r = \frac{\mu}{\mu_0}$$

- ❖ There is no units for relative permeability.

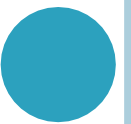

RELATION BETWEEN B, H & I:

❖ For a medium

$$B = \mu H$$

❖ Since,

$$\mu_r = \frac{\mu}{\mu_0}$$

$$B = \mu_0 \mu_r H$$

$$B = \mu_0 \mu_r H + \mu_0 H - \mu_0 H$$

$$B = \mu_0 H (\mu_r - 1) + \mu_0 H \quad \text{since, } I = H(\mu_r - 1)$$

$$\boxed{B = \mu_0 (H + I)}$$

❖ Where I is magnetisation.



Relation between μ_r & χ

❖ Relative permeability is given by

❖ Since

$$\mu_r = \frac{\mu}{\mu_0}$$

$$\boxed{B = \mu_0(H + I)}$$

❖ Therefore,

$$\mu_0 = \frac{B}{H + I}$$

$$\mu_r = \frac{\frac{B}{H}}{\frac{B}{H + I}} = \frac{H + I}{H} = 1 + \frac{I}{H} = 1 + \chi$$

$$\boxed{\mu_r - 1 = \chi}$$



ORIGIN OF MAGNETIC MOMENT:

An electron revolving in an orbit about the nucleus of an atom is a minute current loop and produces a magnetic field. It thus behaves like a magnetic dipole. Let us calculate its magnetic moment.

- Let us consider an electron of mass 'm' and charge 'e' moving with speed 'v' in a circular bohr orbit of radius r. it constitutes a current of magnitude,

$$i = \frac{e}{T}$$

Where T is the orbital period of the electron.

- Now,

$$T = \frac{2\pi r}{v}$$

- So,

$$i = \frac{ev}{2\pi r}$$



- From electromagnetic theory, the orbital magnetic dipole moment magnitude for a current I in loop of area A is

$$\mu_L = iA = \frac{ev}{2\pi r} \pi r^2 = \frac{evr}{2}$$

- The orbital angular momentum is given by

$$l = mvr$$
$$\frac{\mu_L}{L} = \frac{e}{2m}$$

- The $(e/2m)$ ratio is called **gyro magnetic ratio**.

- In vector form, $\vec{\mu}_L = -\left(\frac{e}{2m}\right)\vec{L}$

- Where minus indicates they are in opposite direction. Units of magnetic dipole moment is amp-m² or J/T.



BOHR MAGNETON:

- From wave mechanics, the permitted values of L are

$$L = \sqrt{L(L + 1)} \frac{h}{2\pi}$$

Where l is orbital quantum number.

- So, orbital magnetic moment is

$$\begin{aligned}\mu_L &= L \frac{e}{2m} \\ &= \sqrt{L(L + 1)} \frac{eh}{4\pi m}\end{aligned}$$

- The quantity $[eh/4\pi m]$ is called the 'Bohr magneton' denoted by μ_B . where $\mu_B = 9.28 \times 10^{-24} \text{ A}\cdot\text{m}^2$.
- Thus,

$$\mu_L = \sqrt{L(L + 1)} \mu_B$$



MAGNETIC MATERIALS

- ❖ Magnetic materials are those substances which get magnetized when placed in a magnetic field.
- ❖ So, the substance develop magnetization which may be parallel or antiparallel to the applied field.
- ❖ Depending upon the magnitude and sign of response to the applied field, and also on the basis of temperature on the magnetic properties, all materials are classified as follows.
 - ❖ Diamagnetic materials
 - ❖ paramagnetic materials
 - ❖ ferromagnetic materials
 - ❖ antiferromagnetic materials
 - ❖ ferrimagnetic materials



- ❖ Materials which are lack of permanent dipoles are called **diamagnetic**.
- ❖ If the atoms of the material carry permanent magnetic dipoles and they do not interact among themselves then the materials are called **Paramagnetic**
- ❖ If the atoms of the material carry permanent magnetic dipoles and they interact and line up themselves in parallel, then the materials are called **Ferromagnetic**
- ❖ If the atoms of the material carry permanent magnetic dipoles and they interact and line up themselves in anti-parallel with equal magnitude, then the materials are called **Anti-Ferromagnetic**
- ❖ If the atoms of the material carry permanent magnetic dipoles and they interact and line up themselves in anti-parallel with unequal magnitude, then the materials are called **Ferrimagnetic**

Diamagnetic:

- The substance which when placed in the magnetic field acquire feeble magnetism opposite to the direction of the field are known as dia magnetic substances.
- Eg: bismuth (Bi), zinc (Zn), copper (Cu), silver (Ag), gold (Au)

Properties:

- Diamagnetism occurs in those materials which doesn't have permanent dipoles and do not poses any net magnetic moment
- when a bar of dia-magnetic material is suspended freely between two magnetic poles, then the longest axis of the bar becomes perpendicular to magnetic field.

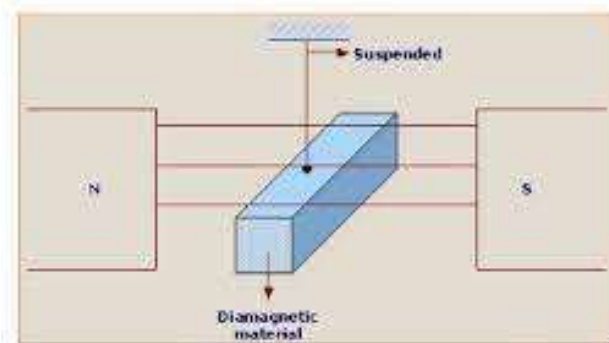

- Permeability μ less than one ($\mu < 1$) and susceptibility (χ) is negative.
- When U-tube containing diamagnetic liquid is placed in magnetic field then it shows depression.

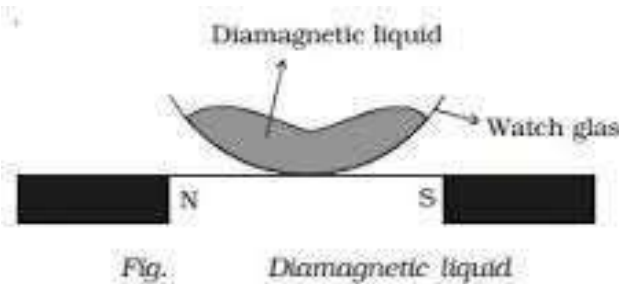

- When a dia magnetic substance is placed in non uniform magnetic field then it tends to move from stronger part to the weaker part of the field.
- Magnetic lines of force does't prefer to pass through a diamagnetic substance.

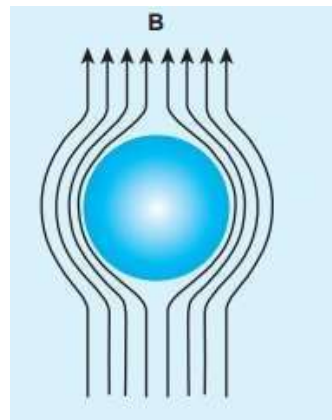

- Susceptibility of diamagnetic materials are independent of temperature.
- Example: organic materials



Paramagnetic:

- The substance which when placed in a magnetic field, acquire feeble magnetism in the direction of magnetic field are known as paramagnetic substance.
- Eg: aluminum (Al), platinum (Pt), manganese (Mn), oxygen (O_2).

Properties:

- Paramagnetism occur in those materials in which permanent dipoles exist and posses net magnetic moment.
- When a bar of paramagnetic substance is suspended freely between two magnetic poles, its axis becomes parallel to magnetic field.

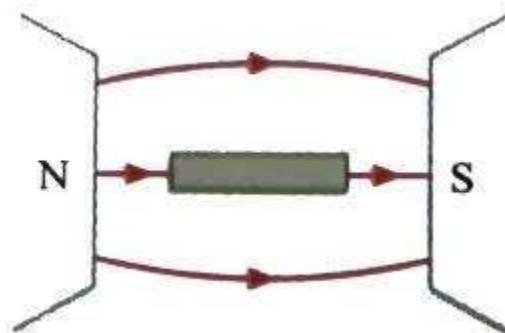

- When a bar of paramagnetic substance is placed in a magnetic field, it tries to concentrate the lines of force into it.



- Permeability is greater than one ($\mu > 1$) and susceptibility (χ) is small & positive.
- When U-tube containing paramagnetic liquid is placed in magnetic field then it shows a rise.

Paramagnetic liquid or powder

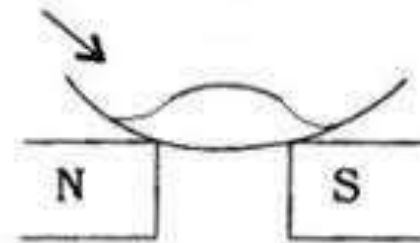

- When a para magnetic substance is placed in non uniform magnetic field then it tends to move from weaker part to the stronger part of the field.
- Susceptibility of paramagnetic materials dependent on temperature.

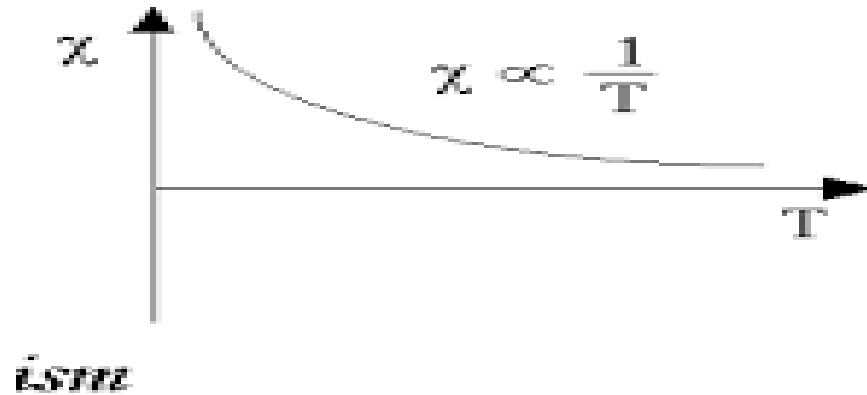

- Examples: alkali metals



Ferromagnetic:

- The substance which when placed in magnetic field, becomes strongly magnetized in the direction of field are known as ferromagnetic materials.
- Examples: iron(Fe), nickel(Ni), cobalt(Co)

Properties:

- Ferromagnetism occurs in those materials in which atoms have permanent dipoles and possess net magnetic moment.
- When a bar of ferromagnetic substance is suspended freely between two magnetic poles, its axis becomes parallel to magnetic field

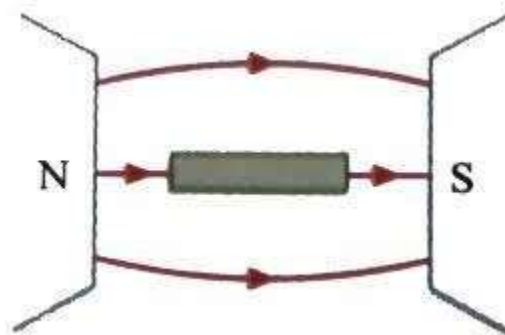

- When a bar of ferromagnetic substance is placed in a magnetic field, it tries to concentrate the lines of force into it.



- Permeability is much greater than one ($\mu \gg 1$) and susceptibility (χ) is high & positive.
- When U-tube containing ferro magnetic liquid is placed in magnetic field then it shows a rise.

Paramagnetic liquid or powder

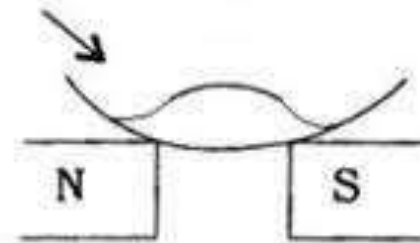

- When a ferro magnetic substance is placed in non uniform magnetic field then it tends to move from weaker part to the stronger part of the field.
- Susceptibility of ferromagnetic materials dependent on temperature.

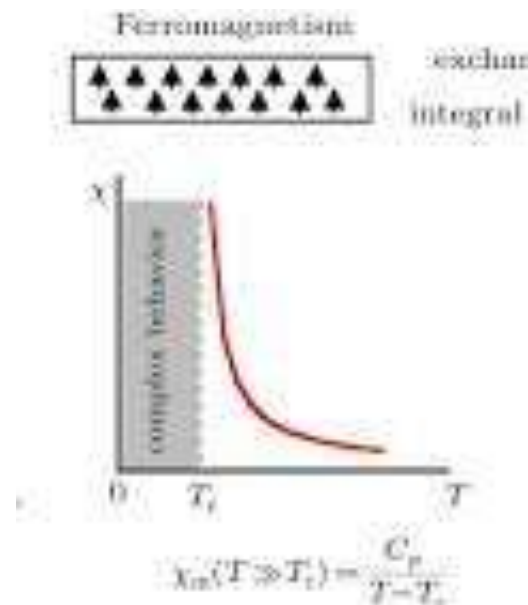

- Examples: rare earth metals



Anti ferro magnetic materials:

- This magnetism occurs in those materials in which atoms are very close to each other and poses permanent magnetic dipoles.
- Due to antiparallel equal magnitude spins, the resultant magnetic effect is zero.
- Electron spins of atoms are alligned anti parallel with equal magnitude
- Magnetic permeability is positive and very high.
- Magnetic susceptibility is positive and very small.
- Susceptibility depends on temperature.
- Examples : salta of transition elements.

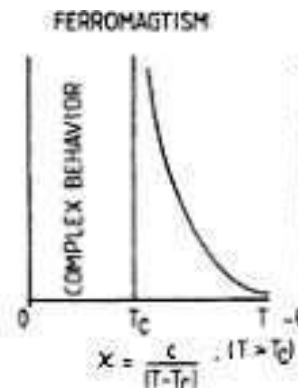

Ferri magnetic materials:

- This magnetism occurs in those materials which possess permanent magnetic dipoles.
- Due to parallel, equal magnitude spins, the resultant magnetic effect is along the direction of applied field.
- Electron spins of atoms are aligned anti parallel with unequal magnitude
- Magnetic permeability is positive and very high.
- Magnetic susceptibility is positive and very large.
- Susceptibility depends on temperature.
- Examples : ferrites

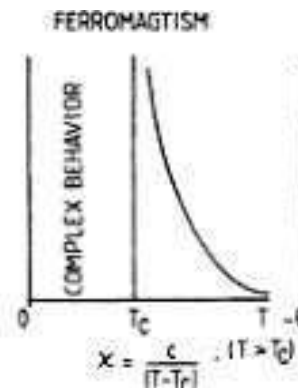

S.No.	Diamagnetic material	Paramagnetic material	Ferromagnetic material	Antiferromagnetic material	Ferrimagnetic material
1.	Net magnetic moment exists in the presence of magnetic field in opposite direction.	Net magnetic moment exists in the direction of applied magnetic field.	Large net magnetic moment exists in the direction of applied magnetic field.	Net magnetic moment exists in the direction of applied magnetic field.	Net large magnetic moment exists in the direction of applied magnetic field.
2.	There is an induced magnetism opposite to applied field.	There is an induced magnetism in the direction of the field.	There is strong induced magnetism in the direction of the field.	There is an induced magnetism in the direction of the field.	There is a large induced magnetism in the direction of the field.
3.	It repels the magnetic lines of forces due to the external magnetic field.	It allows the magnetic lines of forces to pass through it.	It allows a large number of magnetic lines of forces to pass through it.	It allows magnetic lines of forces to pass through it.	It allows large number of lines of forces to pass through it.
4.	Relative permeability $\mu_r < 1$	$\mu_r > 1$	$\mu_r \gg 1$	$\mu_r > 1$	$\mu_r \gg 1$
5.	Since the induced magnetic moment is opposite to the direction of the applied field, the intensity of magnetization ' M ' is negative.	Since the induced magnetic moment is in the direction of applied field, intensity of magnetization ' M ' is positive and moderate.	Intensity of magnetization ' M ' is +ve and high, since large magnetic moment is induced in the direction of the field.	Intensity of magnetization ' M ' is positive and moderate.	Intensity of magnetization ' M ' is positive and high.
6.	Susceptibility ' χ ' is negative.	' χ ' is low and positive.	' χ ' is high and positive.	' χ ' is low and positive.	' χ ' is high and positive.
7.	Susceptibility χ is independent of temperature.	$\chi = \frac{C}{T}$ which is Curie law where C = Curie const.	$\chi = \frac{C}{T \pm T_c}$ which is Curie-Weiss law where T_c = Curie temperature.	$\chi = \frac{C}{T + T_c}$	$\chi = \frac{C}{T \pm T_c}$
8.	Examples: organic materials.	Examples: Alkali metals and transition metals.	Examples: Transition and rare earth metals.	Examples: Salts of transition elements.	Examples: Ferrites.

DOMAIN THEORY OF FERROMAGNETISM ON THE BASIS OF HYSTERESIS CURVE:

- ❖ In Ferro magnetic substances, the atoms due to certain mutual interaction, form innumerable small effective regions called **domains**.
- ❖ When a ferromagnetic substance is placed in an external magnetic field, the magnetic moment increase in two different ways:
 - ❖ ***By the displacement of the boundaries of the domains:***
 - ❖ When the substance is placed in magnetic field, the domains which are oriented favourable with respect to the external field increases in size while those oriented opposite to the external field are reduced.



❖ *By the rotation of domains:*

- ❖ The domains rotate until their magnetic moment aligned more or less in the direction of external magnetic field.
- ❖ When external field is weak, the substance is magnetized mostly by the boundary displacement. On the other hand, in strong magnetic fields, the magnetization takes place mostly by the rotation of domains.
- ❖ On the removal of external field, the boundaries do not move completely back to their original position and hence the substance is not completely demagnetized. At high temperatures, the domains break up and ferromagnetic substance becomes paramagnetic.



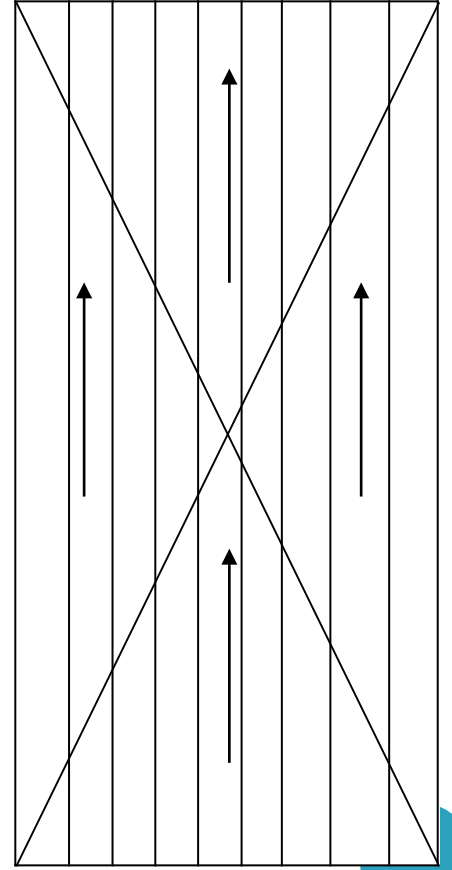
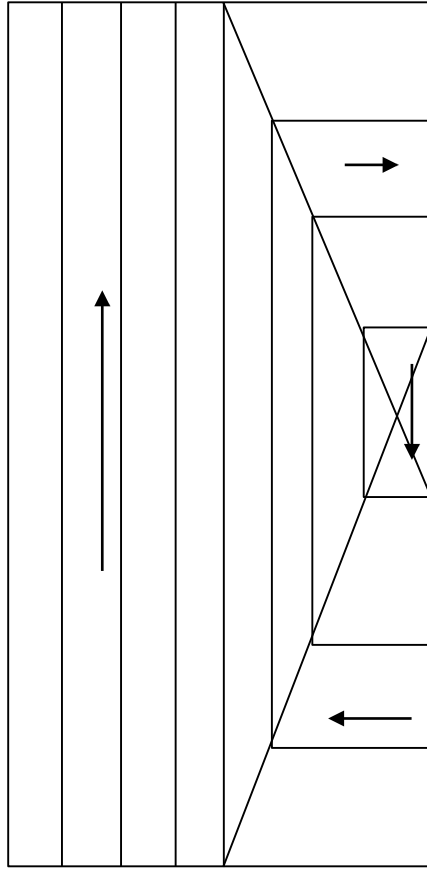
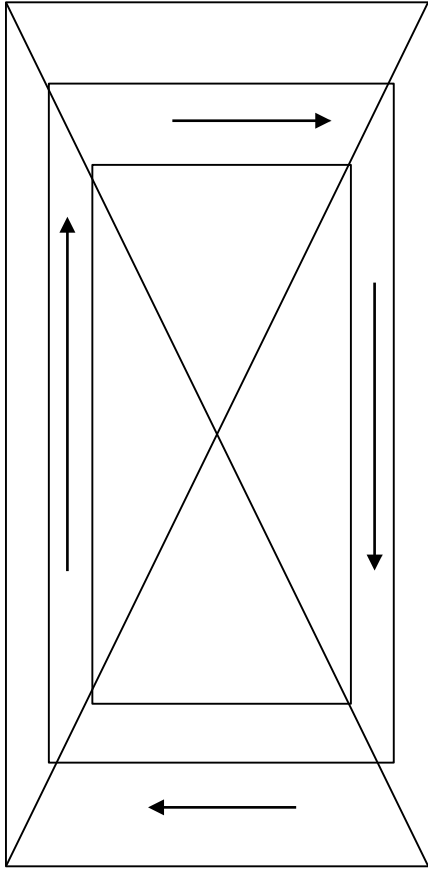

HYSTERESIS CURVE:

- Consider an unmagnified ferromagnetic substances in a magnetizing field. The substance shows a relation between magnetic flux density and strength of magnetic field. This property is called hysteresis.
- When a substances is slowly magnetized, the flux density B increases with field H . As part OA .
- At point A , the flux density B becomes constant. That is the state of magnetic saturation.
- Now, consider that magnetizing field H is decreased, B also decreases but it doesn't follows the path AO . It follows the path AB . At point B , flux density has some value even $H=0$. The value of B for which $H=0$ is called retentivity or residual magnetism.



- Further consider the direction of H is reversed. As H increases in reverse direction, B decreases and becomes zero. The value of magnetizing field for which residual magnetism is destroyed is called coercivity. Further increase of H in reverse direction gives saturation point D .
- If now the field is increased in steps, a curve $DEFA$ is obtained. In throughout the cycle, B lags behind H . thus, lagging of magnetization behind the magnetic field is called hysteresis and path $ABCDEFA$ is called hysteresis loop.



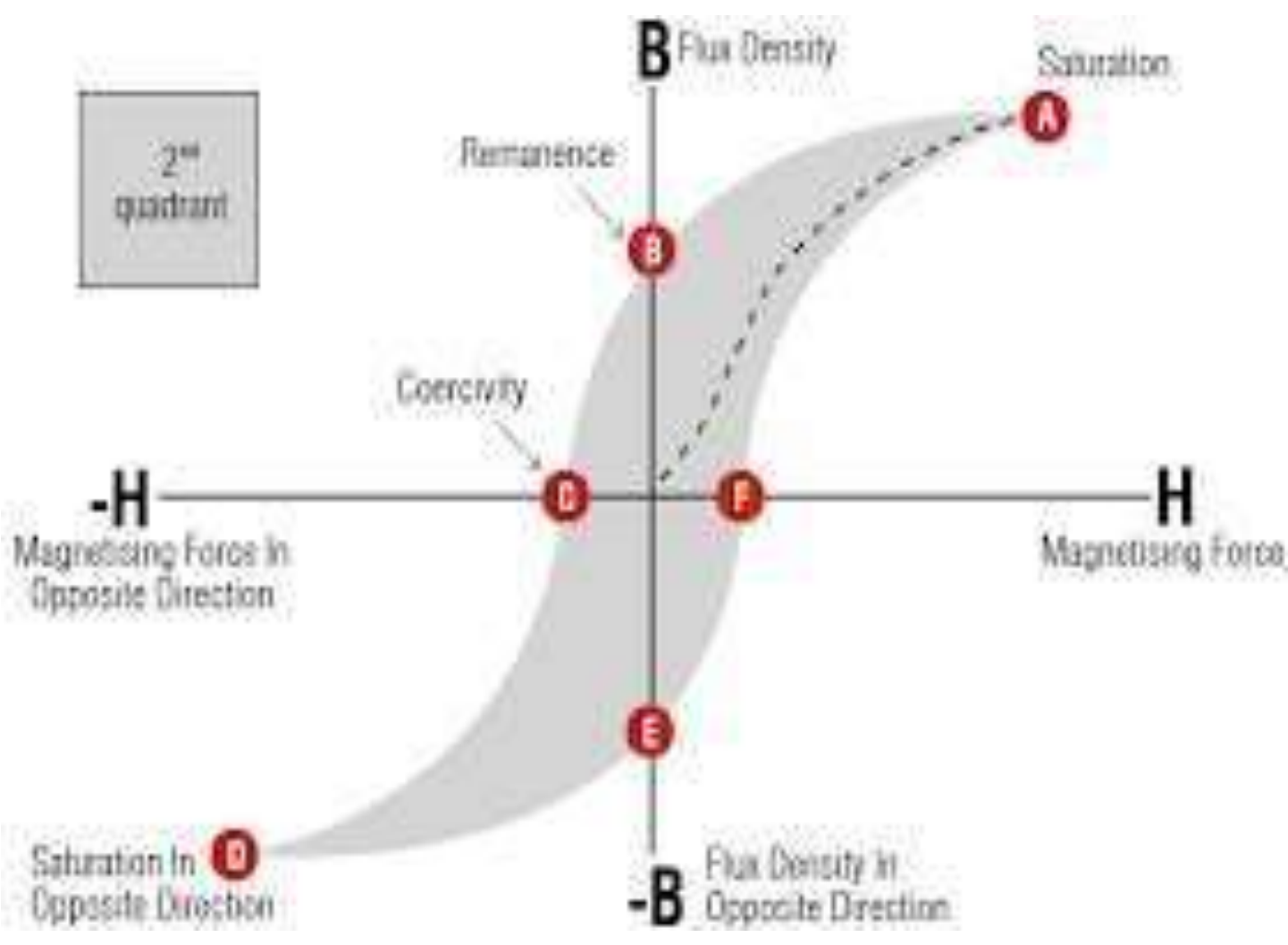

SOFT AND HARD MAGNETIC MATERIALS:

Hard magnetic materials	Soft magnetic materials
Hard magnetic materials are those which are difficult to magnetize and demagnetize.	Soft magnetic materials are those which are easy to magnetize and demagnetize.
These materials have large hysteresis loss due to large hysteresis loop area.	These materials have less hysteresis loss due small hysteresis loop area.
In these materials domain wall movement is difficult.	In these domain walls movement is relatively easier.
Coercivity and retentivity are large	Coercivity and retentivity are small.
Susceptibility and permeability values are low.	Susceptibility and permeability values are high.
Eg: tungsten steels	Eg: iron silicon alloys
Applications: Toys, compass needles, microphones speed motors,	Applications: Transformer cores, motors, relays, sensors, storage components.

APPLICATIONS MAGNETIC MATERIALS:

- ❖ Soft magnetic materials are used in transformer cores, motors, relays and sensors.
- ❖ Iron-silicon alloy magnets are used in electrical equipments.
- ❖ Silicon steel magnets are used in alternators and high frequency rotating materials.
- ❖ Soft magnetic materials are used in storage components and microwave isolators.
- ❖ Hard magnetic materials are used in production of permanent magnetism



- ❖ Carbon steel magnets are used in toys, compass needles, meters etc.
- ❖ tungsten steel magnets are used in dc meters and measuring devices.
- ❖ Neodymium magnets are used in microphones.
- ❖ Cast AlNiCo magnets are used in speed meters, and sensors in automobiles, motors etc.,
- ❖ Microwave devices like isolators and circulator phase shifters are prepared employing ferrites.
- ❖ Hard ferrites are used to make loud speakers and wiper motors.
- ❖ Ferrite rods are used to make small antennas

