

# UNIT 1

## LOAD MODELLING AND CHARACTERISTICS

## UNIT1

### LOADMODELLINGANDCHARACTERISTICS

#### DEFINITIONS

**Load** Electrical power needed in kW or kVA

**Demand** The power requirement (in kVA or kW) at the load averaged over a specified interval (15 min or 30 min). Sometimes it is given in amperes at a specified voltage level.

**Demand Intervals** The time interval specified for demand ( $D$ ), usually 15 min or 30 min. This is obtained from daily demand curves or load duration curves.

**Maximum Demand** The maximum load (or the greatest if a unit or group of units) that occurred in a period of time as specified. This can be daily, weekly, seasonal or on annual basis (for billing purpose in India it is monthly and in kVA).

**Demand Factor** The ratio of maximum demand to the total load connected to the system

**Connected Load** The sum total of the continuous rating of all the apparatus, equipment, etc., Connected to the system.

**Utilization Factor** The ratio of maximum demand to the rated capacity of the system.

**Load Factor** The ratio of average load in given interval of time to the peak during that interval.

**Annual Load Factor** The ratio of total energy supplied in an year to annual peak load multiplied by 8760.

**Diversity Factor ( $D_p$ )** The ratio of sum of the individual maximum demands of various sub-divisions of the system to the maximum demand of the entire or complete system.

**Coincident Maximum Demand ( $D_g$ )** Any demand that occurs simultaneously with any other demand and also the sum of any set of coincident demands.

**Coincidence factor ( $C_p$ )** This is usually referred to a group of consumers or loads. It is defined as the ratio of coincident maximum demand  $D_g$  to sum total of maximum demands of individual or group of loads.

Generally, it is taken as the reciprocal of the diversity factor.

**Load Diversity** The difference between the sum of peaks of two or more individual loads and the peak of combined load.

$$\text{Load diversity} = \sum D_i - D_g \quad (2.1)$$

$D_i$  = individual maximum demand

$D_g$  = coincident maximum demand

**Contribution Factor** This is a factor that is usually referred in distribution systems regarding the importance of weighted effect of a particular load.

If  $C_1, C_2 \dots C_n$  are the contribution factors of each of the  $n$  individual loads and  $D_1, D_2, D_3 \dots D_n$  are their maximum demands.

$D_g$  = coincident maximum demand is taken as

$$D_g = C_1 D_1 + C_2 D_2 + \dots C_n D_n = \sum_{i=1}^n C_i D_i \quad \dots (2.2)$$

$$\text{Hence } C_f = \text{coincidence factor is } = \frac{\sum C_i D_i}{\sum D_i} \quad \dots (2.3)$$

The contribution factor  $C_i = C_f$  when all the demands equally affect or influence the maximum demand.

**Loss Factors** This is the ratio of average power loss in the system to power loss during peak load period and referred to the variable power losses, i.e., copper losses or power loss in conductors or windings but not to no load losses in transformers, etc.

## LOADS AND LOAD CHARACTERISTICS

A broad classification of loads are

- (i) Domestic and residential loads
- (ii) Only lighting loads (such as for street lights etc.)
- (iii) Commercial loads (shops, business establishments, hospitals)
- (iv) Industrial loads
- (v) Agricultural loads and other rural loads

### 1 Domestic and Residential Loads

The important part in the distribution system is domestic and residential loads as they are highly variable and erratic. These consist of lighting loads, domestic appliances such as water heaters, washing machines, grinders and mixers, TV and electronic gadgets etc. The duration of these loads will be few minutes to few hours in a day. The power factor of these loads is less and may vary between 0.5 to 0.7. In residential flats and bigger buildings, the diversity between each residence will be less typically between 1.1 to 1.15. The load factor for domestic loads will be usually 0.5 to 0.6.

### .2 Industrial Loads

Industrial loads are of greater importance in distribution systems with demand factor 0.7 to 0.8 and load factor 0.6 to 0.7. For heavy industries demand factor may be 0.9 and load factor 0.7 to 0.8

Typical power range for various loads

Cottage and small-scale industries: 3 to 20 kW.

Medium industries (like rice mills, oil mills, workshops, etc.) : 25 to 100 kW

Large industries connected to distribution feeders (33 kV and below): 100 to 500 kW.

### 3 Water supply and Agricultural Loads

Most of the panchayats, small and medium municipalities have protected water system which use pumping stations. They normally operate in off peak time and use water pumps ranging from 10 h.p to 50 h.p or more, depending on the population and area.

### 4 Agricultural and Irrigation Loads

Most of the rural irrigation in India depends on ground water pumping or lifting water from tanks or nearby canals. In most cases design and pump selection is very poor with efficiencies of the order of 25%. Single phase motors are used (up to 10 h.p.) for ground water level 15 m in depth or less with discharge of about 20 l/sec while multi stage submersible pumps with discharge of 800 to 1000 l/m may require motors of 15 to 20 h.p.

## RELATION BETWEEN LOAD AND LOSS FACTOR:

In general, load changes occur continuously for any type of load and the load pattern on any feeder or distributor can be idealized and simplified approach for load on a feeder can be taken as shown in Fig.

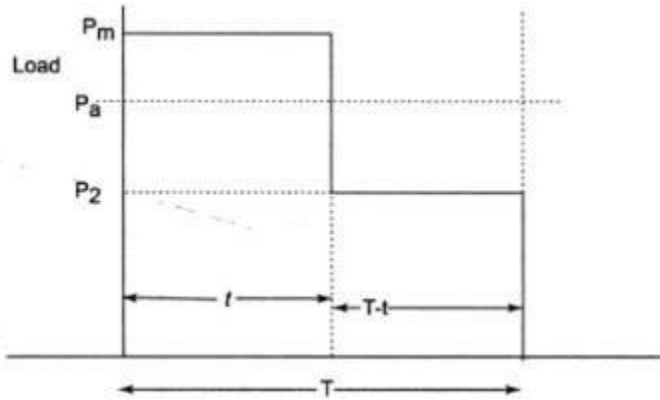

Let a peak load  $P_m$  exist for duration of ' $t$ ' and  $P_2$  be the off peak load during any interval ' $T$ ' considered. Let  $P_a$  be the average load during the period ' $T$ '.

$$P_a = \frac{P_m \times t + P_2(T - t)}{T} \quad \dots (2.4)$$

$$\text{But load factor} = \frac{P_{av}}{P_{peak}} = \frac{P_a}{P_m}$$

For the duration ' $T$ ' considered

$$\begin{aligned} \text{Load factor} &= \frac{P_m \times t + P_2(T - t)}{P_m \times T} \\ &= \frac{t}{T} + \frac{P_2}{P_m} \frac{(T - t)}{T} \end{aligned} \quad \dots (2.5)$$

$$\text{and loss factor} = \frac{(\text{Power loss (avg) in given time period})}{\text{power loss (max. loss)} \times \text{the total duration}}$$

This can be extended to the whole duration of 24 hours by considering  $P_1, P_2, \dots, P_k$  as the loads occurring over a duration of  $t_1, t_2, \dots, t_k$  with  $P_m$  as the peak load. If  $P_{LS}$  is average power loss and  $P_{lm}$  power loss corresponding to peak load  $P_m$ .

$$\text{Loss factor} = \frac{P_{LS}}{P_{lm}} = \frac{P_{LS}t + P_m(T - t)}{P_{lm} \times T} \quad \dots (2.6)$$

Since losses are proportional to  $I^2 \times P^2$

( $\because$  voltage is constant)

$$\text{Loss factor} = \frac{t}{T} + \left( \frac{P_{avg}}{P_m} \right)^2 \left( \frac{T - t}{T} \right) \quad \dots (2.7)$$

(a) This is  $= t/T$  if off peak load i.e  $P_2 \times 0$ , (same as load factor)

(b) For short time peak  $t \ll T$  loss factor  $= \left( \frac{P_{avg}}{P_m} \right) = (load\ factor)^2$  (2.8)

(c) In general for variable industrial loads loss factor, is taken as

$$= 0.3(\text{load factor}) + 0.7 (\text{load factor})^2 \quad \dots (2.9)$$

**Example 2.7** Find the annual load factor and average demand, given that peak load is 3.5 MW and energy supplied is 10 million units ( $10^7$  kWh). Peak demand was recorded during April – June.

**Solution** Average demand  $= \frac{10^7 \text{ kWh}}{8760} = 1141 \text{ kW}$

$$\text{Peak load} = 3500 \text{ kW}$$

$$\text{Annual load factor} = \frac{1141}{3500} = 0.326$$

**Example 2.8** A feeder supplies 2 MW to an area. The total losses at peak load are 100 kW and units supplied to that area during an year are 5.61 million. Calculate the loss factor.

**Solution** Load factor  $= \frac{5.61 \times 10^6}{200 \times 8760} = 0.32$  (unit supplied/ peak load  $\times$  8760)

$$\text{Loss factor} = 0.3 (\text{load factor}) + 0.7 (\text{load factor})^2$$

$$= 0.3 \times 0.32 + 0.7 \times (0.32)^2 = 0.168$$

$$\text{Average power loss} = 0.168 \times (100 \text{ kW}) = 16.8 \text{ kW}$$

The above examples illustrate how the average power loss and loss factor can be estimated from the peak load occurring and units supplied. The estimates give gross idea regarding power losses and hence the revenue lost in a distribution system. The loss factor should be as low as possible so that the energy efficiency will be high. In general, loss factor will be such that

$$(\text{load factor})^2 < (\text{loss factor}) < (\text{load factor})$$

# UNIT 2

## CLASSIFICATION OF DISTRIBUTION SYSTEMS

## UNIT 2

### Distribution System

That part of power system which distributes electric power for local use is known as **distribution system**.

In general, the distribution system is the electrical system between the sub-station fed by the distribution system and the consumers meters. It generally consists of *feeders, distributors* and the *service mains*.

- (i) **Feeders.** A feeder is a conductor which connects the sub-station (or localised generating station) to the area where power is to be distributed. Generally, no tappings are taken from the feeder so that current in it remains the same throughout. The main consideration in the design of a feeder is the current carrying capacity.

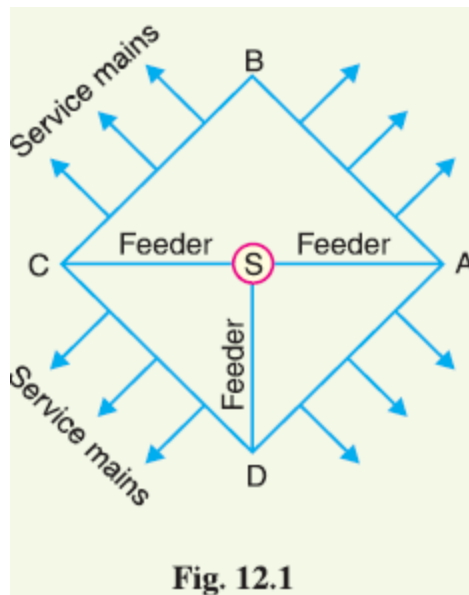

Fig. 12.1

(ii) **Distributor.** A distributor is a conductor from which tappings are taken for supply to the consumers. In Fig. 12.1, *AB, BC, CD* and *DA* are the distributors. The current through a distributor is not constant because tappings are taken at various places along its length. While designing a distributor, voltage drop along its length is the main consideration since the statutory limit of voltage variation is  $\pm 6\%$  of rated value at the consumers' terminals.

(iii) **Service mains.** A service main is generally a small cable which connects the distributor to the consumers' terminals.

### Classification of Distribution Systems

A distribution system may be classified according to;

- (i) **Nature of current.** According to nature of current, distribution system may be classified as (a) d.c. distribution system (b) a.c. distribution system.

Now-a-days, a.c. system is universally adopted for distribution of electric power as it is simpler and more economical than direct current method.

**(ii) Type of construction.** According to type of construction, distribution system may be classified as (a) overhead system (b) underground system.

The overhead system is generally employed for distribution as it is 5 to 10 times cheaper than the equivalent underground system. In general, the underground system is used at places where overhead construction is impracticable or prohibited by the local laws.

**(iii) Scheme of connection.** According to scheme of connection, the distribution system may be classified as (a) radial system (b) ring main system (c) interconnected system. Each scheme has its own advantages and disadvantages.

### A.C. Distribution

- Now-a-days electrical energy is generated, transmitted and distributed in the form of alternating current.
- Alternating current is preferred to direct current is the fact that alternating voltage can be conveniently changed by means of a transformer.
- High distribution and transmission voltages have greatly reduced the current in the conductors and the resulting line losses.
- The a.c. distribution system is the electrical system between the step-down substation fed by the distribution system and the consumers' meters.

The a.c. distribution system is classified into

- (i)** primary distribution system and
- (ii)** secondary distribution system.

### PRIMARY DISTRIBUTION SYSTEM.

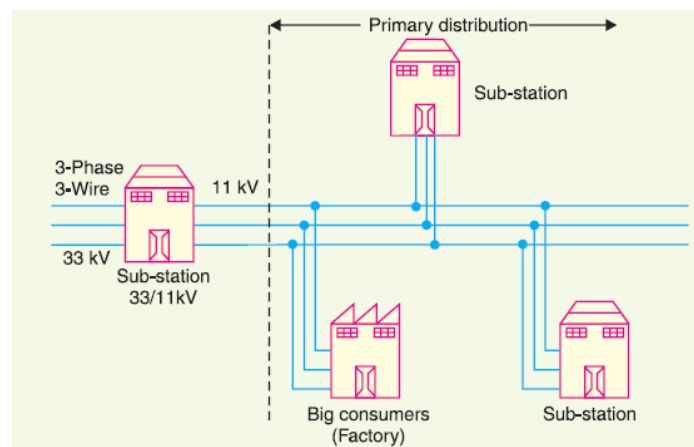

- It is that part of a.c. distribution system which operates at voltages somewhat higher than general utilisation than the average low-voltage consumer uses.
- The most commonly used primary distribution voltages are 11 kV, 6.6 kV and 3.



3 kV

- Primary distribution is carried out by 3-phase, 3-wire system.
- Fig. shows a typical primary distribution system.
- Electric power from the generating station is transmitted at a high voltage to the substation located in or near the city. At this substation, voltage is stepped down to 11 kV with the help of a step-down transformer. Power is supplied to various substations for distribution or to big consumers at this voltage. This forms the high voltage distribution or primary distribution.

### SECONDARY DISTRIBUTION SYSTEM.

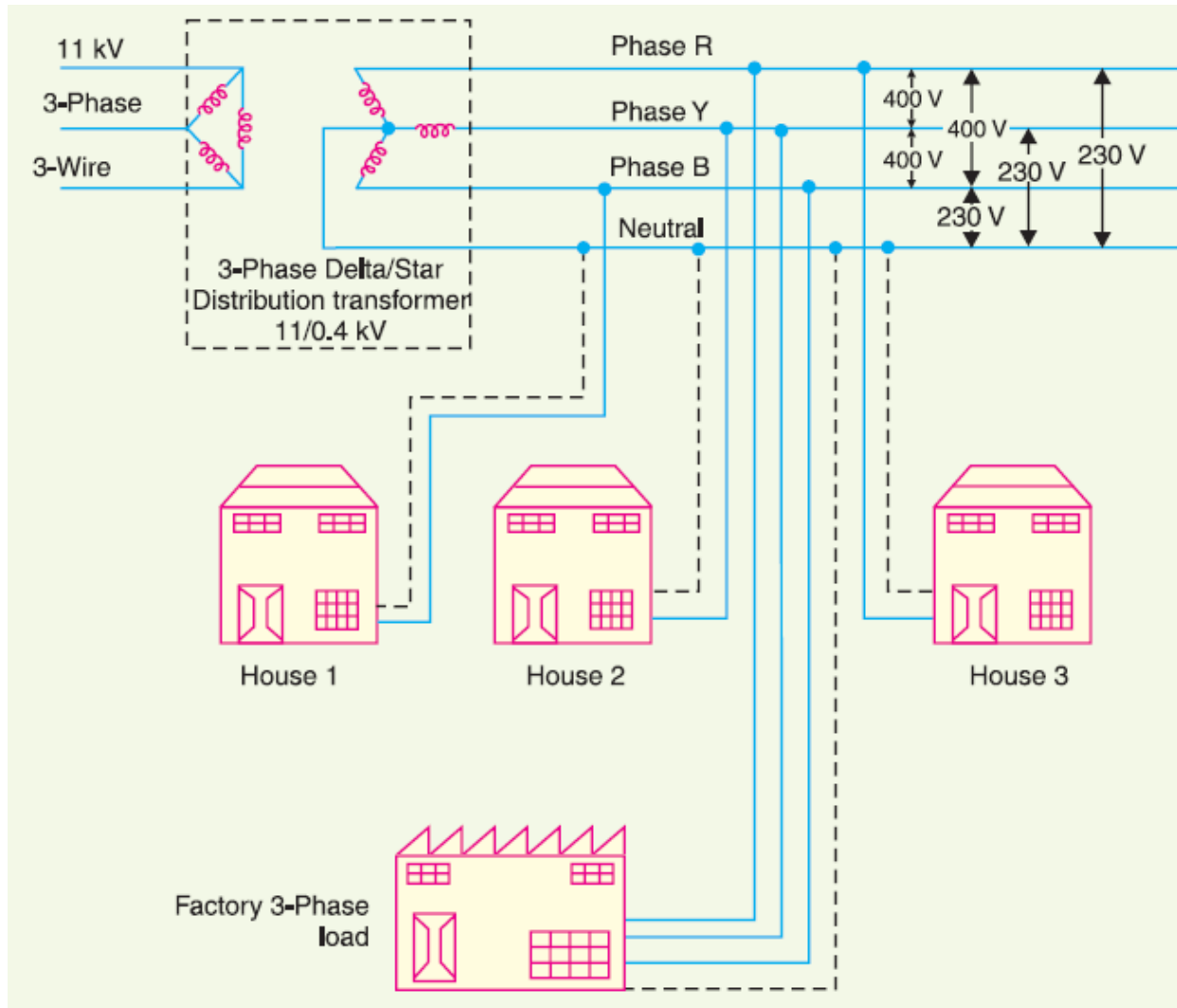

- It is that part of a c. distribution system that employs 400/230V, 3-phase, 4-wire system.
- shows a typical secondary distribution system.
- The primary distribution circuit delivers power to various substations, called distribution substations. The substations are situated near the consumers' localities and contain step-down transformers.
- At each distribution substation, the voltage is stepped down to 400V and power is delivered by 3-phase, 4-wire a.c. system.
- The voltage between any two phases is 400V and between any phase and neutral is 230V.

- The single phase domestic loads are connected between any one phase and the neutral,.
- Motor loads are connected across 3-phase lines directly.

## D.C. Distribution

- For certain applications, d.c. supply is absolutely necessary. d.c. supply is required for the operation of variable speed machinery (*i.e.*, d.c. motors storage battery).
- For this purpose, a.c. power is converted into d.c. power at the substation by using converting machinery *e.g.*, mercury arc rectifiers, rotary converters and motor-generator sets.

The d.c. supply obtained in the form of (i) 2-wire or (ii) 3-wire for distribution.

### 2- WIRED.C.SYSTEM

- As the name implies, this system of distribution consists of two wires.
- One is the outgoing or positive wire and the other is the return or negative wire.
- The loads such as lamps, motor etc. are connected in parallel between the two wires as shown in Fig.
- This system is never used for distribution purposes due to low efficiency but may be employed for distribution of d.c. power.

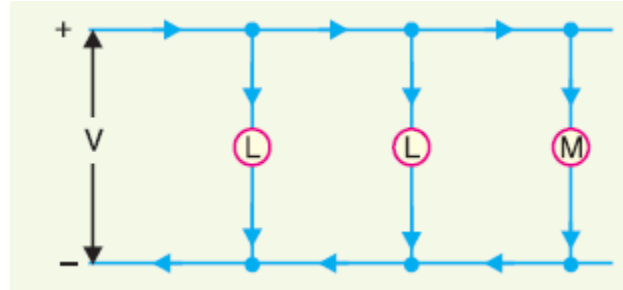

### 3- wired.c.system.

- It consists of two outers and a middle or neutral wire which is earthed at the substation.
- The voltage between the outers is twice the voltage between either outer and neutral.
- The principal advantage of this system is that it makes available two voltages at the consumer terminals,
- $V$  between any outer and the neutral and  $2V$  between the outers.

- Loads requiring high voltage (e.g., motors) are connected across the outers, whereas lamps and heating circuits requiring less voltage are connected between either outer and the neutral.

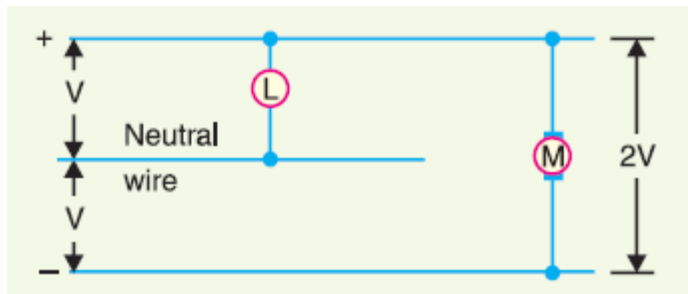

## Comparison of D.C. and A.C. distribution

The electric power can be distributed either by means of d.c. or a.c. Each system has its own merits and demerits

### 1. D.C. distribution

#### Advantages.

- (i) It requires only two conductors as compared to three for a.c. distribution.
- (ii) There is no inductance, capacitance, phase displacement and surge problems in d.c. distribution.
- (iii) Due to the absence of inductance, the voltage drop in a d.c. distribution line is less than the a.c. line for the same load and sending end voltage. For this reason, a d.c. distribution line has better voltage regulation.
- (iv) There is no skin effect in a d.c. system. Therefore, entire cross-section of the line conductor is utilized.
- (v) For the same working voltage, the potential stress on the insulation is less in case of d.c. system than that in a.c. system. Therefore, a d.c. line requires less insulation.
- (vi) A d.c. line has less coronal loss and reduced interference with communication circuits.
- (vii) The high voltage d.c. distribution is free from the dielectric losses, particularly in the case of cables.
- (viii) In d.c. distribution, there are no stability problems and synchronising difficulties.

#### Disadvantages

- (i) Electric power cannot be generated at high d.c. voltage due to commutation problems.
- (ii) The d.c. voltage cannot be stepped up for distribution of power at high voltages.
- (iii) The d.c. switches and circuit breakers have their own limitations.

## 2. A.C.distribution

### Advantages

- (i) The power can be generated at high voltages.
- (ii) The maintenance of a.c. sub-stations is easy and cheaper.
- (iii) The a.c. voltage can be stepped up or stepped down by transformers with ease and efficiency. This permits to transmit power at high voltages and distribute it at safe potentials.

### Disadvantages

- (i) An a.c. line requires more copper than a d.c. line.
- (ii) The construction of a.c. distribution line is more complicated than a d.c. distribution line.
- (iii) Due to skin effect in the a.c. system, the effective resistance of the line is increased.
- (iv) An a.c. line has capacitance. Therefore, there is a continuous loss of power due to charging current even when the line is open.

## OVERHEAD VERSUS UNDERGROUND SYSTEM

- The distribution system can be overhead or underground.
- Overhead lines are generally mounted on wooden, concrete or steel poles which are arranged to carry distribution transformers in addition to the conductors.
- The underground system uses conduits, cables and manholes under the surface of streets and sidewalks.

The choice between overhead and underground system depends upon a number of widely differing factors.

**(i) Public safety.** The underground system is more safe than overhead system because all distribution wiring is placed underground and there are little chances of any hazard.

**(ii) Initial cost.** The underground system is more expensive due to the high cost of trenching, conduits, cables, manholes and other special equipment. The initial cost of an underground system may be five to ten times than that of an overhead system.

**(iii) Flexibility.** The overhead system is much more flexible than the underground system. In the latter case, manholes, duct lines etc., are permanently placed once installed and the load expansion can only be met by laying new lines. However, on a

noverheadsystem,poles,wires,transformersetc.,canbeeasilyshiftedto  
meetthechangesinloadconditions.

**(iv) Faults.** The chances of faults in underground system are very rare as the cables are laid underground and are generally provided with better insulation.

**(v) Appearance.** The general appearance of an underground system is better as all the distribution lines are invisible. This factor is exerting considerable public pressure on electric supply companies to switch over to underground system.

**(vi) Fault location and repairs.** In general, there are little chances of faults in an underground system. However, if a fault does occur, it is difficult to locate and repair on this system. On an overhead system, the conductors are visible and easily accessible so that fault locations and repairs can be easily made.

**(vii) Current carrying capacity and voltage drop.** An overhead distribution conductor has a considerably higher current carrying capacity than an underground cable conductor of the same material and cross-section. On the other hand, underground cable conductor has much lower inductive reactance than that of an overhead conductor because of closer spacing of conductors.

**(viii) Useful life.** The useful life of underground system is much longer than that of an overhead system. An overhead system may have a useful life of 25 years, whereas an underground system may have a useful life of more than 50 years.

**(ix) Maintenance cost.** The maintenance cost of underground system is very low as compared with that of overhead system because of less chances of faults and service interruptions from wind, ice, lightning as well as from traffic hazards.

**(x) Interference with communication circuits.** An overhead system causes electromagnetic interference with the telephone lines. The power line currents are superimposed on speech currents, resulting in the potential of the communication channel being raised to an undesirable level. However, there is no such interference with the underground system.

It is clear from the above comparison that each system has its own advantages and disadvantages.

## DESIGN CONSIDERATIONS IN DISTRIBUTION SYSTEM

Good voltage regulation of a distribution network is probably the most important factor responsible for delivering good service to the consumers. For this purpose, design of feeders and distributors requires careful consideration.

**(i) Feeders.** A feeder is designed from the point of view of its current carrying capacity while the voltage drop consideration is relatively unimportant. It is because voltage drop in a feeder can be compensated by means of voltage regulating equipment at the substation.

**(ii) Distributors.** A distributor is designed from the point of view of the voltage drop in it. It is because a distributor supplies power to the consumers and there is a statutory limit of voltage variations at the consumer's terminals ( $\pm 6\%$  of rated value). The size and length of the distributor should be such that voltage at the consumer's terminals is within the permissible limits.

## REQUIREMENTS OF A DISTRIBUTION SYSTEM

requirements of a good distribution system are: proper voltage, availability of power on demand and reliability.

**(i) Proper voltage.** One important requirement of a distribution system is that voltage variations at consumer's terminals should be as low as possible. The changes in voltage are generally caused due to the variation of load on the system. Low voltage causes loss of revenue, inefficient lighting and possible burning out of motors. High voltage causes lamps to burn out permanently and may cause failure of other appliances. Therefore, a good distribution system should ensure that the voltage variations at consumers terminals are within permissible limits. The statutory limit of voltage variations is  $\pm 6\%$  of the rated value at the consumer's terminals. Thus, if the declared voltage is 230 V, then the highest voltage of the consumers should not exceed 244 V while the lowest voltage of the consumers should not be less than 216 V.

**(ii) Availability of power on demand.** Power must be available to the consumers in any amount that they may require from time to time. For example, motors may be started or shutdown, lights may be turned on or off, without advance warning to the electric supply company. As electrical energy cannot be stored, therefore, the distribution system must be capable of supplying load demands of the consumers. This necessitates that operating staff must continuously study load patterns to predict in advance those major load changes that follow the known schedules.

**(iii) Reliability.** Modern industry is almost dependent on electric power for its operation. Homes and office buildings are lighted, heated, cooled and ventilated by el



ectric power. This calls for reliable service. Unfortunately, electric power, like everything else that is man-made, can never be absolutely reliable. However, the

reliability can be improved to a considerable extent by (a) interconnected system (b) reliable automatic control system (c) providing additional reserve facilities.

## CONNECTION SCHEMES OF DISTRIBUTION SYSTEM

### (i) Radial System.

- In this system, separate feeders radiate from a single substation and feed the distributors at one end only.
- Fig.(i) shows a single line diagram of a radial system for d.c. distribution where a feeder OC supplies a distributor AB at point A.
- distributor is fed at one end only i.e., point A in this case.
- Fig.(ii) shows a single line diagram of a radial system for a.c. distribution.

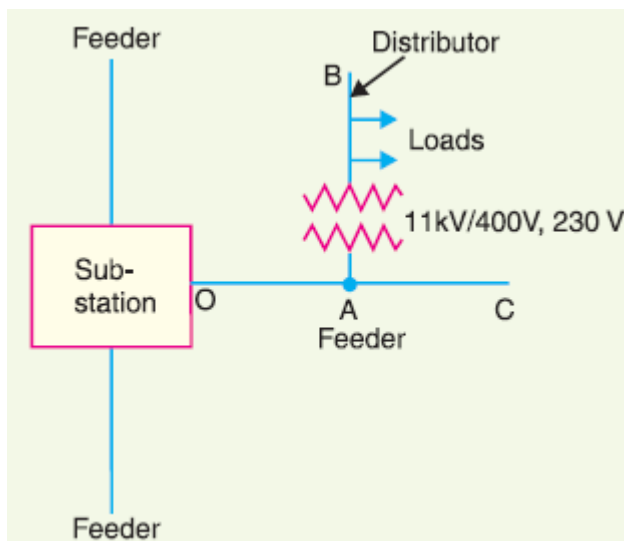
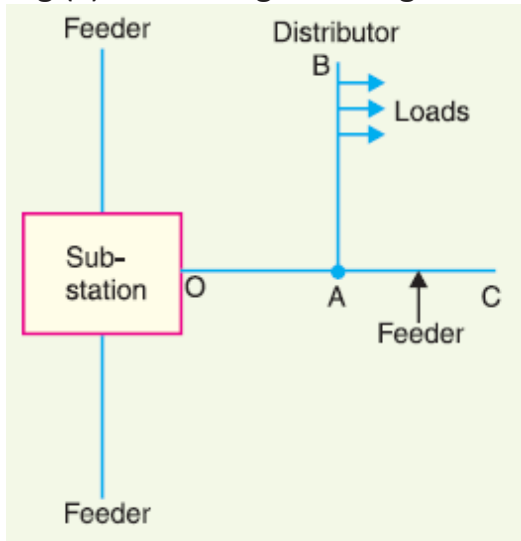

- This is the simplest distribution circuit and has the lowest initial cost.

**DRAWBACKS:**

- (a) The end of the distributor nearest to the feeding point will be heavily loaded. (b) any fault on the feeder or distributor cuts off supply to the consumers who are on the side of the fault.
- (c) The consumers at the distant end of the distributor would be subjected to serious voltage fluctuations when the load on the distributor changes.

Due to these limitations, this system is used for short distances only.

**(ii) Ring main system.**

- In this system, the primaries of distribution transformers form a loop.
- The loop circuit starts from the substation bus-bars, makes a loop through the area to be served, and returns to the substation.
- Fig. 12.9 shows the single line diagram of ring main system for a.c. distribution where substations supply to the closed feeder LMNOPQRS.
- The distributors are tapped from different points M, O and Q of the feeder through distribution transformers.

**ADVANTAGES:**

- (a) There are less voltage fluctuations at consumer's terminals.
- (b) The system is very reliable as each distributor is fed via two feeders. In the event of a fault on any section of the feeder, the continuity of supply is maintained.

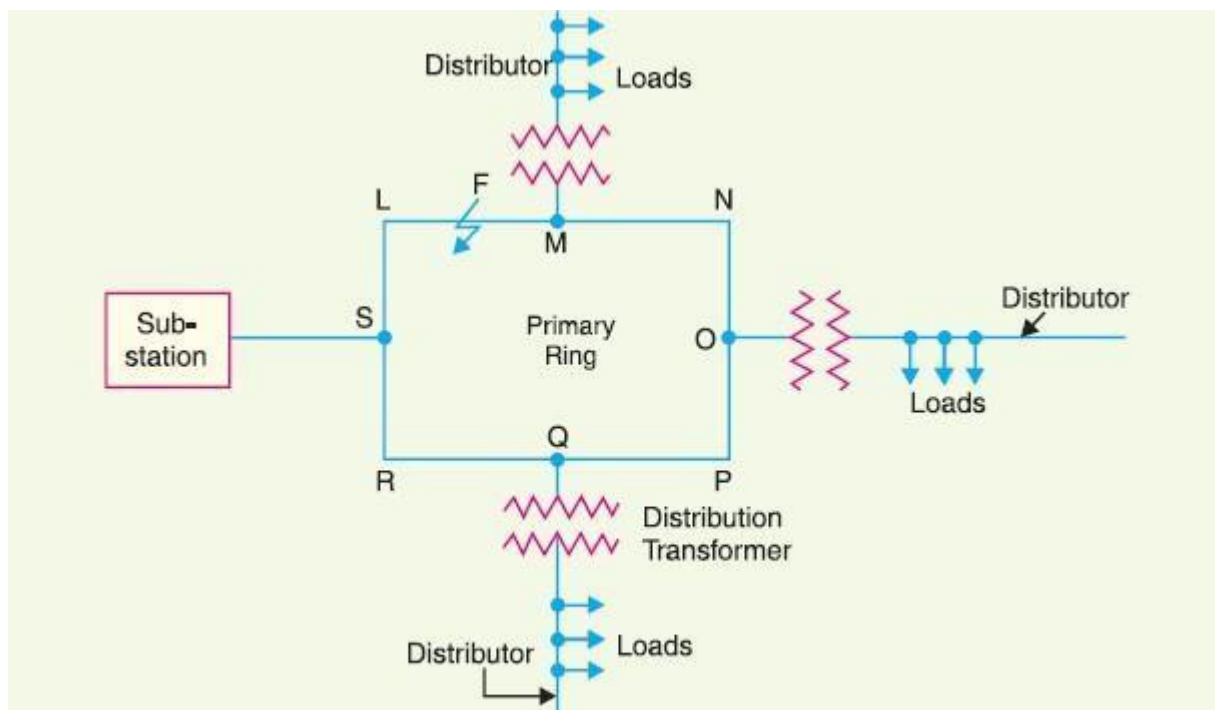

**Fig. 12.9**

### (iii) Interconnected system.

- When the feeder ring is energised by two or more than two generating stations or substations, it is called an interconnected system.
- Fig. 12.10 shows the single line diagram of an interconnected system where the closed feeder ring ABCD is supplied by two substations S<sub>1</sub> and S<sub>2</sub> at points D and C respectively.

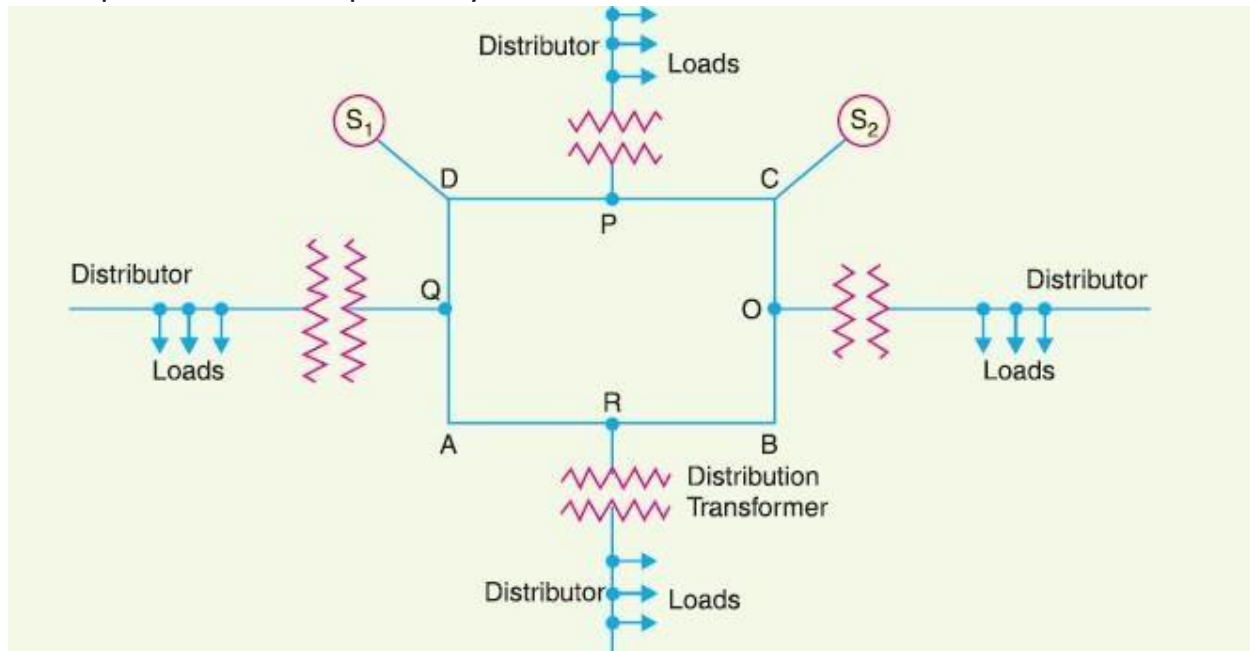

- Distributors are connected to points O, P, Q and R of the feeder ring through distribution transformers.

#### ADVANTAGES:

- (a) It increases the service reliability.
- (b) Any area fed from one generating station during peak load hours can be fed from the other generating station. This reduces reserve power capacity and increases efficiency of the system.

### A.C. DISTRIBUTION VOLTAGE CALCULATIONS

In a.c. distribution calculations, power factors of various load currents have to be considered since currents in different sections of the distributor will be the vector sum of load currents and not the arithmetic sum. The power factors of load currents may be given (i) w.r.t. receiving or sending end voltage or (ii) w.r.t. to load voltage itself. Each case shall be discussed separately.

#### (i) Power factors referred to receiving end

**voltage.** Consider a.c. distributor AB with concentrated loads of  $I_1$  and  $I_2$  tapped off at points C and B as shown in Fig. Taking the receiving end voltage  $V_B$  as the reference vector, let lagging power factors at C and B be  $\cos \phi_1$  and  $\cos \phi_2$  w.r.t.  $V_B$ .

Let  $R_1, X_1$  and  $R_2, X_2$  be the resistance and reactance of sections  $AC$  and  $CB$  of the distributor.

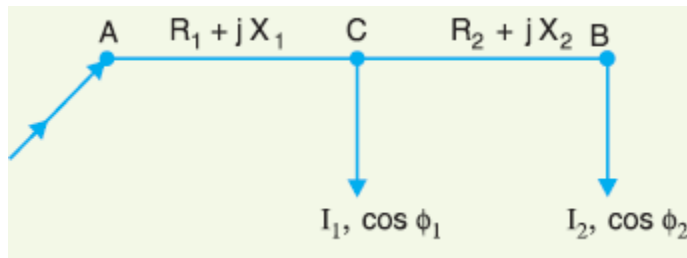

Impedance of section  $AC$ ,  $\vec{Z}_{AC} = R_1 + jX_1$

Impedance of section  $CB$ ,  $\vec{Z}_{CB} = R_2 + jX_2$

Load current at point  $C$ ,  $\vec{I}_1 = I_1 (\cos \phi_1 - j \sin \phi_1)$

Load current at point  $B$ ,  $\vec{I}_2 = I_2 (\cos \phi_2 - j \sin \phi_2)$

Current in section  $CB$ ,  $\vec{I}_{CB} = \vec{I}_2 = I_2 (\cos \phi_2 - j \sin \phi_2)$

Current in section  $AC$ ,  $\vec{I}_{AC} = \vec{I}_1 + \vec{I}_2$   
 $= I_1 (\cos \phi_1 - j \sin \phi_1) + I_2 (\cos \phi_2 - j \sin \phi_2)$

Voltage drop in section  $CB$ ,  $\vec{V}_{CB} = \vec{I}_{CB} \vec{Z}_{CB} = I_2 (\cos \phi_2 - j \sin \phi_2) (R_2 + jX_2)$

Voltage drop in section  $AC$ ,  $\vec{V}_{AC} = \vec{I}_{AC} \vec{Z}_{AC} = (\vec{I}_1 + \vec{I}_2) Z_{AC}$   
 $= [I_1 (\cos \phi_1 - j \sin \phi_1) + I_2 (\cos \phi_2 - j \sin \phi_2)] [R_1 + jX_1]$

Sending end voltage,  $\vec{V}_A = \vec{V}_B + \vec{V}_{CB} + \vec{V}_{AC}$

Sending end current,  $\vec{I}_A = \vec{I}_1 + \vec{I}_2$

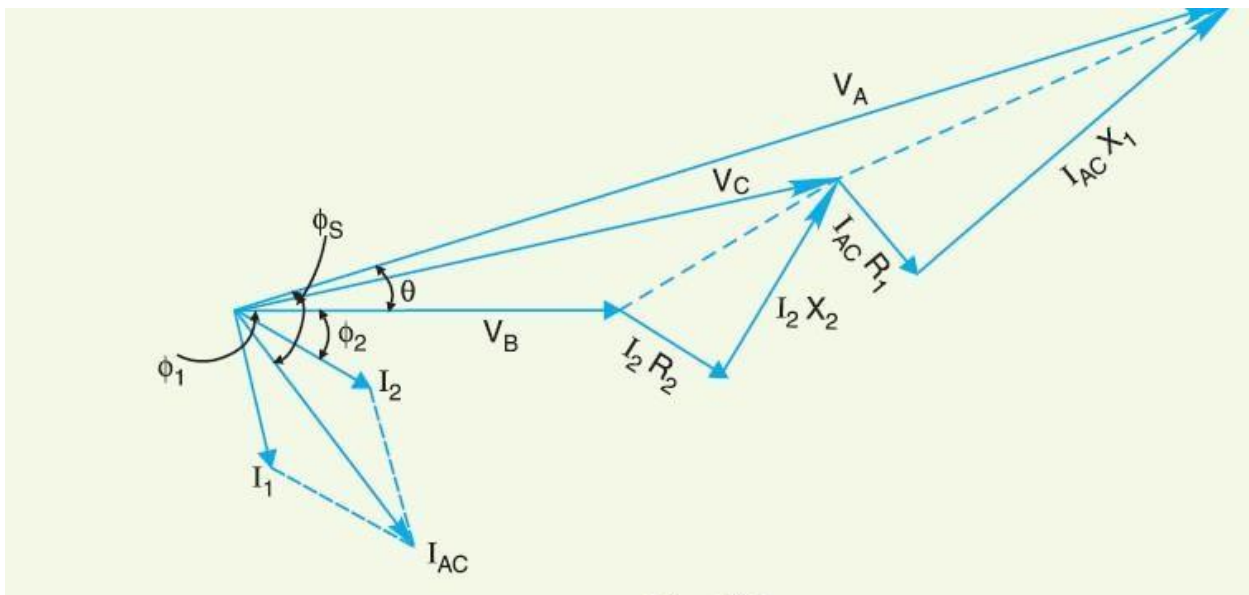

FIG. 14.4

(ii) **Power factors referred to respective load voltages.** Suppose the power factors of loads in the previous Fig. 14.1 are referred to their respective load voltages. Then  $\phi_1$  is the phase angle between  $V_C$  and  $I_1$  and  $\phi_2$  is the phase angle between  $V_B$  and  $I_2$ . The vector diagram under these conditions is shown in Fig. 14.3.

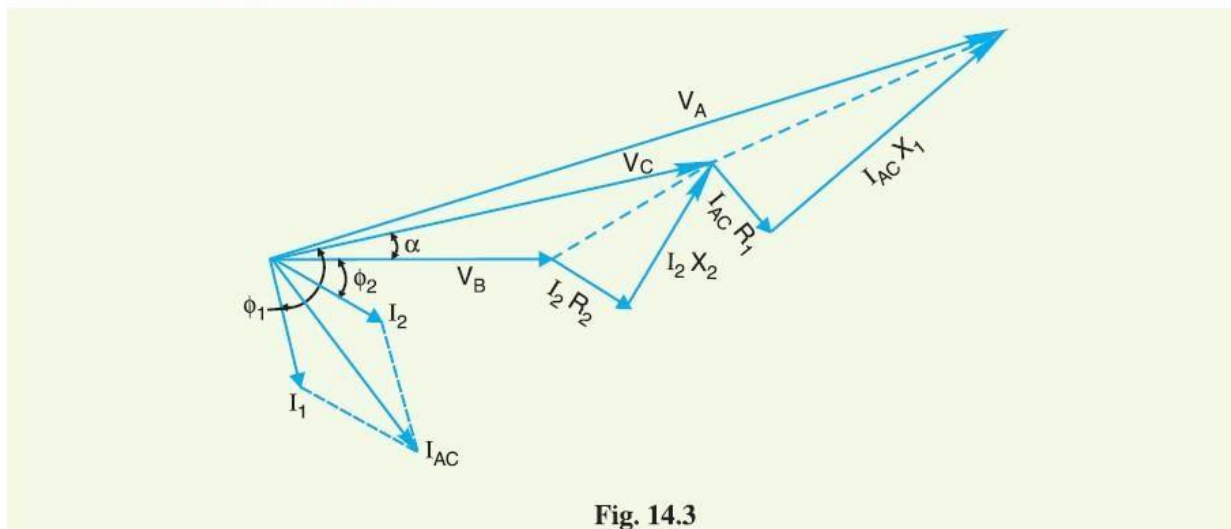

Fig. 14.3

$$\text{Voltage drop in section } CB = \vec{I}_2 \vec{Z}_{CB} = I_2 (\cos \phi_2 - j \sin \phi_2) (R_2 + j X_2)$$

$$\text{Voltage at point } C = \vec{V}_B + \text{Drop in section } CB = V_C \angle \alpha \text{ (say)}$$

$$\text{Now } \vec{I}_1 = I_1 \angle -\phi_1 \text{ w.r.t. voltage } V_C$$

$$\therefore \vec{I}_1 = I_1 \angle -(\phi_1 - \alpha) \text{ w.r.t. voltage } V_B$$

$$\text{i.e. } \vec{I}_1 = I_1 [\cos (\phi_1 - \alpha) - j \sin (\phi_1 - \alpha)]$$

$$\text{Now } \vec{I}_{AC} = \vec{I}_1 + \vec{I}_2$$

$$= I_1 [\cos (\phi_1 - \alpha) - j \sin (\phi_1 - \alpha)] + I_2 (\cos \phi_2 - j \sin \phi_2)$$

$$\text{Voltage drop in section } AC = \vec{I}_{AC} \vec{Z}_{AC}$$

$$\text{Voltage at point } A = V_B + \text{Drop in } CB + \text{Drop in } AC$$

**Example 14.1.** A single phase a.c. distributor AB 300 metres long is fed from end A and is loaded as under :

(i) 100 A at 0.707 p.f. lagging 200 m from point A

(ii) 200 A at 0.8 p.f. lagging 300 m from point A

The load resistance and reactance of the distributor is  $0.2 \Omega$  and  $0.1 \Omega$  per kilometre. Calculate the total voltage drop in the distributor. The load power factors refer to the voltage at the far end.

**Solution.** Fig. 14.4 shows the single line diagram of the distributor.

$$\text{Impedance of distributor/km} = (0.2 + j 0.1) \Omega$$

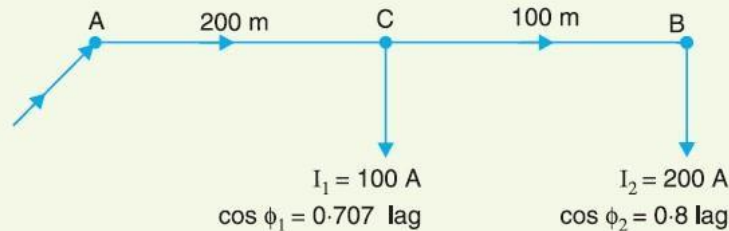

**Fig. 14.4**

$$\text{Impedance of section } AC, \quad \overline{Z}_{AC} = (0.2 + j 0.1) \times 200/1000 = (0.04 + j 0.02) \Omega$$

$$\text{Impedance of section } CB, \quad \overline{Z}_{CB} = (0.2 + j 0.1) \times 100/1000 = (0.02 + j 0.01) \Omega$$

Taking voltage at the far end B as the reference vector, we have,

$$\begin{aligned} \text{Load current at point B,} \quad \overline{I}_2 &= I_2 (\cos \phi_2 - j \sin \phi_2) = 200 (0.8 - j 0.6) \\ &= (160 - j 120) \text{ A} \end{aligned}$$

$$\begin{aligned} \text{Load current at point C,} \quad \overline{I}_1 &= I_1 (\cos \phi_1 - j \sin \phi_1) = 100 (0.707 - j 0.707) \\ &= (70.7 - j 70.7) \text{ A} \end{aligned}$$

$$\text{Current in section } CB, \quad \overline{I}_{CB} = \overline{I}_2 = (160 - j 120) \text{ A}$$

$$\begin{aligned} \text{Current in section } AC, \quad \overline{I}_{AC} &= \overline{I}_1 + \overline{I}_2 = (70.7 - j 70.7) + (160 - j 120) \\ &= (230.7 - j 190.7) \text{ A} \end{aligned}$$

$$\begin{aligned} \text{Voltage drop in section } CB, \quad \overline{V}_{CB} &= \overline{I}_{CB} \overline{Z}_{CB} = (160 - j 120) (0.02 + j 0.01) \\ &= (4.4 - j 0.8) \text{ volts} \end{aligned}$$

$$\begin{aligned} \text{Voltage drop in section } AC, \quad \overline{V}_{AC} &= \overline{I}_{AC} \overline{Z}_{AC} = (230.7 - j 190.7) (0.04 + j 0.02) \\ &= (13.04 - j 3.01) \text{ volts} \end{aligned}$$

$$\text{Voltage drop in the distributor} = \overline{V}_{AC} + \overline{V}_{CB} = (13.04 - j 3.01) + (4.4 - j 0.8)$$

$$\text{Magnitude of drop} = \sqrt{(17.44)^2 + (3.81)^2} = \mathbf{17.85 \text{ V}}$$

**Example 14.2.** A single phase distributor 2 kilometres long supplies a load of 120 A at 0.8 p.f. lagging at its far end and a load of 80 A at 0.9 p.f. lagging at its mid-point. Both power factors are referred to the voltage at the far end. The resistance and reactance per km (go and return) are 0.05  $\Omega$  and 0.1  $\Omega$  respectively. If the voltage at the far end is maintained at 230 V, calculate :

- (i) voltage at the sending end
- (ii) phase angle between voltages at the two ends.

**Solution.** Fig. 14.5 shows the distributor AB with C as the mid-point

$$\text{Impedance of distributor/km} = (0.05 + j 0.1) \Omega$$

$$\text{Impedance of section AC, } \vec{Z}_{AC} = (0.05 + j 0.1) \times 1000/1000 = (0.05 + j 0.1) \Omega$$

$$\text{Impedance of section CB, } \vec{Z}_{CB} = (0.05 + j 0.1) \times 1000/1000 = (0.05 + j 0.1) \Omega$$

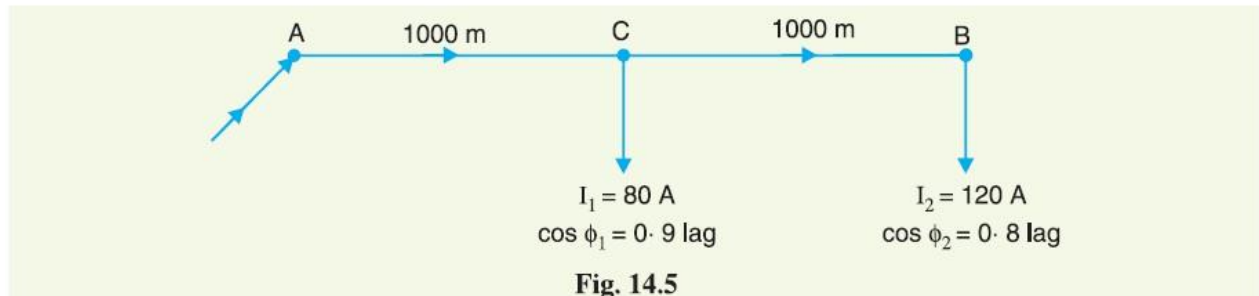

Let the voltage  $V_B$  at point B be taken as the reference vector.

$$\text{Then, } \vec{V}_B = 230 + j 0$$

$$(i) \text{ Load current at point B, } \vec{I}_2 = 120 (0.8 - j 0.6) = 96 - j 72$$

$$\text{Load current at point C, } \vec{I}_1 = 80 (0.9 - j 0.436) = 72 - j 34.88$$

$$\text{Current in section CB, } \vec{I}_{CB} = \vec{I}_2 = 96 - j 72$$

$$\begin{aligned} \text{Current in section AC, } \vec{I}_{AC} &= \vec{I}_1 + \vec{I}_2 = (72 - j 34.88) + (96 - j 72) \\ &= 168 - j 106.88 \end{aligned}$$

$$\begin{aligned} \text{Drop in section CB, } \vec{V}_{CB} &= \vec{I}_{CB} \vec{Z}_{CB} = (96 - j 72) (0.05 + j 0.1) \\ &= 12 + j 6 \end{aligned}$$

$$\begin{aligned} \text{Drop in section AC, } \vec{V}_{AC} &= \vec{I}_{AC} \vec{Z}_{AC} = (168 - j 106.88) (0.05 + j 0.1) \\ &= 19.08 + j 11.45 \end{aligned}$$



$$\begin{aligned}\therefore \text{ Sending end voltage, } \quad \vec{V}_A &= \vec{V}_B + \vec{V}_{CB} + \vec{V}_{AC} \\ &= (230 + j 0) + (12 + j 6) + (19.08 + j 11.45) \\ &= 261.08 + j 17.45\end{aligned}$$

$$\text{Its magnitude is} \quad = \sqrt{(261.08)^2 + (17.45)^2} = \mathbf{261.67 \text{ V}}$$

(ii) The phase difference  $\theta$  between  $V_A$  and  $V_B$  is given by :

$$\tan \theta = \frac{17.45}{261.08} = 0.0668$$

$$\therefore \quad \theta = \tan^{-1} 0.0668 = \mathbf{3.82^\circ}$$

UNIT 3

SUBSTATIONS

## UNIT 3

### THE RATING OF A DISTRIBUTION SUBSTATION

#### Assumptions

- (i) at constant load density for short-term distribution planning and
- (ii) at increasing load density for long-term planning.

analyzed a square-shaped service area representing a part of, or the entire service area of, a distribution substation. It is assumed that the square area is served by four primary feeders from a central feed point, as shown in Figure 4.16. Each feeder and its laterals are of three-phase. Dots represent balanced three-phase loads lumped at that location and fed by distribution transformers.

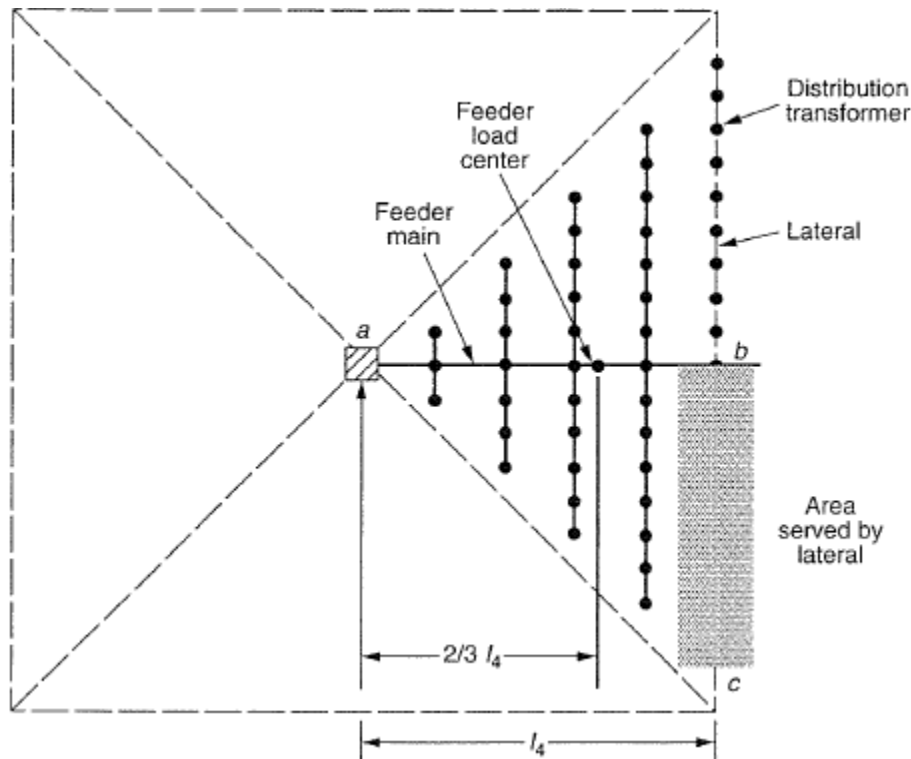

the percent voltage drop from the feed point  $a$  to the end of the last lateral at  $c$  is

$$\%VD_{ac} = \%VD_{ab} + \%VD_{bc}$$

Reps [5] simplified this voltage drop calculation by introducing a constant  $K$  which can be defined as *percent voltage drop per kilovoltampere-mile*. Figure 4.17 gives the  $K$  constant for various voltages and copper conductor sizes. Figure 4.17 is developed for three-phase overhead lines with an equivalent spacing of 37 inches between phase conductors. The following analysis is based on the work done by Denton and Reps [4] and Reps [5].

In Figure 4.16, each feeder serves a total load of

$$S_4 = A_4 \times D \text{ kVA} \quad (4.1)$$

where  $S_4$  is the kilovoltampere load served by one of four feeders emanating from a feed point,  $A_4$  is the area served by one of the four feeders emanating from a feed point ( $\text{mi}^2$ ), and  $D$  is the load density ( $\text{kVA}/\text{mi}^2$ ).

Equation 4.1 can be rewritten as

$$S_4 = l_4^2 \times D \text{ kVA} \quad (4.2)$$

since

$$A_4 = l_4^2 \quad (4.3)$$

where  $l_4$  is the linear dimension of the primary-feeder service area in miles. Assuming uniformly distributed load, that is, equally loaded and spaced distribution transformers, the voltage drop in the primary-feeder main is

$$\%VD_{4,\text{main}} = \frac{2}{3} \times l_4 \times K \times S_4 \quad (4.4)$$

or substituting Equation 4.2 into Equation 4.4,

$$\%VD_{4,\text{main}} = 0.667 \times K \times D \times l_4^3 \quad (4.5)$$

In Equations 4.4 and 4.5, it is assumed that the total or lumped sum load is located at a point on the main feeder at a distance of  $2/3 \times l_4$  from the feed point  $a$ .

Reps [5] extends the discussion to a hexagonally shaped service area supplied by six feeders from the feed point which is located at the center, as shown in Figure 4.18. Assume that each feeder service area is equal to one-sixth of the hexagonally shaped total area, or

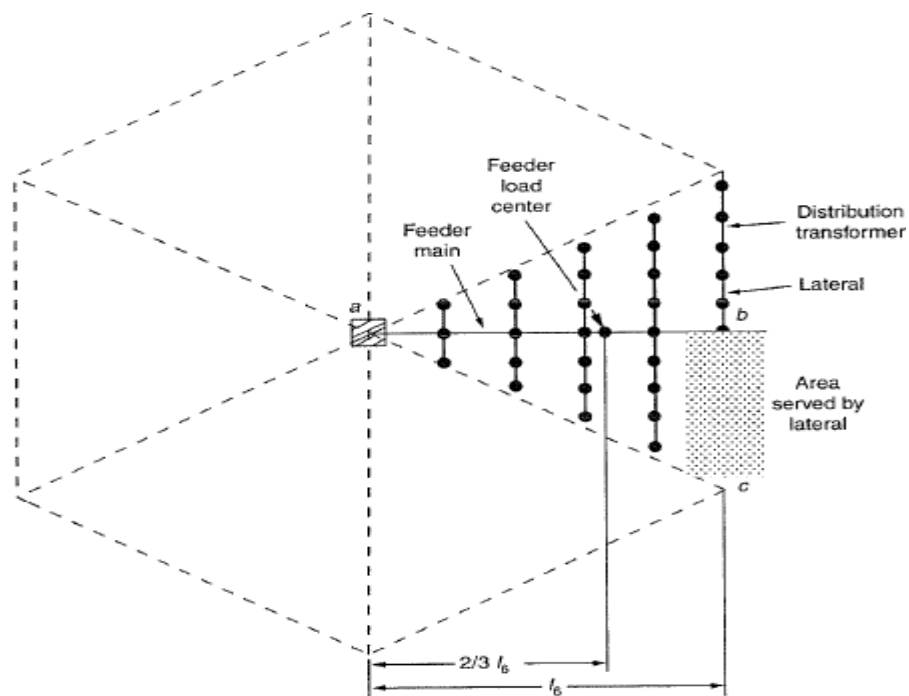

$$A_6 = \frac{l_6}{\sqrt{3}} \times l_6$$

$$= 0.578 \times l_6^2 \quad (4.6)$$

where  $A_6$  is the area served by one of the six feeders emanating from a feed point ( $\text{mi}^2$ ) and  $l_6$  is the linear dimension of a primary-feeder service area (mi).

Here, each feeder serves a total load of

$$S_6 = A_6 \times D \text{ kVA} \quad (4.7)$$

or substituting Equation 4.6 into Equation 4.7,

$$S_6 = 0.578 \times D \times l_6^2 \quad (4.8)$$

As before, it is assumed that the total or lump sum is located at a point on the main feeder at a distance of  $\frac{2}{3} \times l_6$  from the feed point. Hence, the percent voltage drop in the main feeder is

$$\%VD_{6,\text{main}} = \frac{2}{3} \times l_6 \times K \times S_6 \quad (4.9)$$

or substituting Equation 4.8 into Equation 4.9,

$$\%VD_{6,\text{main}} = 0.385 \times K \times D \times l_6^3 \quad (4.10)$$

## GENERAL CASE: SUBSTATION SERVICE AREA WITH $n$ PRIMARY FEEDERS

Denton and Reps [4] and Reps [5] extended the discussion to the general case in which the distribution substation service area is served by  $n$  primary feeders emanating from the point, as shown in Figure 4.19. Assume that the load in the service area is uniformly distributed and each feeder serves an area of triangular shape. The differential load served by the feeder in a differential area of  $dA$  is

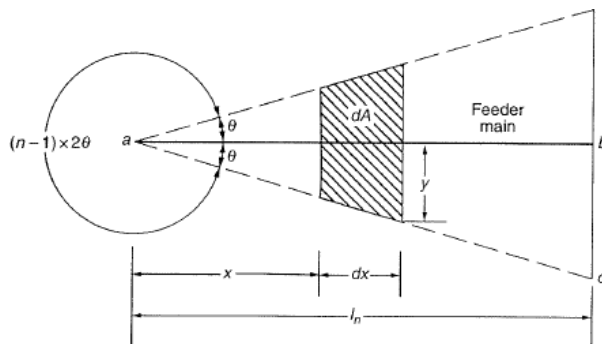

FIGURE 4.19 Distribution substation service area served by  $n$  primary feeders.

$$dS = D dA \text{ kVA} \quad (4.11)$$

where  $dS$  is the differential load served by the feeder in the differential area of  $dA$ (kVA),  $D$  is the load density (kVA/mil), and,  $dA$  is the differential service area of the feeder ( $\text{mi}^2$ ).

In Figure 4.19, the following relationship exists:

$$\tan \theta = \frac{y}{x + dx} \quad (4.12)$$

or

$$\begin{aligned} y &= (x + dx) \tan \theta \\ &\cong x \times \tan \theta. \end{aligned} \quad (4.13)$$

The total service area of the feeder can be calculated as

$$\begin{aligned} A_n &= \int_{x=0}^{l_n} dA \\ &= l_n^2 \times \tan \theta. \end{aligned} \quad (4.14)$$

The total kilovoltampere load served by one of the  $n$  feeders can be calculated as

$$\begin{aligned} S_n &= \int_{x=0}^{l_n} dS \\ &= D \times l_n^2 \times \tan \theta. \end{aligned} \quad (4.15)$$

This total load is located, as a lump-sum load, at a point on the main feeder at a distance of  $2/3 \times l_n$  from the feed point  $a$ . Hence, the summation of the percent voltage contributions of all such areas is

$$\%VD_n = \frac{2}{3} \times l_n \times K \times S_n \quad (4.16)$$

or, substituting Equation 4.15 into Equation 4.16,

$$\%VD_n = \frac{2}{3} \times K \times D \times l_n^3 \times \tan \theta \quad (4.17)$$

or, since

$$n(2\theta) = 360 \quad (4.18)$$

Equation 4.17 can also be expressed as

$$\%VD_n = \frac{2}{3} \times K \times D \times l_n^3 \times \tan \frac{360^\circ}{2n}. \quad (4.19)$$

Equations 4.18 and 4.19 are only applicable when  $n \geq 3$ . Table 4.2 gives the results of the application of Equation 4.17 to square and hexagonal areas.

**TABLE 4.2**  
**Application Results of Equation 4.17**

$n$	$\theta$	$\tan \theta$	$\%VD_n$
4	45°	1.0	$\frac{2}{3} \times K \times D \times l_4^3$
6	30°	$\frac{1}{\sqrt{3}}$	$\frac{2}{3} \times K \times D \times l_6^3$

For  $n = 1$ , the percent voltage drop in the feeder main is

$$\%VD_1 = \frac{1}{2} \times K \times D \times l_1^3 \quad (4.20)$$

and for  $n = 2$  it is

$$\%VD_2 = \frac{1}{2} \times K \times D \times l_2^3 \quad (4.21)$$

To compute the percent voltage drop in uniformly loaded lateral, lump and locate its total load at a point halfway along its length, and multiply the kilovoltampere-mile product for that line length and loading by the appropriate  $K$  constant [5].

## BusSchemes

The substation design or scheme selected determines the electrical and physical arrangement of the switching equipment. Different bus schemes can be selected as emphasis is shifted between the factors of safety, reliability, economy, and simplicity dictated by the function and importance of the substation.

### The substation bus schemes used most often are:

1. Single bus
2. Main and transfer bus
3. Double bus, single breaker
4. Double bus, double breaker
5. Ring bus
6. Breaker and a half

Some of these schemes may be modified by the addition of bus-tie breakers, bus sectionalizing devices, breaker bypass facilities, and extra transfer buses.

### (i) single bus scheme;

Single busbar scheme name itself indicates that it consists of only one busbar

Each scheme has some advantages and disadvantages

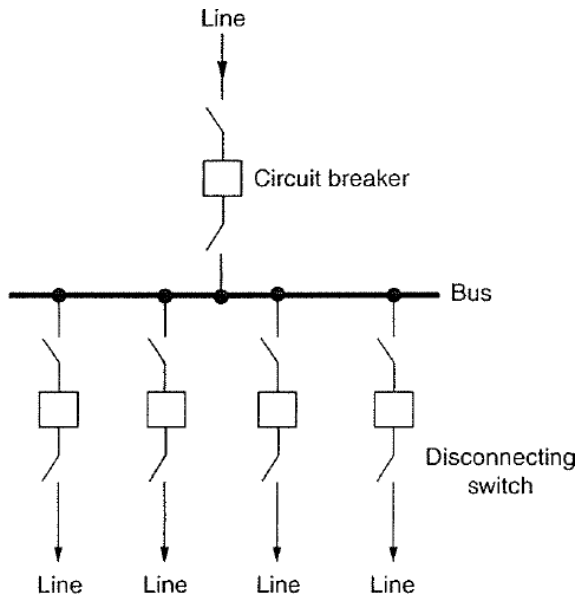

A typical single-bus scheme.

#### Switching Scheme

#### Advantages

#### Disadvantages

. Single bus

1. Lowest cost.

1. Failure of bus or any circuit breaker results in shutdown of entire substation.
2. Difficult to do any maintenance.
3. Bus cannot be extended without completely de-energizing the substation.
4. Can be used only where loads can be interrupted or have other supply arrangements.

### (ii) double bus-double breaker (or double main) scheme

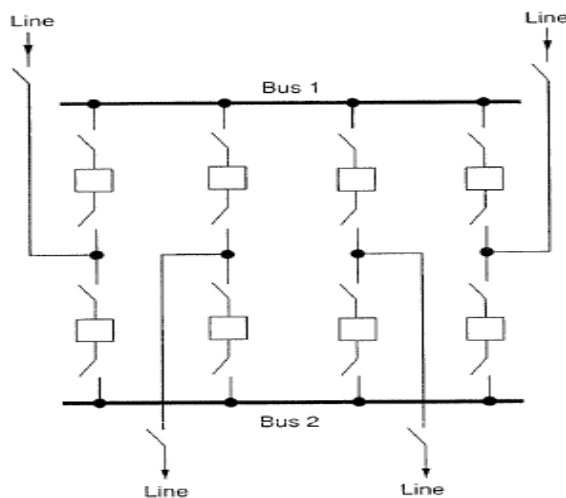

A typical double bus-double breaker scheme.



**Switching Scheme****Advantages****Disadvantages**

Double bus-double breaker

1. Each circuit has two dedicated breakers.
2. Has flexibility in permitting feeder circuits to be connected to either bus.
3. Any breaker can be taken out of service for maintenance.
4. High reliability.

1. Most expensive.
2. Would lose half the circuits for breaker failure if circuits are not connected to both buses.

(iii) main-and-transfer bus scheme;

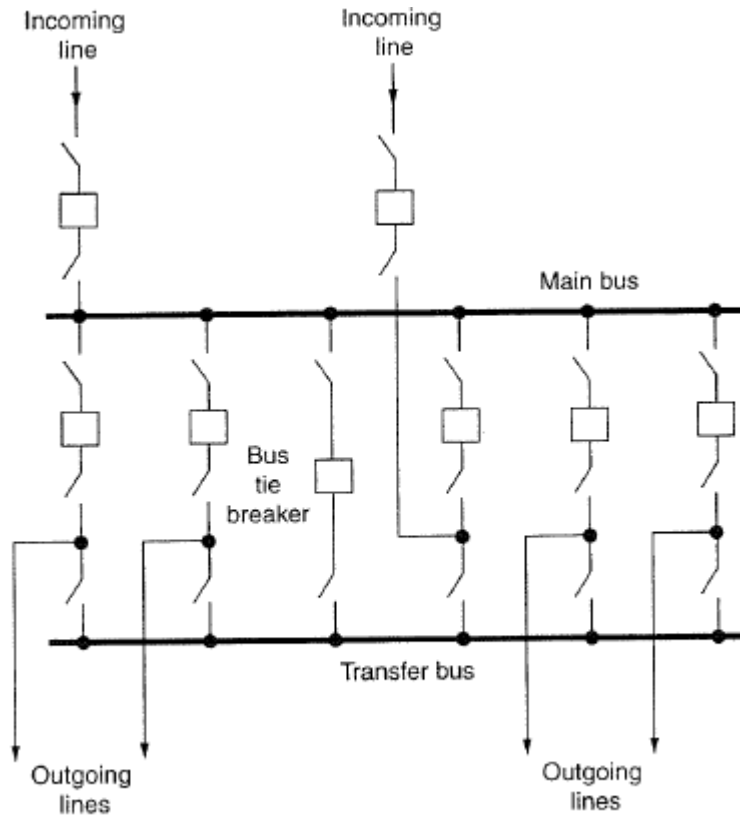

A typical main-and-transfer bus scheme.

**Switching Scheme****Advantages****Disadvantages**

Main-and-transfer

1. Low initial and ultimate cost.
2. Any breaker can be taken out of service for maintenance.
3. Potential devices may be used on the main bus for relaying.

1. Requires one extra breaker for the bus tie.
2. Switching is somewhat complicated when maintaining a breaker.
3. Failure of bus or any circuit breaker results in shutdown of entire substation.

(iv) double bus- single breaker scheme;

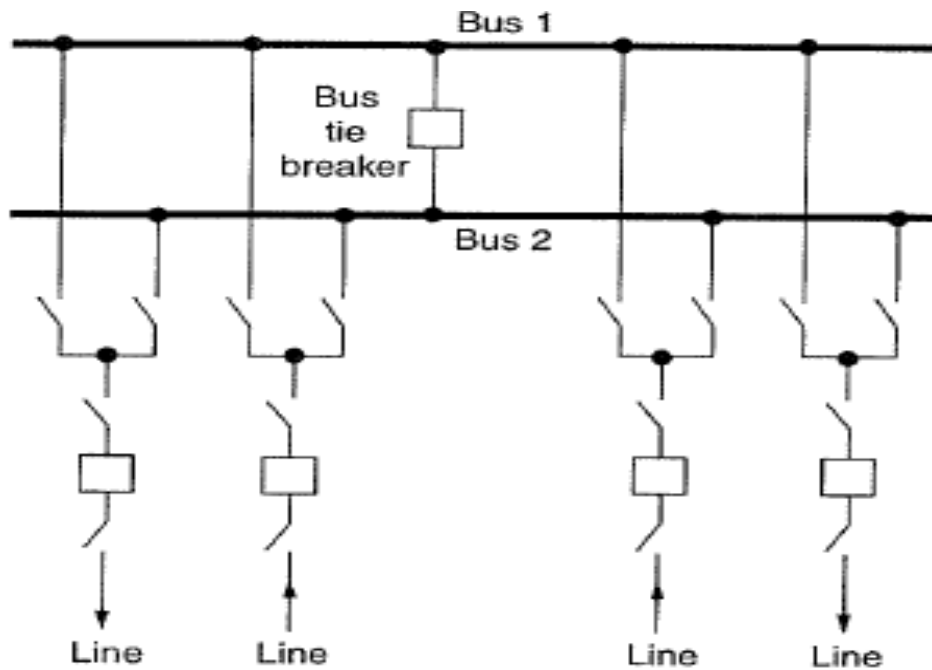

A typical double bus-single breaker scheme.

**Switching Scheme**

**Advantages**

**Disadvantages**

Double bus-single breaker

1. Permits some flexibility with two operating buses.
2. Either main bus may be isolated for maintenance.
3. Circuit can be transferred readily from one bus to the other by use of bus-tie breaker and bus selector disconnect switches.

1. One extra breaker is required for the bus tie.
2. Four switches are required per circuit.
3. Bus protection scheme may cause loss of substation when it operates if all circuits are connected to that bus.
4. High exposure to bus faults.
5. Line breaker failure takes all circuits connected to that bus out of service.
6. Bus-tie breaker failure takes entire substation out of service.

(v) ring bus scheme;

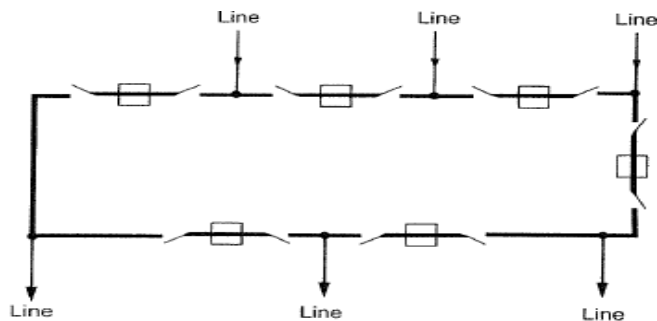

A typical ring bus scheme.

**Switching Scheme****Advantages****Disadvantages**

Ring bus

1. Low initial and ultimate cost.
2. Flexible operation for breaker maintenance.
3. Any breaker can be removed for maintenance without interrupting load.
4. Requires only one breaker per circuit.
5. Does not use main bus.
6. Each circuit is fed by two breakers.
7. All switching is done with breakers.

1. If a fault occurs during a breaker maintenance period, the ring can be separated into two sections.
2. Automatic reclosing and protective relaying circuitry rather complex.
3. If a single set of relays is used, the circuit must be taken out of service to maintain the relays (common on all schemes).
4. Requires potential devices on all circuits since there is no definite potential reference point. These devices may be required in all cases for synchronizing, live line, or voltage indication.
5. Breaker failure during a fault on one of the circuits causes loss of one additional circuit owing to operation of breaker-failure relaying.

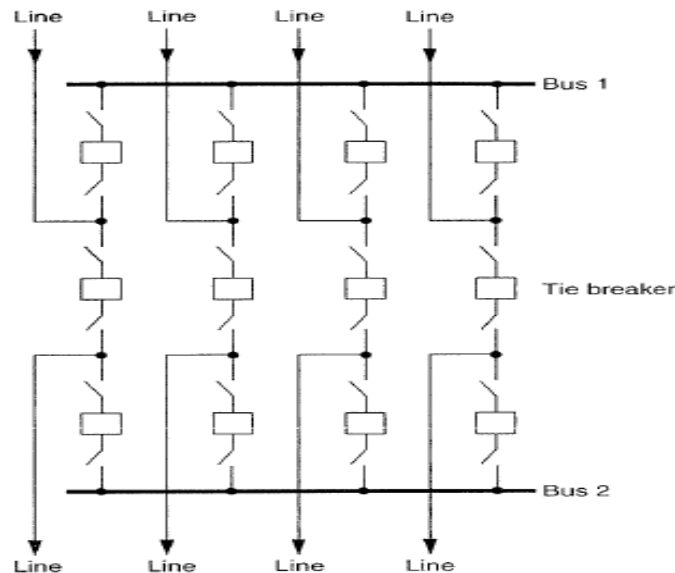
**(vi) breaker-and-a-half scheme.**

A typical breaker-and-a-half scheme.

**Switching Scheme****Advantages****Disadvantages**

Breaker-and-a-half

1. Most flexible operation.
2. High reliability.
3. Breaker failure of bus side breakers removes only one circuit from service.
4. All switching is done by breakers.
5. Simple operation; no disconnect switching required for normal operation.
6. Either main bus can be taken out of service at any time for maintenance.
7. Bus failure does not remove any

1. 1½ breakers per circuit.
2. Relaying and automatic reclosing are somewhat involved since the middle breaker must be responsive to either of its associated circuits.

# UNIT 4

## POWER FACTOR IMPROVEMENT

## Unit IV

### VOLTAGE DROP AND POWER CALCULATIONS FOR A THREE-PHASE BALANCED PRIMARY LINES

#### RADIAL FEEDERS WITH UNIFORMLY DISTRIBUTED LOAD

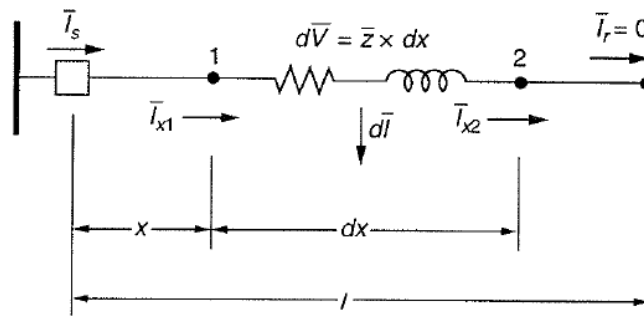

FIGURE 5.25 A radial feeder.

The single-line diagram, shown in Figure 5.25, illustrates a three-phase feeder main having the same construction, that is, in terms of cable size or open-wire size and spacing, along its entire length  $l$ . Here, the line impedance is  $z = r + jx$  per unit length.

The load flow in the main is assumed to be perfectly balanced and uniformly distributed at all locations along the main. In practice, a reasonably good phase balance sometimes is realized when single-phase and open-wye laterals are wisely distributed among the three phases of the main.

Assume that there are many closely spaced loads and/or lateral lines connected to the main but not shown in Figure 5.25. Since the load is uniformly distributed along the main, as shown in Figure 5.26, the load current in the main is a function of the distance. Therefore, in view of the many closely spaced small loads, a differential tapped-off load current  $d\bar{I}$ , which corresponds to a  $dx$  differential distance, is to be used as an idealization. Here,  $l$  is the total length of the feeder and  $x$  is the distance of the point 1 on the feeder from the beginning end of the feeder. Therefore, the distance of point 2 on the feeder from the beginning end of the feeder is  $x + dx$ .  $\bar{I}_s$  is the sending-end current at the feeder breaker, and  $\bar{I}_r$  is the receiving-end current.  $\bar{I}_{x1}$  and  $\bar{I}_{x2}$  are the currents in the main at points 1 and 2, respectively. Assume that all loads connected to the feeder have the same power factor.

The following equations are valid both in per unit or per phase (line-to-neutral) dimensional variables. The circuit voltage is either primary or secondary, and therefore shunt capacitance currents may be neglected.

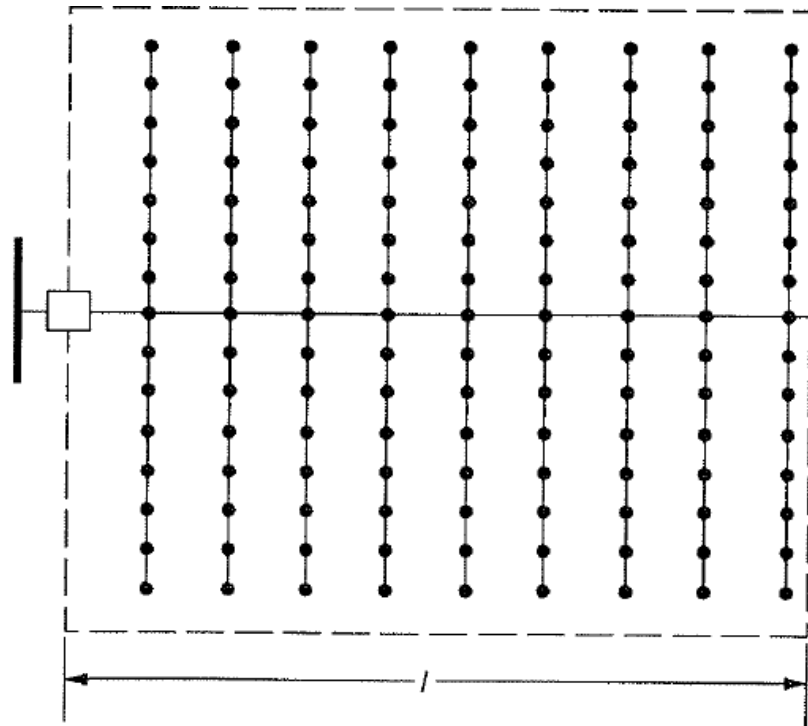

**FIGURE 5.26** A uniformly distributed main feeder.

As the total load is uniformly distributed from  $x = 0$  to  $x = l$ ,

$$\frac{d\bar{I}}{dx} = \bar{k}, \quad (5.8)$$

which is a constant.

Therefore  $\bar{I}_x$ , that is, the current in the main of some  $x$  distance away from the circuit breaker, can be found as a function of the sending-end current  $\bar{I}_S$  and the distance  $x$ . This can be accomplished either by inspection or by writing a current equation containing the integration of the  $d\bar{I}$ . Therefore, for the  $dx$  distance,

$$\bar{I}_{x1} = \bar{I}_{x2} + d\bar{I} \quad (5.9)$$

or

$$\bar{I}_{x2} = \bar{I}_{x1} - d\bar{I}. \quad (5.10)$$

From Equation 5.10,

$$\begin{aligned}\bar{I}_{x2} &= \bar{I}_{x1} - d\bar{I} \frac{dx}{dx} \\ &= \bar{I}_{x1} - \frac{d\bar{I}}{dx} dx\end{aligned}\tag{5.11}$$

or

$$\bar{I}_{x2} = \bar{I}_{x1} - \bar{k}dx\tag{5.12}$$

where

$$\bar{k} = \frac{d\bar{I}}{dx}$$

or, approximately,

$$\bar{I}_{x2} = \bar{I}_{x1} - kd\bar{I}\tag{5.13}$$

and

$$\bar{I}_{x1} = \bar{I}_{x2} + kd\bar{I}\tag{5.14}$$

Therefore, for the total feeder,

$$I_r = I_s - k \times l\tag{5.15}$$

and

$$I_s = I_r + k \times l.\tag{5.16}$$

When  $x = l$ , from Equation 5.15,

$$I_r = I_s - k \times l = 0$$

hence

$$k = \frac{I_s}{l}\tag{5.17}$$

and since  $x = l$ ,

$$I_r = I_s - k \times x.\tag{5.18}$$

Therefore, substituting Equation 5.17 into Equation 5.18,

$$I_r = I_s \left(1 - \frac{x}{l}\right).\tag{5.19}$$

For a given  $x$  distance,

$$I_x = I_r$$

thus Equation 5.19 can be written as:

$$I_x = I_s \left( 1 - \frac{x}{l} \right), \quad (5.20)$$

which gives the current in the main at some  $x$  distance away from the circuit breaker. Note that from Equation 5.20,

$$I_s = \begin{cases} I_r = 0 & \text{at } x = l \\ I_r = I_s & \text{at } x = 0. \end{cases}$$

The differential series voltage drop  $d\bar{V}$  and the differential power loss  $dP_{LS}$  because of  $I^2R$  losses can also be found as a function of the sending-end current  $I_s$  and the distance  $x$  in a similar manner.

Therefore, the differential series voltage drop can be found as:

$$d\bar{V} = I_x \times z dx \quad (5.21)$$

or substituting Equation 5.20 into Equation 5.21,

$$d\bar{V} = I_s \times z \left( 1 - \frac{x}{l} \right) dx. \quad (5.22)$$

Also, the differential power loss can be found as:

$$dP_{LS} = I_x^2 \times r dx \quad (5.23)$$

or substituting Equation 5.20 into Equation 5.23,

$$dP_{LS} = \left[ I_s \left( 1 - \frac{x}{l} \right) \right]^2 r dx \quad (5.24)$$

The series voltage drop  $VD_x$  because of  $I_x$  current at any point  $x$  on the feeder is

$$VD_x = \int_0^x dV. \quad (5.25)$$

Substituting Equation 5.22 into Equation 5.25,

$$VD_x = \int_0^x I_s \times z \left( 1 - \frac{x}{l} \right) dx \quad (5.26)$$



or

$$VD_x = I_s \times z \times x \left(1 - \frac{x}{2l}\right). \quad (5.27)$$

Therefore, the total series voltage drop  $\sum VD_x$  on the main feeder when  $x = l$  is:

$$\sum VD_x = I_s \times z \times l \left(1 - \frac{1}{2l}\right)$$

or

$$\sum VD_x = \frac{1}{2} z \times l \times I_s. \quad (5.28)$$

The total copper loss per phase in the main because of  $I^2R$  losses is:

$$\sum P_{LS} = \int_0^l dP_{LS} \quad (5.29)$$

or

$$\sum P_{LS} = \frac{1}{3} I_s^2 \times r \times l \quad (5.30)$$

Therefore, from Equation 5.28, the distance  $x$  from the beginning of the main feeder at which location the total load current  $I_s$  may be concentrated, that is, lumped for the purpose of calculating the total voltage drop, is

$$x = \frac{l}{2}$$

whereas, from Equation 5.30, the distance  $x$  from the beginning of the main feeder at which location the total load current  $I_s$  may be lumped for the purpose of calculating the total power loss is

$$x = \frac{l}{3}$$

## CAUSES OF LOW POWER FACTOR

Low power factor is undesirable from an economic point of view. Normally, the power factor of the whole load on the supply system is lower than 0.8.

The following are the causes of low power factor:

(i) Most of the a.c. motors are of induction type (1 and 3 induction motors) which have low lagging power factor. These motors work at a power factor which is extremely small on light load (0.2 to 0.3) and rises to 0.8 or 0.9 at full load.

(ii) Arc lamps, electric discharge lamps and industrial heating furnaces operate at low lagging power factor.

(iii) The load on the power system is varying; being high during morning and evening and low at other times. During low load period, supply voltage is increased which increases the magnetization current. This results in the decreased power factor.

## Most Economical Power Factor

If a consumer improves the power factor, there is reduction in his maximum kVA demand and hence there will be annual saving over the maximum demand charges. However, when power factor is improved, it involves capital investment on the power factor correction equipment. The consumer will incur expenditure every year in the shape of annual interest and depreciation on the investment made over the p.f. correction equipment. Therefore, the *net annual saving* will be equal to the annual saving in maximum demand charges *minus* annual expenditure incurred on p.f. correction equipment.

The value to which the power factor should be improved so as to have maximum net annual saving is known as the **most economical power factor**.

Consider a consumer taking a peak load of  $P$  kW at a power factor of  $\cos \phi_1$  and charged at a rate of  $R_s$  x per kVA of maximum demand per annum. Suppose the consumer improves the power factor to  $\cos \phi_2$  by installing p.f. correction equipment. Let expenditure incurred on the p.f. correction equipment be  $R_s$  y per kVAR per annum. The power triangle at the original p.f.  $\cos \phi_1$  is  $OAB$  and for the improved p.f.  $\cos \phi_2$ , it is  $OAC$  [See Fig. 6.13].

$$\text{kVA max. demand at } \cos \phi_1, \text{ kVA}_1 = P / \cos \phi_1 = P \sec \phi_1$$

$$\text{kVA max. demand at } \cos \phi_2, \text{ kVA}_2 = P / \cos \phi_2 = P \sec \phi_2$$

Annual saving in maximum demand charges

$$= R_s x (\text{kVA}_1 - \text{kVA}_2)$$

$$= R_s x (P \sec \phi_1 - P \sec \phi_2)$$

$$= R_s x P (\sec \phi_1 - \sec \phi_2) \quad \dots(i)$$

$$\text{Reactive power at } \cos \phi_1, \text{ kVAR}_1 = P \tan \phi_1$$

$$\text{Reactive power at } \cos \phi_2, \text{ kVAR}_2 = P \tan \phi_2$$

Leading kVAR taken by p.f. correction equipment

$$= P (\tan \phi_1 - \tan \phi_2)$$

Annual cost of p.f. correction equipment

$$= R_s P y (\tan \phi_1 - \tan \phi_2) \quad \dots(ii)$$

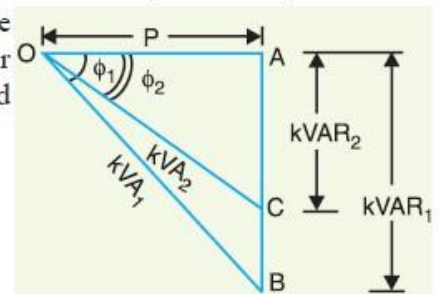

Fig. 6.13

$$\begin{aligned} \text{Net annual saving, } S &= \text{exp. (i)} - \text{exp. (ii)} \\ &= xP (\sec \phi_1 - \sec \phi_2) - yP (\tan \phi_1 - \tan \phi_2) \end{aligned}$$

In this expression, only  $\phi_2$  is variable while all other quantities are fixed. Therefore, the net annual saving will be maximum if differentiation of above expression w.r.t.  $\phi_2$  is zero i.e.

$$\frac{d}{d\phi_2} (S) = 0$$

$$\text{or } \frac{d}{d\phi_2} [xP (\sec \phi_1 - \sec \phi_2) - yP (\tan \phi_1 - \tan \phi_2)] = 0$$

$$\text{or } \frac{d}{d\phi_2} (xP \sec \phi_1) - \frac{d}{d\phi_2} (xP \sec \phi_2) - \frac{d}{d\phi_2} (yP \tan \phi_1) + yP \frac{d}{d\phi_2} (\tan \phi_2) = 0$$

$$\text{or } 0 - xP \sec \phi_2 \tan \phi_2 - 0 + yP \sec^2 \phi_2 = 0$$

$$\text{or } -x \tan \phi_2 + y \sec \phi_2 = 0$$

$$\text{or } \tan \phi_2 = \frac{y}{x} \sec \phi_2$$

$$\text{or } \sin \phi_2 = y/x$$

$$\therefore \text{ Most economical power factor, } \cos \phi_2 = \sqrt{1 - \sin^2 \phi_2} = \sqrt{1 - (y/x)^2}$$

It may be noted that the most economical power factor ( $\cos \phi_2$ ) depends upon the relative costs of supply and p.f. correction equipment but is independent of the original p.f.  $\cos \phi_1$ .

## POWER FACTOR CORRECTION

A typical utility system would have a reactive load at 80% power factor during summer months. Therefore, in typical distribution loads, the current lags the voltage, as shown in Figure 8.7a. The cosine of the angle between current and sending voltage is known as the *power factor* of the circuit. If the in-phase and out-of-phase components of the current  $I$  is multiplied by the receiving-end voltage  $V_R$ , the resultant relationship can be shown on a triangle known as the *power triangle*, as shown in Figure 8.7b. Figure 8.7b shows the triangular relationship that exists between kilowatts, kilovoltamperes, and kilovars. Note that, by adding the capacitors, the reactive power component  $Q$  of

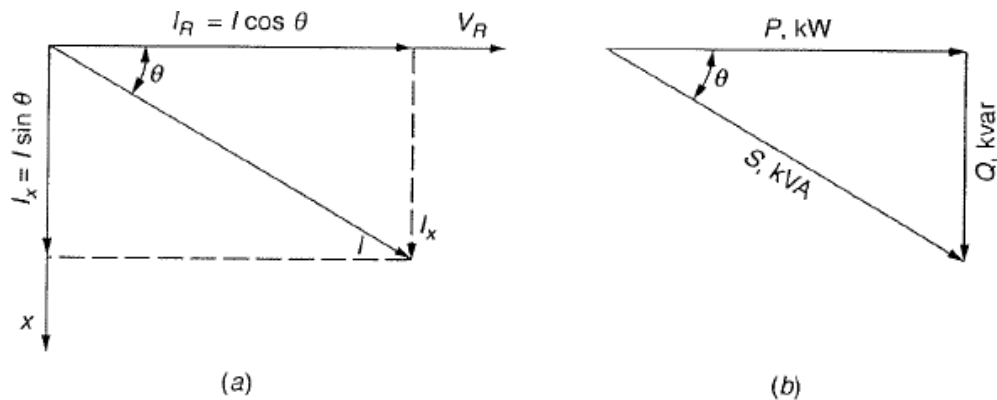
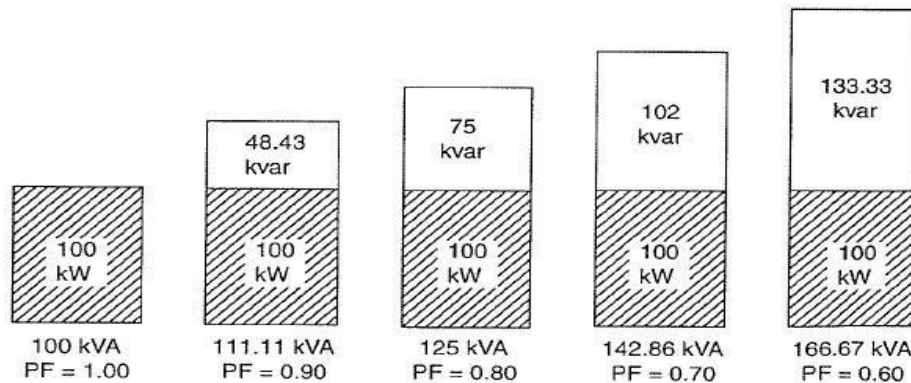

FIGURE 8.7 (a) Phasor diagram and (b) power triangle for a typical distribution load.

the apparent power  $S$  of the load can be reduced or totally suppressed. Figures 8.8 and 8.9 illustrate how the reactive power component  $Q$  increases with each 10% change of power factor. Note that, as illustrated in Figure 8.8, even an 80% power factor of the reactive power (kilovar) size is quite large, causing a 25% increase in the total apparent power (kilovoltamperes) of the line. At this power factor, 75 kvar of capacitors is needed to cancel out the 75 kvar of lagging component.

As previously mentioned, the generation of reactive power at a power plant and its supply to a load located at a far distance is not economically feasible, but it can easily be provided by capacitors located at the load centers. Figure 8.10 illustrates the power factor correction for a given system. As illustrated in the figure, capacitors draw leading reactive power from the source; that is, they supply lagging reactive power to the load. Assume that a load is supplied with a real power  $P$ , lagging reactive power  $Q_1$ , and apparent power  $S_1$  at a lagging power factor of



**FIGURE 8.8** Illustration of the required increase in the apparent and reactive powers as a function of the load power factor, holding the real power of the load constant.

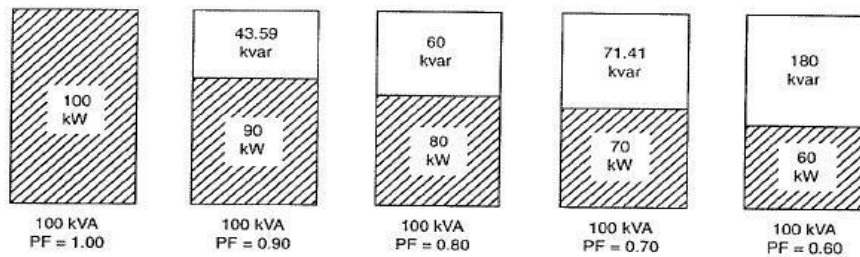

**FIGURE 8.9** Illustration of the change in the real and reactive powers as a function of the load power factor, holding the apparent power of the load constant.

When a shunt capacitor of  $Q_c$  kVA is installed at the load, the power factor can be improved from  $\cos \theta_1$  to  $\cos \theta_2$ , where

$$\begin{aligned} \cos \theta_2 &= \frac{P}{S_2} \\ &= \frac{P}{(P^2 - Q_1^2)^{1/2}} \end{aligned}$$

or

$$\cos \theta_2 = \frac{P}{[P^2 + (Q_1 - Q_c)^2]^{1/2}} \quad (8.9)$$

Therefore, as can be observed from Figure 8.10b, the apparent power and the reactive power are decreased from  $S_1$  kVA to  $S_2$  kVA and from  $Q_1$  kvar to  $Q_2$  kvar (by providing a reactive power of  $Q$ ), respectively. The reduction of reactive current results in a reduced total current, which in turn causes less power losses. Thus the power factor correction produces economic savings in capital expenditures and fuel expenses through a release of kilovoltampere capacity and reduction of power losses in all the apparatus between the point of installation of the capacitors and the source power plants, including distribution lines, substation transformers, and transmission lines. The economic power factor is the point at which the economic benefits of adding shunt capacitors just equals the cost of the capacitors. In the past, this economic power factor was around 95%. Today's high plant and fuel costs have pushed the economic power factor toward unity. However, as the corrected power factor moves nearer to unity, the effectiveness of capacitors in improving the power

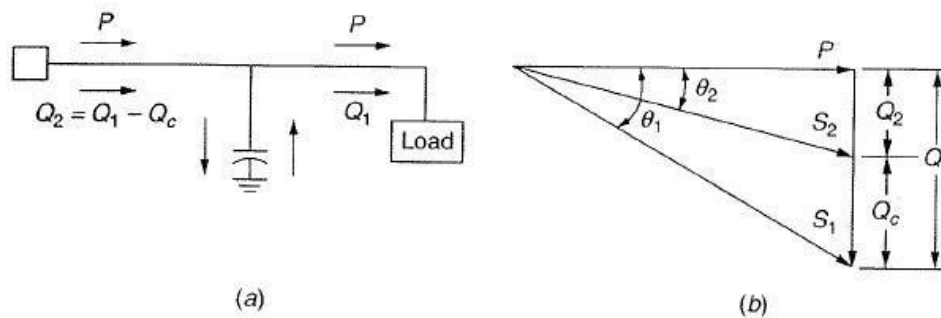

FIGURE 8.10 Illustration of power factor correction.

factor, decreasing the line kilovoltamperes transmitted, increasing the load capacity, or reducing line copper losses by decreasing the line current sharply decreases. Therefore, the correction of power factor to unity becomes more expensive with regard to the marginal cost of capacitors installed.

Table 8.1 is a power factor correction table to simplify the calculations involved in determining the capacitor size necessary to improve the power factor of a given load from the original to the desired value. It gives multiplier to determine kvar requirement. It is based on the following formula:

$$Q = P(\tan \theta_{\text{orig}} - \tan \theta_{\text{new}})$$

$$= P \left( \sqrt{\frac{1}{\text{PF}_{\text{orig}}^2} - 1} - \sqrt{\frac{1}{\text{PF}_{\text{new}}^2} - 1} \right)$$

where  $Q$  is the required compensation in kvar,  $P$  is the real power in kW,  $\text{PF}_{\text{orig}}$  is the original power factor, and  $\text{PF}_{\text{new}}$  is the desired power factor.

Furthermore, in order to understand how the power factor of a device can be improved one has to understand what is taking place electrically. Consider an induction motor that is being supplied by the real power  $P$  and the reactive power  $Q$ . The real power  $P$  is lost whereas the reactive power  $Q$  is not lost. But, instead it is used to store energy in the magnetic field of the motor. Since the current is alternating, the magnetic field undergoes cycles of building up and breaking down. As the

field is building up, the reactive current flows from the supply or source to the motor. As the field is breaking down, the reactive current flows out of the motor back to the supply or source. In such application, what is needed is some type of device that can be used as a temporary storage area for

the reactive power when the magnetic field of the motor breaks down.

The ideal device for this is a *capacitor* which also stores energy. However, this energy is stored in an electric field. By connecting a capacitor *in parallel with the supply line of the load*, the cyclic flow of reactive power takes place between the motor and the capacitor. Here, the supply lines carry only the current supplying real power to the motor. *This is only applicable for a unity power factor condition.* For other power factors, the supply lines would carry some reactive power.

## ECONOMIC JUSTIFICATION FOR CAPACITORS

Loads on electric utility systems include two components: active power (measured in kilowatts) and reactive power (measured in kilovars). Active power has to be generated at power plants, whereas reactive power can be provided by either power plants or capacitors. It is a well-known fact that shunt power capacitors are the most economical sources to meet the reactive power requirements of inductive loads and transmission lines operating at a lagging power factor.

When reactive power is provided only by power plants, each system component (i.e., generators, transformers, transmission and distribution lines, switchgear, and protective equipment) has to be increased in size accordingly. Capacitors can mitigate these conditions by decreasing the reactive power demand all the way back to the generators. Line currents are reduced from capacitor locations all the way back to the generation equipment. As a result, losses and loadings are reduced in distribution lines, substation transformers, and transmission lines. Depending on the uncorrected power factor of the system, the installation of capacitors can increase generator and substation capability for additional load by at least 30% and can increase individual circuit capability, from the voltage regulation point of view, by approximately 30–100%. Furthermore, the current reduction in transformer and distribution equipment and lines reduces the load on these kilovoltampere-limited apparatus and consequently delays the new facility installations. In general, the economic benefits force capacitor banks to be installed on the primary distribution system rather than on the secondary.

It is a well-known *rule of thumb* that the optimum amount of capacitor kilovars to employ is always the amount at which the economic benefits obtained from the addition of the last kilovar exactly equals the installed cost of the kilovars of capacitors. The methods used by the utilities to determine the economic benefits derived from the installation of capacitors vary from company-to-company, but the determination of the total installed cost of a kilovar of capacitors is easy and straightforward.

In general, the *economic benefits that can be derived from capacitor installation* can be summarized as:

1. Released generation capacity.
2. Released transmission capacity.
3. Released distribution substation capacity.
4. Additional advantages in distribution system.
  - (a) Reduced energy (copper) losses.
  - (b) Reduced voltage drop and consequently improved voltage regulation.
  - (c) Released capacity of feeder and associated apparatus.
  - (d) Postponement or elimination of capital expenditure due to system improvements and/or expansions.
  - (e) Revenue increase due to voltage improvements.

## A PRACTICAL PROCEDURE TO DETERMINE THE BEST CAPACITOR LOCATION

In general, the best location for capacitors can be found by optimizing power loss and voltage regulation. A feeder voltage profile study is performed to warrant the most effective location for capacitors and the determination of a voltage which is within recommended limits. Usually, a 2-V rise on circuits used in urban areas and a 3-V rise on circuits used in rural areas are approximately the maximum voltage changes that are allowed when a switched capacitor bank is placed into operation. The general iteration process involved is summarized in the following steps:

1. Collect the following circuit and load information:
  - (a) Any two of the following for each load: kilovoltamperes, kilovars, kilowatts, and load power factor,
  - (b) Desired corrected power of circuit,
  - (c) Feeder circuit voltage,
  - (d) A feeder circuit map which shows locations of loads and presently existing capacitor banks.
2. Determine the kilowatt load of the feeder and the power factor.
3. From Table 8.1, determine the kilovars per kilowatts of load (i.e., the correction factor) necessary to correct the feeder circuit power factor from the original to the desired power factor. To determine the kilovars of capacitors required, multiply this correction factor by the total kilowatts of the feeder circuit.
4. Determine the individual kilovoltamperes and power factor for each load or group of loads.
5. To determine the kilovars on the line, multiply individual load or groups of loads by their respective reactive factors that can be found from Table 8.1.
6. Develop a nomograph to determine the line loss in watts per thousand feet due to the inductive loads tabulated in steps 4 and 5. Multiply these line losses by their respective line lengths in thousands of feet. Repeat this process for all loads and line sections and add them to find the total inductive line loss.
7. In the case of having presently existing capacitors on the feeder, perform the same calculations as in step 6, but this time subtract the capacitive line loss from the total inductive line loss. Use the capacitor kilovars determined in step 3 and the nomograph developed for step 6 and find the line loss in each line section due to capacitors.
8. To find the distance to capacitor location, divide total inductive line loss by capacitive line loss per thousand feet. If this quotient is greater than the line section length
  - (a) Divide the remaining inductive line loss by capacitive line loss in the next line section to find the location;
  - (b) If this quotient is still greater than the line section length, repeat step 8a.
9. Prepare a voltage profile by hand calculations or by using a computer program for voltage profile and load analysis to determine the circuit voltages. If the profile shows that the voltages are inside the recommended limits, then the capacitors are installed at the location of minimum loss. If not, then use engineering judgment to locate them for the most effective voltage control application.

UNIT 5

DISTRIBUTION AUTOMATION



## UNIT5

### **Distribution Automation (DA)**

#### **5.1 Distribution Automation (DA)**

It is an integrated system concept for the digital automation of distribution sub-station, feeder and user functions. It includes control, monitoring and protection of the distribution system, load management and remote metering of consumer loads.

The distribution automation contains:

- Computer Hardware
- Computer Software
- Remote Terminal Units (RTUs)
- Communication Systems
- Consumer Metering Devices.

The benefits of DA are:

- Improved quality of supply
- Improved continuity of supply
- Voltage level stability
- Reduced system losses
- Reduced investment

The distribution automation system provides automatic reclosing of relays, automatic feeder switching and provides remote monitoring and controlling of distribution equipment (transformers, capacitors, breakers, sectionalizers, communication nodes etc.) from sub-station up to and including the consumer interface. It affords the utility in minimizing outage time and ultimately, better consumer service and lowering of the total delivered cost of electricity. It allows operation of the system with less capacity margin. The technical aspects of distribution automation are complex and need a thorough examination for their planning.

The various functions DA can be:

- Electrical network analysis
- Work management
- Trouble call analysis

- Consumer load monitoring
- Intelligent remote metering e.g. automatic meter reading etc.
- Automated capacitor control
- Sub-station automation
- Intelligent electric devices
- Advanced remote terminal units
- Computerized power distribution relays
- Power quality monitoring
- Automated Mapping (AM)/Facilities Management (FM)/Geographical Information System (GIS).
- Energy Management

## 5.2 Project Planning

Rigorous project planning and management practices should be applied to complete the work in time and within the budget. The automation schemes should be constructed on a turn-key basis from a capable vendor with maintenance and training contracts for a year or two initially.

The project plan should contain:

- A detailed schedule of all project activities and their estimated durations.
- A statement on the methods to be used to complete all the project activities.
- A quality statement which identifies all quality control and quality assurance steps to be applied.
- The structure of database is most critical to the integrated function of Distribution Management System (see Fig. 5.1). The choice of

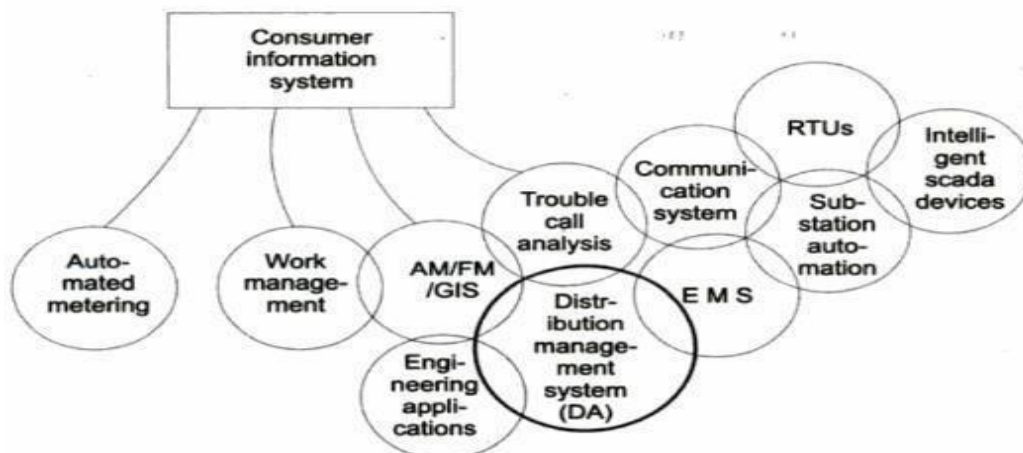

**Fig. 5.1**

*Typical distribution automation integration*

Data Base Management System is important for any SCADA/EMS etc. to assure consistency of information over the telecontrol system [18].

- \* A statement on the organisation requirements and impacts within the utility organisation, to effectively manage the data capture/conversion process, and to maintain the data in an upto date.

## Definitions

- **Automation Switching Controls:** Some of these are as follows:
  - (a) **Outdoor Lighting Controls:** Local electro-magnetic relay or electronic and/or thermal/time delay relay with photoelectric controls.
  - (b) **Line or Capacitor Switching Controls:** Local control by time, temperature, current, voltage and VAr. Remote control by VHF/UHF radio.
  - (c) **Line Post Sensors:** SCADA and local feeder monitoring for load switching and fault information.
  - (d) **Faulted Circuit Indications:** Fault location through use of on site LED, fluorescent flag, and remote SCADA indication for single-phase or three-phase overhead, underground or padmounted transformers.
  - (e) **Radio Switches:** Peak power demand reduction through VHF/UHF radio switching of consumer or feeder load.
- **Ethernet:** A popular network protocol and cabling scheme with a transfer rate of 10 megabits per second, originally developed by Xerox in 1976. Ethernet uses a bus topology capable of connecting up to 1024 PCs and workstations within each main branch. Network nodes are connected by either using thick or thin coaxial cable, or by twisted-pair wiring. Ethernet user Carriers Sense Multiple Access/Collision Detection (CSMA/CD) to prevent network failures or collisions when two devices try to access the network at the same time.
- **Information Technology (IT):** It includes administrative computing and all 'end-user' computing of a business and technical nature. The term extends to smart or intelligent, programmable electronic devices used in power operations, from the generation of electricity (with computer-based distributed plant control systems) to power distribution automation (including applications of such technologies as automated mapping systems, SCADA, EMS etc.

- **LAN:** A group of computers and associated peripherals connected by a communications channel capable of sharing files and the resources between several users.
- **Management Information Systems:** Most often defined in the power utility industry, as the department responsible for administrative computing systems and operations.
- **Man Machine Interface (MMI):** It is interface between man and technology for control of the technical process. The computer system at Master Control Centre or Central Control Room Integrates with RTU over the communication link with its transmission protocol, acquires the remote sub-station or distribution transformer/Feeder data and transfers the same to the computer system for MMI. Figure 5.2 shows the flow-diagram for Man Machine Interface for the power system. The software is configured in a manner that makes the single-line diagram of the distribution system. The entire system can be monitored and controlled from the screen.
- **Modem:** The word is a contraction of Modulator/DE Modulator. Modulation is the conversion of digital bit streams into analog telemetry suitable for transmission. Demodulation is the reverse of that process. The modem is a device that allows a computer to transmit information over a suitable communication link, such as a telephone line. It translates the digital signals that the computer uses to analog signals suitable for transmission over the communication link. A suitable communication programme is needed to operate the modem.
- **Packet:** This includes any block of data sent over a network. Each pack contains information about the sender, receiver and error control information, in addition to the actual message. Packet switching is a data transmission method and simultaneously sends data packets from many sources over the same communication channel. Packet-switching networks are considered fast and efficient. Standards for packet switching on networks are documented in the CCITT recommendation X.25.
- **Protocol:** In computer lingo, a protocol is that which allows two computers to understand each other while transferring information between themselves. In networking and communications, it is the specification that defines the procedures to follow when transmitting data. Software products from different vendors can communicate on the same network if they use the same protocol. This is software handshaking.

- **Router:** In networking, an intelligent connecting device that can send packets to the correct LAN segments to take them to their destination.
- **Remote Terminal Units (RTUs):** Modern RTUs are microprocessor based devices and are designed to acquire data and transfer the same to the Master Station through a communication link radio, power line carrier, wire, fibre optic etc. RTUs collect data from transducers, transmitters, contact inputs from equipment/instruments, meter readings etc., perform analogue/digital conversions, check data-scaling and corrections (typically at I/O card level), perform pre-processing tasks and send/receive messages from/to master station(s) via interfaces.

The RTU for a transformer has the following functions:

- (i) Data exchange between the communication line to the master station and low voltage line RTU for consumers.
  - (ii) Automatic data polling to RTU for consumers. RTU for the
  - **Workstation:** The role of the Workstation is to serve as an intelligent window to the database. It is a high performance computer. It is used to:
    - Provide a simple user interface for indexing the data.
    - Form the database access commands.
    - Communicate with the server database.
    - Accept the data are returned from the database.
    - Display the data graphically.
- consumer has the following functions:
- (i) Remote meter reading.
  - (ii) Load control.
  - (iii) Display of information for the consumer.

A typical installation of the RTU for consumer automation is shown in Fig. 5.3. Various companies in India have developed the RTU for DAS such as Global, Shyam, ABB, GEC, CMC, EMCO, Siemens etc.

## Communication

There are many communication methods available. Evaluation of different communication systems for data communication between Distribution Control Centre (DCC) and any point on the distribution network is required at the planning stage. The fundamental requirements for communication infrastructure are:

- (i) Determination of system average message rate;
- (ii) If it can handle the requisite amount of data and multitasking;
- (iii) Data throughput and system response times should meet various application requirements;
- (iv) It should allow for network growth and added applications.

The communication methods may be used individually or combined.

### **1 Public Switched Telephone Network (PSTN)**

### **2 Power-Line Carrier (PLC)**

#### ***(a) Ripple Control***

#### ***(b) Cyclocontrol***

#### ***(c) Carrier Frequency***

### **3 Radio Communication**

#### ***(a) UHF Point-to-point Radio***

#### ***(b) UHF Multi Address System Radio***

#### ***(c) VHF Radio***

#### ***(d) Packet Switching Network (PSN)***

#### ***(e) Cellular Radio***

### **4 Fibre Optics**

### **5 Satellite Communication**

## **Sensors**

---

Line sensors can be provided at line poles or towers which acquire data, such as phase currents and phase voltages and can also detect short circuit and grounding faults.

basic sensors may be current transformer, voltage transformer relay, level gauge, pressure gauge, flow metre, bimetallic temp. element etc.

### ***Transmitter***

This provides output (transmittable) signals after converting and amplifying low level signals of basic sensor elements. Modern transmitters are smart and microprocessor based, performing many other functions such as alarm, signal etc.

### ***Transducer***

This is a measuring element that senses the external action. It gathers parameters and supplies through remote telecommunication capabilities. Conversion components are often classified as *sensors* or as *transducers*. The difference is often blurred, but in essence, a sensor converts from one form of energy to another with no regard to efficiency and is generally used for measurement purposes. A transducer is used where the efficiency of transfer is more important, as in control systems. Transducers measure non-electrical quantities and convert them into electrical quantities. The commonly used transducers are photo-cell, hall-effect fluxmeter, microphone, thermocouple, thermistor, Resistance Temperature Detector (RTD), potentiometer, piezo-electric, piezo-resistive, capacitance, electronic bridge-circuit, strain-gauge and programmable power transducer (for real-time feeder telemetry data) etc. [5].

### ***Receiver***

In two way communication, the Receiver is used as terminal equipment along with the transmitter.

## **Supervisory Control and Data Acquisition (SCADA)**

Distribution SCADA (see Sec. 4.13) supervises the distribution system.

The application areas of SCADA can essentially be categorized into the following groups:

- Small SCADA systems with a selected number of functions, e.g. for distribution networks and for electrical networks of industrial complexes.
- Medium-size SCADA and EMS with the full spectrum of functions for distribution and subtransmission networks, and selected functions for generation.
- Large-scale SCADA and EMS with an extensive and sophisticated range of functions for transmission networks and generation.

The various components of SCADA are shown in Fig. 5.12.

When interfacing and RTU to existing equipment, the following aspects may be considered.

- Availability of potential free contacts and motor drives or actuators.
- Wiring and marshalling.
- Interposing relays may eventually be required.
- Measurement transducers.
- Buffered power supply.

When building a new sub-station, the integration of the RTU functions into a microprocessor based station control system is desirable, since multiple cabling between the signal sources and the different systems for protection, local control and remote control can be avoided.

### **Hardware and Software**

A typical SCADA system comprises the hardware and the software.

#### ***Hardware***

The hardware may consist of:

- User-friendly man-machine interface
- Work-station
- Servers having a particular function
- Communication sub-system
- Peripherals
- RTUs.



All the above components communicate with each other via a Local Area Network (LAN) with internationally standardised protocols.

A flexible redundancy is provided, assigning hot stand-by servers to any server fulfilling time critical functions.

### ***Software***

A thorough understanding of available packages, operating systems, database access standards, user interface standards and systems integration techniques is essential to provide solutions to meet specific requirements. Also vital are high calibre staff and established policies, procedures and techniques for software engineering, project management and quality assurance.

Generally, experienced inhouse groups or external services are capable of maintaining and enhancing application programmes for distribution automation such as for SCADA, AM/FM/GIS, CIS etc. Procurement of new programmes and major upgrades are often assisted by specialized consultants. There are national and international suppliers' markets for a broad range of softwares. An international standard, SPICE, enables the purchaser to assess the relative capabilities of software suppliers and the risk involved in selecting them. Artificial Intelligence (AI) methodology is different from usual programming and normally, special skills are needed for applying AI tools or shells and setting-up and maintaining the knowledge base. This situation will be improved once the application of AI techniques becomes common and the skills of the maintenance teams are developed.

## **Consumer Information Service (CIS)**

---

In India, consumer service is mostly done in the manner of 'fire fighting', i.e., it is complaint based. Consumers want fast, accurate and cost-effective service. CIS package services the following functions for better service to the consumer:

- Consumer information
- Account management
- Service orders
- Field service
- New business
- Meter reading
- Service rates
- Billing
- Accounts receivable
- Credit, deposits and budgets
- Collections
- Workflow management
- Website management

CIS application programmes are normally utility specific and should be developed inhouse or the standard package may require more of customization.

Account management maintains information describing service accounts and consumer accounts. CIS also maintains relationships between service accounts, consumer accounts and the consumers. Field service manages the scheduling, assignments and execution of field service orders. The field work includes new works, utility service and metre orders, complaint attendance orders, distribution service orders and investigation orders. The field service orders support the scheduling and execution of consumer requests for service, identification of available work dates for order scheduling, assignment of service personnel, dispatching of workteams and tracking the progress of each service order. Workflow management routes, analyzes, and distributes work in the system to appropriate functions, individuals and process. Work is broadly defined, encompassing orders, correspondence, information to be reviewed, revenue collection of defaulting amount cases, billing exceptions and various other activities. An extensive on-line help system can be available within CIS for each feature. With special software, the telephone technology is installed to facilitate the helpdesk operations.

## **Geographical Information System (GIS)**

---

GIS stores distribution system records for the entire network, giving details of the age and position of sub-stations, lines and cables etc. Users can always know where their assets are and how they relate to each other.

Topological maps can be used for grid control i.e. load analysis, contingencies analysis; laying of cables, attending consumer complaints etc. The task of “digitising” power utility maps, and then to “vectorise” the digitised information so that roads, wires and other plant are recognised. Image processing and knowledge-based system techniques are used for automating this process.

Integrating geographical information systems into business support systems provides further benefits for an organisation. For example, emergency repairs would be carried out more efficiently if control room operators could send maps showing the location of equipment to maintenance staff.

The output of such analysis is always in bitmapping form. The GIS software package developed by the National Informatics Centre (NIC), is called GISNIC. The Geological Survey of India has a GIS mapping software which is capable of very high-level bit-mapping. GIS softwares have been developed by Infotech Enterprises, ISRO, RM Software India. GIS technology finds excellent use in facility mapping of power supply network.

## **Automatic Meter Reading (AMR)**

---

AMR is the remote collection of consumption data from the consumer’s power utility meter over a telephone line, radio system or power line carrier. AMR helps to:

- Improve billing accuracy
- Eliminate the need for estimating meter reading
- Shorten the time from consumption to billing and payment
- Improve load management
- Check tamper and leakage before it becomes a problem
- Increase the return on investment on a meter
- Provide remote connect and disconnect of the power connection
- Provide flexible tariff.

AMR comprises three elements:

- Automatic reading of meters
- A communication link between the meters and the central billing system
- A centralized information database on consumption.

Each AMR meter is provided with a transmitter/receiver module. It can read meters via a public switched telephone (PSTN), switched cellular, GPRS (Gross Packet Radio Service), GSM (Global Service for Mobile Communications) cellular connections etc. All these services are widely available in the country. About 10 per cent of AMR devices installed worldwide communicate by telephone and nearly 5 per cent by PLC. Radio is used in the remaining 85 per cent [17]. Radio is the least expensive technology for AMR. Radio AMR meter modules in the US generally operate at 900 MHz. In the UK, 184 MHz has been allocated for meter reading. In continental Europe, 433 MHz is the norm.

In the US, the radio band is shared with many users and spread spectrum modulation technique is encouraged. This system has been adopted in India. Certain environmental factors may require special considerations depending on where the meter is located. There may not be a clear path for the radio receiver in handheld computers, vehicles or pole-mounted units. Repeaters can be used to supplement such installations and are often needed in apartments, high-rise buildings or densely-populated city areas. Singapore Power uses a telephone line or GSM mobile telephone interface with RTU that reads the meter (records and stores pulses generated by the electricity meters) each day [11].

AMR software can have added value functions such as supervision of meters, operational conditions, detection of fraud attempts, consumer load profiles as per the standard: IEC 6206-31—data exchange for meter reading, tariff and load control.

## **Automation Systems**

The required function of distribution automation system varies with each application. The typical distribution automation systems composed of master station and the distribution equipment for feeder and consumer automation system is as shown in Fig. 5.14. The detail of equipment is shown in Table 5.1.

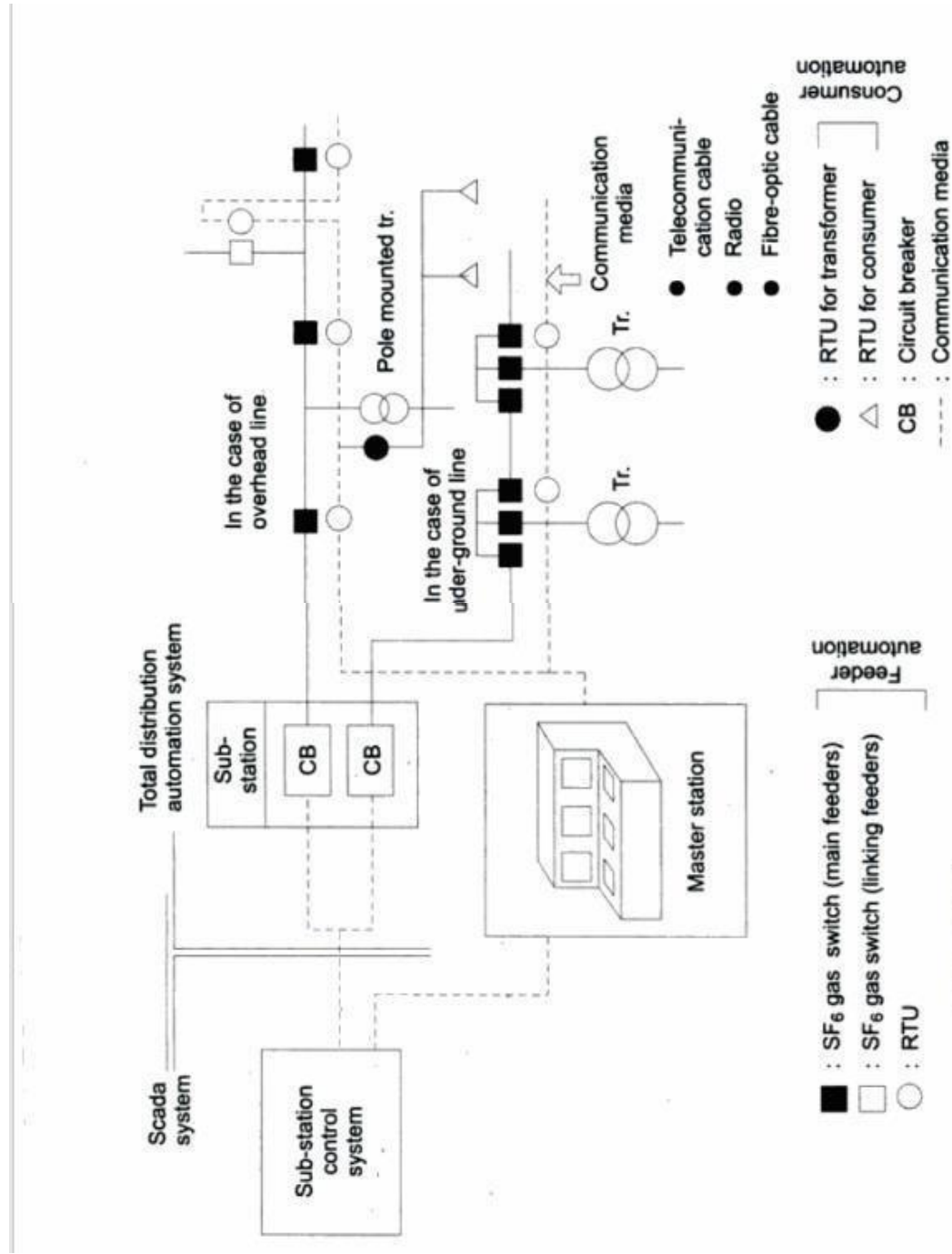

**Fig. 5.14**

*Typical distribution automation system*

**Table 5.1**

**Typical equipment of distribution automation system**

<i>Master station</i>	<i>Distribution equipment</i>	
	<i>Feeder automation</i>	<i>Consumer automation</i>
Work-station	Remote terminal unit (RTU)	RTU for transformer
Communication equipment	Remote-controlled SF <sub>6</sub> gas switch	RTU for consumer
Console or MMI	Line sensor Communication media	Communication media

Typically, the following three types of communication can be linked with the master station and RTU for feeder automation or RTU for transformer and for consumer automation:

- Telecommunication
- Radio communication
- Fibre optic communication

UNIT-1