

UNIT – I
INTRODUCTION TO MEASURING
INSTRUMENTS

1. Definition of instruments

An instrument is a device in which we can determine the magnitude or value of the quantity to be measured. The measuring quantity can be voltage, current, power and energy etc. Generally instruments are classified in to two categories.

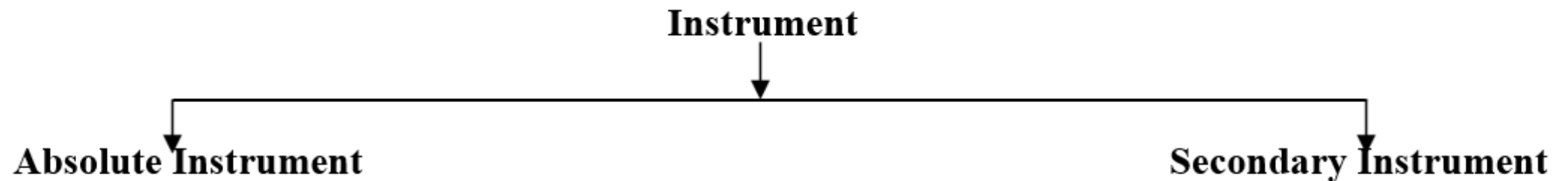

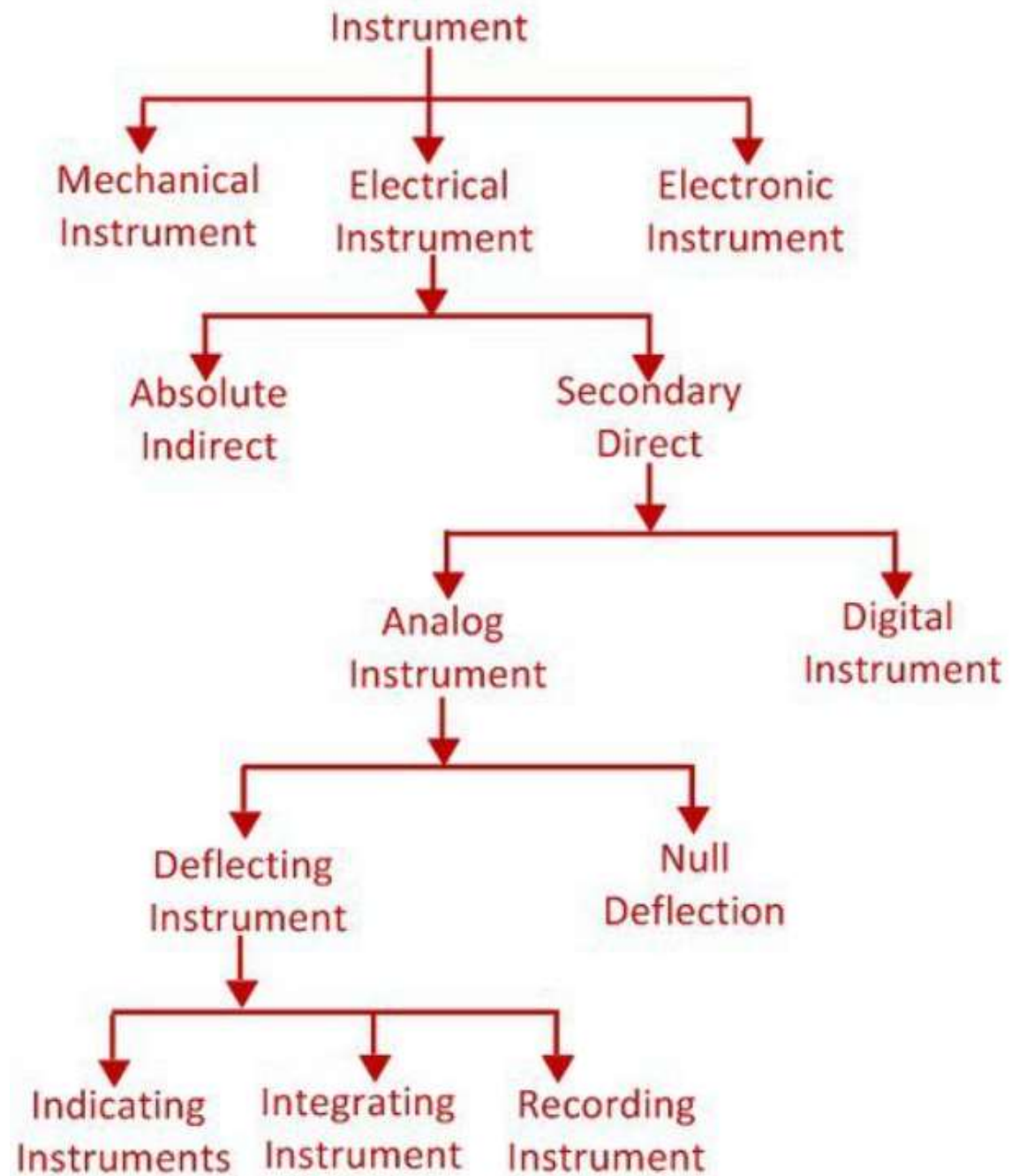

Absolute instrument

An absolute instrument determines the magnitude of the quantity to be measured in terms of the instrument parameter. This instrument is really used, because each time the value of the measuring quantities varies. So we have to calculate the magnitude of the measuring quantity, analytically which is time consuming. These types of instruments are suitable for laboratory use. Example: Tangent galvanometer.

Secondary instrument

This instrument determines the value of the quantity to be measured directly. Generally these instruments are calibrated by comparing with another standard secondary instrument.

Examples of such instruments are voltmeter, ammeter and wattmeter etc. Practically secondary instruments are suitable for measurement.

Functions of instrument and measuring system

- Functions of instrument and measuring system can be classified into three. They are:
 - i) Indicating function.
 - ii) Recording function.
 - iii) Controlling function.
- Application of measurement systems are:
 - i) Monitoring of process and operation.
 - ii) Control of processes and operation.
 - iii) Experimental engineering analysis.

Indicating instrument

This instrument uses a dial and pointer to determine the value of measuring quantity. The pointer indication gives the magnitude of measuring quantity.

Recording instrument

This type of instruments records the magnitude of the quantity to be measured continuously over a specified period of time.

Integrating instrument

This type of instrument gives the total amount of the quantity to be measured over a specified period of time.

Functional elements of a generalised measuring system

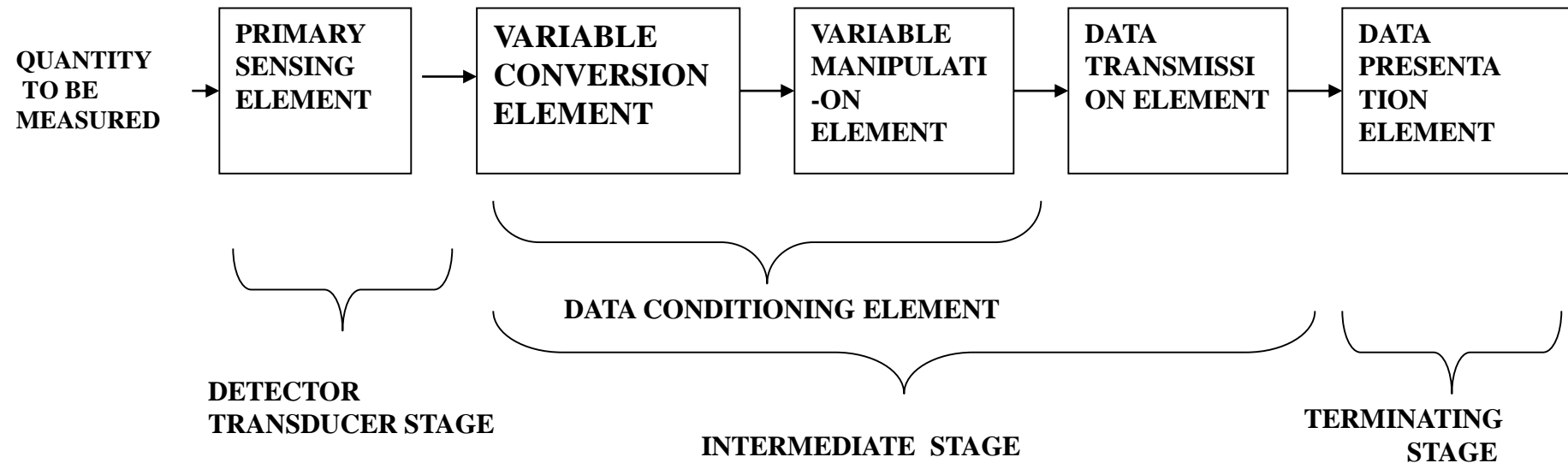

Principles and types of analog ammeter, voltmeter & multimeter

- **Analog Instruments**

- An analog device is one in which the output or display is a continuous function of time and bears a constant relation to its input

- **Classification**

- Classified based upon the quantity they measure (ammeter, voltmeter)
- Classified according to the current that can be measured by them.(DC,AC)
- Classified according to the effects used for working.
- Classified as Indicating, Recording, Integrating.
- Classified based on method used for comparing the unknown quantity. (Direct / Comparison measurement)

- **Essential requirements of an instrument:**
 - Deflecting system producing deflection torque T_d
 - Controlling system produces controlling torque T_c
 - Damping system producing damping torque
- **Deflecting system**
 - Deflecting system uses one of the following effects produced by current or voltage to produce deflection torque
 - Magnetic Effect.
 - Thermal Effect.
 - Electrostatic Effect
 - Induction Effect.
 - Hall Effect

- **Controlling system**

- There are two types of control system
 - Gravity control
 - Spring control

- **Damping system**

- The damping torque should be of such a magnitude that the pointer quickly comes to its final steady state position, without overshooting.
- To damp out the oscillation quickly, a damping force is necessary. This force is produced by different systems.
 - (a) Air friction damping
 - (b) Fluid friction damping
 - (c) Eddy current damping

Gravity control

This type of control consists of a small weight attached to the moving system whose position is adjustable. This weight produces a controlling torque due to gravity. This weight is called **control weight**.

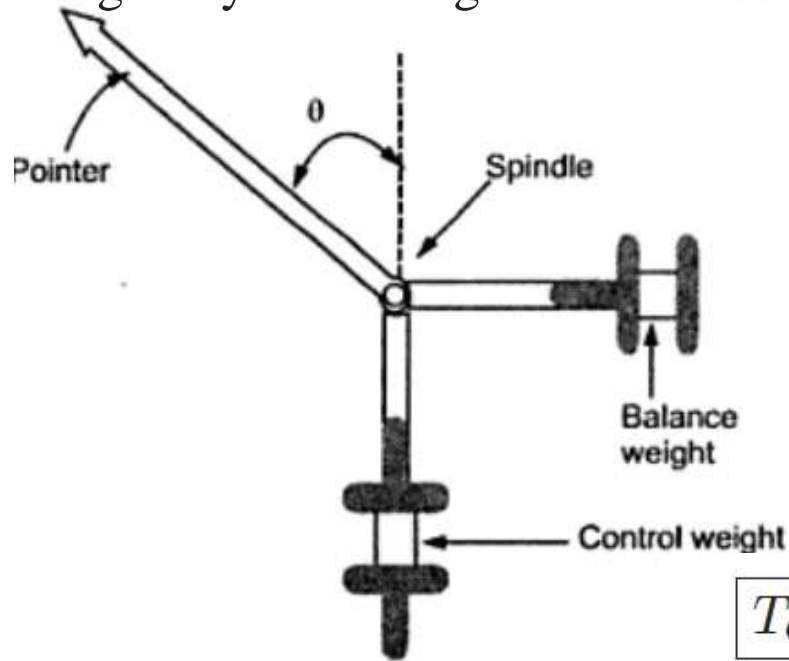

Gravity Control

$$T_C = W \sin \theta \times l$$

$$= K \sin \theta$$

$$\text{Here, } K = Wl$$

$$= \text{Gravity Constant}$$

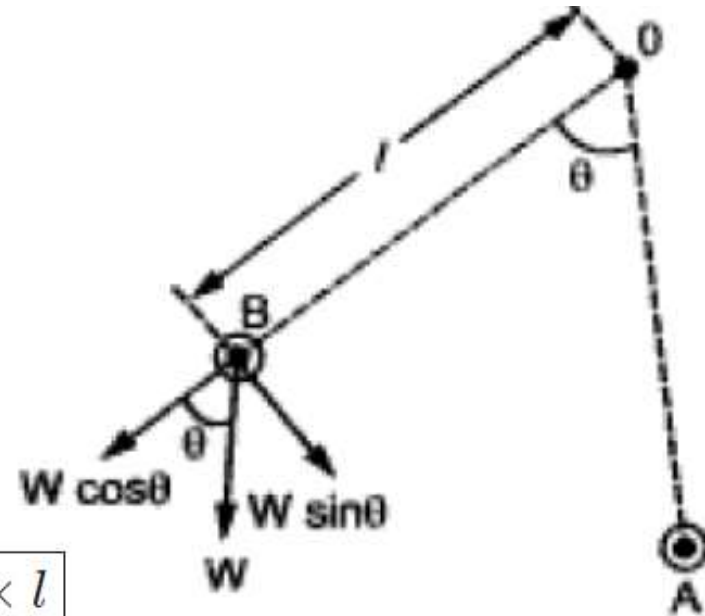

Spring control

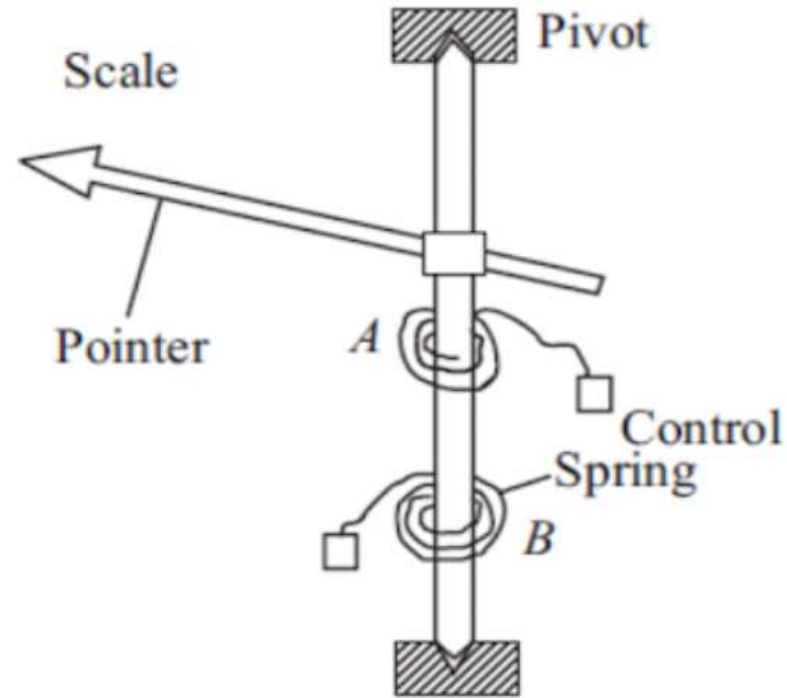

The controlling torque produced by the spiral spring is given by,

$$T_c = \frac{E b t^3}{12 L} \theta$$

E = Young's modulus of spring material in N/m^2

t = thickness in meters

b = depth in meters

L = length in meters

$$K_s = \text{Spring constant} = \frac{E b t^3}{12 L}$$

$$\therefore T_c \propto \theta$$

Comparison between Spring Control and Gravity Control

Mechanism

Sr. No.	Gravity Control	Spring Control
1.	Adjustable small weight is used which produces the controlling torque.	Two hairsprings are used which exert controlling torque.
2.	Controlling torque can be varied.	Controlling torque is fixed.
3.	The performance is not temperature dependent.	The performance is temperature dependent.
4.	The scale is non-uniform.	The scale is uniform.

5.	The controlling torque is proportional to $\sin \theta$	The controlling torque is proportional to θ
6.	The reading can not be taken accurately.	The readings can be taken very accurately.
7.	The system must be used in a vertical position only.	The system need not be necessarily in a vertical position.
8.	Proper leveling is required as gravity control.	The leveling is not required.
9.	simple, cheap but delicate.	Simple, rigid but costlier compared to gravity control.
10.	rarely used for indicating and portable instruments.	Very popular and used in most instruments.

Air friction damping

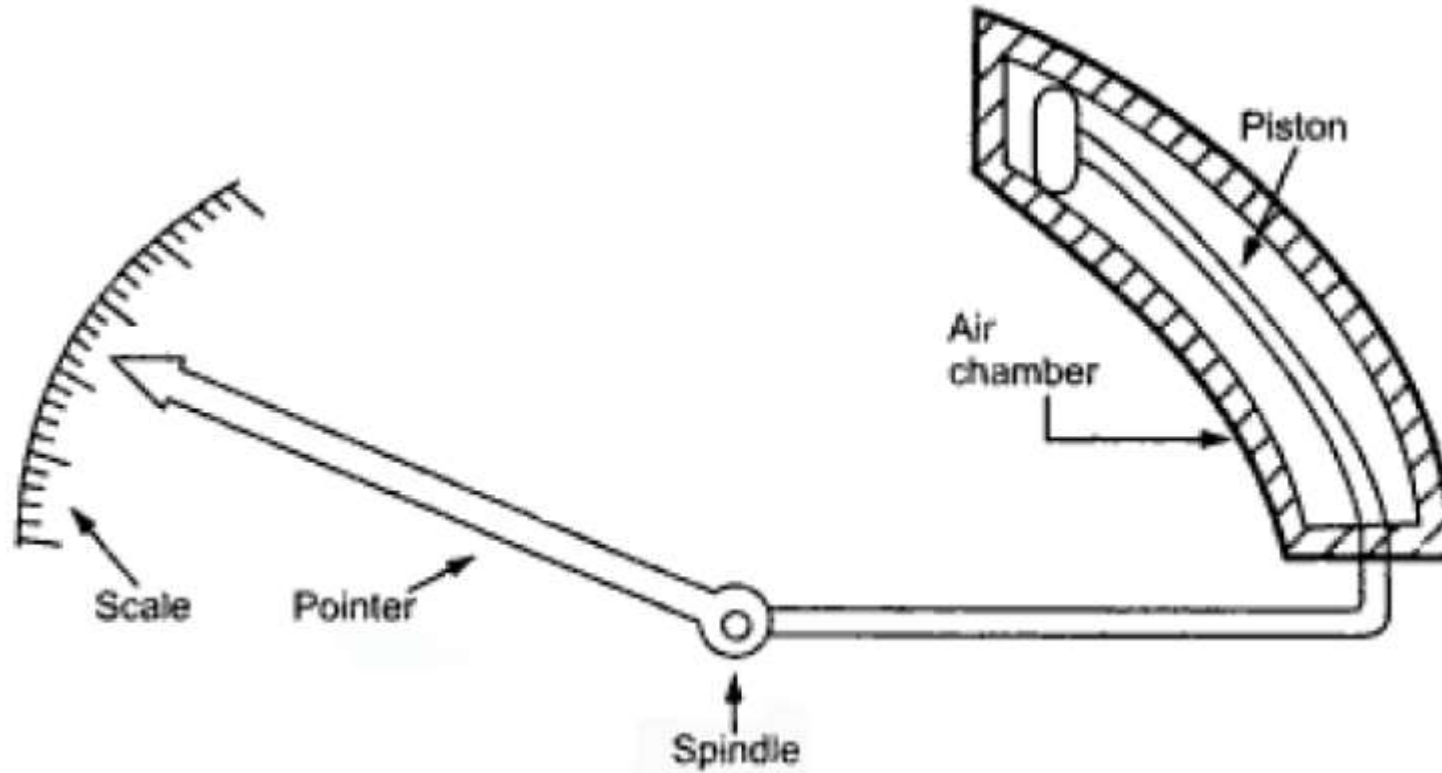

Air friction damping

Fluid friction damping

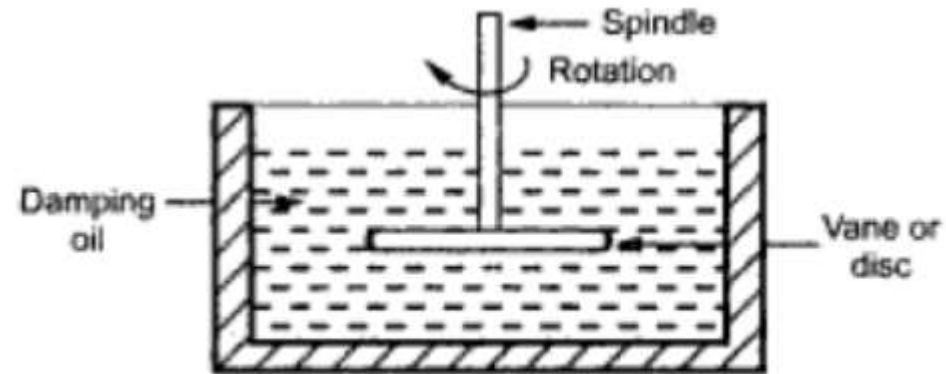

Fluid friction damping

Advantages of the Fluid Friction damping Method:

1. Due to the more viscosity of the fluid, more damping is provided.
2. The oil can also be used for insulation purposes.

Disadvantages of the Fluid Friction damping Method:

1. This can be only used for instruments that are in a vertical position.
2. Due to oil leakage, the instruments can not be kept clean.

Eddy current damping

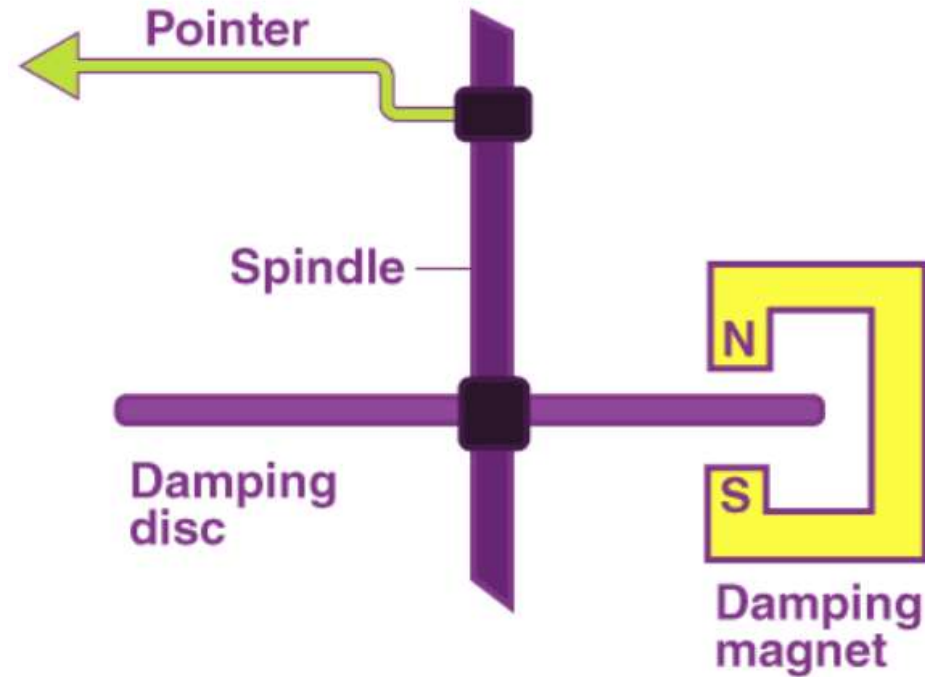

Advantages :

- It is the most efficient form of damping compared to other methods.
- It is especially used for moving coil and induction-type instruments.
- It can be used in portable instruments as well.

Disadvantages :

- It can't be used for moving iron or dynamo-type instruments.

Analog Ammeters

- Ammeters are connected in series in the circuit whose current is to be measured. The power loss in an ammeter is I^2R_a . Therefore ammeters should have a low electrical resistance so that they cause a small voltage drop and consequently absorb small power.

Analog Voltmeters

- Voltmeters are connected in parallel in the circuit whose voltage is to be measured. The power loss in a voltmeter is V^2/R_V . Therefore, voltmeters should have a high electrical resistance so that they cause a small voltage drop and consequently absorb small power.

Types of Instruments

- Permanent magnet moving coil (PMMC).
- Moving Iron
- Electro-dynamometer type.
- Hot wire type.
- Thermocouple type.
- Induction type.
- Electrostatic type.
- Rectifier type.

Permanent magnet moving coil

This permanent magnet moving coil meter movement is the basic movement in most analog (meter with a pointer indicator hand) measuring instruments. It is commonly called d'Arsonval movement because it was first employed by the Frenchman d'Arsonval in making electrical measurements.

PMMC is the most [accurate type for dc measurements](#). This type of meter movement is a current measuring device which is used in the ammeter, voltmeter, and ohmmeter. Basically, both the ammeter and the voltmeter are current measuring instruments, the principal difference being the method in which they are connected in a circuit.

- A permanent-magnet moving-coil movement is based upon a fixed permanent magnet and a coil of wire which can move.
- When the switch is closed, causing current through the coil, the coil will have a magnetic field which will react to the magnetic field of the permanent magnet.
- The bottom portion of the coil in figure will be the north pole of this electromagnet. Since opposite poles attract, the coil will move to the position as shown

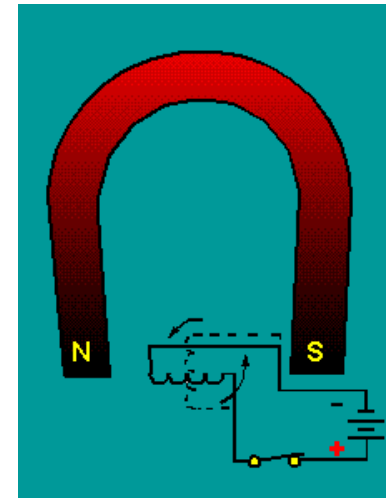
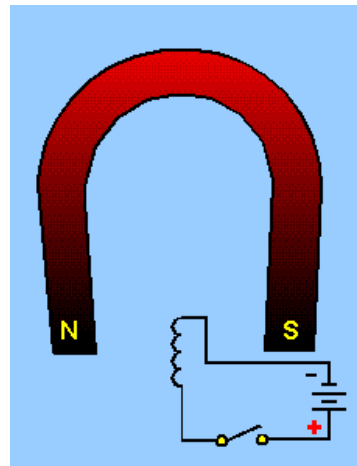

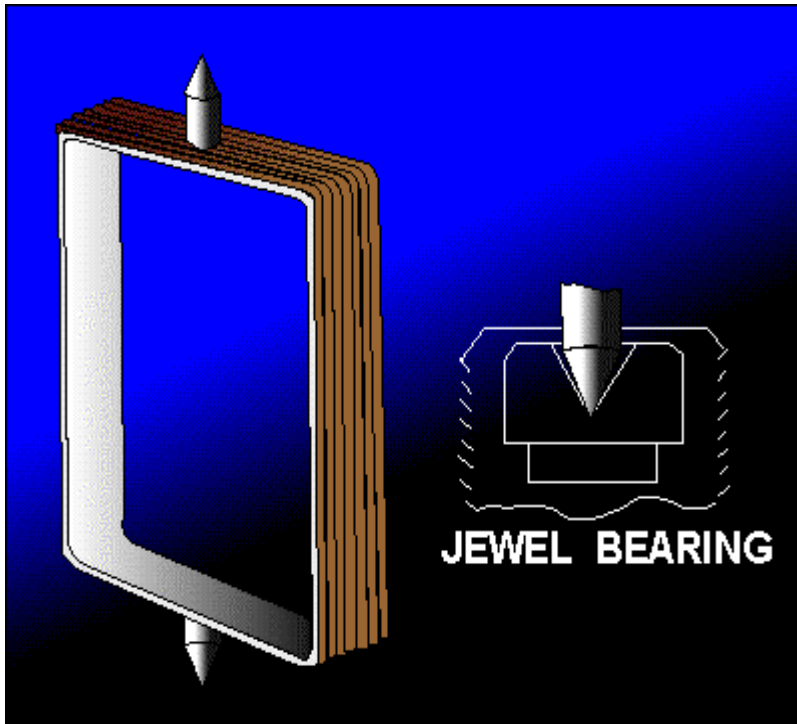

A basic coil arrangement

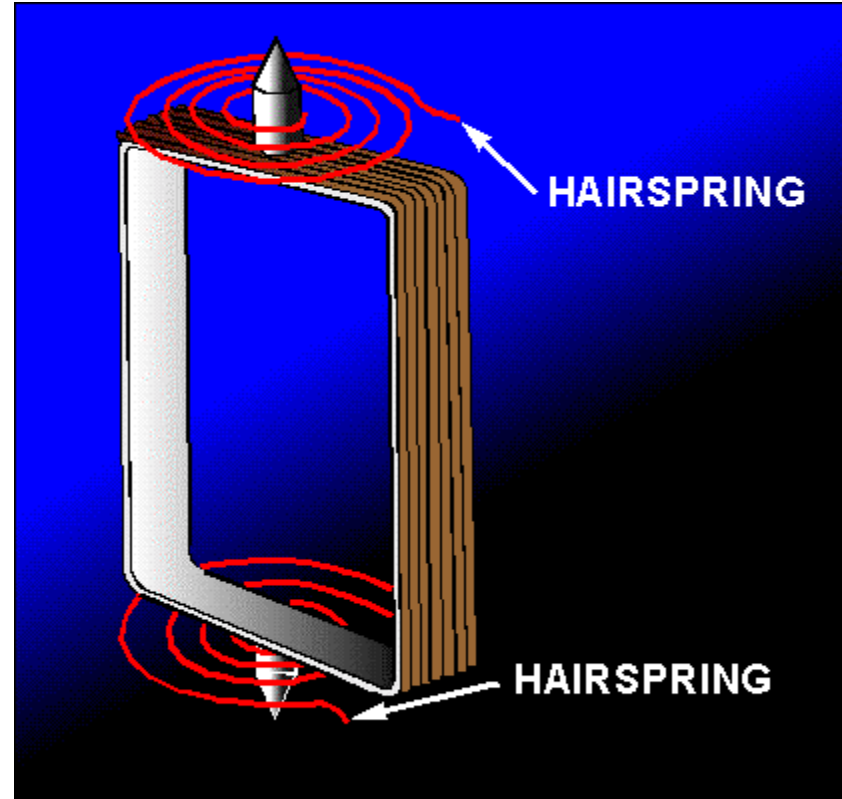

Coil and hairsprings

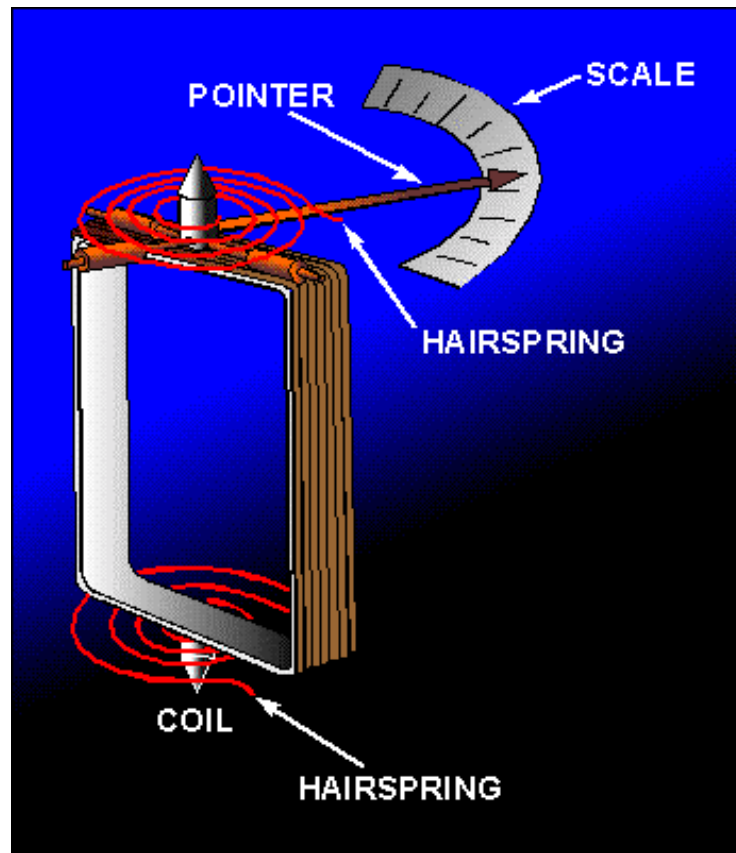

A complete coil.

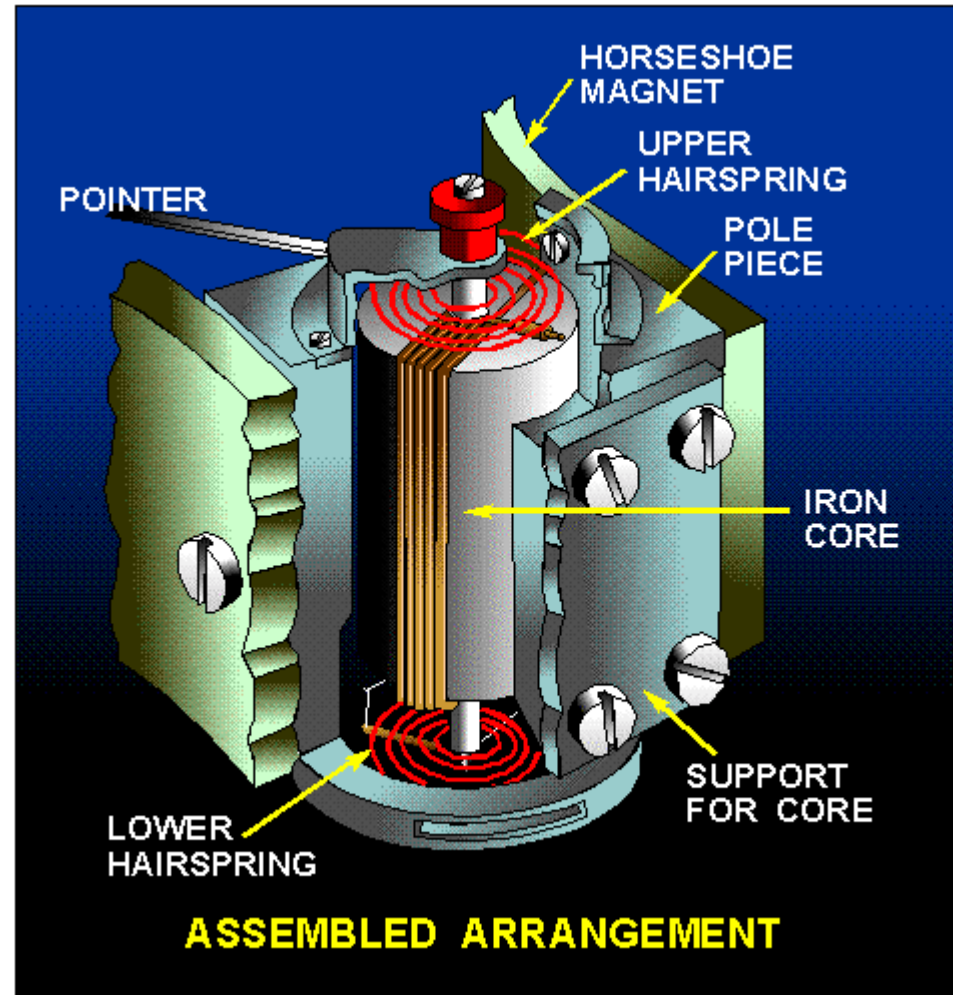

Assembled meter movement

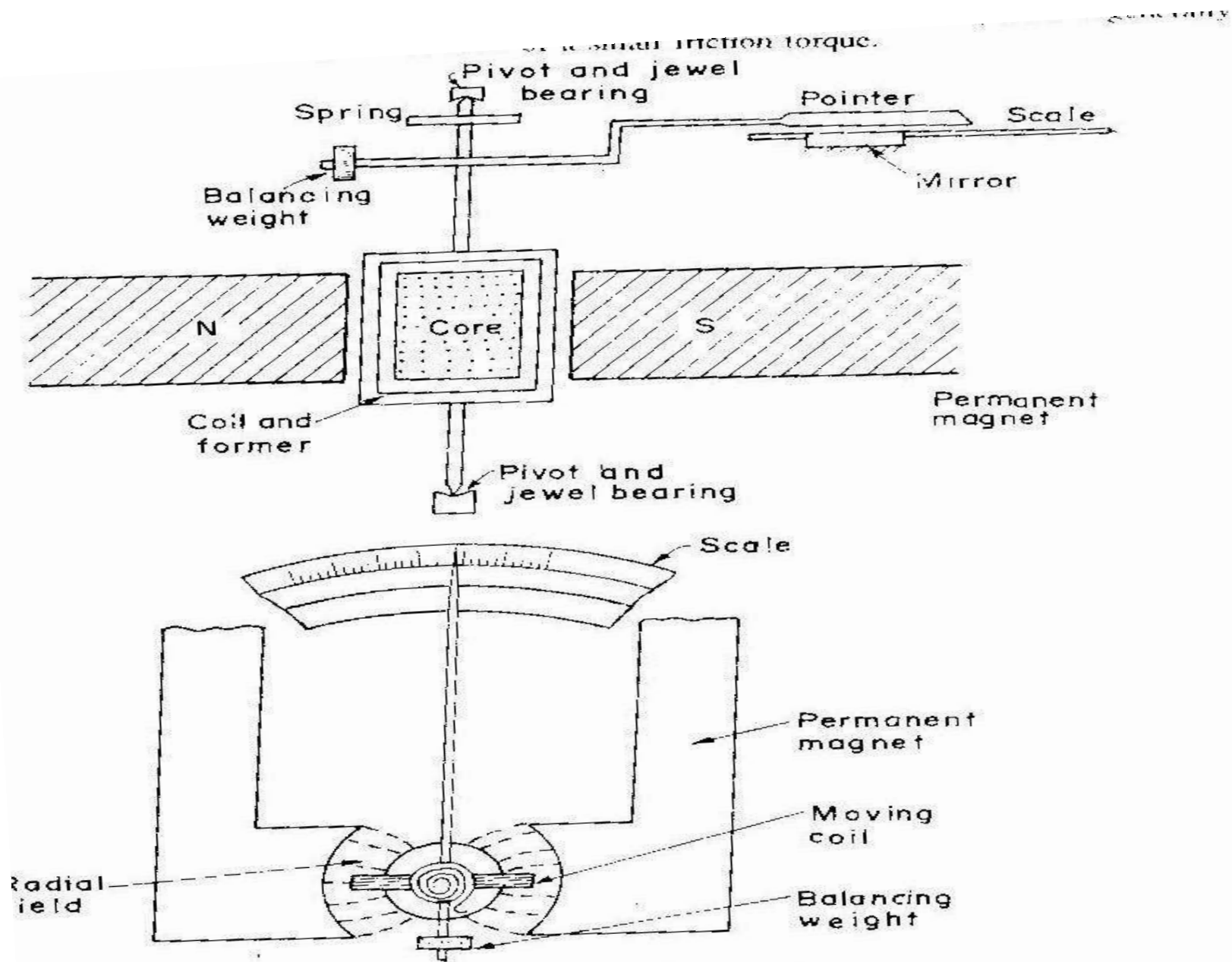
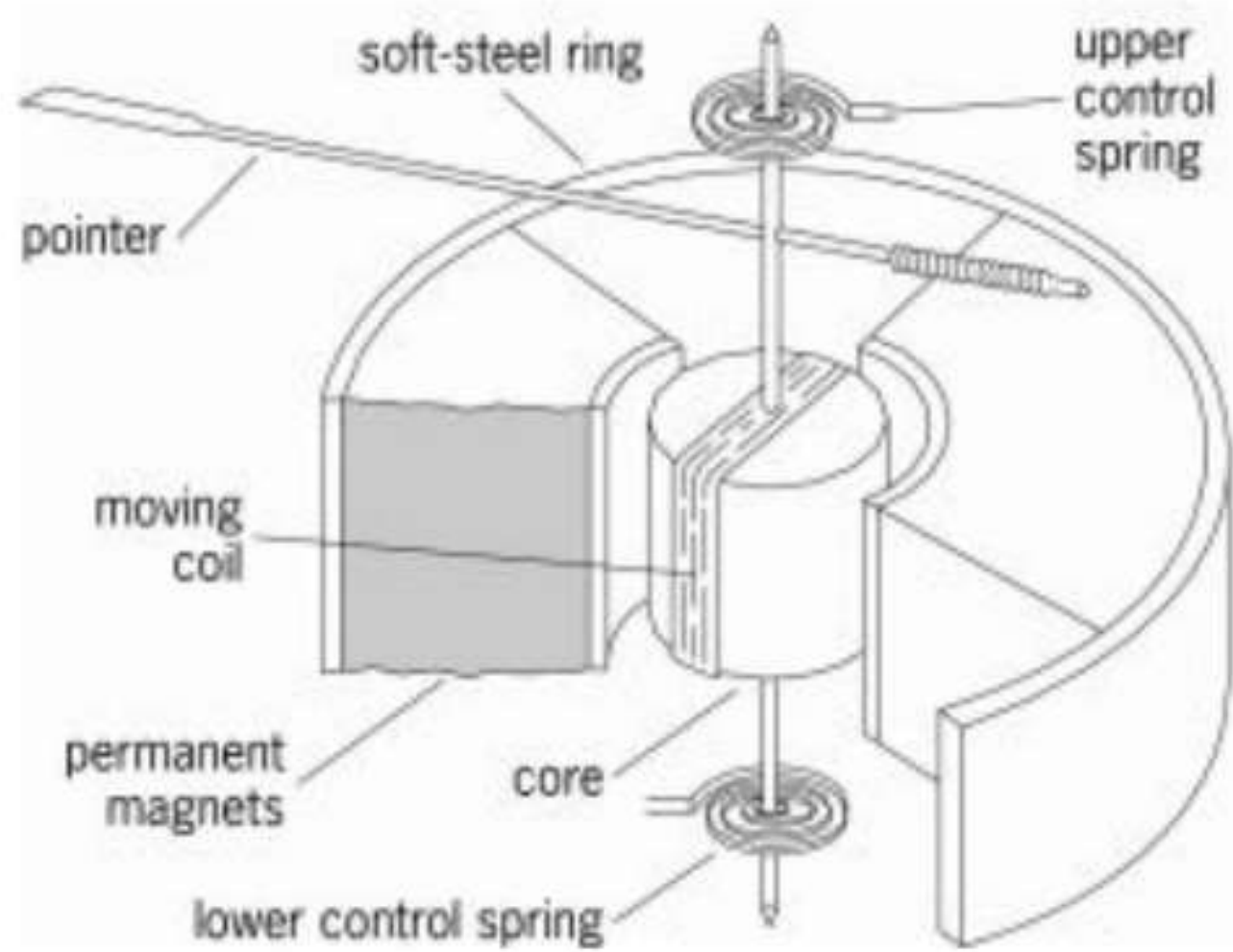

Fig. 9.1. Permanent magnet moving coil instrument.



- **Construction & working of PMMC Instruments**
- **Moving coil** is wound with many turns of enameled or silk covered copper wire. Coil is mounted on a rectangular aluminum former which is pivoted on jeweled bearings .
- Voltmeter coils are mount on metal frames to provide electromagnetic damping.
- Ammeter coils are wound on non-metallic former , because coils are shorted by ammeter shunt. Coil moves freely in the field of a permanent magnet.

- **Magnet Systems** : U-shaped PM is used. Alcomax and Alnico are used for making PM (High co-ercive). Flux densities used in PMMC vary from 0.1 wb/m^2 to 1 wb/m^2 . small instrument- small number of turns-reduction in volume. Similarly for large instruments.
- The iron core is spherical if coil is circular and is cylindrical if the coil is rectangular.
- Due to iron core , the deflecting torque increases, increasing the sensitivity of the instrument.
- **Control spring**: Controlling torque is provided by two phosphor bronze hair springs.

- **Eddy current damping:** Damping torque is provided by eddy current damping.
- **Pointer and scale arrangement:** The pointer is carried by the spindle, and it moves over a graduated scale.. The mirror is placed below the pointer to get accurate reading.

When a current carrying conductor is placed in the magnetic field produced by a permanent magnet, the coil experiences a force and moves the coil . As the coil is moving and the magnet is permanent, the instrument is called **Permanent Magnet Moving Coil Instrument(PMMC)**.

Torque equation

Deflecting Torque, $T_d = BINA$

Where

B = flux density in Wb/m² (Tesla)

I = current (A).

N = number of turns of the coils.

A = area (length X wide), (m²).

Controlling torque $T_c = K\theta$

At steady state position $T_d = T_c$

$$I \propto \theta$$

As the deflection is proportional to the current passing through the meter, we get a uniform (linear) scale for the instrument.

- As the direction of the current to the coil changes, the direction of deflection of the pointer also changes. Hence such instruments are well suited for the d.c. measurements.
- In micro and milli ammeters upto 20 mA, the entire current to be measured is passed through the coil. The springs carry current to the coil. Thus, the current carrying capacity of the springs, limits current which can safely be carried.
- For higher currents, the moving coil is shunted by sufficient resistance.
- While the voltmeters having high ranges use a moving coil together with sufficient series resistance, to limit the instrument current.

- Advantages of PMMC:

- It has uniform scale.
- With a powerful magnet, its torque to weight ratio is very high.
- Sensitivity is high.
- Consumes low power, of the order of 25W to 250 μ W.
- High accuracy.
- Instrument is free from hysteresis error.
- Extension of instrument range is possible.
- Not affected by external magnetic fields called stray magnetic fields.

Disadvantages:

1. Suitable for d.c. measurements only.
2. Ageing of permanent magnet and control springs introduces the errors.
3. Cost is high due to delicate construction and accurate machining.
4. Friction due to jewel-pivot suspension.

- **Errors in PMMC instrument:**

- Weakening of PM due to ageing at temperature effects.
 - Weakening of magnets are avoided by heating and vibration treatment.
This results in strengthening of magnets.
- Weakening of springs due to ageing and temperature effects.
 - The weakening of magnet cause less deflection while weakening of the control springs cause large deflection, for a particular value of current.

- Change of resistance of the moving due to temperature effect .
 - Error due to large change in the resistance of copper of the moving coil as compared to manganin shunt. This is because copper has a much high resistance temperature co-efficient as compared to manganin. To reduce, swamping resistor made up of manganin is connected in series with MC, so that copper coil forms only a small fraction of total resistance comprising the coil and additional swamping resistance.

Moving Iron Instruments

- The instrument in which the moving iron is used for measuring the flow of current or voltage is known as the moving iron instrument. It works on the principle that the iron piece near the magnet attracts towards it. The force of attraction depends on the strength of the magnet field. The magnetic field induces by the electromagnet whose strength depends on the magnitude of the current passes through it.

Construction of Moving Iron Instrument

- The plate or vane of soft iron is used as the moving element of the instrument. The vane is so placed that it can freely move in the magnetic field of the stationary coil. The conductor makes the stationary coil, and it is excited by the voltage or current whose magnitude is used to be measured.
- The moving iron instrument uses the stationary coil as an electromagnet. The electromagnet is the temporary magnet whose magnetic field strength increases or decreases with the magnitude of the current passes through it.

Working of the Moving Iron Instrument

- The moving iron instruments use the stationary coil of copper or aluminium wire which acts as an electromagnet when an electric current passes through it. The strength of the magnetic field induced by the electromagnet is directly proportional to the current passes through it.
- The plates or vane of the iron pass through the coil increases the inductance of the stationary coil (the inductance is the property of the conductor which increases their electromotive force when the varying current passes through it).

- The electromagnet attracts the iron vane. The vane passes through the coil tries to occupy the minimum reluctance path (the reluctance is the property of the magnet which opposes the flow of electric current).
- The vane passes through the coil experience a force of repulsion caused by the electromagnet. The repulsion force increases the strength of the coil inductance.
- This happens because the inductance and reluctances are inversely proportional to each other.

Classification of the Moving Iron Instruments

- The attraction and the repulsion are the types of the moving iron instruments. Their detail explanation is shown below.
- **1. Attraction Type** – The instrument in which the iron plate attracts from the weaker field towards the stronger field such type of instrument is known as the attraction type instrument.
- **Construction of Attraction Type Instrument** – The stationary coil of the attraction type instrument is flat and has a narrow opening. The moving element is the flat disc of the iron core. The current flow through the stationary coil produced the magnetic field which attracts the iron coil.

- The iron vane deflects from the low magnetic field to the high magnetic field, and the strength of the deflection is directly proportional to the magnitude of the current flow through it. In short, we can say that the iron coil attracts towards in.
- The attraction type instruments use spring, which provided the controlling torque. The deflection of the coil is reduced by the aluminium piston which is attached to the moving coil.

Moving Iron attraction Type Instrument

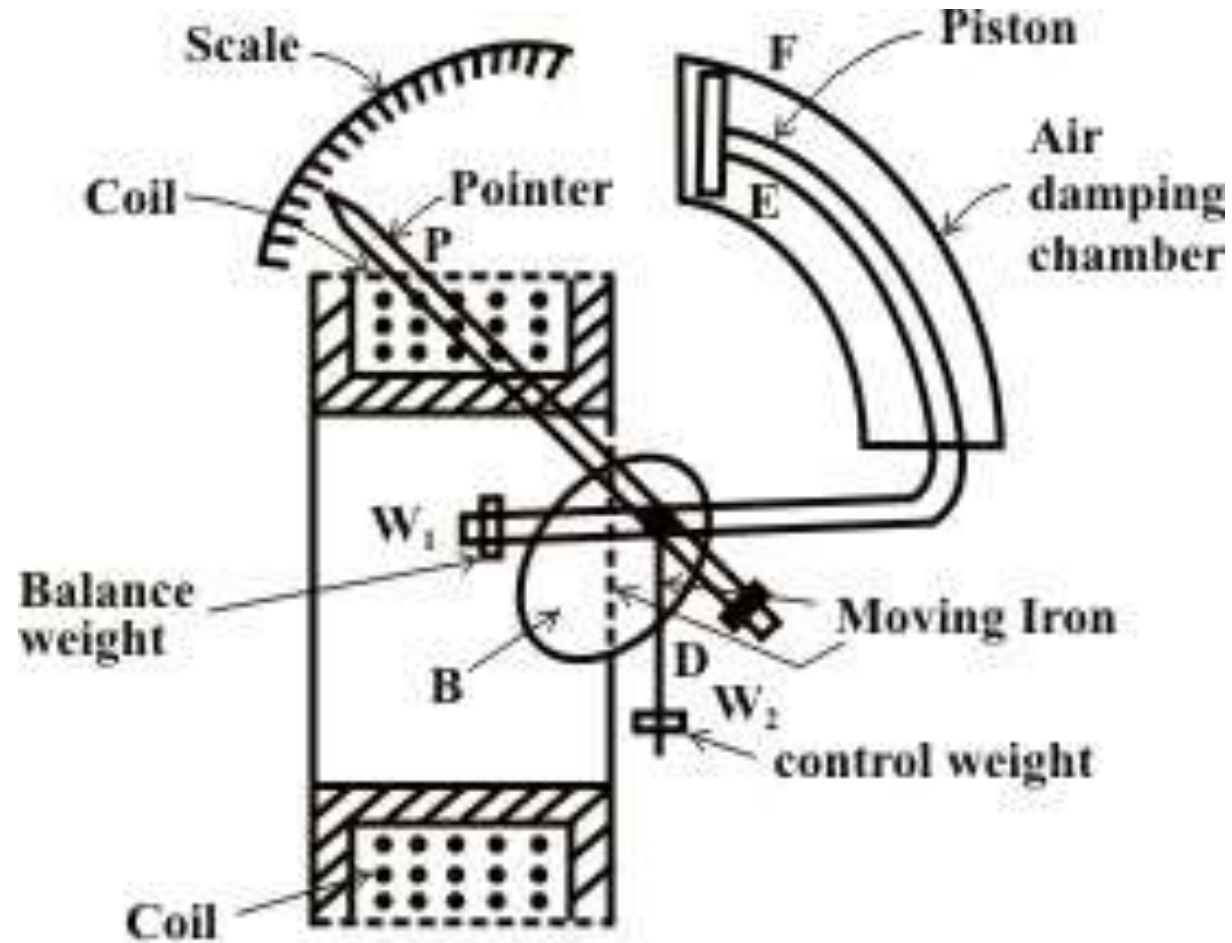
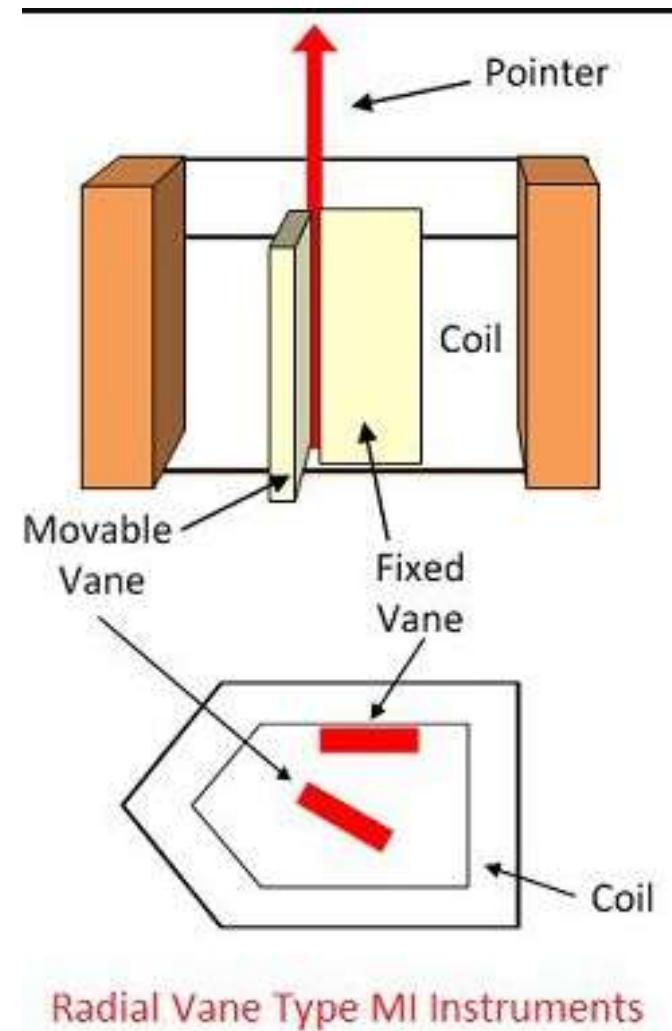

Fig. 42.8: Attraction type

2. Repulsion Type Instruments – The repulsion type instrument has two vanes or iron plates. One is fixed, and the other one is movable. The vanes become magnetised when the current passes through the stationary coil and the force of repulsion occur between them. Because of a repulsive force, the moving coil starts moving away from the fixed vane. The spring provides the controlling torque. The air friction induces the damping torque, which opposes the movement of the coil. The repulsion type instrument is a non-polarized instrument, i.e., free from the direction of current passes through it. Thus, it is used for both AC and DC.



Repulsion Type Moving Iron Instruments

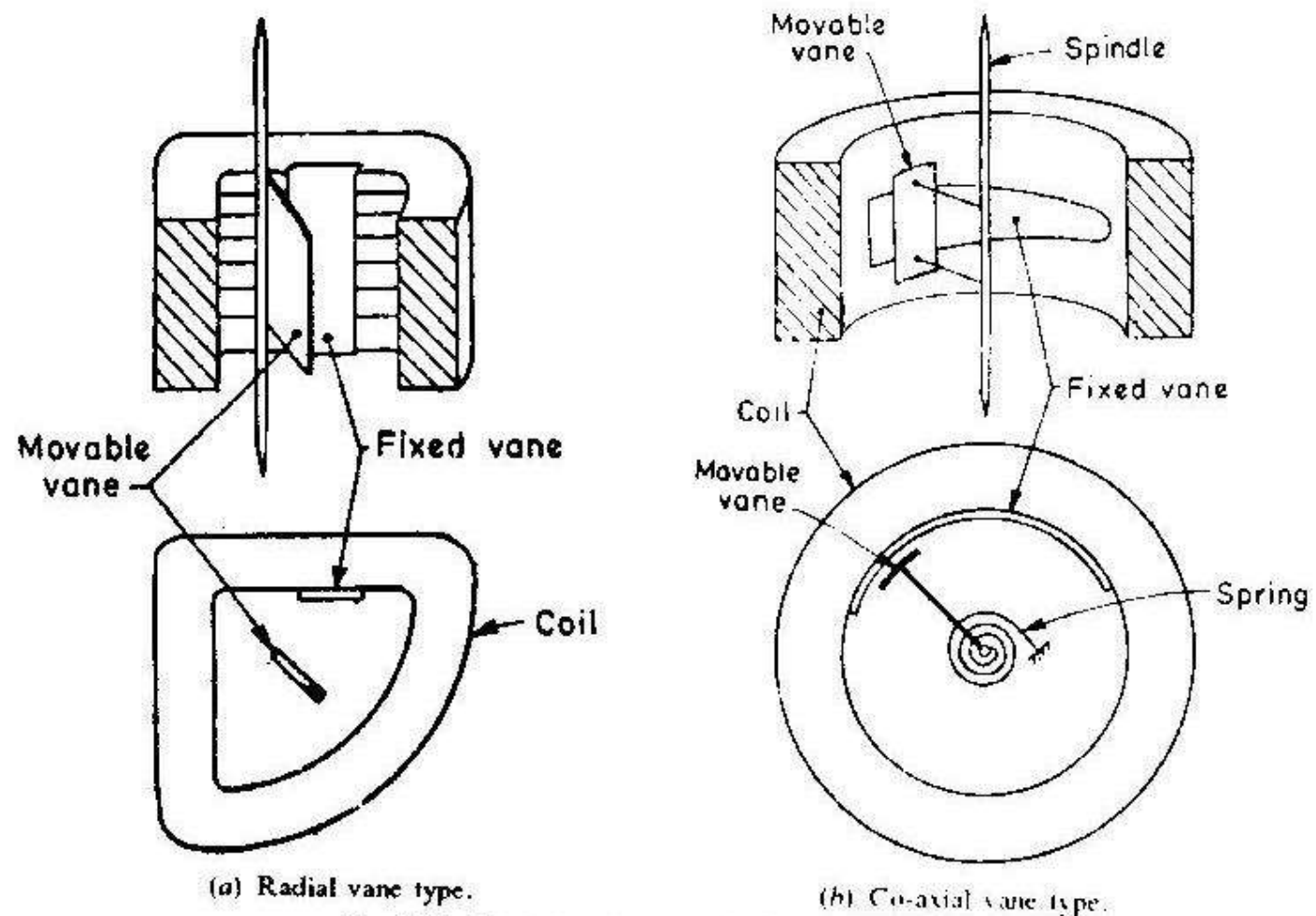

Fig. 9.25. Repulsion type moving iron instruments.

Torque equation of MI instrument.

Consider a small increment in current supplied to the coil of the instrument. due to this current let $d\theta$ be the deflection under the deflecting torque T_d . Due to such deflection, some mechanical work will be done.

$$\therefore \text{Mechanical Work} = T_d d\theta$$

There will be a change in the energy stored in the magnetic field due to the change in inductance. This is because the vane tries to occupy the position of minimum reluctance. The inductance is inversely proportional to the reluctance of the magnetic circuit of coil.

Let,

I = initial current

L = instrument inductance

θ = deflection

dI = increase in current

$d\theta$ = change in deflection

dL = change in inductance

In order to effect an increment dL in the current, there must be an increase in the applied voltage given by,

$$e = \frac{d(LI)}{dt}$$

$$= I \frac{dL}{dt} + L \frac{dI}{dt}$$

as both I and L are changing.

The electrical energy supplied is given by,

$$\begin{aligned} e i dt &= \left(l \frac{dL}{dt} + L \frac{dl}{dt} \right) i dt \\ &= l^2 dL + lL dl \end{aligned}$$

The stored energy increases from $\frac{1}{2} L l^2$ to $\frac{1}{2} (L + dL) (l + dl)^2$

Hence the change in stored energy is given by,

$$= \frac{1}{2} (L + dL) (l + dl)^2 - \frac{1}{2} L l^2$$

Neglecting higher order terms, this becomes, $lL dl + \frac{1}{2} l^2 dL$

The energy supplied is nothing but increase in stored energy plus the energy required for mechanical work done.

$$\therefore l^2 dL + lL dl = lL dl + \frac{1}{2} l^2 dL + T_d \cdot d\theta$$

$$\therefore T_d \cdot d\theta = \frac{1}{2} l^2 dL$$

$$\therefore T_d = \frac{1}{2} l^2 \frac{dL}{d\theta}$$

While the controlling torque is given by,

$$T_c = K \theta$$

where

K = spring constant

$$\therefore K \theta = \frac{1}{2} I^2 \frac{dL}{d\theta}$$

$$\therefore \theta = \frac{1}{2} \frac{I^2}{K} \frac{dL}{d\theta}$$

under equilibrium

Thus the deflection is proportional to the square of the current through the coil. And the instrument gives square law response.

Advantages of the MI Instruments

- **Universal use** – The MI instrument is independent of the direction of current and hence used for both AC and DC.
- **Less Friction Error** – The friction error is very less in the moving iron instrument because their torque weight ratio is high. The torque weight ratio is high because their current carrying part is stationary and the moving parts are lighter in weight.
- **Cheapness** – The MI instruments require a smaller number of turns as compared to PMMC instrument. Thus, it is cheaper.
- **Robustness** – The instrument is robust because of their simple construction. And also, because their current carrying part is stationary.

Disadvantages of Moving Iron Instruments.

- **Accuracy** – The scale of the moving iron instruments is not uniform, and hence the accurate result is not possible.
- **Errors** – Some serious error occurs in the instruments because of the hysteresis frequency and stray magnetic field.
- **Waveform Error** – In MI instrument the deflection torque is not directly proportional to the square of the current. Because of which the waveforms error occurs in the instrument.
- **Difference between AC and DC calibration** – The calibration of the AC and DC are differed because of the effect of the inductance of meter and the eddy current which is used on AC. The AC is calibrated on the frequency at which they use.

Errors in moving Iron instrument

Hysteresis Error

This error occurs as the value of flux density is different for the same current when ascending and descending. The value of flux density is higher for descending values of current and, therefore, the instrument tends to read higher for descending values of current (and voltage) than for ascending values.

This **error can be minimized** by making the iron parts small so that they demagnetize themselves quickly.

Temperature Error

The effect of temperature changes on moving iron instruments arises chiefly from the temperature coefficient of spring. The error may be 0.02 percent per °C. In voltmeters, errors are caused due to self-heating of coil and series resistance.

The temperature of the coil may increase by 10 to 20°C for a power consumption of 1 W. Therefore, the resistance increases (by about 4 to 8%, causing a decrease in current for a given voltage. This produces a decreased deflection. Therefore, the series resistance should be made of a material like Manganin which has a small temperature co-efficient.

3) Stray magnetic Field Error: The operating magnetic field in case of moving iron instruments is very low. Hence effect of external i.e. stray magnetic field can cause error. This effect depends on the direction of the stray magnetic field with respect to the operating field of the instrument.

4) Frequency Error: These are related to an ac operation of the instrument. The change in frequency affects the reactance of the working coil and also affects the magnitude of the eddy currents. This cause error in the instrument.

5) Eddy Current Error: When instrument is used for ac measurements the eddy currents are produced in the iron parts of the instrument. The eddy current affects the instrument current causing the change in the deflection torque. This produces the error in the meter reading. As eddy current are frequency dependent, frequency changes cause eddy current errors.

Extension of Range Of PMMC Instruments

Ammeter Shunts

When the PMMC instrument is used as an ammeter, its range can be extended with the help of a low-resistance shunt.

The moving-coil instrument has a coil wound with very fine wire. It can carry only a few mA safely to give full-scale deflection.

For measuring higher current, **low resistance is connected in parallel** to the instrument to bypass the major part of the current. The low resistance connected in parallel with the coil is called a **shunt**.

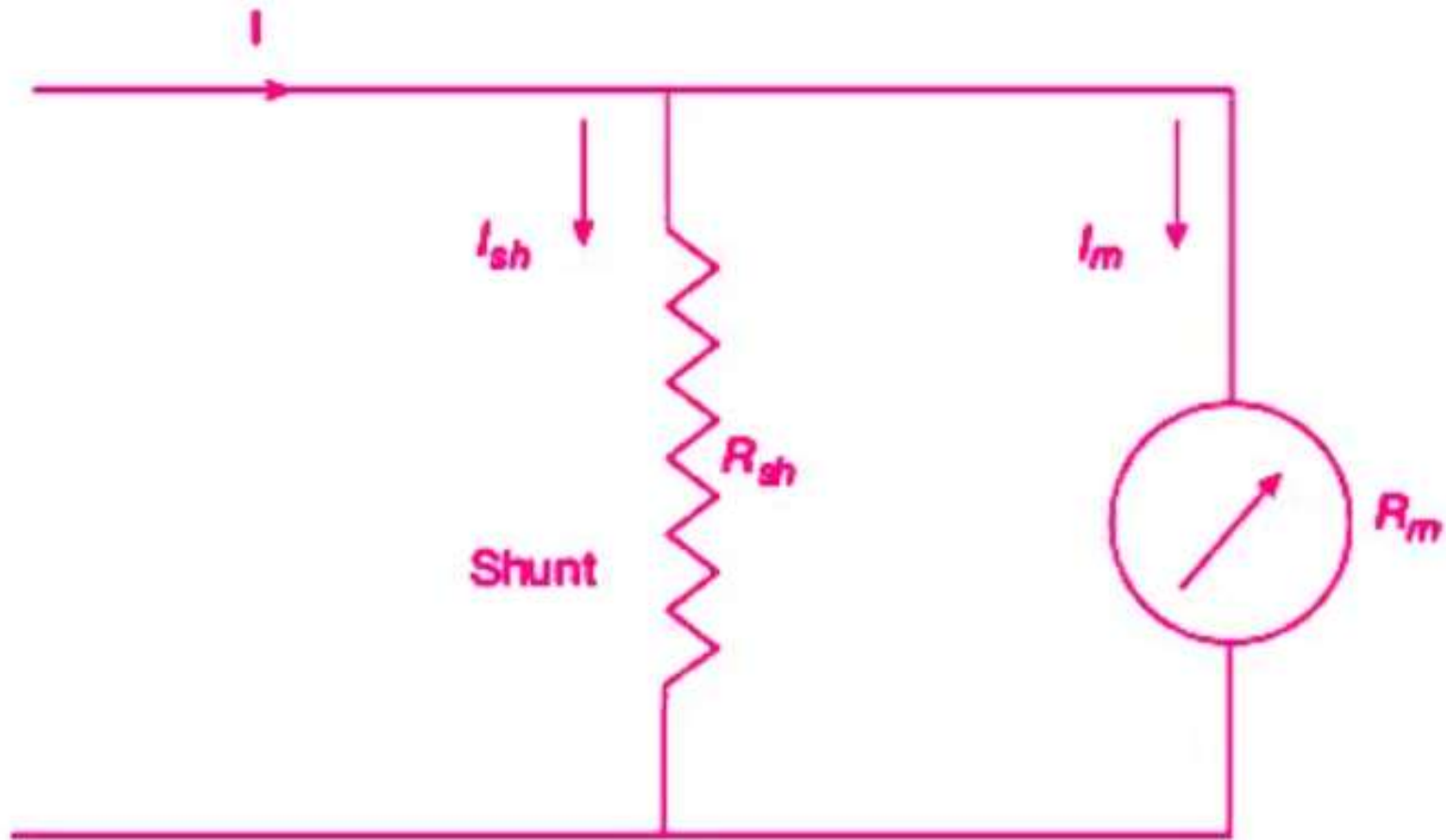

R_{sh} = shunt resistance (Ω)

R_m = coil resistance (Ω)

I_m = I_{fs} = full-scale deflection current (A)

I_{sh} = shunt current (A)

I = current to be measured (A)

The voltage drop across the shunt and the meter must be the same as they are connected in parallel.

$$I_{sh} R_{sh} = I_m R_m$$

$$I = I_{sh} + I_m$$

$$I_{sh} = I - I_m$$

From first equation,

$$R_{sh} = (I_m / I_{sh}) R_m$$

$$R_{sh} = (I_m / I - I_m) R_m$$

The ratio of the total current to the current in the meter is called the multiplying power of shunt. Multiplying power,

$$m = I/I_m = 1 + R_m/R_{sh}$$

$$\mathbf{R_{sh} = R_m / (m-1)}$$

Multirange Ammeters :

The range of an ammeter can be extended by using a shunt. Hence, by adding a number of shunts, it can be used as a multirange ammeter and such arrangement is shown below.

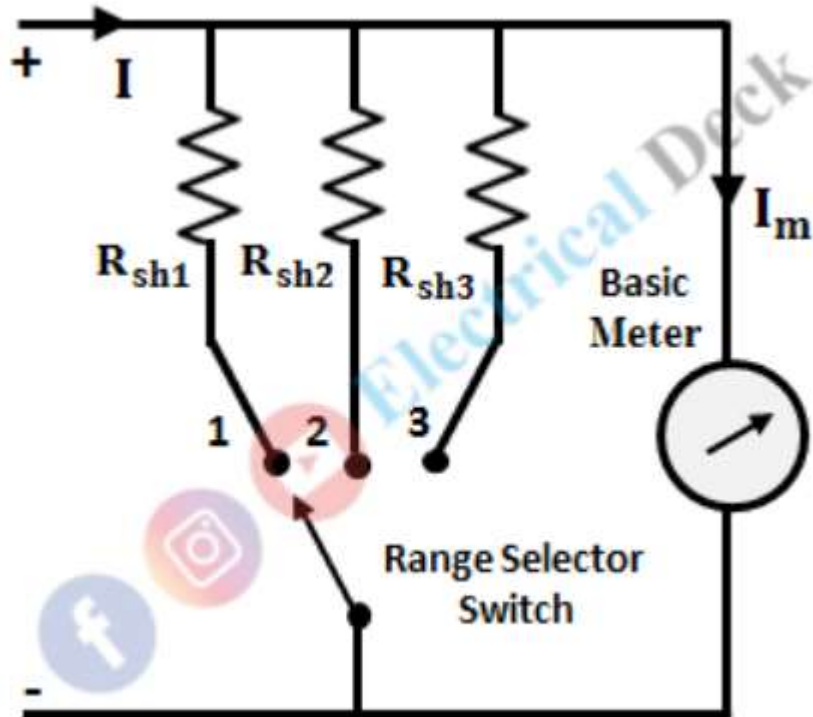

$$R_{sh1} = \frac{R_m}{m_1 - 1}, R_{sh2} = \frac{R_m}{m_2 - 1}$$
$$R_{sh3} = \frac{R_m}{m_3 - 1}$$

Voltmeter Multipliers

The range of PMMC instrument, when used as a voltmeter, can be increased by using a high resistance in series with it.

For measuring higher voltages, a high resistance is connected in series with the instrument to limit the current in the coil to a safe value. This value of current should never exceed the current required to produce full-scale deflection.

The high resistance connected in series with the instrument is called a **multiplier**. In the figure, R_{sc} is the multiplier.

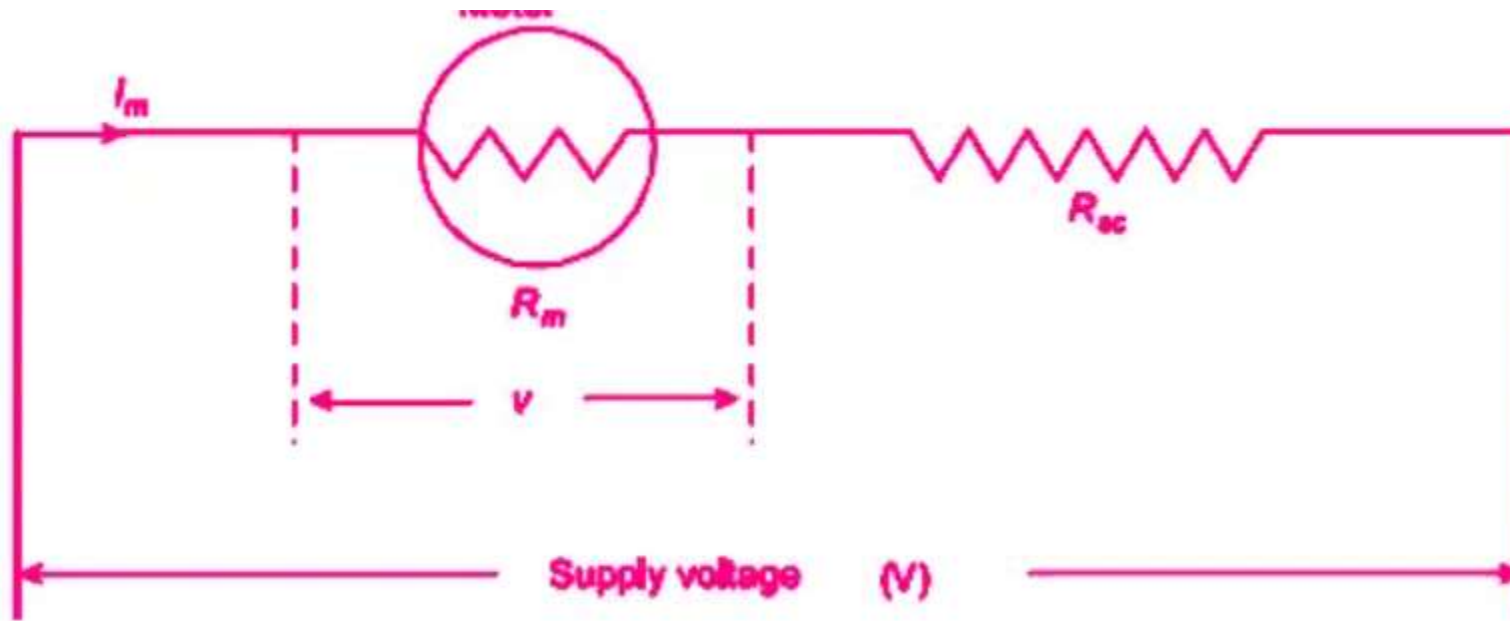

The value of multiplier required to extend the voltage range is calculated as under:

R_{sc} = multiplier resistance (Ω)

R_m = meter resistance (Ω)

$I_m = I_{fs}$ = full scale deflection current (A)

v = voltage across the meter for producing current I_m (V)

V = voltage to be measured (V)

$$v = I_m R_m$$

$$V = I_m (R_m + R_{sc})$$

Therefore,

$$R_{sc} = (V - I_m R_m) / I_m = V / I_m - R_m$$

Now multiplying factor for multiplier,

$$m = V/v = I_m (R_m + R_{sc}) / I_m R_m = 1 + R_{sc}/R_m$$

$$\text{Therefore, } R_{sc} = (m-1)R_m$$

Electrostatic Voltmeters

In the last article, we have seen about electrostatic instruments. An electrostatic instrument is basically a voltmeter that works on the principle of static electric field.

They are used for voltage measurement (especially for high voltages) but can also be used for measuring current and power with the additional arrangement.

The electrostatic voltmeters are of two types,

- Quadrant type electrostatic voltmeter (used up to 20kV)
- Attracted disc type electrostatic voltmeter (used up to 500kV)

Attracted Disc Type Electrostatic Voltmeter

An attracted disc type electrostatic instrument is basically known as a portable electrostatic instrument. This device contains two semicircular plates one being stationary and the other rotating. Both the plates are electrically insulated from each other.

The unknown voltage to be measured is applied across the plates, which results in the development of an electrostatic field between the plates. The electrostatic field developed is attractive in nature. The below shows the portable electrostatic instrument.

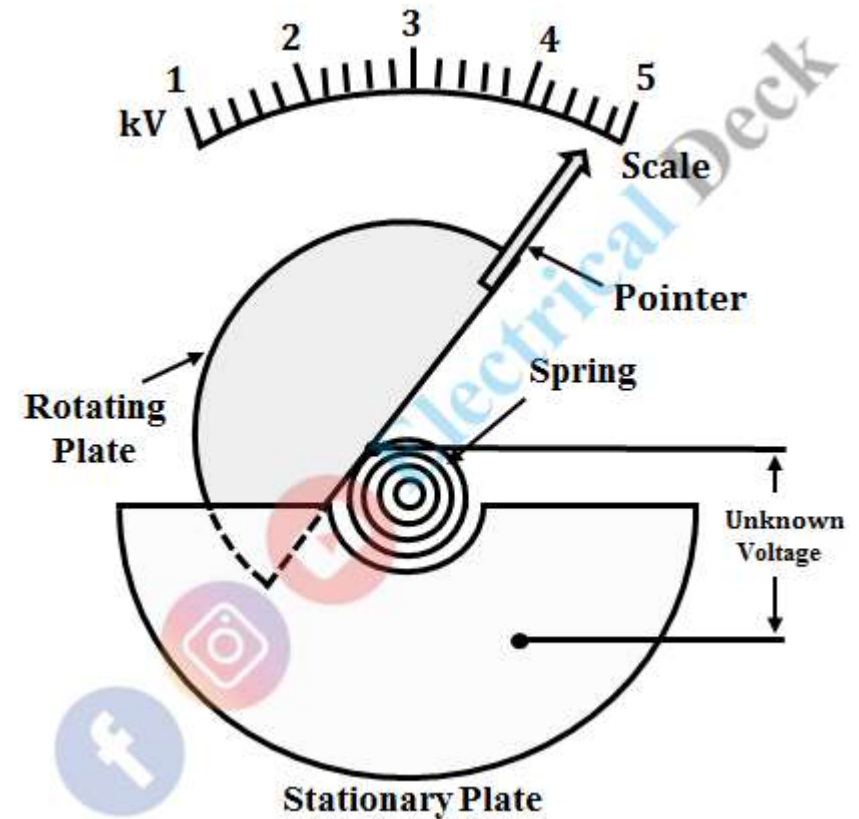

Kelvin's absolute electrometer is an attracted disc type electrostatic voltmeter.

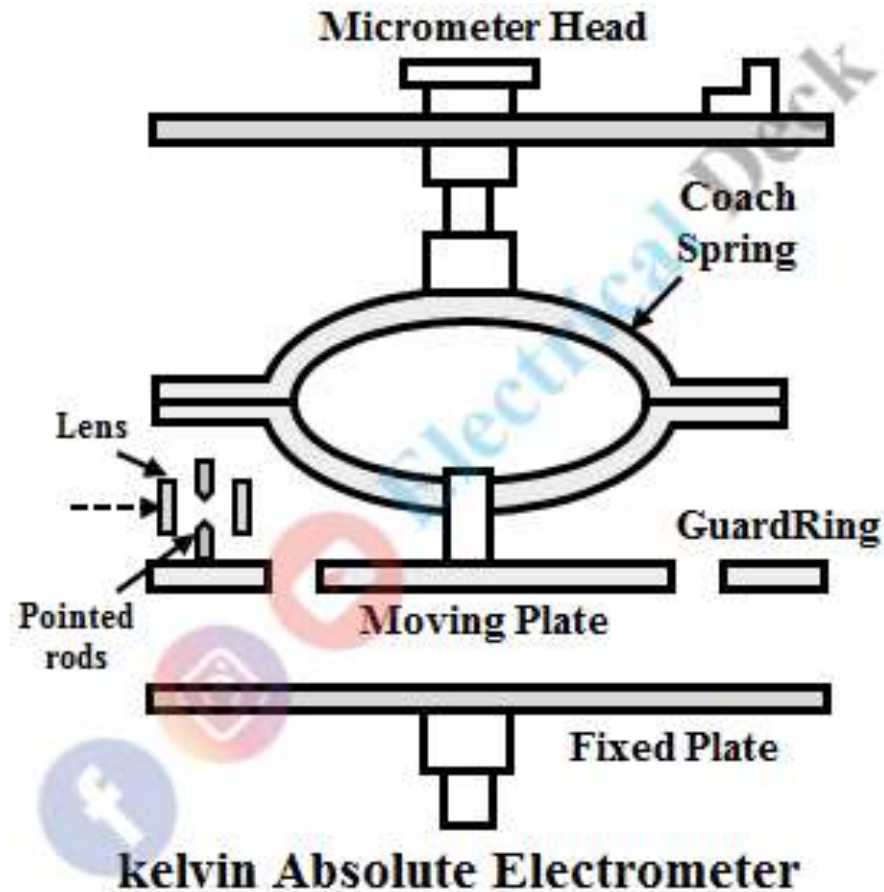

- A voltage that is to be measured is applied between the two plates.
- When a potential difference is applied between the plates then the moving plate will be attracted towards the fixed plate.
- But by rotating the micrometer head the moveable plate can be brought back to its original location.
- A micrometer which is calibrated in terms of force is used to measure the displacement of the moving plate.

Quadrant Type Electrostatic Voltmeter :

The quadrant electrometer consists of four metallic quadrants and a double sector shaped moving vane or needle as shown in the below figure.

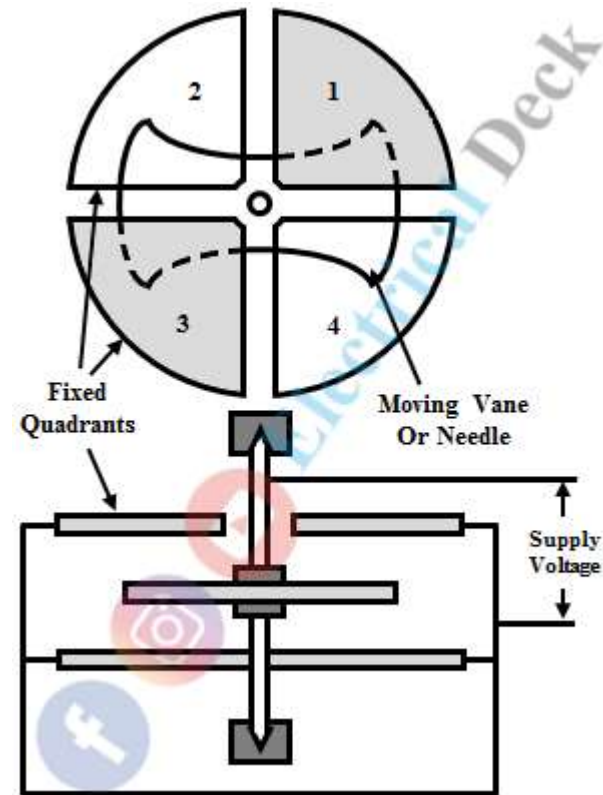

There are two types of connections in a quadrant electrometer. They are,

- Heterostatic connection, and
- Idiostatic connection.

Heterostatic Connection :

In this type of connection voltage to be measured is applied across the fixed quadrants. A high tension (HT) battery is used to charge the moving needle more positively than the fixed quadrants (i.e., voltage to be measured). The heterostatic connection is shown below.

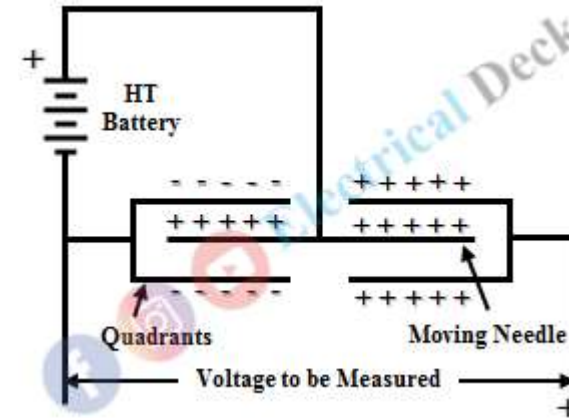

In this type of connection, there is no additional external voltage. The moving needle is connected to any pair of quadrants directly as shown below.

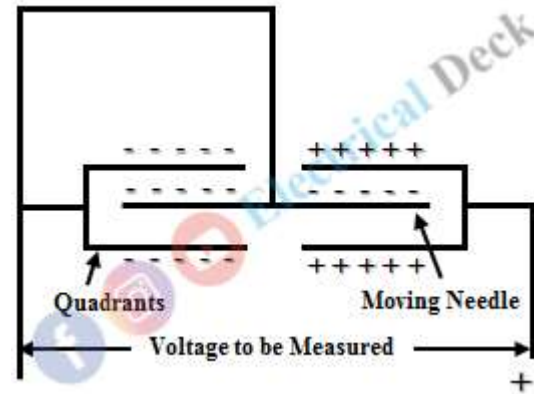

CONCLUSION

DC and AC Potentiometers

DC potentiometer

- A potentiometer is an instrument used for the measurement of unknown voltage by comparing it with a known voltage. The known voltage is supplied by a standard cell or battery.

Advantages:

- The accuracy depends on the known reference voltage and not on the deflection of pointer.
- It consumes no power when the circuit is unbalanced.
- It can also be used for the measurement of current.

Applications:

- It is mainly used for the calibration of ammeter and voltmeter

Basic slide wire potentiometer & standardization of potentiometer

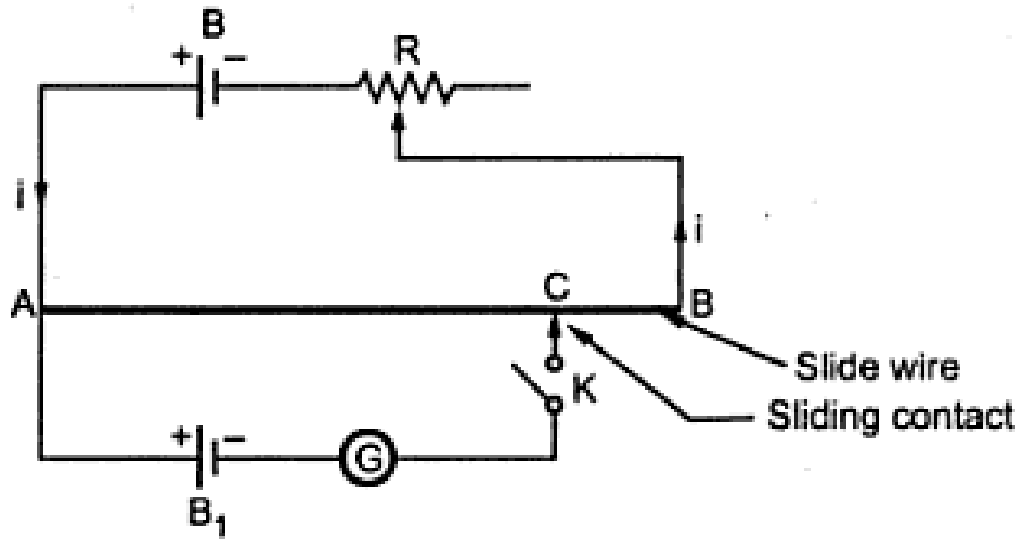

Basic slide wire potentiometer

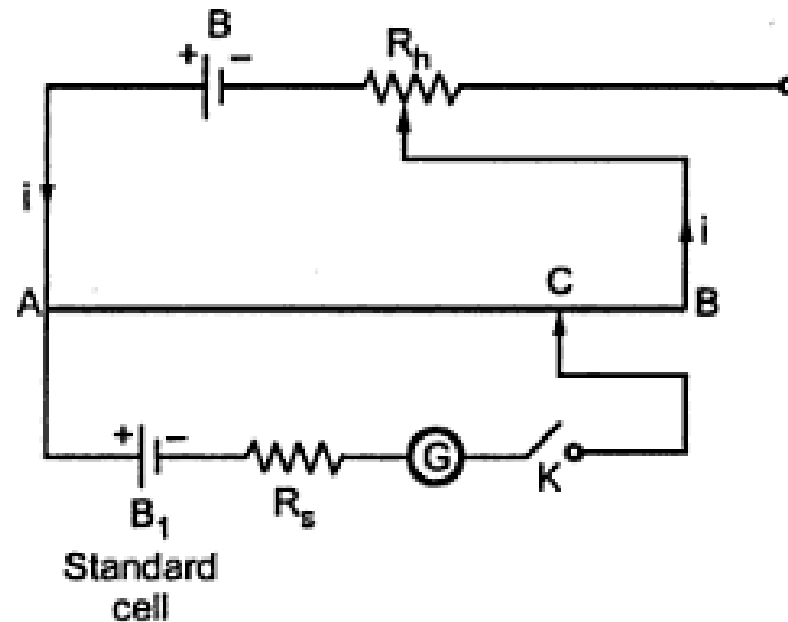

Practical set up for d.c. potentiometer standardisation

Laboratory type or Crompton potentiometer

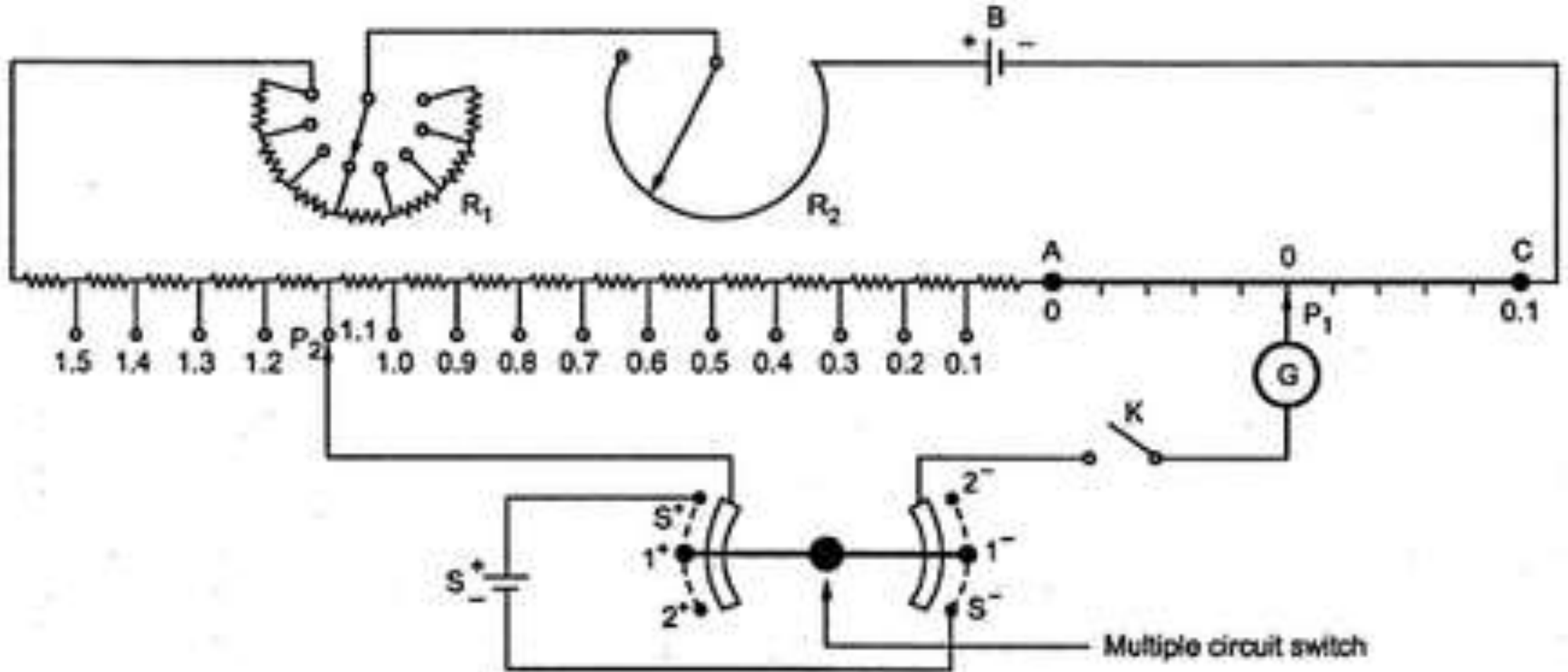

Crompton's D.C. potentiometer

Duo range potentiometer

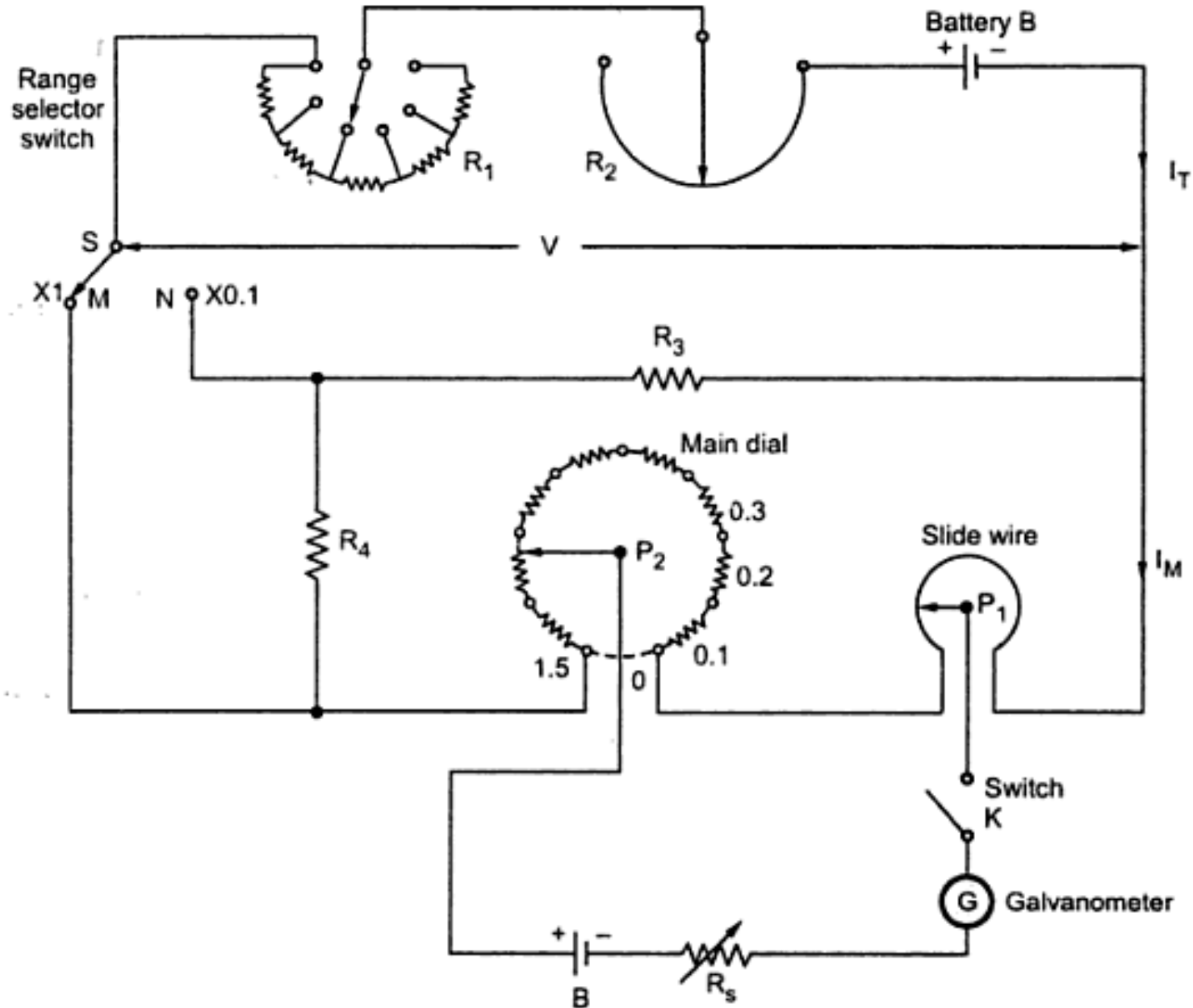

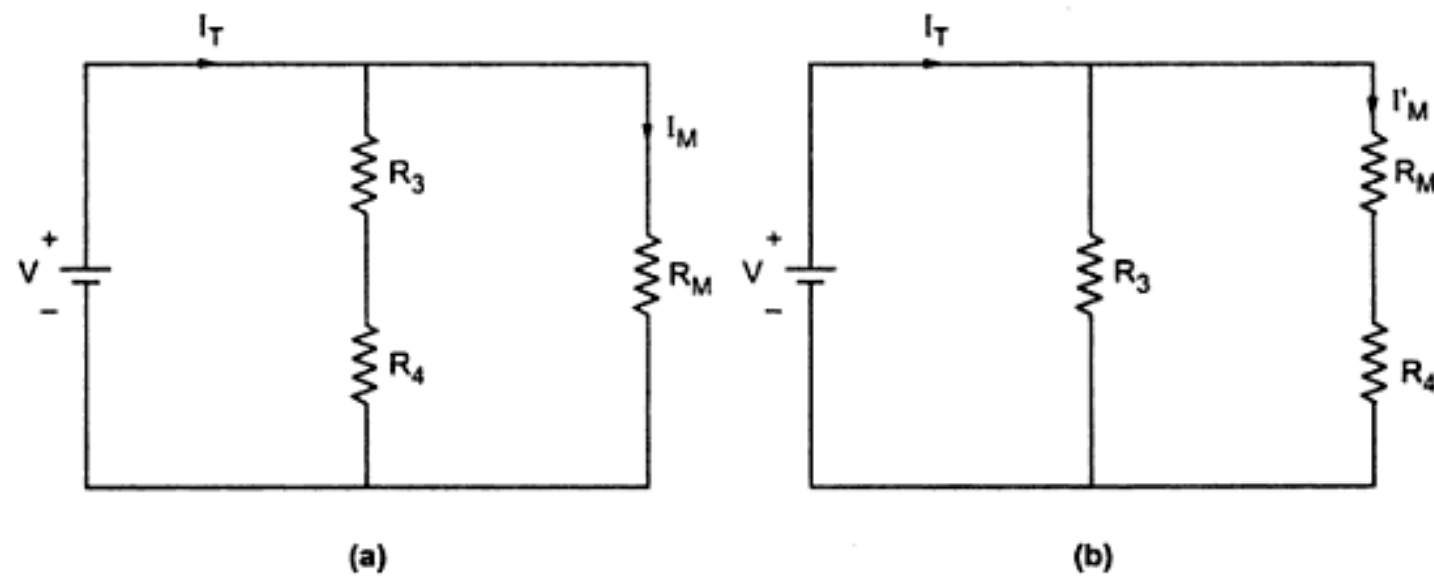

Simplified circuits of duo-range potentiometer for different range selections

In order to have the same current I_T for both ranges, the condition is,

$$(R_3 + R_4) \parallel R_M = R_3 \parallel (R_M + R_4)$$

$$\therefore \frac{(R_3 + R_4) R_M}{R_3 + R_4 + R_M} = \frac{R_3 (R_M + R_4)}{R_3 + R_4 + R_M}$$

$$\therefore R_3 R_M + R_4 R_M = R_3 R_M + R_3 R_4$$

$$R_M = R_3$$

∴ the second condition states that the current I'_M when switch S is at position N must be equal to $0.1 I_M$ where I_M is the current through R_M when switch S is at position M.

$$\therefore I'_M = 0.1 I_M$$

$$\therefore \frac{V}{R_M + R_4} = 0.1 \left[\frac{V}{R_M} \right]$$

$$\therefore R_M = 0.1 (R_M + R_4)$$

$$\therefore R_4 = 9 R_M = 9 R_3$$

Thus by properly designing values of R_3 and R_4 we can achieve high resolution in measurement using **duo-range** potentiometers.

Volt ratio box

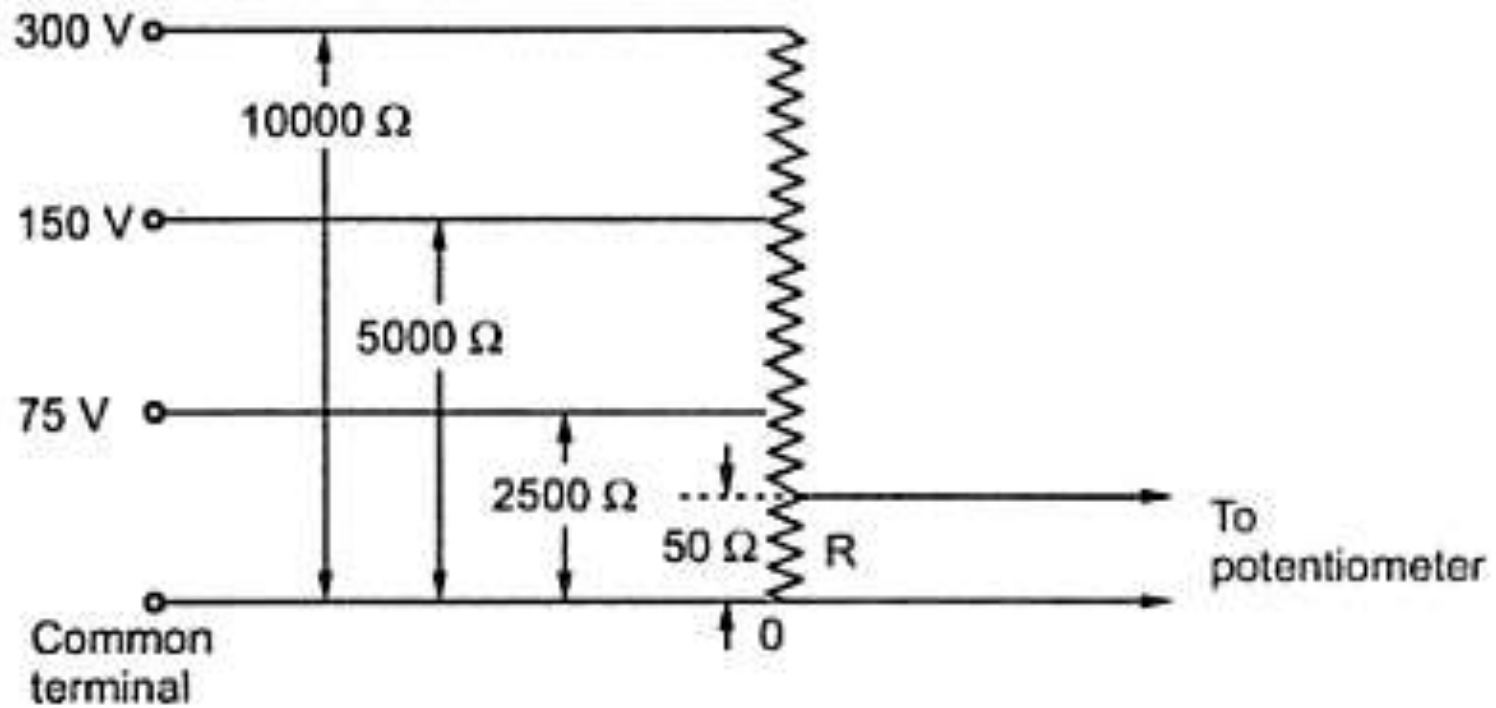

Volt-ratio box

$$V_{\text{unknown}} = 1.3 \left(\frac{5000}{50} \right) = 130 \text{ V}$$

Applications

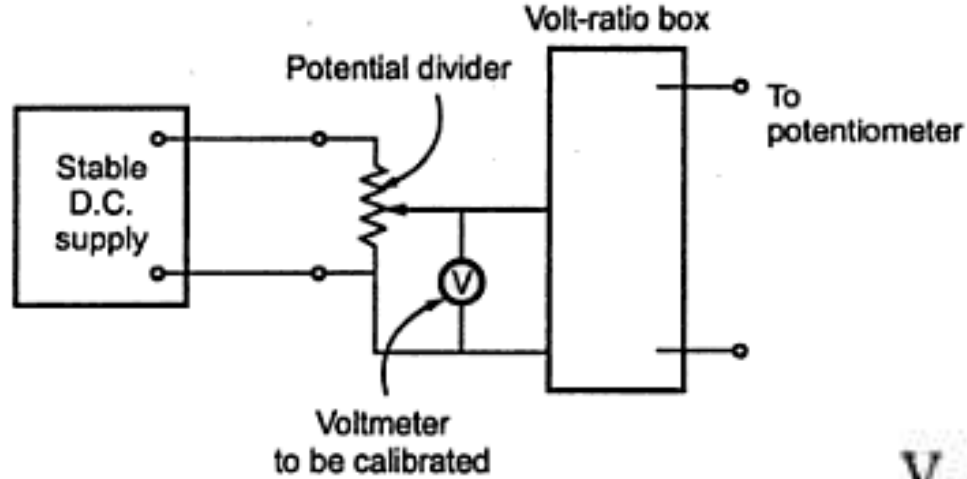

(a)

$$V_{\text{act}} = \frac{\text{(Potentiometer reading)}}{\text{(V.R. box ratio)}}$$

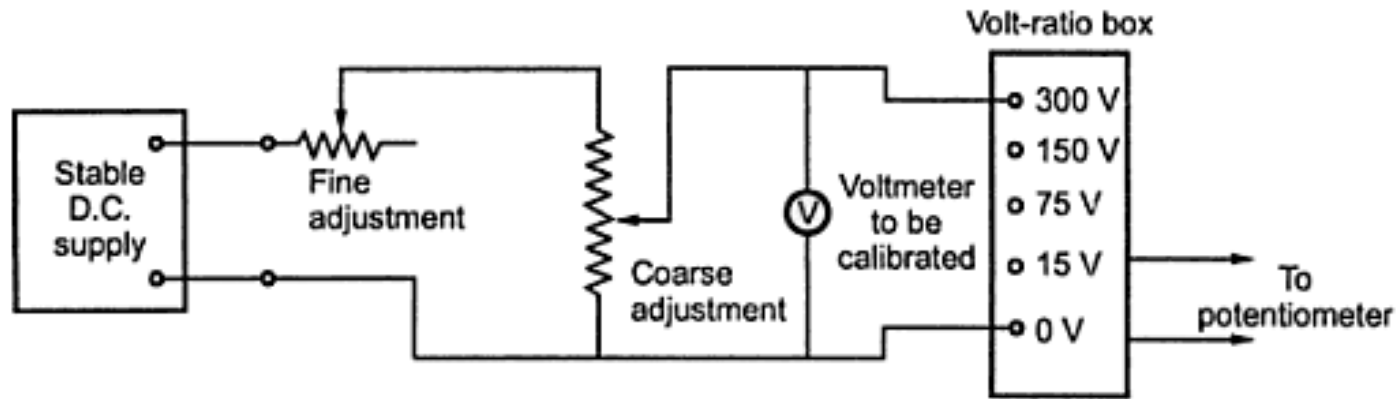

(b)

Calibration of voltmeter

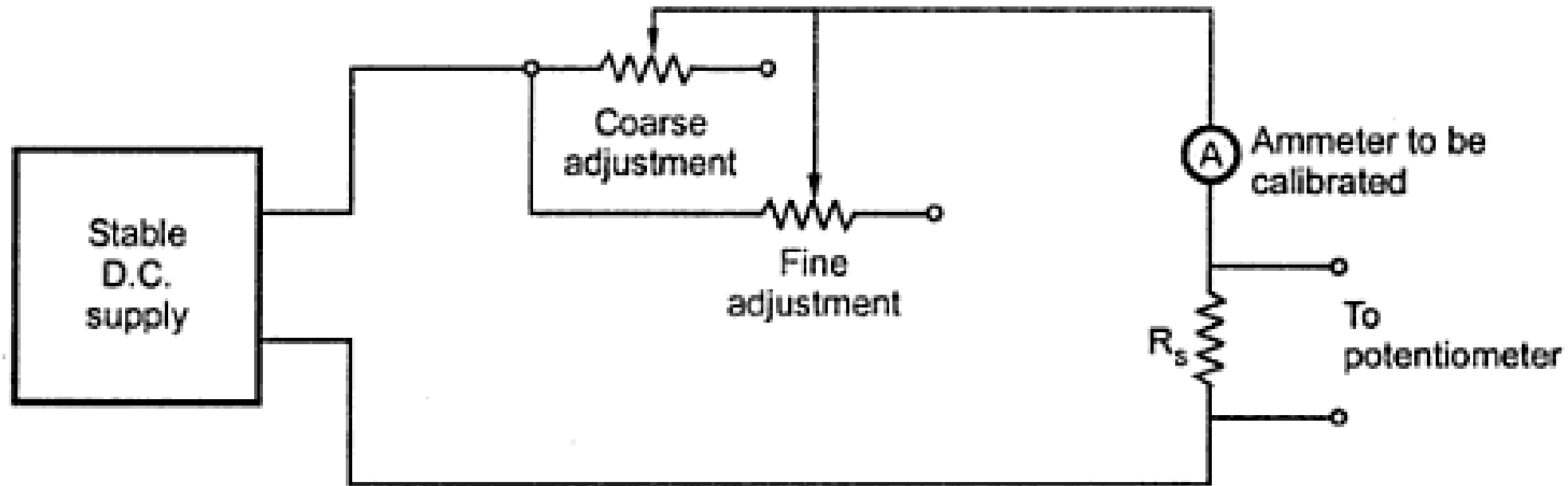

Calibration of ammeter

$$I = \frac{V_s}{R_s}$$

where

V_s = voltage across R_s measured using potentiometer

R_s = resistance of standard resistor

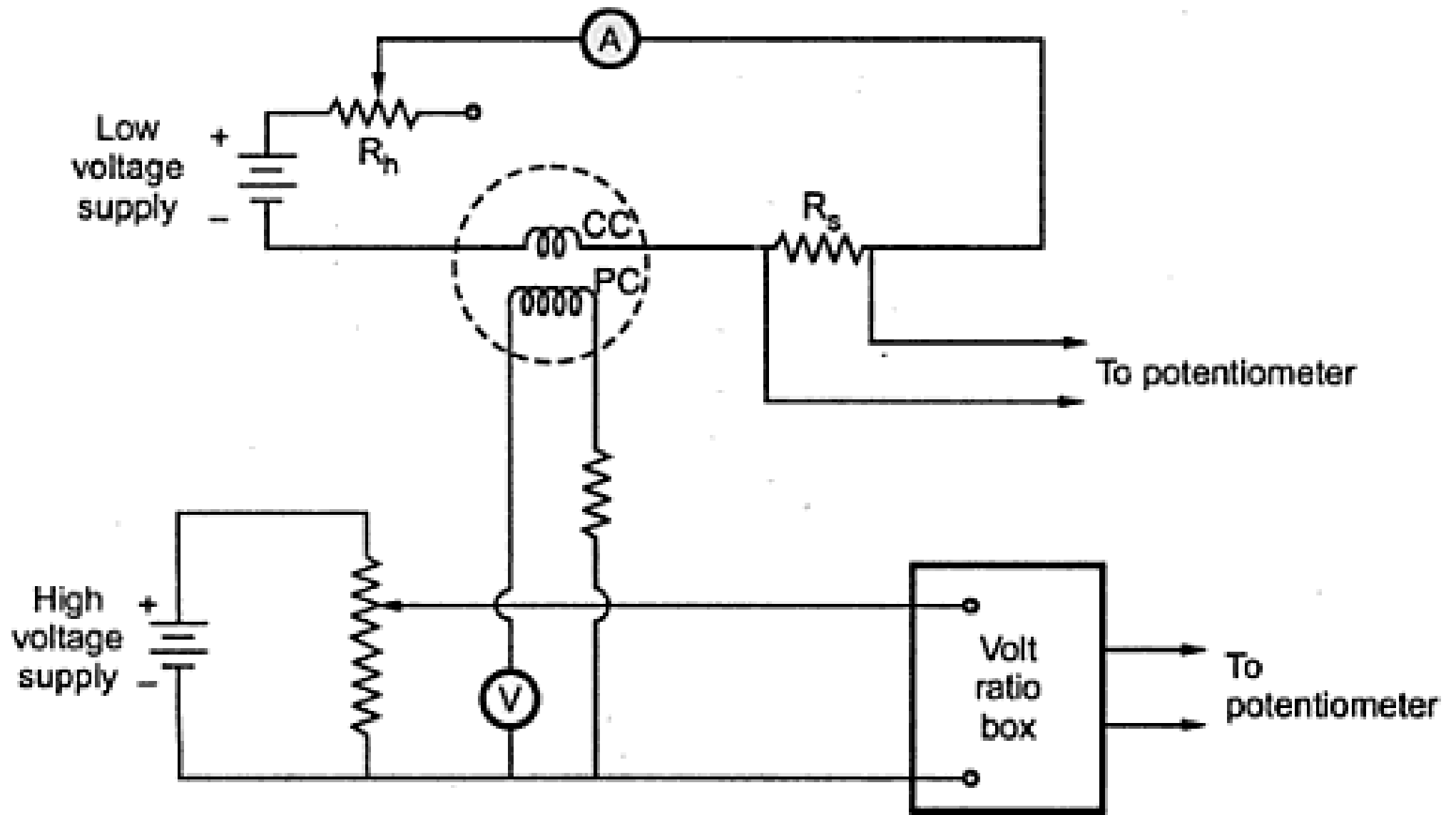

Calibration of wattmeter

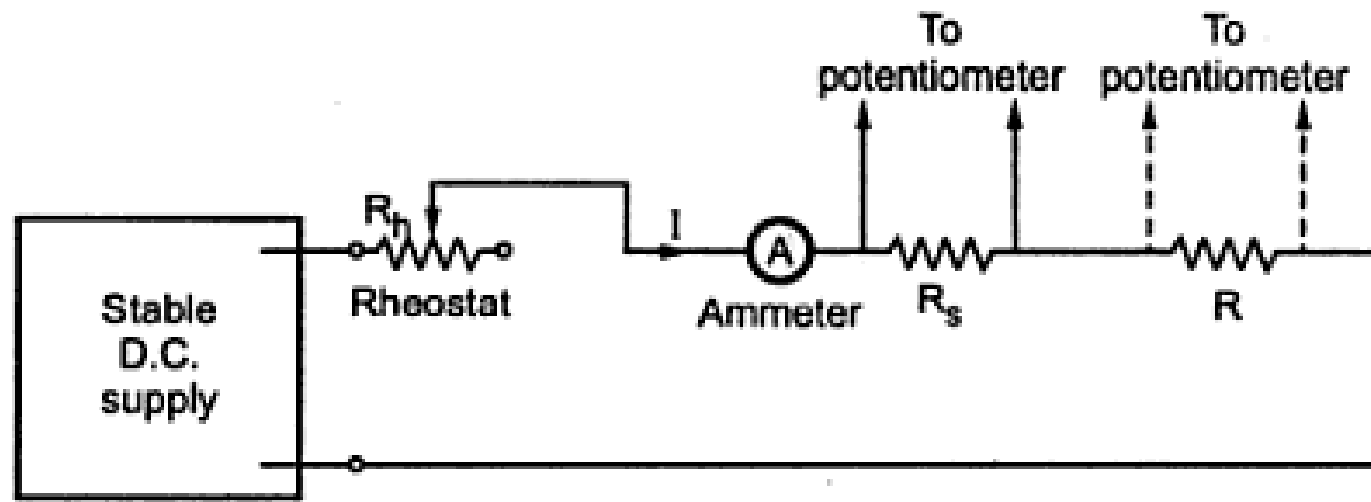

Measurement of unknown resistance

Let the voltage across standard resistance be V_{RS} . Then, we can write,

$$V_{RS} = I R_s$$

Let the voltage across unknown resistance be V_R . Then, we can write,

$$V_R = I R$$

Dividing equation (2) by equation (1),

$$\frac{V_R}{V_{RS}} = \frac{R}{R_s}$$

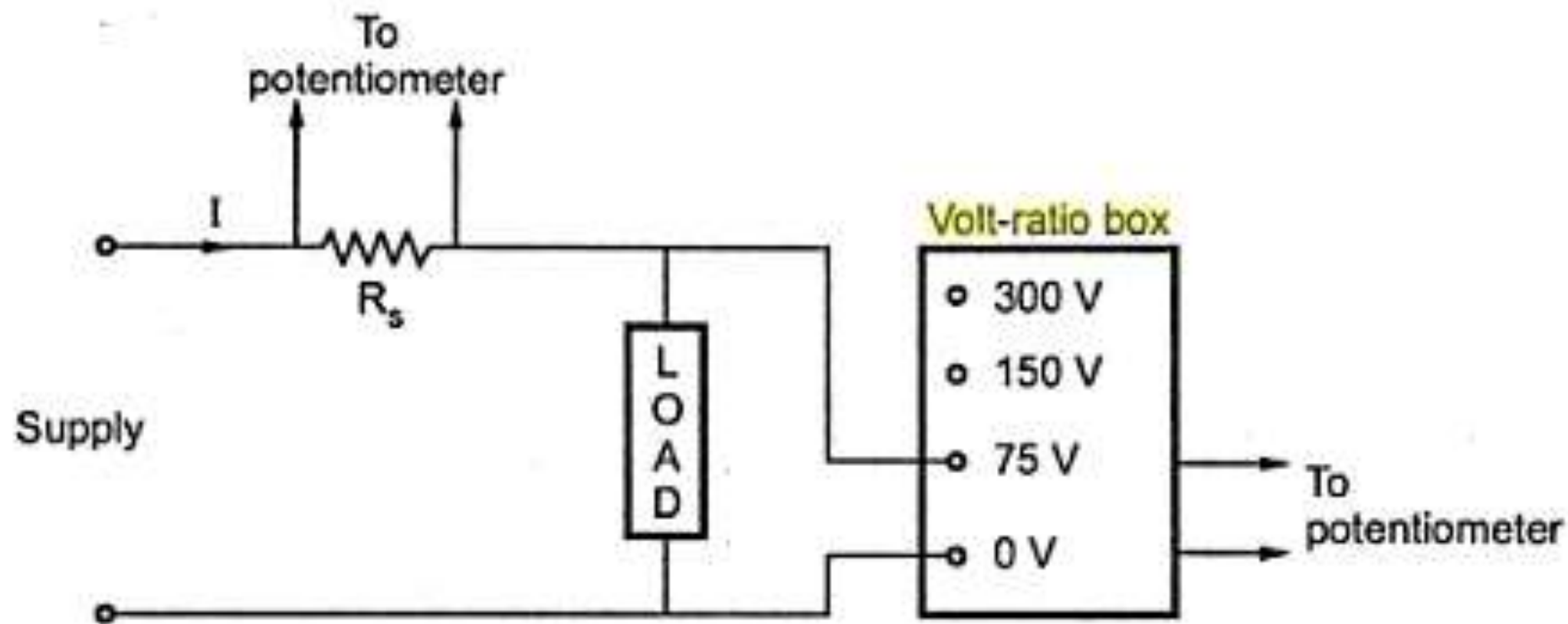

Measurement of power

AC potentiometer

An ac potentiometer measures the unknown ac voltage or emf similar to dc potentiometers used for measuring dc voltage. The balance condition is obtained when the unknown voltage is equal to the drop across the sliding wire of the potentiometer. It measures the unknown voltage both in terms of magnitude and phase angle by comparing and balancing it with the known reference voltage.

Although the working principle of the ac potentiometer is similar to that of the dc potentiometer (i.e., comparing unknown voltage with a known voltage). But dc potentiometer cannot be used for measuring the ac voltage.

AC potentiometer

- In **dc potentiometer**, the balance between voltage drop across the slide wire and the magnitude of unknown voltage is obtained.
- In **ac potentiometer**, the two voltages should be balanced in magnitude as well as in phase.

Two types of ac potentiometer,

- Polar type ac potentiometer.
- Co-ordinate type ac potentiometer.

Drysdale-Tinsley polar type ac potentiometer

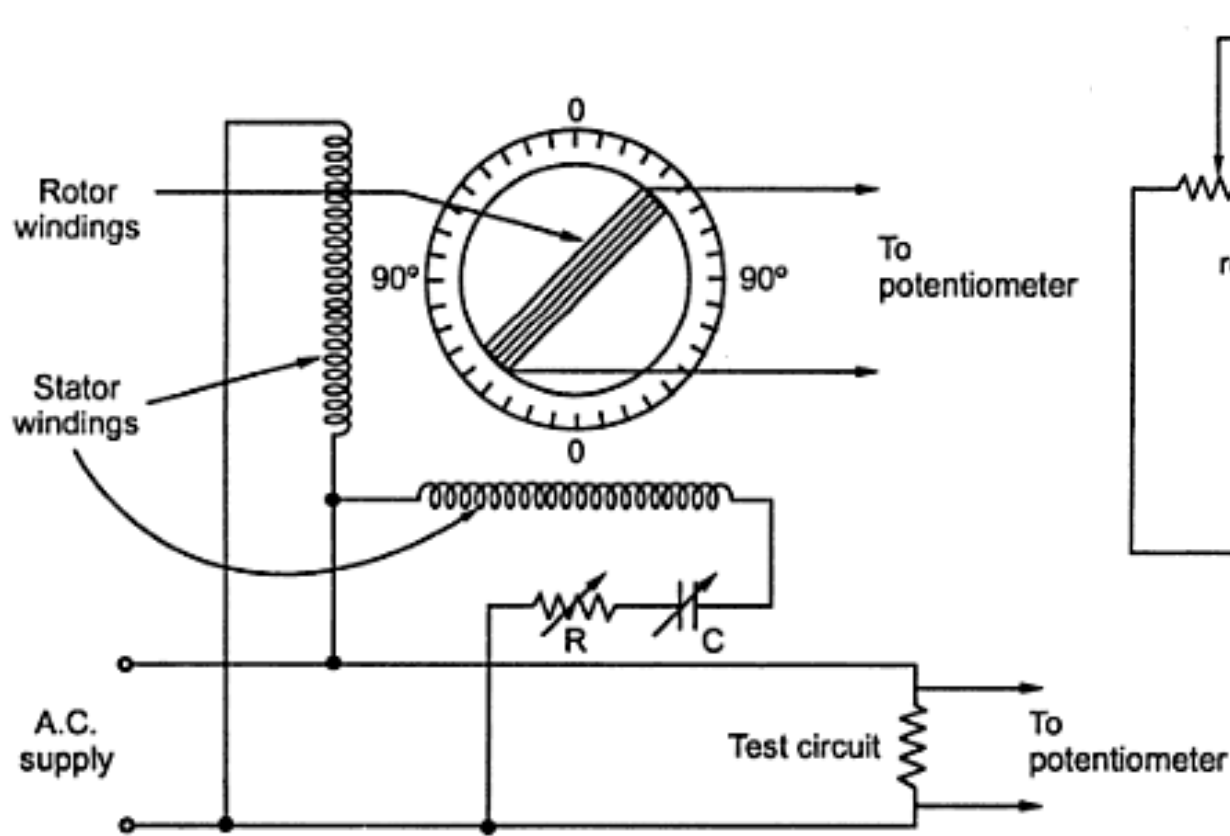

Drysdale phase shifter connection diagram

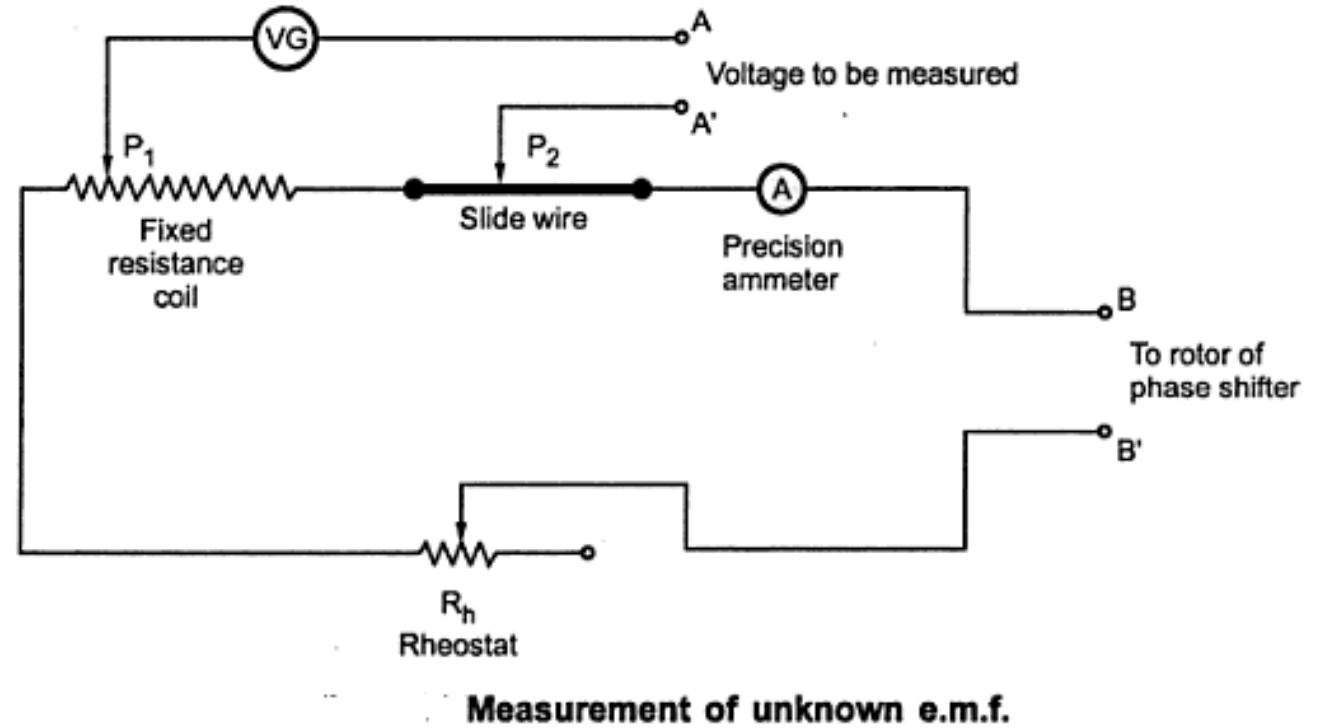

Measurement of unknown e.m.f.

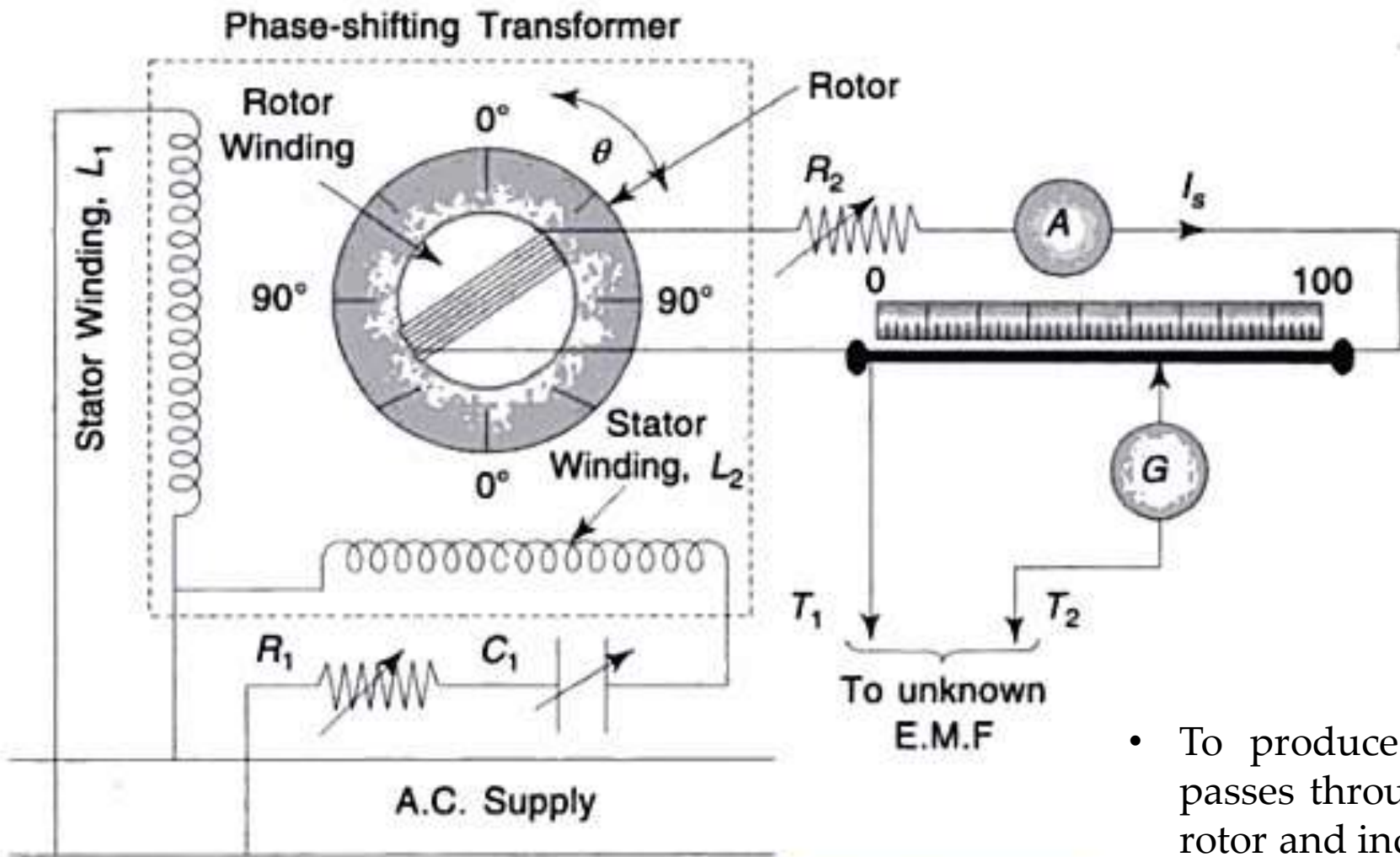

Drysdale Polar Potentiometer

- In a phase-shifting transformer, there is a combination of two ring-shaped laminated steel stators connected perpendicularly to each other.
- One is directly connected to power supply and the other one is connected in series with variable resistance and capacitor.
- Between the stators, there is laminated rotor having slots and winding which supplies voltage to the slide-wire circuit of the potentiometer.
- To produce the rotating magnetic field which passes through the air gap between its stator and rotor and induces an emf in the rotor winding.
- To provide the required phase shifting of the rotor induced emf by adjusting the rotor position. The rotor position can be adjusted by adjusting the rotor angle with respect to the null pointer.

Now, the induced emf in the rotor windings due to two stator windings is given by,

$$E_1 = KI \sin\omega t \cos\theta$$

$$E_2 = KI \sin(\omega t + 90) \cos(\theta + 90)$$

Therefore, the resultant emf is given by,

$$E = E_1 + E_2$$

$$E = KI [\sin\omega t \cos\theta + \sin(\omega t + 90) \cos(\theta + 90)]$$

We know that $\sin(\omega t + 90) = \cos\omega t$ and $\cos(\theta + 90) = -\sin\theta$.

$$\therefore E = KI \sin\omega t (\omega t - \theta)$$

From the above, it is clear that the rotor emf has constant amplitude and the phase angle is given by the rotor deflection θ .

Gall-Tinsley Co-ordinate type ac potentiometer

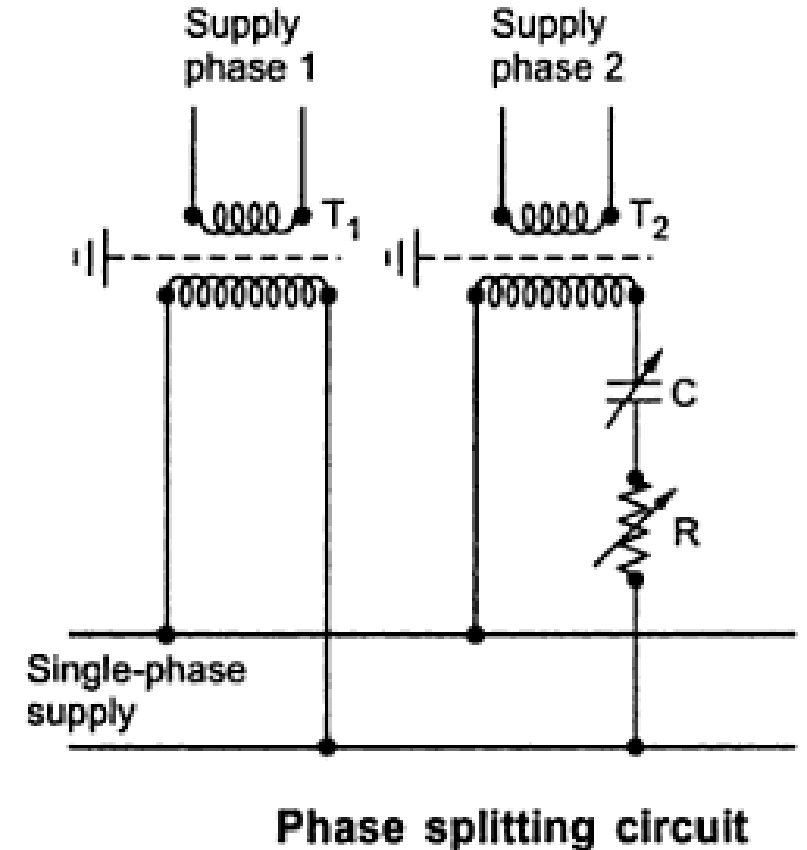
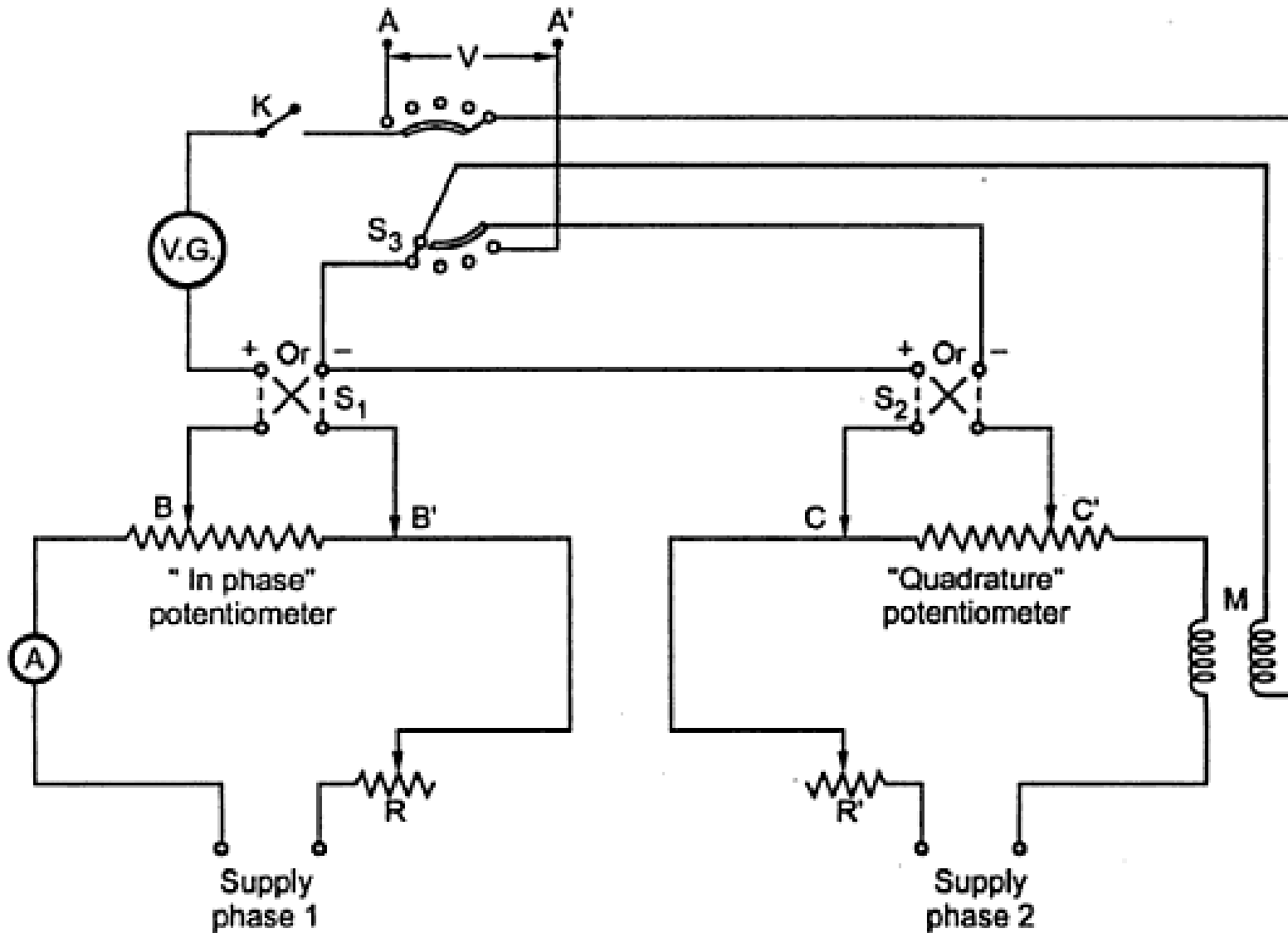

Connections of Gall-Tinsley potentiometers

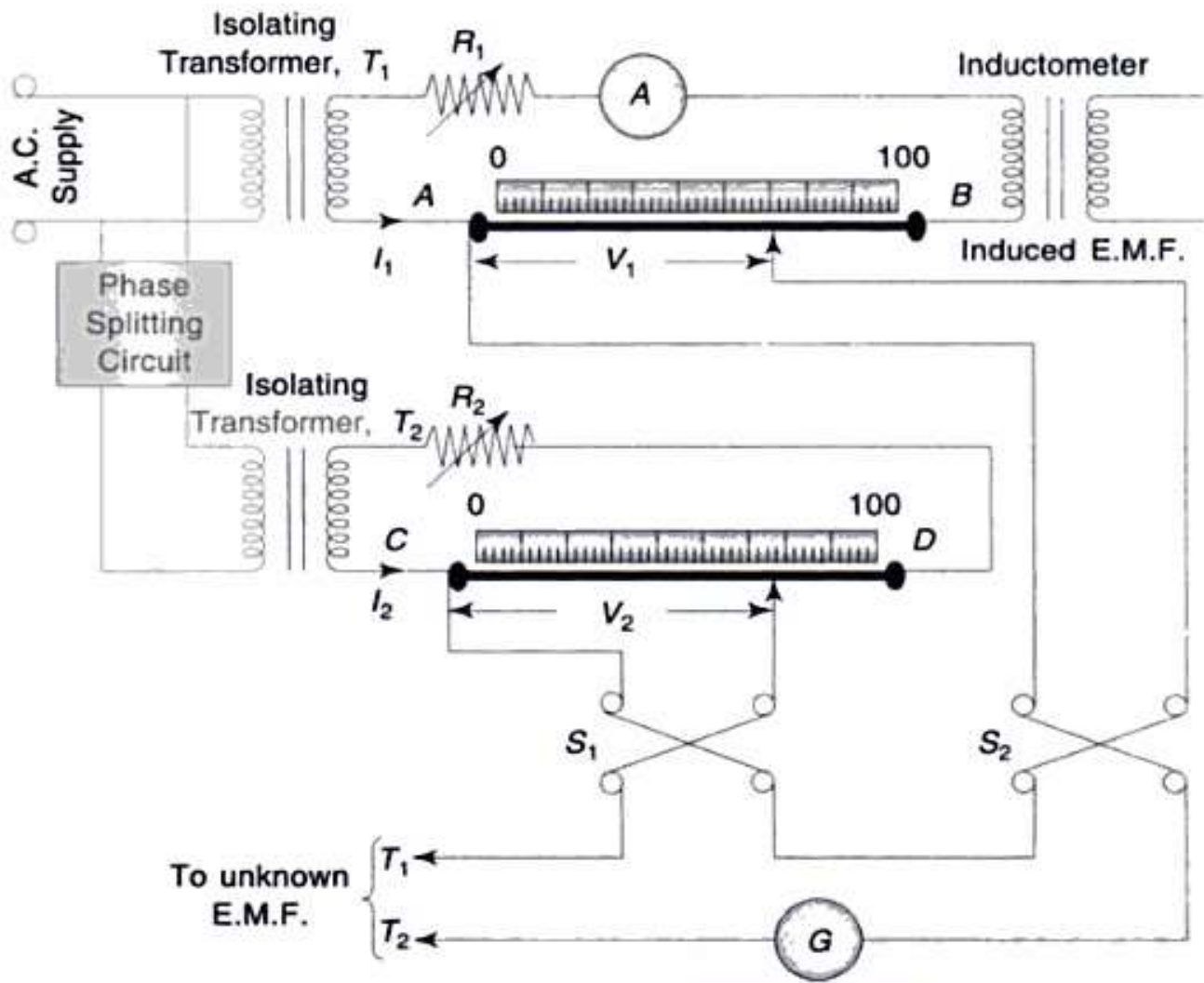

Fig. 2.38 Gall-Tinsley Potentiometer

Now to measure unknown e.m.f. its terminals are connected across sliding contacts AA' using selector switch S_3 . By doing some adjustments in sliding contacts and rheostat, the whole circuit gets balanced and galvanometer reads zero at the balanced condition. Now the in-phase component V_A of the unknown e.m.f. is obtained from the in-phase potentiometer and quadrature component V_B is obtained from quadrature potentiometer.

- The first one is named as the in-phase potentiometer which is used to measure the in-phase factor of an unknown e.m.f. and the other one is named as quadrature potentiometer which measures quadrature part of the unknown e.m.f. the sliding contact CD in the in-phase potentiometer and AB in quadrature potentiometer are used for obtaining the desired current in the circuit.
- By adjusting rheostat R1 and R2 and sliding contacts, the current in the quadrature potentiometer becomes equal to the current in the in-phase potentiometer and a variable galvanometer shows the null value. S_1 and S_2 are signs changing switches which are used to change the polarity of the test voltage if it is required for balancing the potentiometer.

Applications of Ac potentiometers

- Calibration of voltmeter
- Calibration of ammeter
- Testing of energymeter and wattmeter
- Measurement of self reactance of coil

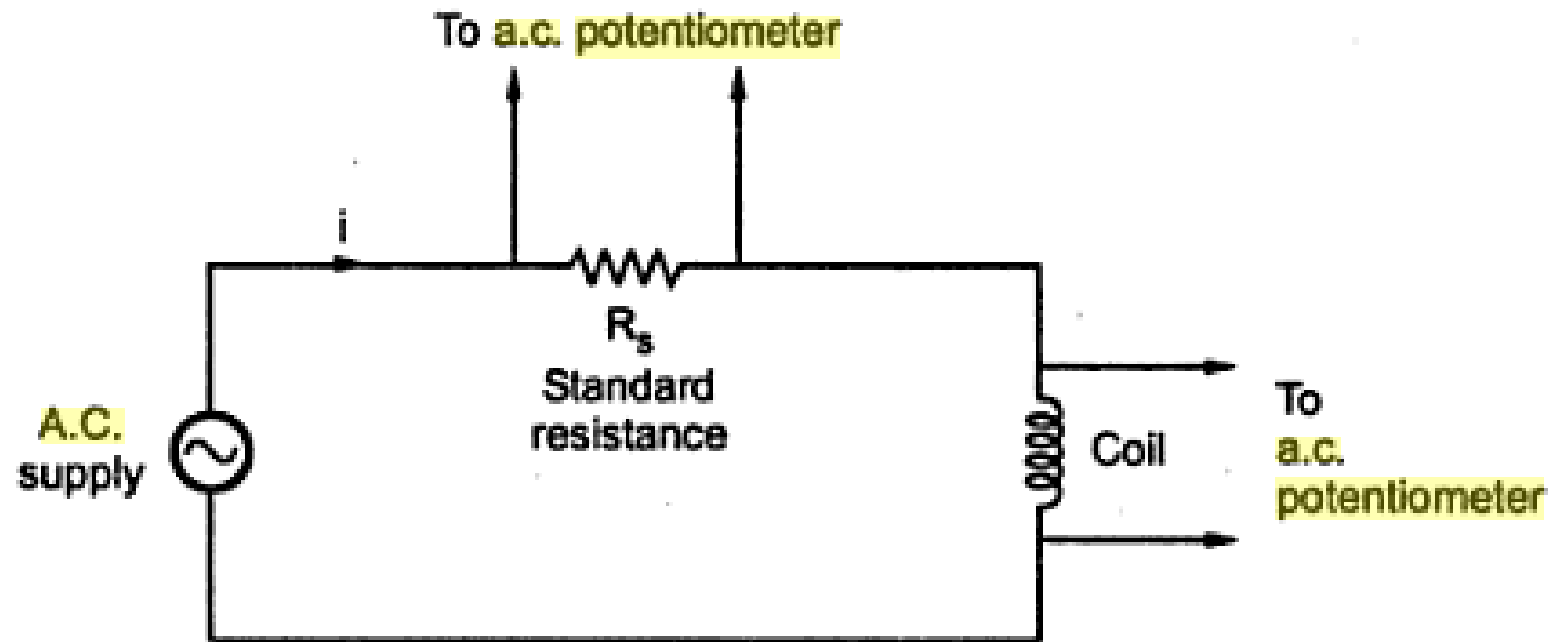

Measurement of self reactance of coil

$$\text{Voltage across coil} = v_c = V_c \angle \theta_c \quad \text{in polar form} \quad \dots (1)$$

$$\text{Voltage across } R_s = v_s = V_s \angle \theta_s \quad \dots (2)$$

The current through coil can be calculated as,

$$i = \frac{v_s}{R_s} = \frac{V_s \angle \theta_s}{R_s} \quad \dots (3)$$

The impedance of coil can be calculated as,

$$Z = \frac{v_c}{i} = \frac{V_c \angle \theta_c}{\left[\frac{V_s \angle \theta_s}{R_s} \right]} = \frac{R_s V_c}{V_s} \angle \theta_c - \theta_s \quad \dots (4)$$

We can write this impedance Z in rectangular form in real part and imaginary part as resistance and reactance.

The resistive part of impedance is given by,

$$R = Z \cos (\theta_c - \theta_s) = \frac{R_s V_c}{V_s} \cos (\theta_c - \theta_s) \quad \dots (5)$$

The reactive part of impedance is given by,

$$X = Z \sin (\theta_c - \theta_s) = \frac{R_s V_c}{V_s} \sin (\theta_c - \theta_s) \quad \dots (6)$$

Thus equation (6) represents reactance of the coil.

Instrument transformer

Introduction

These are special type of transformers used for the measurement of voltage, current, power and energy. As the name suggests, these transformers are used in conjunction with the relevant instruments such as ammeters, voltmeters, watt meters and energy meters.

Types of Instrument Transformer

Such transformers are of two types :

1. **Current Transformer** (or Series Transformer)
2. **Potential Transformer** (or Parallel Transformer)

Current transformers are used when the magnitude of AC currents exceeds the safe value of current of measuring instruments.

Potential transformers are used where the voltage of an AC circuit exceeds 750 V as it is not possible to provide adequate insulation on measuring instruments for voltage more than this.

Uses of Instrument Transformer

It is used for the following two as:

1. To protect the high voltage circuit from the measuring circuit in order to protect the measuring instruments from burning
2. To make it possible to measure the high voltage with low range voltmeter and high current with low range ammeter.

These instrument transformers are also used in controlling and protecting circuits, to operate relays, circuit breakers etc. The working of these transformers are similar as that of ordinary transformers.

Use of Instrument Transformer

Measurement of current as CT

The primary winding is so connected that the current to be measured passes through it and the secondary is connected to the ammeter .

The function of CT is to step down the current.

Instrument Transformer as CT

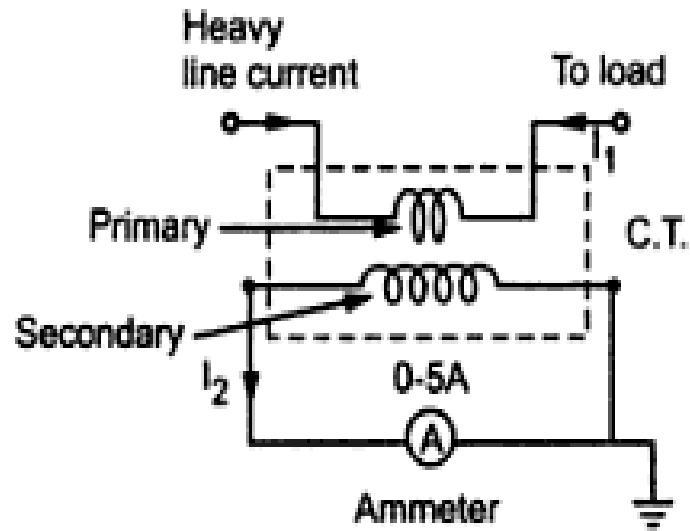

(a) Wound primary

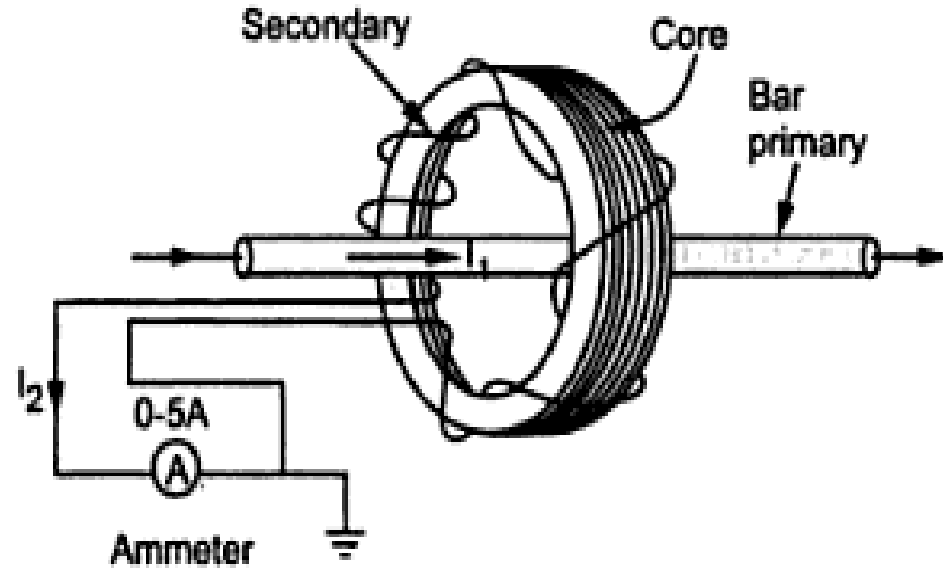

(b) Bar primary

Current transformer

Use of Instrument Transformer

Measurement of voltage by PT

The primary winding is connected to the voltage side to be measured and secondary to the voltmeter.

The function of PT is to steps down the voltage to the level of voltmeter.

Instrument Transformer as PT

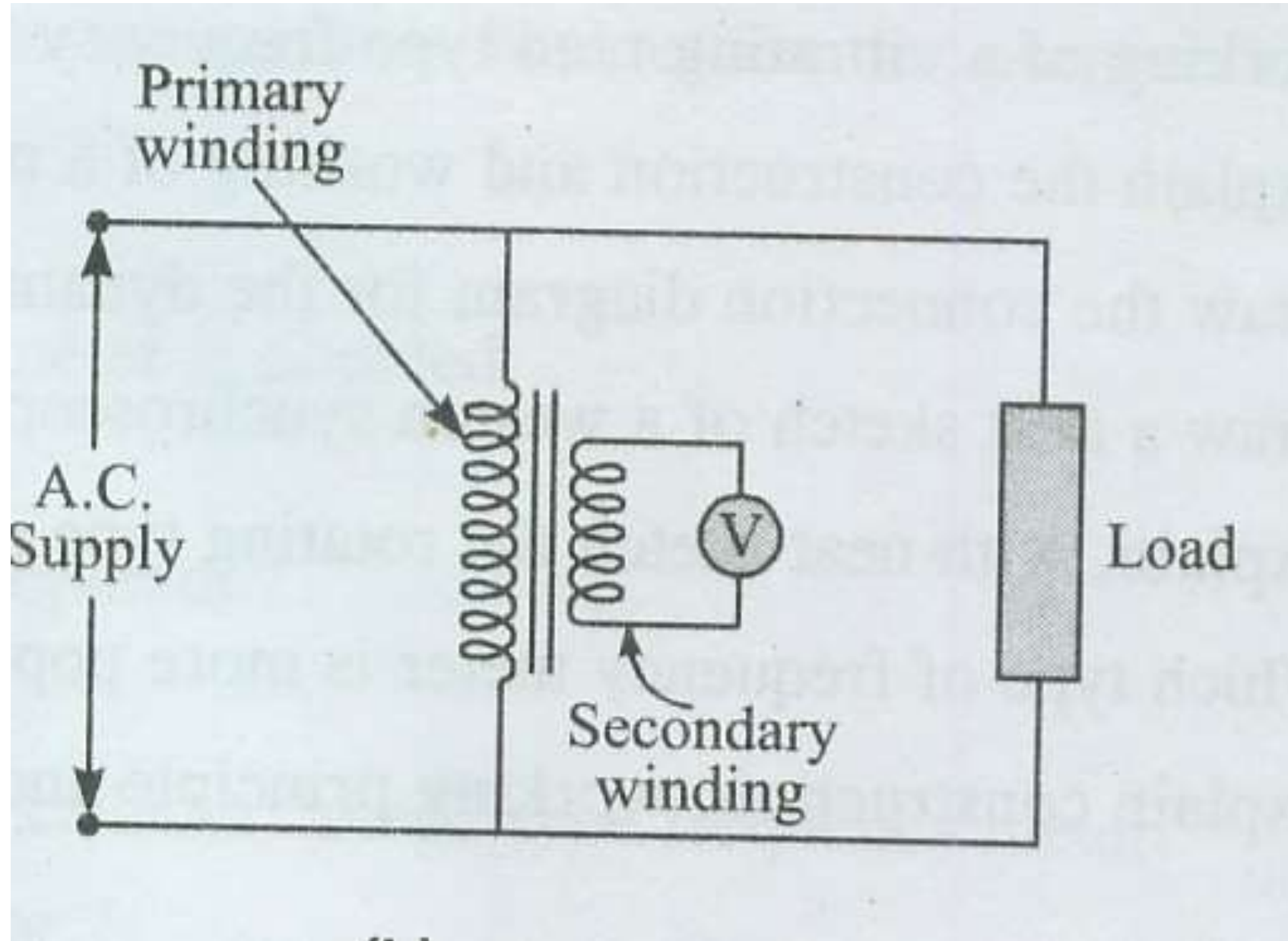

Advantages of Instrument Transformer

1. The measuring instruments can be placed far away from the high voltage side by connecting long wires to the instrument transformer. This ensures the safety of instruments as well as the operator.
2. Instrument transformers can be used to extend the range of measuring instruments like ammeters and voltmeters.
3. The power loss in instrument transformers is very small as compared to power loss due to the resistance of shunts and multipliers.
4. By using a current transformer with a tong tester, the current in a heavy current circuit can be measured.

Disadvantages of Instrument Transformer

1. The only main draw back is that these instruments can not be used in DC circuits.

Current Transformer (CT)

- A current transformer is an instrument transformer which is used to measure alternating current of large magnitude by stepping down by transformer action. The primary winding of CT is connected in series with the line in which current is to be measured and the secondary is connected to the ammeter.
- The secondary winding has very small load impedance which is the current coil of ammeter. The primary side has a few number of turns and the secondary side has large number of turns. The primary winding carries a full load current and this current is stepped down to a suitable value which is within the range of ammeter.

Current Transformer (CT)

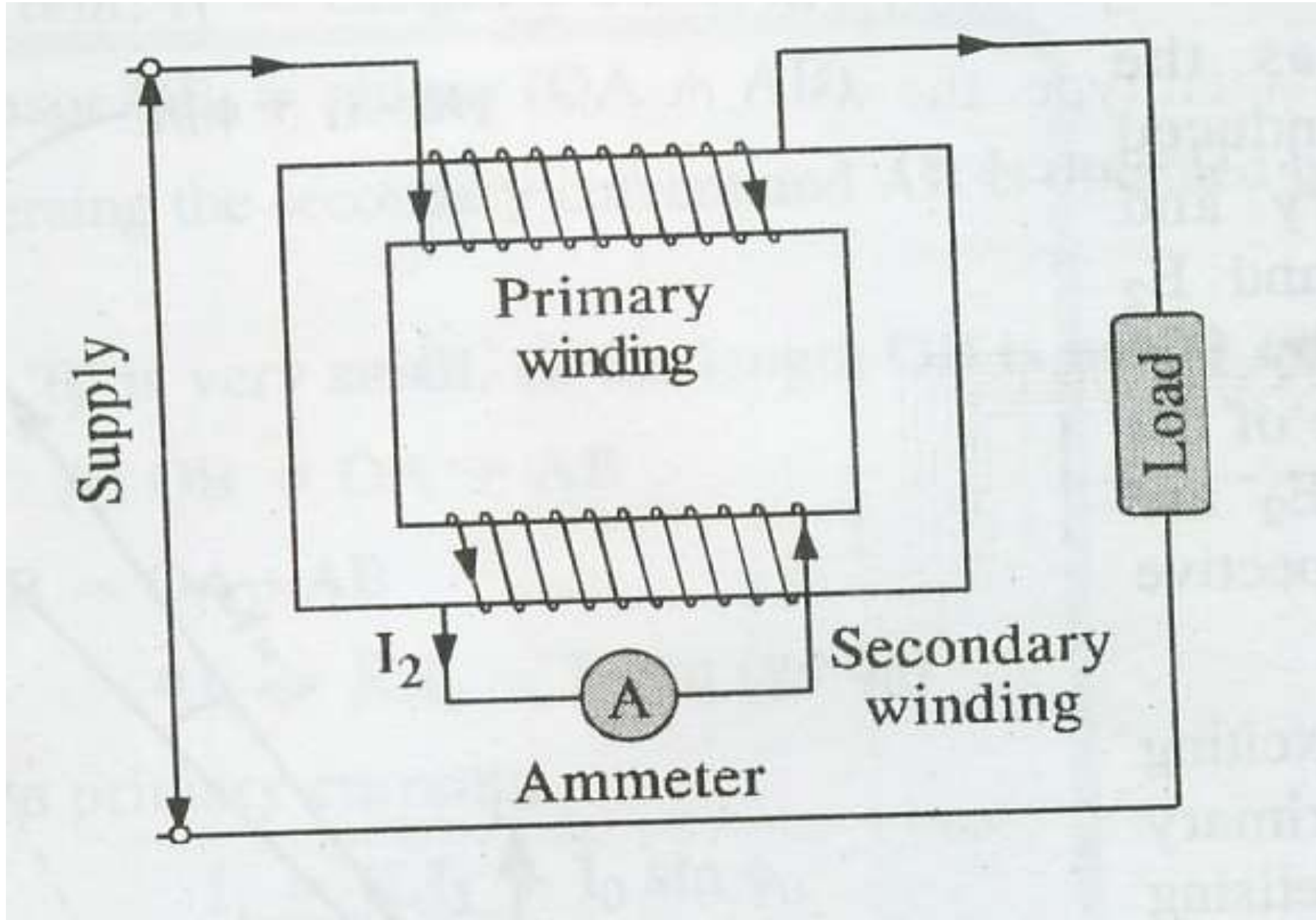

Measurement of power using CT and PT

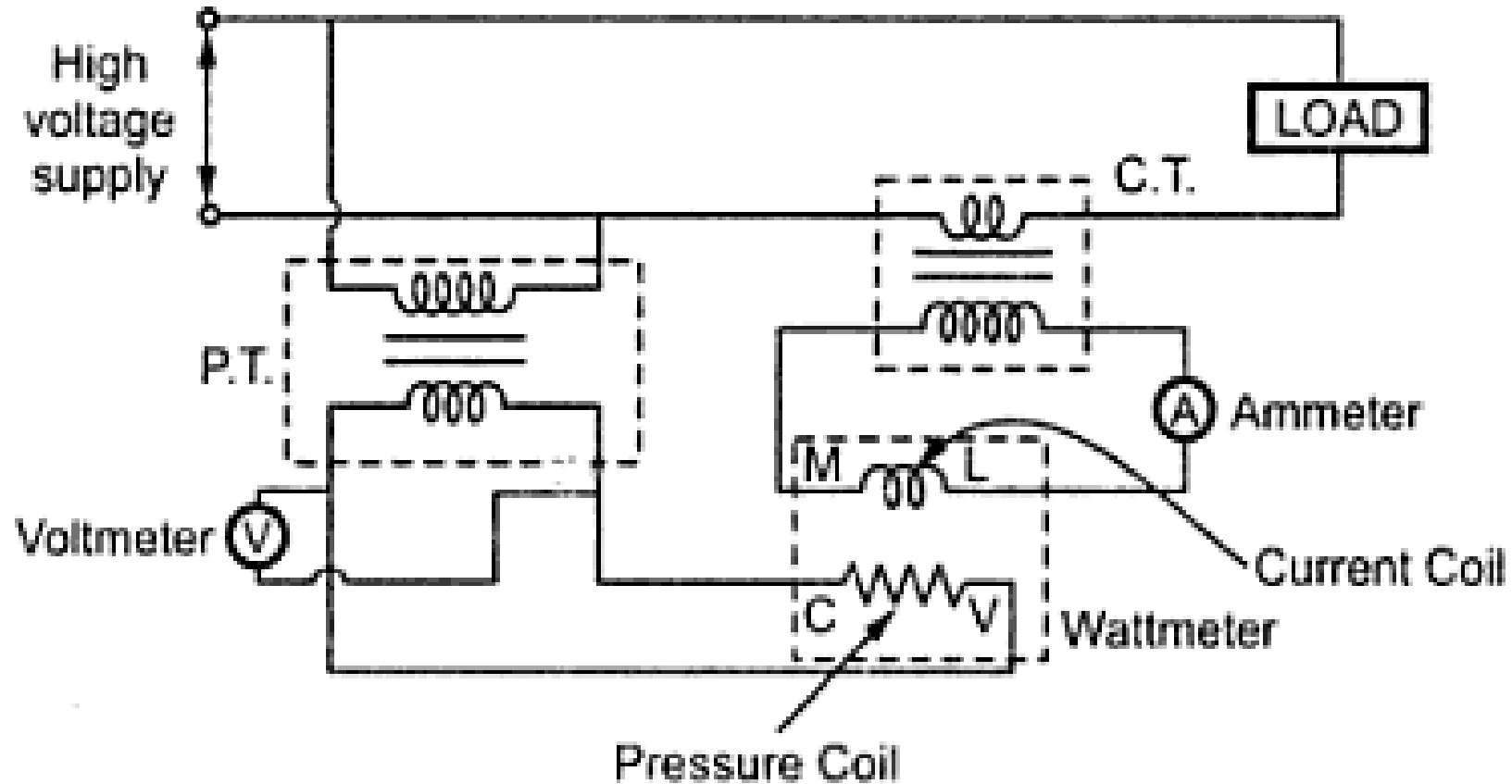

Power measurement using C.T. and P.T.

Measurement of energy using CT and PT

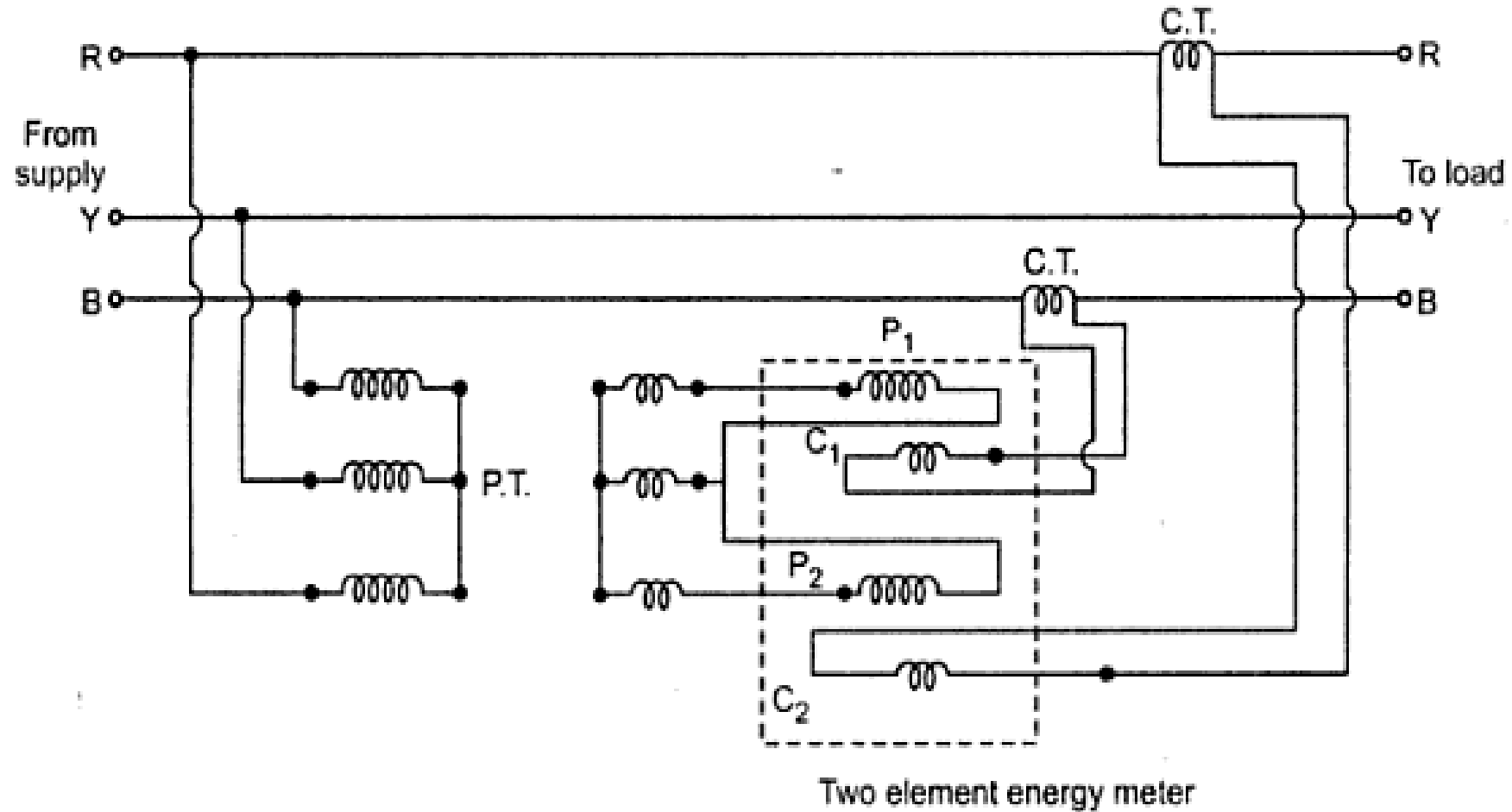

Two element energymeter with C.T. and P.T.

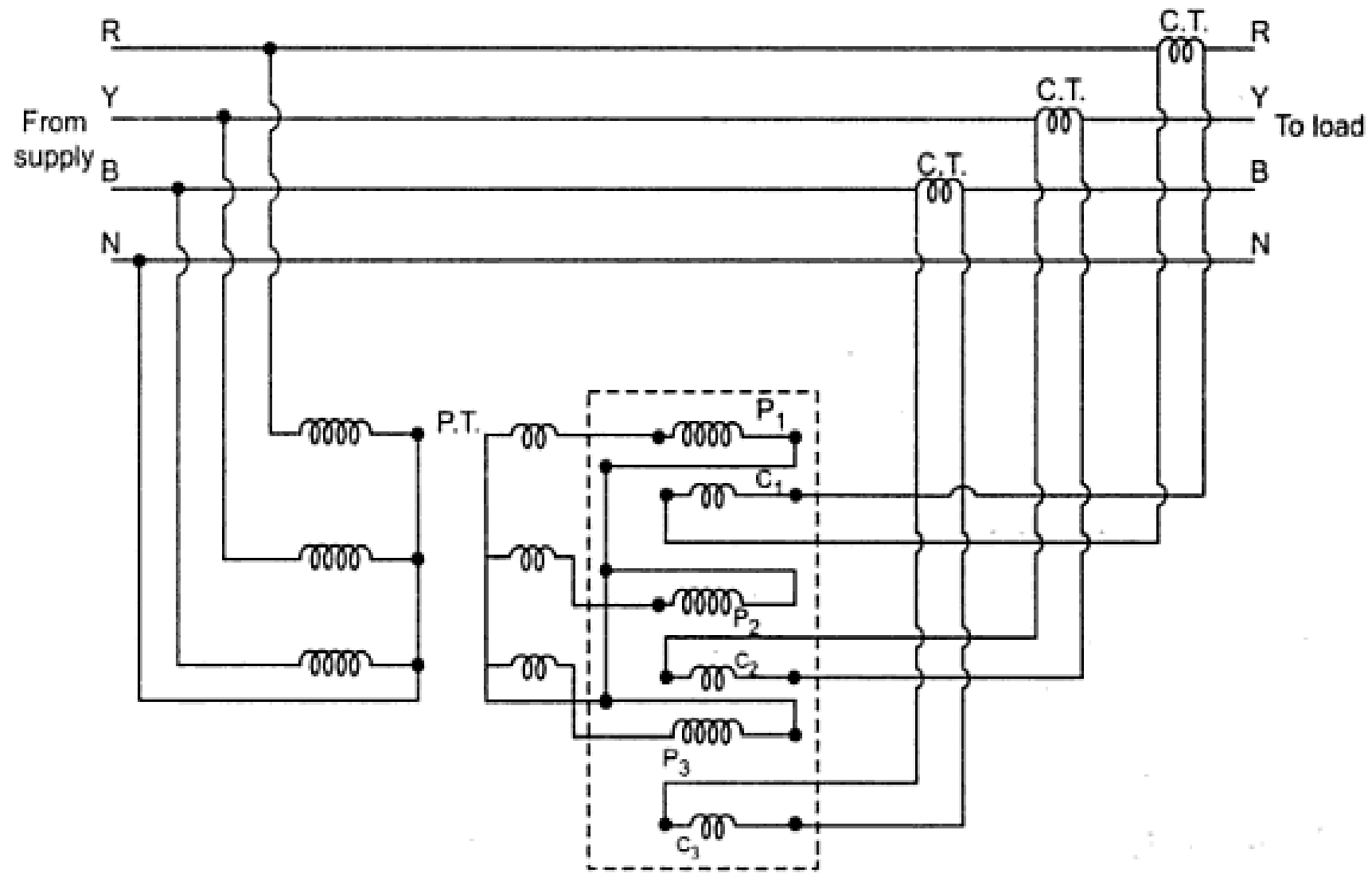

Three element energymeter with C.T. and P.T.

Comparison of C.T. and P.T.

Sr. No.	Current Transformer	Potential Transformer
1.	It can be treated as series transformer under virtual short circuit conditions.	It can be treated as parallel transformer under open circuit secondary.
2.	Secondary must be always shorted	Secondary is nearly under open circuit conditions.
3.	A small voltage exists across its terminals as connected in series.	Full line voltage appears across its terminals
4.	The winding carries full line current.	The winding is impressed with full line voltage.
5.	The primary current and excitation varies over a wide range.	The line voltage is almost constant hence exciting current and flux density varies over a limited range.
6.	The primary current is independent of the secondary circuit conditions.	The primary current depends on the secondary circuit conditions.
7.	Needs only one bushing as the two ends of primary winding are brought out through the same insulator. Hence there is saving in cost.	Two bushings are required when neither side of the line is at ground potential.

Ratios of Instrument Transformers

The various ratios defined for the instrument transformers are,

1. Actual ratio [R]

The actual transformation ratio is defined as the ratio of the magnitude of actual primary phasor to the corresponding magnitude of actual secondary phasor.

$$\begin{aligned}\therefore R &= \frac{\text{magnitude of actual primary current}}{\text{magnitude of actual secondary current}} && \dots \text{ For C.T.} \\ &= \frac{\text{magnitude of actual primary voltage}}{\text{magnitude of actual secondary voltage}} && \dots \text{ For P.T.}\end{aligned}$$

The actual ratio is also called **transformation ratio**.

2. Nominal ratio [K_n]

The nominal ratio is defined as the ratio of rated primary quantity to the rated secondary quantity, either current or voltage.

$$\begin{aligned}\therefore K_n &= \frac{\text{rated primary current}}{\text{rated secondary current}} && \dots \text{ For C.T.} \\ &= \frac{\text{rated primary voltage}}{\text{rated secondary voltage}} && \dots \text{ For P.T.}\end{aligned}$$

3. Turns ratio [n]

$$\begin{aligned}n &= \frac{\text{number of turns of secondary winding}}{\text{number of turns of primary winding}} && \dots \text{ For C.T.} \\ &= \frac{\text{number of turns of primary winding}}{\text{number of turns of secondary winding}} && \dots \text{ For P.T.}\end{aligned}$$

Theory of Current Transformers

Consider the equivalent circuit of a current transformer along with the load.

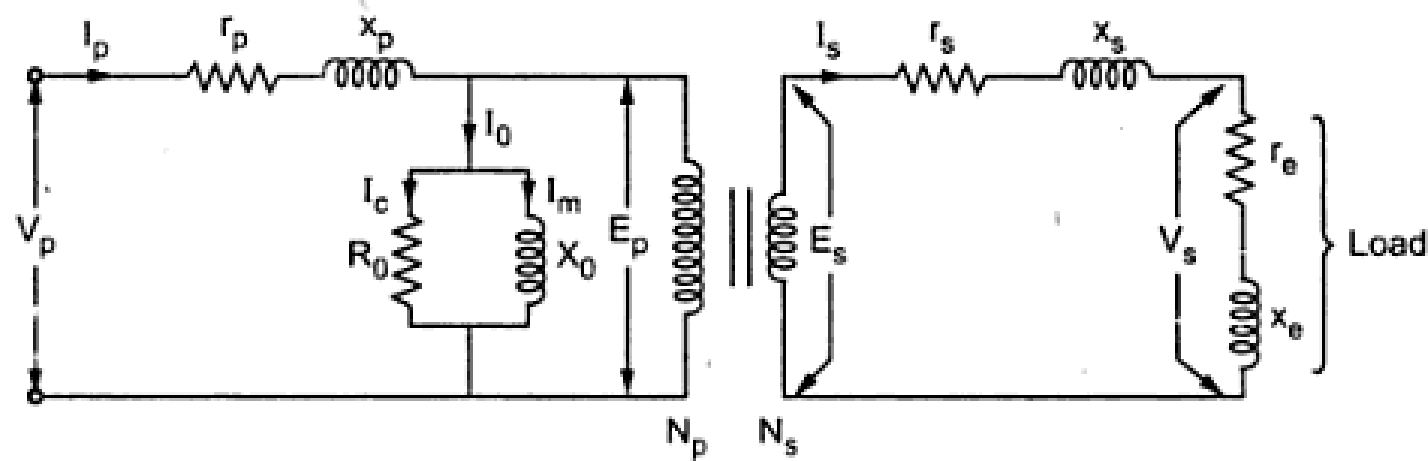

Fig. 2.84 Equivalent circuit of current transformer

The various symbols are,

$$n = \text{turns ratio} = \frac{\text{secondary turns}}{\text{primary turns}} = \frac{N_s}{N_p}$$

r_p = Resistance of primary winding

x_p = Reactance of primary winding

r_s = Resistance of secondary winding

x_s = Reactance of secondary winding

r_e = Resistance of external burden i.e. load on secondary

- x_e = Reactance of external burden i.e. load on secondary
- E_p = Primary induced voltage
- E_s = Secondary induced voltage
- V_s = Secondary terminal voltage
- I_p = Primary current
- I_s = Secondary current
- I_0 = No load current or exciting current
- I_c = Core loss component of I_0 i.e. $I_0 \cos \phi_0$
- I_m = Magnetising component of I_0 i.e. $I_0 \sin \phi_0$
- ϕ = Working flux of transformer
- δ = **Angle between E_s and I_s**
 = Phase angle of total impedance of secondary including burden
 = $\tan^{-1} \left(\frac{x_s + x_e}{r_s + r_e} \right)$
- θ = Phase angle of transformer
- Δ = Phase angle of load or burden i.e. $r_e + j x_e$
 = $\tan^{-1} \frac{x_e}{r_e}$
- α = **Angle between I_0 and working flux ϕ .**

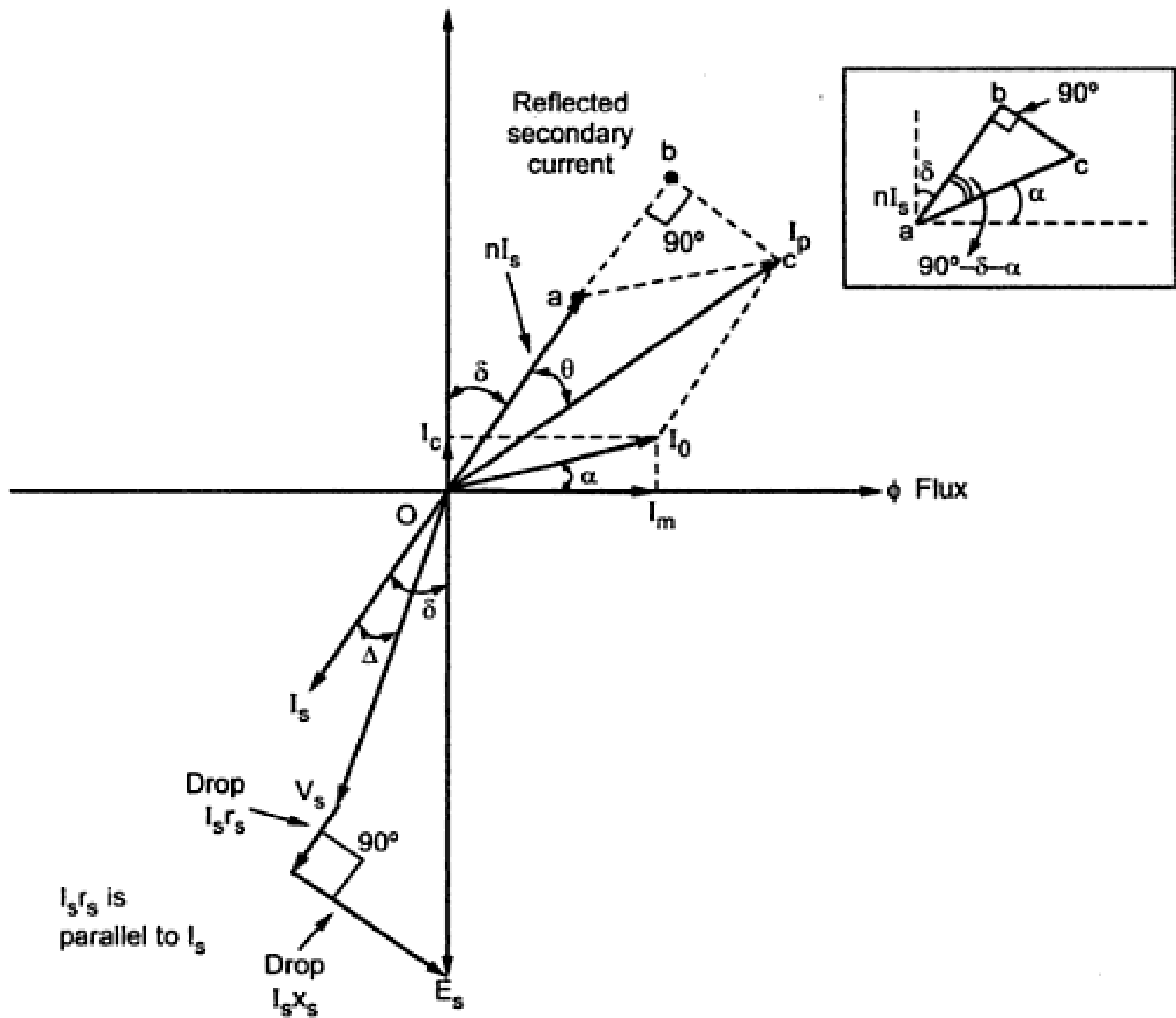

Phasor diagram of current transformer

Errors in CT

For an instrument transformer , the transformation ratio must be exactly equal to turns ratio and phase of secondary terms (vtg or Ct) must be displaced by exactly 180° from that of the primary terms.

There are two types of errors in these transformers :

1. Ratio error
2. Phase angle error

- **Ratio error**

For normal operation of these instrument transformers, the current transformation ratio (I_2/I_1) is equal to the turns ratio (N_1/N_2) should be constant and within the limits. It has been seen that this ratio are not constant but do vary with the power factor. So this error is known as Ratio Error.

Ratio error is defined as,

$$\% \text{ Ratio error} = \frac{\text{nominal ratio} - \text{actual ratio}}{\text{actual ratio}} \times 100$$

$$\% \text{ Ratio error} = \frac{K_n - R}{R} \times 100$$

Ratio Correction Factor

The ratio between actual ratio of current transformation and the nominal ratio is known as Ratio Correction Factor,

$$\begin{aligned} \text{R.C.F.} &= \text{Actual Ratio} / \text{Nominal Ratio} \\ &= R / K_N \end{aligned}$$

Burden of an Instrument transformer

- The nominal ratio of an instrument transformer, does not remain constant in practice as the load on the sec changes. It changes because of the effect of sec current, PF. For the particular class of transformer **the specific loading at rated sec winding voltage is specified**, such that the errors do not exceed the limits. Such a **permissible load is called burden** of an instrument transformer

- Phase angle error

The phase of secondary current must be displaced by exactly 180° from that of the primary current for CT and the phase of secondary voltage must be displaced by exactly 180° from that of the primary voltage for PT .But actually its is no so. This error is called phase angle error. The phase angle error is due to the no load current or exciting current

Characteristics of CT

- 1. Effect of power factor of secondary circuit
PF of the sec. circuit depends on the PF of the burden(load) of sec. This affects
 - a. **Ratio error**: Inductive load $\rightarrow \delta$ is positive , $\sin(\delta+\alpha)$ is positive and hence $R > n$. For capacitive load $\rightarrow \delta$ is negative , $\sin(\delta+\alpha)$ is positive and hence $R < n$.
 - b. **Phase angle error**: Inductive load $\rightarrow \delta$ is positive , then θ is positive. When δ approaches 90° load becomes highly inductive and θ is negative. For capacitive load $\rightarrow \delta$ is negative , then θ is always positive
- 2. Effect of change in I_p : I_p and I_s are directly related. For low I_p , I_o is dominating so errors are higher. For higher I_p , I_o is less so errors are less.

- 3. Effect of change of burden on secondary: When Sec winding circuit burden increases, sec flux increases, which induces more voltage on sec. Thus I_m and I_c increases to keep flux constant. Due to this errors increases.
- 4. Effect of change in frequency: When frequency increases, flux and flux density increases. So I_m and I_c decreases, hence errors also get reduced.

UNIT-III

Measurement of Power & Energy

Single phase dynamometer wattmeter, LPF and UPF, Double element and three element dynamometer wattmeter, expression for deflecting and control torques – Extension of range of wattmeter using instrument transformers – Measurement of active and reactive powers in balanced and unbalanced systems. Single phase induction type energy meter – driving and braking torques – errors and compensations – testing by phantom loading using R.S.S.meter. Three phase energy meter – tri-vector meter, maximum demand meters.

Electrodynamo-meter Wattmeter.

Definition: The instrument whose working depends on the reaction between the magnetic field of moving and fixed coils is known as the Electro-dynamo-meter Wattmeter. It uses for measuring the power of both the AC and DC circuits.

working principle of the Electro-dynamometer

Their working depends on the theory that the current carrying conductor placed in a magnetic field experiences a mechanical force. This mechanical force deflects the pointer which is mounted on the calibrated scale

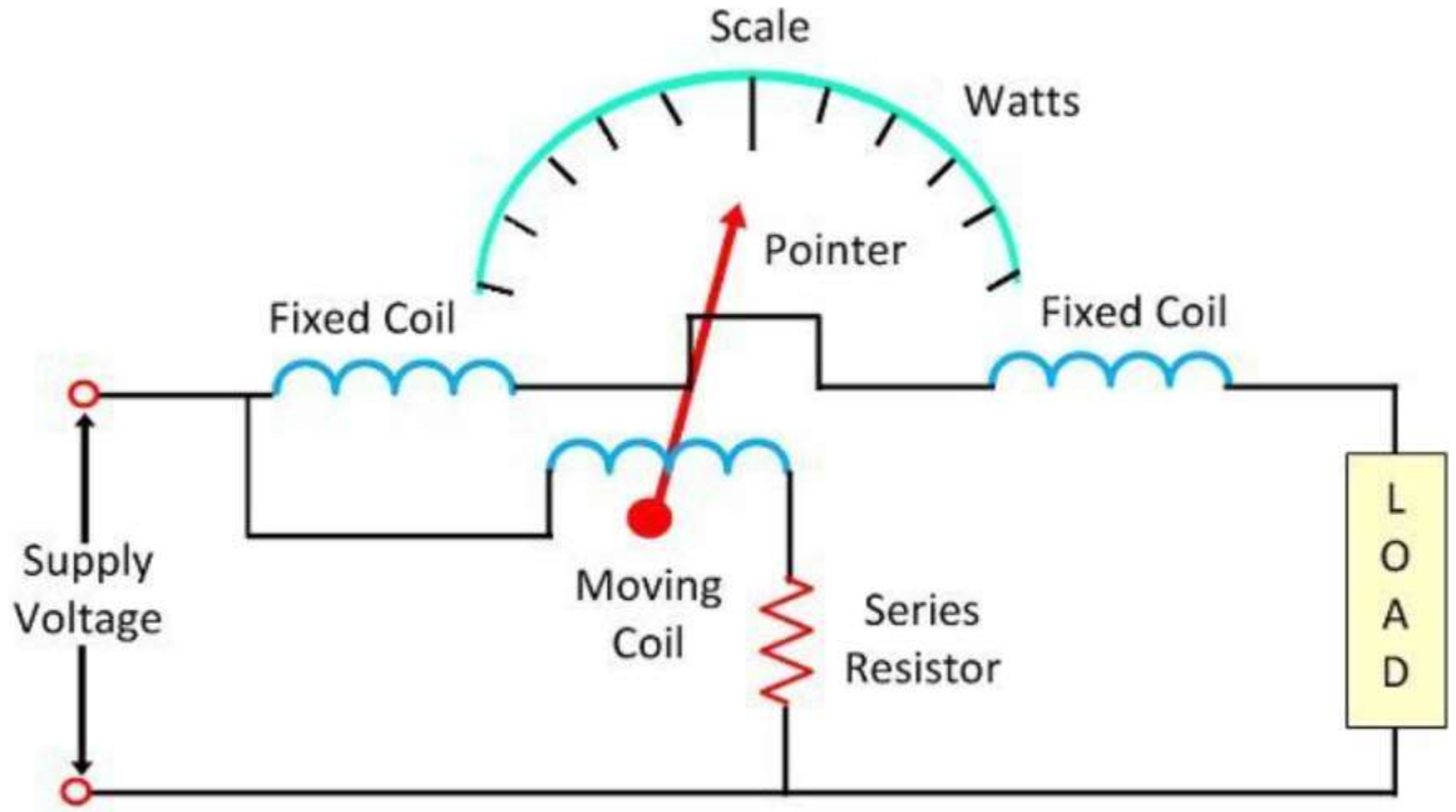

Electrodynamometer Wattmeter

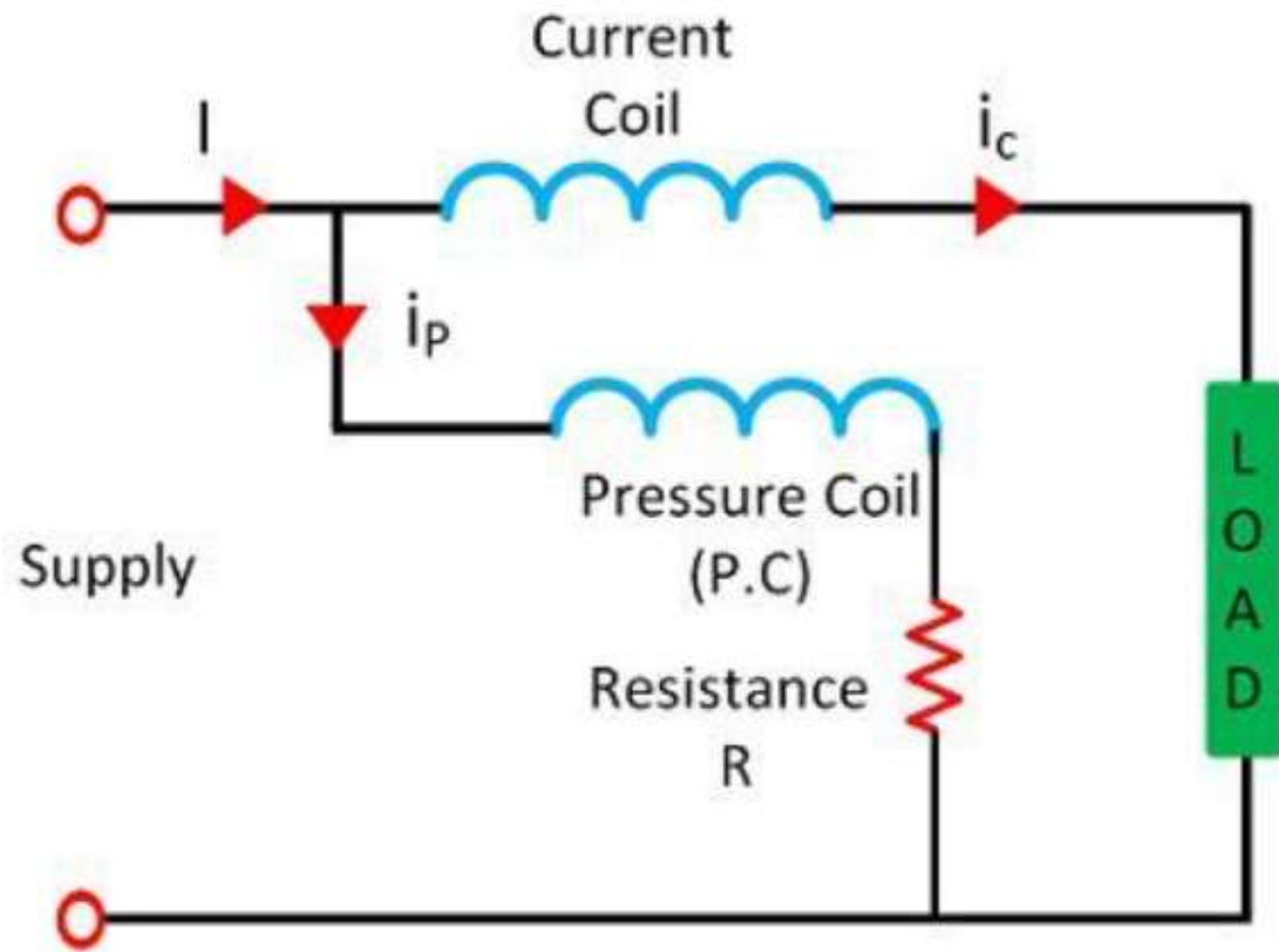

Circuit of Electrodynamo Wattmeter

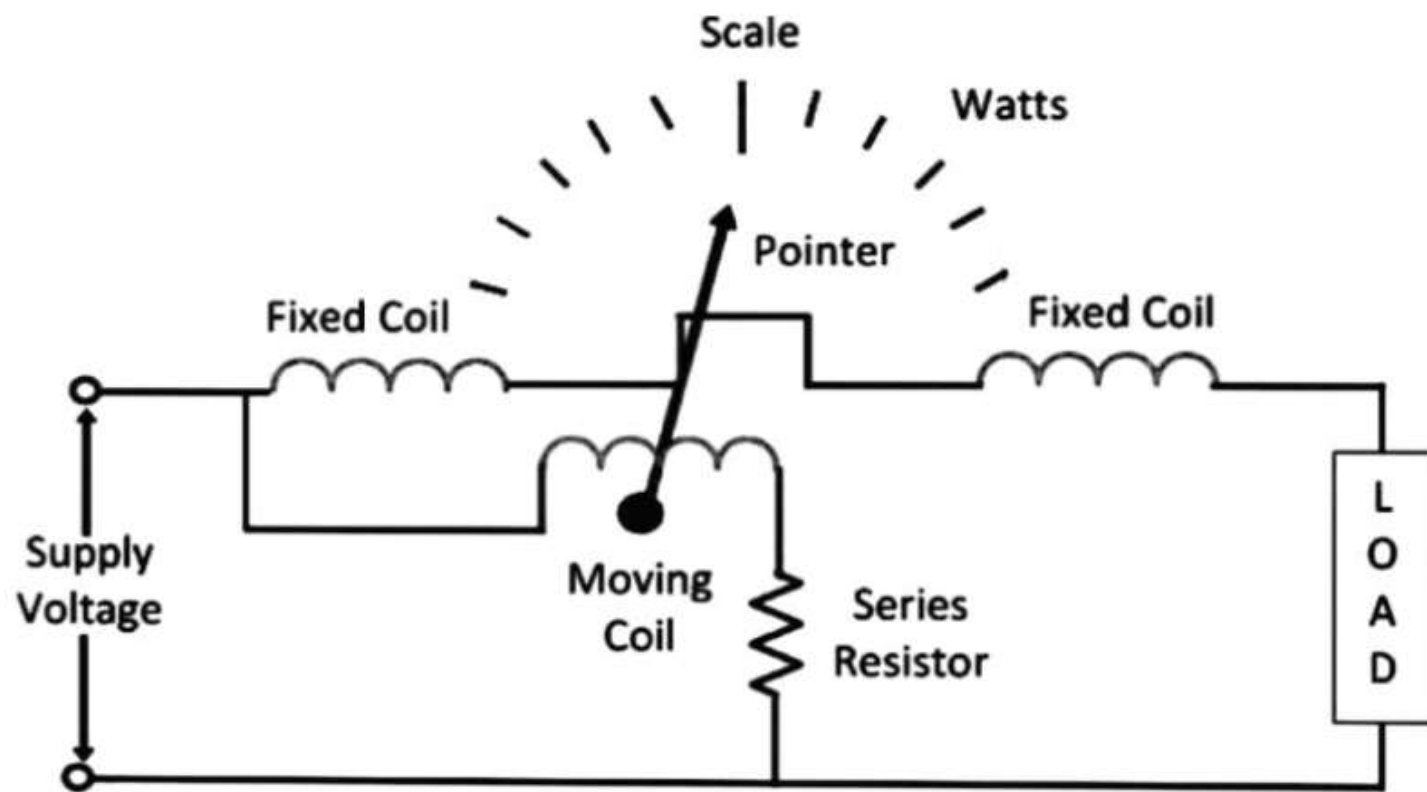

Construction of Electrodynamometer Wattmeter

1.Fixed coil :

The fixed coil connects in series with the load. It is considered as a current coil because the load current flows through it. **For making the construction easy the fixed coil divide into two parts.** The fixed coil produces the uniform electric field which is essentials for the working of the instruments. The current coil of the instruments is designed to carry the current of approximately 20 amperes for saving the power.

2. Moving Coil :

The moving coil consider as the pressure coil of the instruments. It connects in parallel with the supply voltage. The current flows through them is directly proportional to the supply voltage. The pointer mounts on the moving coil. The movement of the pointer controls with the help of the spring.

The current flows through the coil increases their temperature. The flows of currents control with the help of resistor which connects in series with the moving coil.

3. Control :

The control system provides the controlling torque to the instruments. Electrodynamometer Wattmeter uses spring control system.

4. Damping

The damping is the effect which reduces the movement of the pointer. **In this Wattmeter the damping torque produces because of the air friction.** The other types of damping are not used in the system because they destroy the useful magnetic flux.

5.Scales and pointers – The instruments use a linear scale because their moving coil moves linearly. The apparatus uses the knife edge pointer for removing the parallax error which causes because of oversights.

DC Input

Let V be the supply voltage

i be the load current

R be the resistance of the moving coil

Current through the fixed coil is $i_f = i$

Current through the moving coil is i_m

Since the moving coil is connected in parallel we can write

$$i_m = \frac{V}{R}$$

The deflecting torque is

$$T_d \propto i_f i_m \propto \frac{Vi}{R}$$

Since R is constant

$$T_d \propto Vi$$

Deflecting torque is thus proportional to power.

AC Input

The expression for instantaneous torque in AC is given by

$$T_i = i_1 i_2 \frac{dM}{d\theta}$$

$$T_i = i_p i_c \frac{dM}{d\theta} \quad (i)$$

Let the supply voltage is

$$v = \sqrt{2} V \sin \omega t$$

Let us assume that pressure coil has very high resistance and hence it is treated as a purely resistance. So,

$$i_p = \frac{v}{R} = \frac{\sqrt{2} V \sin \omega t}{R} = \sqrt{2} I_p \sin \omega t$$

Where

$$I_p = \frac{V}{R}$$

Since the current coil is inductive, let us assume that i_c will lag supply voltage v by some angle φ . So let

$$i_c = \sqrt{2} I \sin (\omega t - \varphi)$$

Substituting in equation (i) we get

$$\begin{aligned} T_i &= (\sqrt{2} I_p \sin \omega t)(\sqrt{2} I \sin (\omega t - \varphi)) \frac{dM}{d\theta} \\ &= 2I_p I \sin \omega t \sin (\omega t - \varphi) \frac{dM}{d\theta} \\ &= I_p I [\cos \varphi - \cos (2\omega t - \varphi)] \frac{dM}{d\theta} \end{aligned}$$

The average deflecting torque will be

$$\begin{aligned}T_d(\text{average}) &= \frac{1}{T} \int [I_p I [\cos \varphi - \cos (2\omega t - \varphi) \frac{dM}{d\theta}]] d\omega t \\&= I_p I \cos \varphi \frac{dM}{d\theta} \\&= \frac{V}{R} I \cos \varphi \frac{dM}{d\theta} \\&= \frac{P}{R} \frac{dM}{d\theta}\end{aligned}$$

$$T_d(\text{average}) \propto P$$

Errors in Electrodynamometer Wattmeter

1. Pressure Coil Inductance – The pressure coil of the Electrodynamometer has some inductance. Because of the inductance, the current of the pressure coils lags behind the voltage. Thus, the power factor of the wattmeter becomes lagging, and the meter reads high reading.

2. Pressure Coil Capacitance – The pressure coil has capacitances along with the inductance. This capacitance increases the power factor of the instrument. Hence causes the error in the reading.

3. Error due to Mutual Inductance Effect – The mutual inductance between the pressure and current coil produces an error.

4. Eddy Current Error – The eddy current induced in the coil creates its own magnetic field. This field affects the main current flows through the coil. Thus, the error occurs in the reading.

5. Stray Magnetic Field – The stray magnetic field disturbs the main magnetic field of the Electrodynamic Wattmeter. Thus, affect their reading.

6. Temperature Error – The variation in temperature will change the resistance of the pressure coil. The movement of the spring, which provides the controlling torque also affected because of the temperature change. Thereby, the error occurs in the reading.

Advantages of Electrodynamometer Type Wattmeter :

- A high degree of accuracy in the readings can be obtained.
- The scale of the instrument is uniform.
- Can be used in both ac and dc circuits.
- Due to the good accuracy of the instrument, it can be used for calibration.

Disadvantages of Dynamometer Type Wattmeter

1. The instrument is expensive, but the high accuracy obtained compensates this disadvantage.
2. Its accuracy is affected by the external magnetic fields, hence it must be screened.
3. At low power factors, the inductance of the pressure coil (P.C) introduces a serious error.

Low Power Factor Wattmeter -

A low power factor (LPF) wattmeter is an instrument used to measure power in low power factor circuits. This type of wattmeters is employed for power measurement in circuits whose power factor is less than 0.5.

- Generally, wattmeters are used for measuring power in a circuit. But, the power measurement using normal electrodynamic wattmeter in a circuit operating at low factors causes inaccurate in the readings due to the following reasons,
- When the ordinary wattmeter is connected to a low power factor circuit. Even though at full excitation of current and voltage coil, the deflecting torque produced on the moving coil is very small.
- Wattmeter operating at low factors introduces large errors due to voltage coil inductance.

Deflecting Torque

The deflecting of electro-dynamometer wattmeter is proportional to the load power in DC as well as AC circuit.

$$\text{Deflecting Torque}(\tau_d) \propto I_1 I_2$$

Since the current I_2 is proportional to load voltage V . Thus,

$$\text{Deflecting Torque}(\tau_d) \propto I_1 V \propto \text{Load Power}$$

$$u = V_m \sin \theta$$

$$i = I_m \sin(\theta - \varphi)$$

Instantaneous deflecting torque $\propto u i$

Due to inertia of moving system, the pointer cannot follow the rapid changes in the instantaneous power. Hence the wattmeter indicates the average power.

\therefore *Average Deflecting torque* (τ_d) \propto *Average of vi over one cycle*

$$\tau_d \propto \frac{1}{2\pi} \int_0^{2\pi} V_m I_m \sin \theta \sin(\theta - \varphi) d\theta \propto \frac{V_m I_m}{2} \cos \varphi \propto VI \cos \varphi$$

Where, V and I are RMS values

$$\tau_d \propto VI \cos \varphi \propto \text{Load Power}$$

Since the controlling torque in the wattmeter is provided by spring.
Thus,

$$\tau_c \propto \theta$$

Under steady state condition,

$$\tau_d = \tau_c$$

Therefore,

$$\theta \propto \text{Load Power}$$

Hence the electro-dynamometer wattmeter has uniform scale.

Single phase energy meter

- Induction type instruments are most commonly used as energymeter. It is an integrating instrument which measures quantity of electricity

Working principle:

- In all induction meters, we have two fluxes which are produced by two different alternating currents on a metallic disc. Due to alternating fluxes, there is an induced emf, the emf produced at one point interacts with the alternating current of the other side resulting in the production of torque.
- Similarly, the emf produced at the point two interacts with the alternating current at point one, resulting in the production of torque again but in opposite direction. Hence due to these two torques which are in different directions, the metallic disc moves. This is the basic principle of working of an **induction type meters**.

Single phase energy meter

- Single phase induction type energy meter is also popularly known as *watt-hour meter*. In the energymeter, there is no controlling torque and thus due to driving torque only a continuous rotation of the disc is produced. To have constant speed of rotation, braking magnet is provided.
- Construction:
 1. Driving system
 2. Moving system
 3. Braking system
 4. Registering system

Single phase energy meter

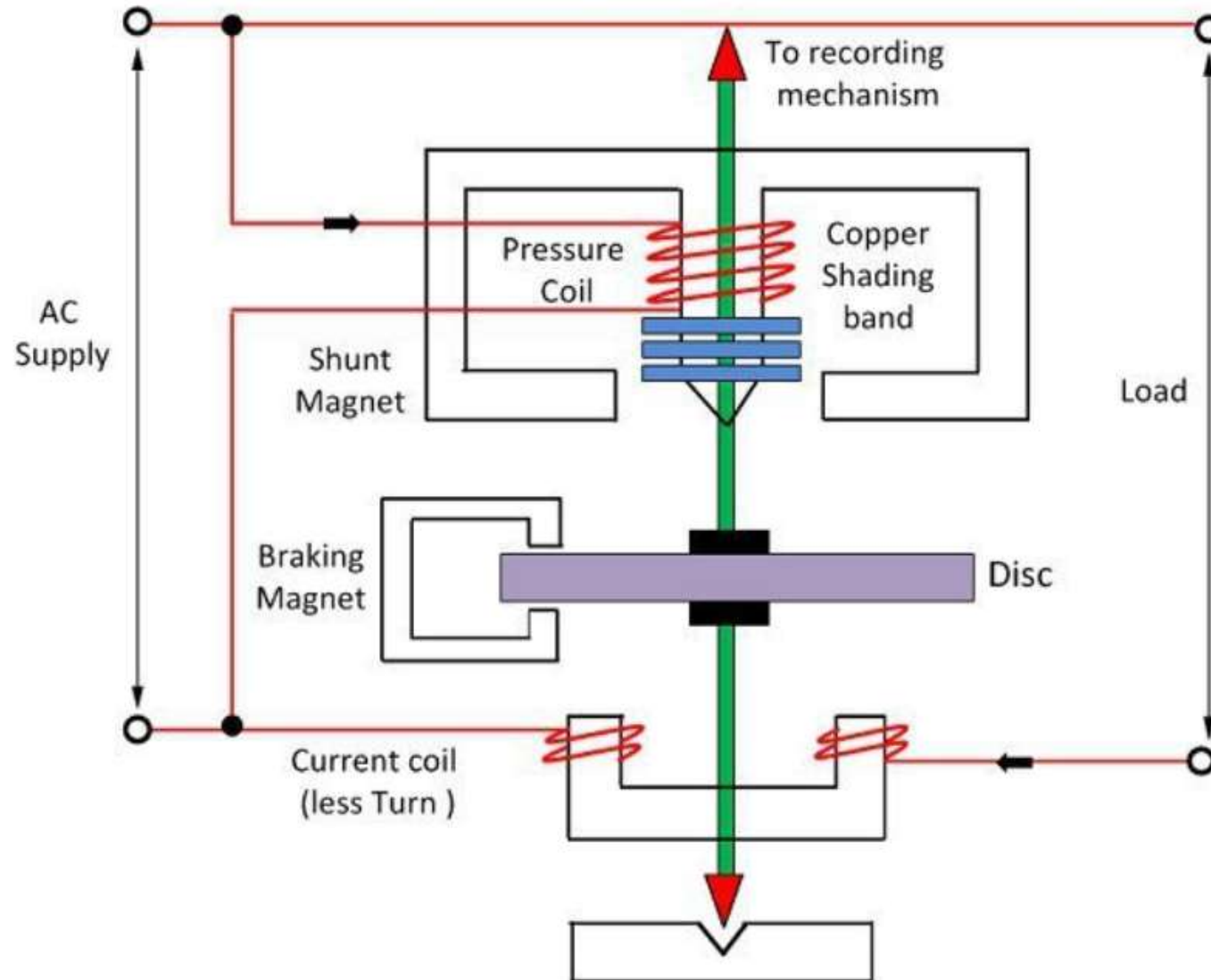

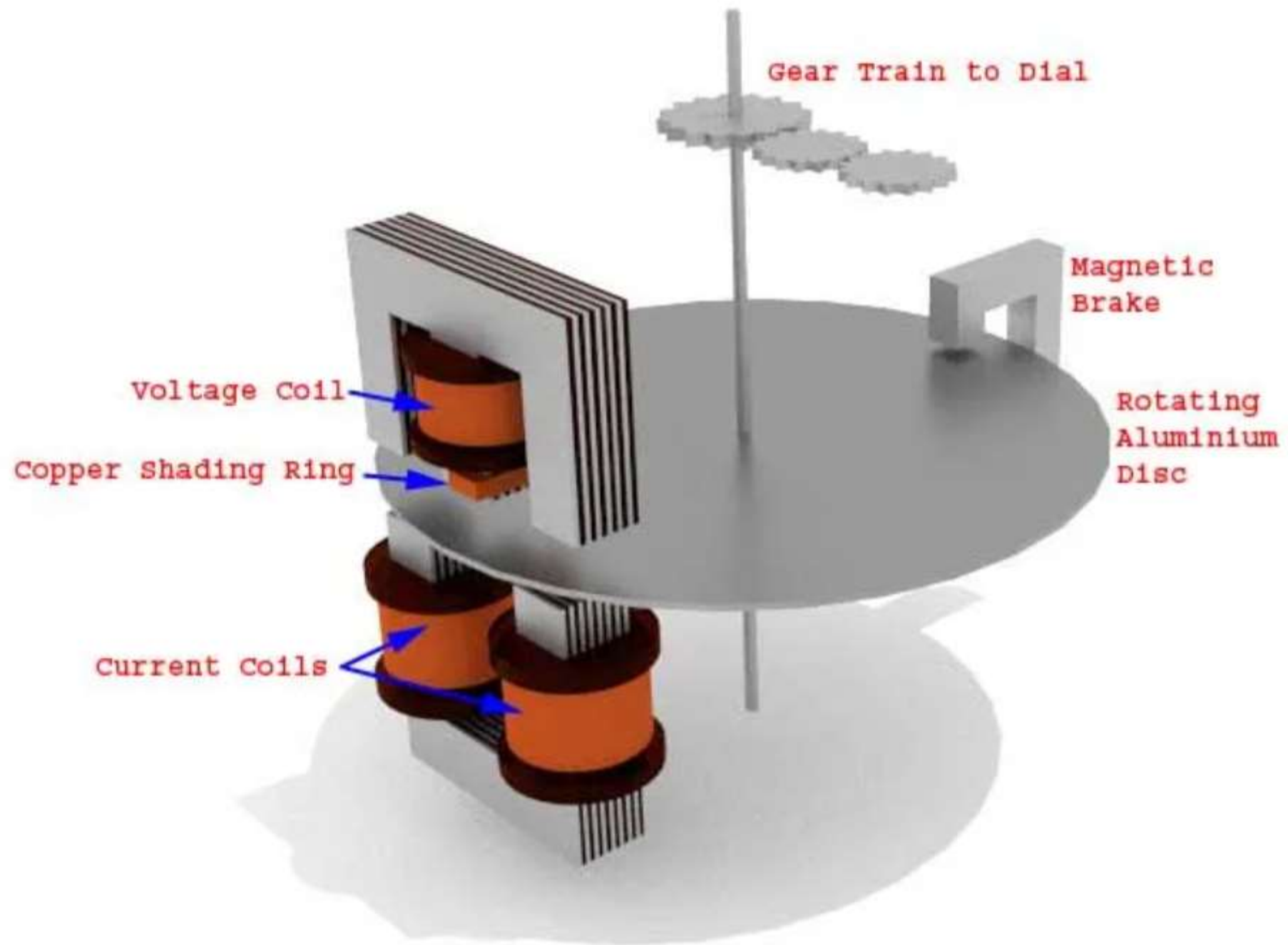



kW - h

00000

KILOWATT-HOUR METER



SINGLE PHASE 220V
50Hz 10A 600r/kWh



Single phase energy meter

The electromagnet is the main component of the **driving system**. It is the temporary magnet which is excited by the current flow through their coil. The core of the electromagnet is made up of silicon steel lamination. The driving system has two electromagnets. The upper one is called the shunt electromagnet, and the lower one is called series electromagnet.

The series electromagnet is excited by the load current flow through the current coil. The coil of the shunt electromagnet is directly connected with the supply and hence carry the current proportional to the shunt voltage. This coil is called the pressure coil.

The centre limb of the magnet has the copper band. These bands are adjustable. The main function of the copper band is to align the flux produced by the shunt magnet in such a way that it is exactly perpendicular to the supplied voltage.

Single phase energy meter

The **moving system** is the aluminium disc mounted on the shaft of the alloy. The disc is placed in the air gap of the two electromagnets. The eddy current is induced in the disc because of the change of the magnetic field. This eddy current is cut by the magnetic flux. The interaction of the flux and the disc induces the deflecting torque.

When the devices consume power, the aluminium disc starts rotating, and after some number of rotations, the disc displays the unit used by the load. The number of rotations of the disc is counted at particular interval of time. The disc measured the power consumption in kilowatt hours.

Single phase energy meter

Braking system

The permanent magnet is used for reducing the rotation of the aluminium disc. The aluminium disc induces the eddy current because of their rotation. The eddy current cut the magnetic flux of the permanent magnet and hence produces the braking torque.

This braking torque opposes the movement of the disc, thus reduces their speed. The permanent magnet is adjustable due to which the braking torque is also adjusted by shifting the magnet to the other radial position.

Single phase energy meter

Registration (Counting Mechanism)

The main function of the registration or counting mechanism is to record the number of rotations of the aluminium disc. Their rotation is directly proportional to the energy consumed by the loads in the kilowatt hour.

The rotation of the disc is transmitted to the pointers of the different dial for recording the different readings. The reading in kWh is obtained by multiply the number of rotations of the disc with the meter constant.

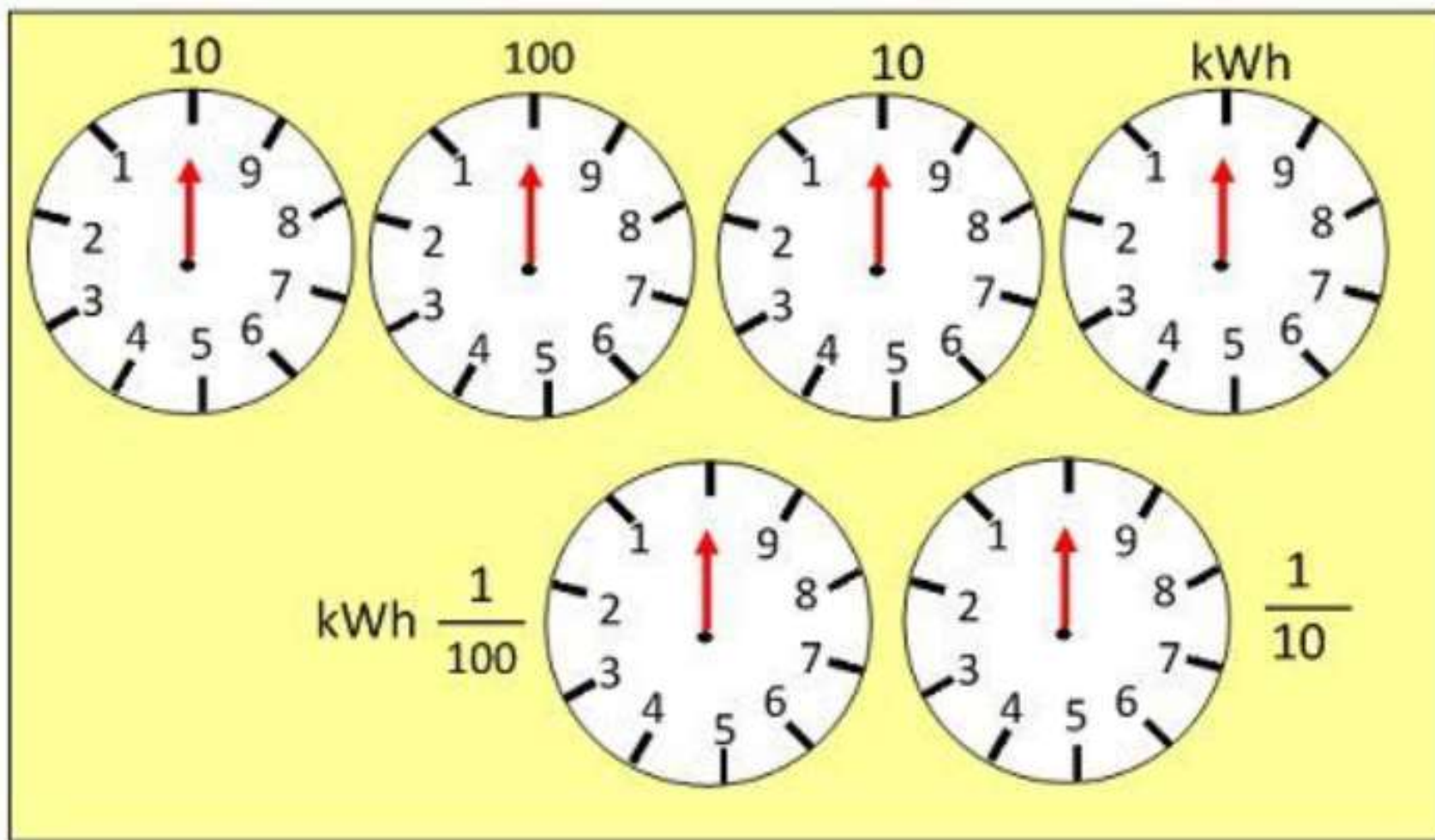

Pointer Type of Register

Torque equation of energymeter

Let V = supply voltage

I_2 - current through pressure coil proportional to V

Φ_2 – flux produced by I_2

I_1 - current through current coil (ie) load

Φ_1 – flux produced by I_1

I_2 lags V by 90° as pressure coil is highly inductive and copper shading band. Φ_2 and I_2 are inphase

I_1 lags V by Φ , Where Φ is decided by load connected. Φ_1 and I_1 are inphase

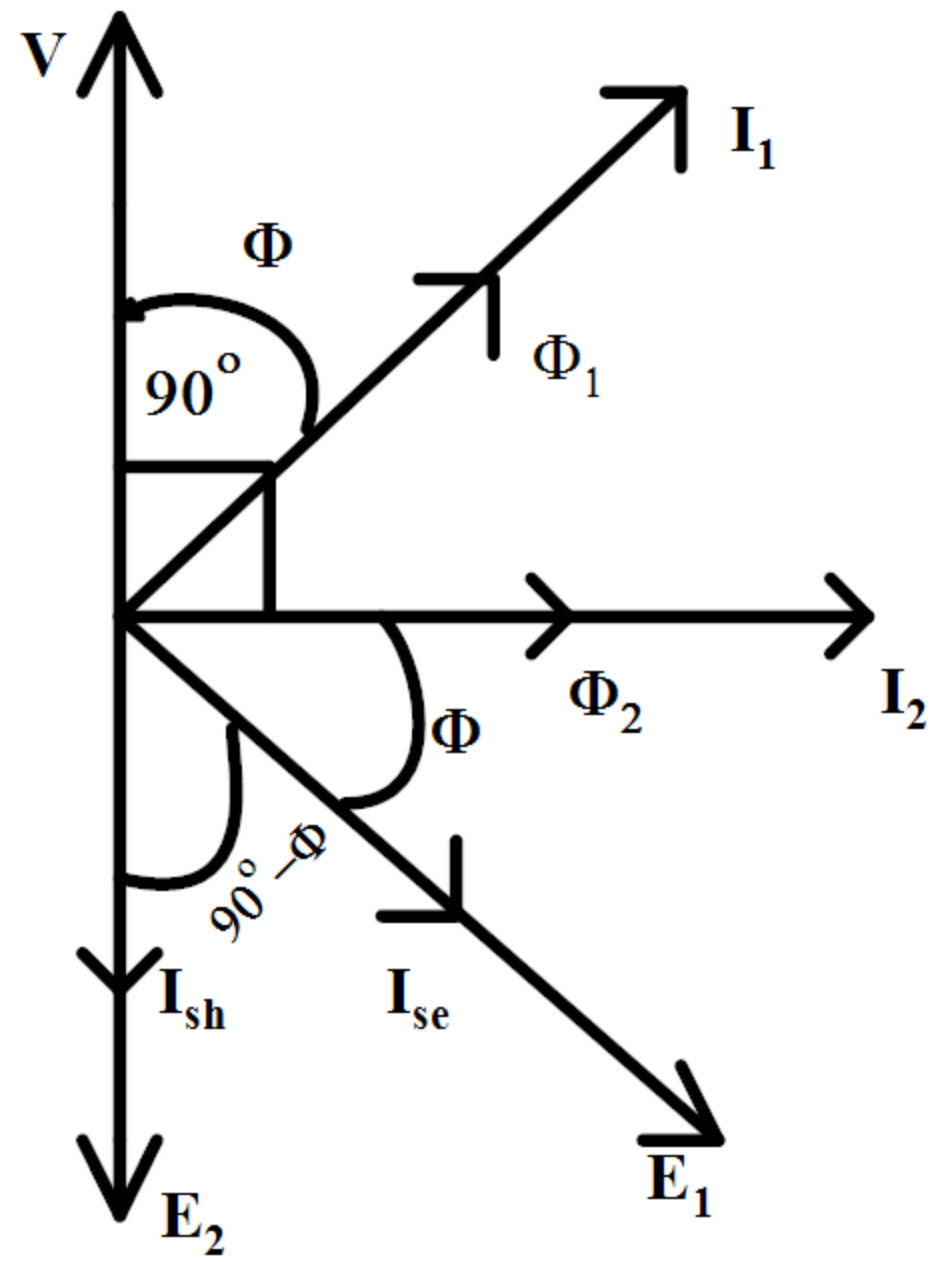

$E_1 =$ induced emf in disc due to Φ_1

$E_2 =$ induced emf in disc due to Φ_2

$I_{sh} =$ Eddy current due to E_1

$I_{se} =$ Eddy current due to E_2

Induced emf lags the respective flux producing it by 90° . Eddy currents are in phase with the induced emf producing them.

Interaction between Φ_1 and I_{sh} which produces torque T_1

Interaction between Φ_2 and I_{se} which produced torque T_2 .

T_2 is opposite direction to T_1

Hence net deflecting torque is,

$$T_d \propto T_2 - T_1$$

$$\propto \phi_2 I_{se} \cos(\phi_2 \wedge I_{se}) - \phi_1 I_{sh} \cos(\phi_1 \wedge I_{sh})$$

$$\phi_2 \wedge I_{se} = \phi ; \quad \phi_1 \wedge I_{sh} = 180 - \phi$$

$$T_d \propto \phi_2 I_{se} \cos(\phi) - \phi_1 I_{sh} \cos(180 - \phi)$$

$$\cos(180 - \phi) = -\cos(\phi)$$

$$\text{Therefore, } T_d \propto \phi_2 I_{se} \cos(\phi) + \phi_1 I_{sh} \cos(\phi)$$

$$\text{But, } \phi_2 \propto I_2 \propto V ; \quad I_{se} \propto E_1 \propto I_1 ; \quad \phi_1 \propto I_1 ; \quad I_{sh} \propto E_2 \propto I_2 \propto V$$

$$T_d = K_1 V I_1 \cos(\phi) + K_2 V I_1 \cos(\phi)$$

$$T_d = (K_1 + K_2) V I_1 \cos(\phi)$$

$$T_d \propto V I_1 \cos(\phi) \text{ (ie) the power consumed by the load.}$$

Braking torque is proportional to speed N with which the disc rotates.

$$T_b \propto N$$

At constant speed,

$$T_d = T_b$$

$$N \propto V I_1 \cos(\phi)$$

Multiply both sides by t

$$N t \propto V I_1 \cos(\phi) t \propto P t$$

Number of revolutions in time $t \propto$ energy supplied

Thus, by counting the number of revolutions electrical energy consumed can be measured.

Adjustments in energy meter

1. Main speed adjustment:

Speed of meter can be adjusted by changing the radius of the braking magnet.

2. Power factor adjustment:

Meter should correctly measure for all power factor condition of the load. I_2 lags supply voltage by 90° . But iron loss and resistance of winding will not allow I_2 to lag supply voltage by 90° . Adjustment can be done by Cu shading bands.

3. Friction adjustment:

In spite of proper design of the bearing and registering mechanism, there exist some friction. This can be compensated by metallic loop or strips provided between the central limb of shunt magnet and Disc.

4. Creep adjustment:

Without any current through Current Coil disc rotates due to the supply voltage exciting its pressure coil. This is called creeping. This is because of overfriction compensation. To eliminate this two holes are drilled in the disc 180° opposite to each other.

Advantages of Induction Type Energy Meter

1. Cheap in cost.
2. Simple construction.
3. Low maintenance.
4. More accurate on a wide range of loads.
5. Good damping.
6. The moving element has no electrical contact with the circuit

Disadvantages of Induction Type Energy Meter

1. It can be used for AC circuits only.
2. They have non-linear scales.
3. They consume a considerable amount of power.

Three phase energy meter

- 3 ϕ , 4 wire system -> measurement of energy is carried out by -> 3 ϕ energy meter
- 3 ϕ , 3 wire system -> measurement of energy is carried out by -> 2 element energy meter (similar to 2 wattmeter for power measurement if 3 ϕ , 3 wire system)
- Meters are classified as
 - Three element energy meter
 - Two element energy meter

Three element energy meter

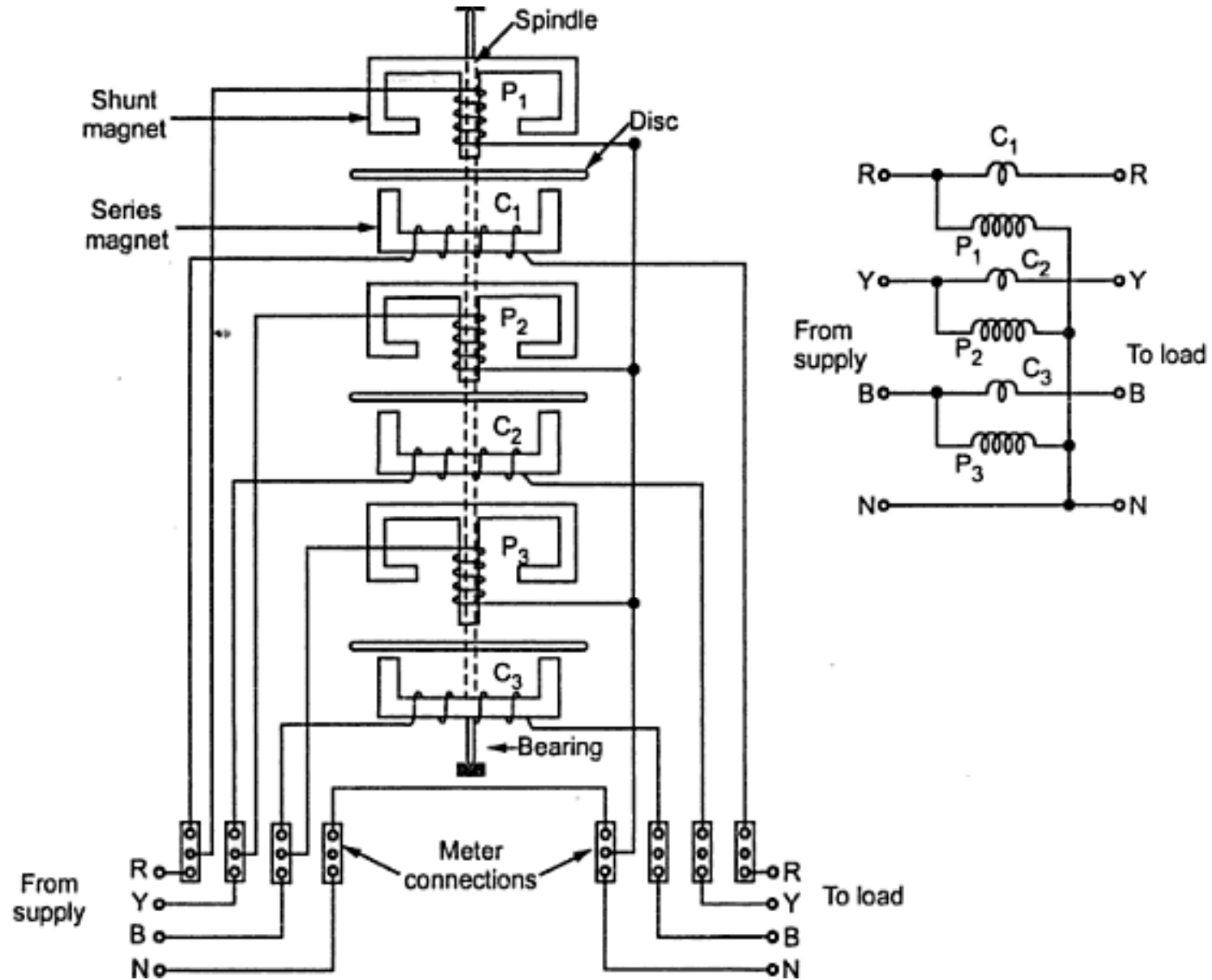

- Meter consists of three elements.
- $P_1, P_2, P_3 \rightarrow$ pressure coil, $C_1, C_2, C_3 \rightarrow$ current coil.
- All elements are connected vertically in common case and have a common spindle, gearing and registering mechanism. .
- Coils are connected such that the net torque produced is sum of the torques due to all the three elements.
- Three phase elements is always cheaper than three units of single phase energy meter.
- Due to interactions between eddy currents produced by one element with flux produced by another element, errors may occur.

Two element energy meter

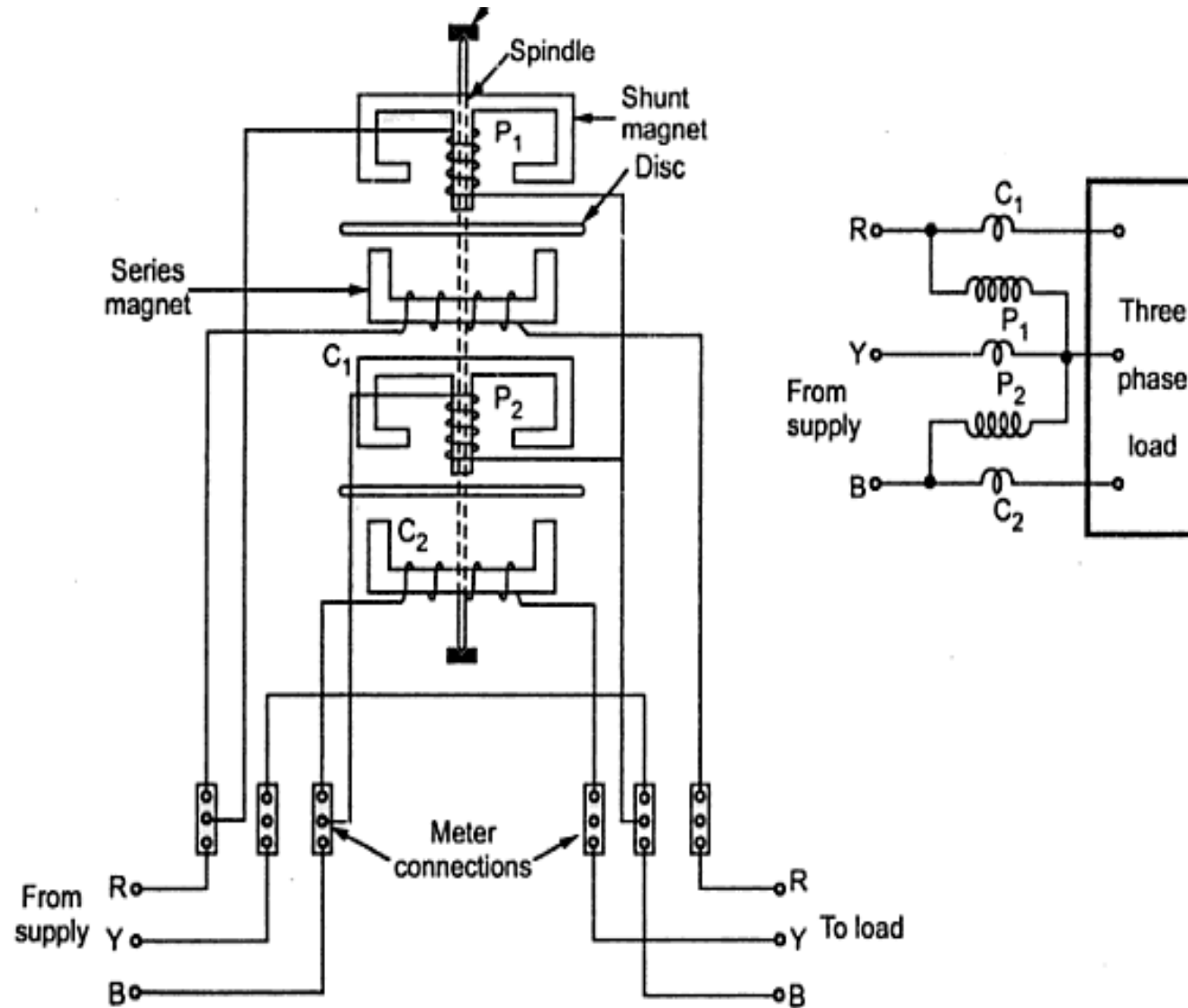

In the energy meter testing, the actual registration of energy (by the meter) is verified against known standard values at various loads and power factors. The energy meter testing helps in providing suitable adjustments in the meter so as to reduce errors. The actual registration is verified under the following test conditions.

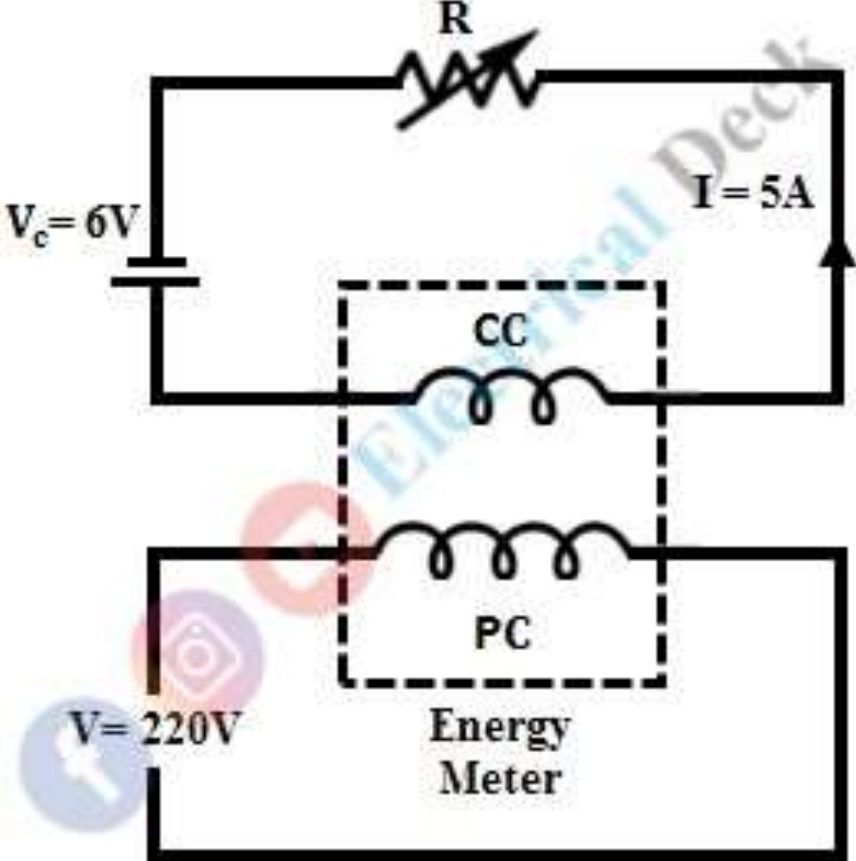

Trivector Meter - Definition & Working

Trivector meter is used to measure the kVAh and kVA of maximum demand. It consists of two meters whose discs are coupled with a special kind of summator through a complicated gearing system. Among the two meters, one is an energy (kilowatt-hour) meter and the other is a reactive kilo volt ampere-hour meter.

The coupling system adds the speeds of the meters vectorially and hence the speed of the summator will be proportional to the kVAh. So, the meter registers the accurate value of kVAh at any power factor. This complicated gearing system consists of five typical gear systems. They are as follows,

Maximum Demand meter

Maximum Demand meter is used for monitoring thermal loading in Power Distribution systems, Networks, Machines etc. It indicates maximum loading current over a period. Short-period current peaks are not registered but long overloads are registered. In the Maximum Demand meter the measuring current flows through the bimetal spiral which is temperature sensitive. The free end of the spiral is connected to a black measuring pointer. The moving system is activated by heat generated by the current flowing through the spiral. The instrument is provided with an additional red slave pointer with a higher friction, which makes it to remain at its maximum position, which determines the maximum average loading current. The high torque of metallic movement drags the red pointer along with the black pointer. The red pointer remains stationary at the maximum value reached. This can be reset by rotating the knob provided on front facia. To prevent false indication due to fluctuations in ambient temperature, an additional bimetallic spiral is wound in opposite direction, which is mounted on the same spindle to compensate variation in temperature from 10 to +55 degrees Centigrade. Frequently there is a need to measure instantaneous current simultaneously & hence moving iron movement having the same range is incorporated in the same meter.

UNIT-IV

DC & AC Bridges

MEASUREMENT OF MEDIUM RESISTANCE (1Ω - $100K\Omega$)

A bridge circuit always works on the principle of null detection, i.e. we vary a parameter until the detector shows zero and then use a mathematical relation to determine the unknown in terms of varying parameter and other constants. Here also the standard resistance, S is varied in order to obtain null deflection in the galvanometer. This null deflection implies no current from point c to d , which implies that potential of point c and d is same. Hence

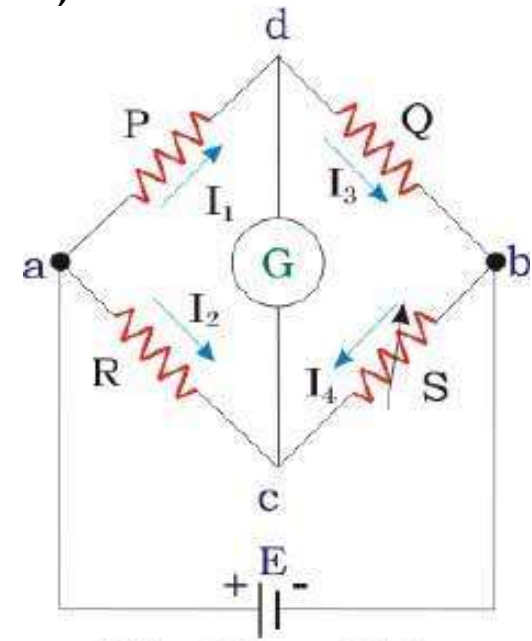

Wheatstone Bridge

$$I_1 P = I_2 R \dots\dots (4)$$

$$\text{Also, } I_1 = I_3 = \frac{E}{(P + Q)} \text{ and } I_2 = I_4 = \frac{E}{(R + S)}$$

Combining the above two equations we get the famous equation –

$$R = \frac{P}{Q} S$$

Carey Foster Bridge

The Carey foster bridge principle is simple and similar to Wheatstone's bridge working principle.

It works on the principle of null detection. That means the ratios of the resistances will be equal and the galvanometer records zero where there is no current flow.

Consider I_1 be the distance from the left side where the bridge is balanced. Interchange the resistances R and S while the bridge gets balanced by sliding the contact with a distance of I_2 .

The switch is used to interchange the resistances R and S while testing. The galvanometer records zero when the bridge is balanced. The first bridge balance equation is,

$$P/Q = (R + I_1 r) / [(S + (L - I_1) r)]$$

Where r = resistance/unit length of the slide wire.

Now interchange the resistances R and S . Then the balanced equation for the bridge circuit is given as,

For the first balance equation, we get,

$$P/Q + 1 = [(R + I_1 r + S + (L - I_1) r) / [S + (L - I_1) r]] \dots\dots \text{Eq (1)}$$

$$P/Q = (R + S + I_1 r) / (S + (L - I_1) r)$$

We get a second bridge balance equation as

$$P/Q + 1 = [(S + I_2 r + R + (L - I_2) r) / [R + (L - I_2) r]] \dots\dots \text{Eq (2)}$$

$$P/Q + 1 = (S + R + I_2 r) / (R + (L - I_2) r)$$

From the above equations (1) and (2)

$$S + (L - I_1) r = R + (L - I_1) r$$

$$S - R = (I_1 - I_2)$$

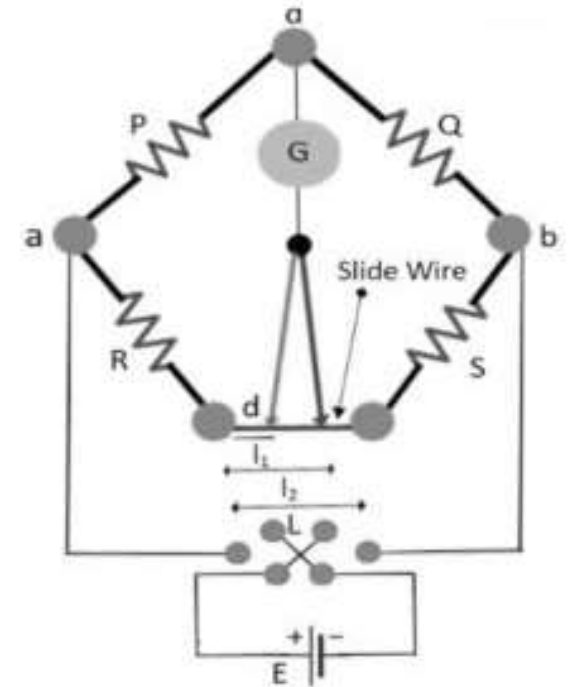

KELVIN'S DOUBLE BRIDGE

Kelvin's double bridge is a modification of simple Wheatstone bridge. Figure below shows the circuit diagram of Kelvin's double bridge.

$$E_{ad} = E_{amc}$$

$$\text{Or, } \left\{ \frac{P}{P+Q} \right\} E_{ab} = I \left[R + \frac{p}{p+q} \left\{ \frac{r(p+q)}{p+q+r} \right\} \right] \dots\dots (1)$$

$$\text{Where, } E_{ab} = I \left[R + S + \frac{p}{p+q} \left\{ \frac{r(p+q)}{p+q+r} \right\} \right] \dots\dots (2)$$

Putting eqn 2 in 1 and solving and using $P/Q = p/q$, we get-

$$R = \frac{P}{Q} S$$

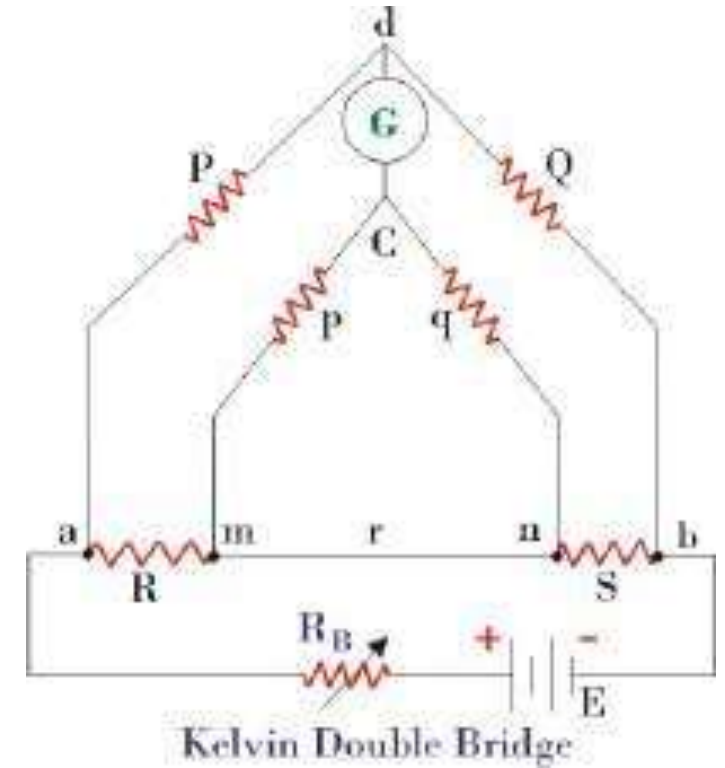

Following are few methods used for measurement of high resistance values-

- Loss of Charge Method
 - Megger
 - Megohm bridge Method
 - Direct Deflection Method
- LOSS OF CHARGE METHOD

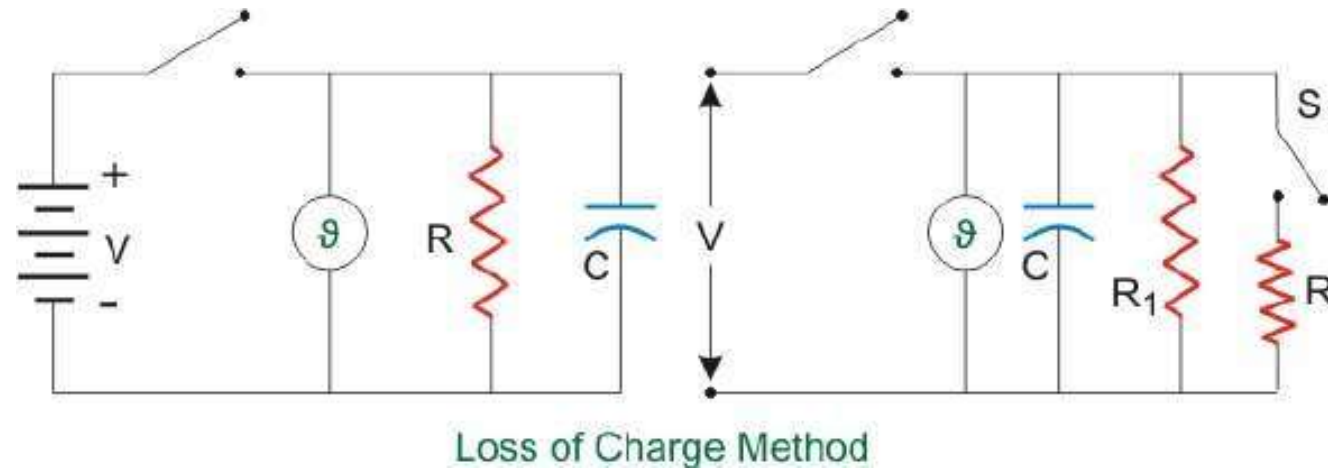

Maxwell's inductance bridge

The choke for which R_1 and L_1 have to measure connected between the points 'A' and 'B'. In this method the unknown inductance is measured by comparing it with the standard inductance.

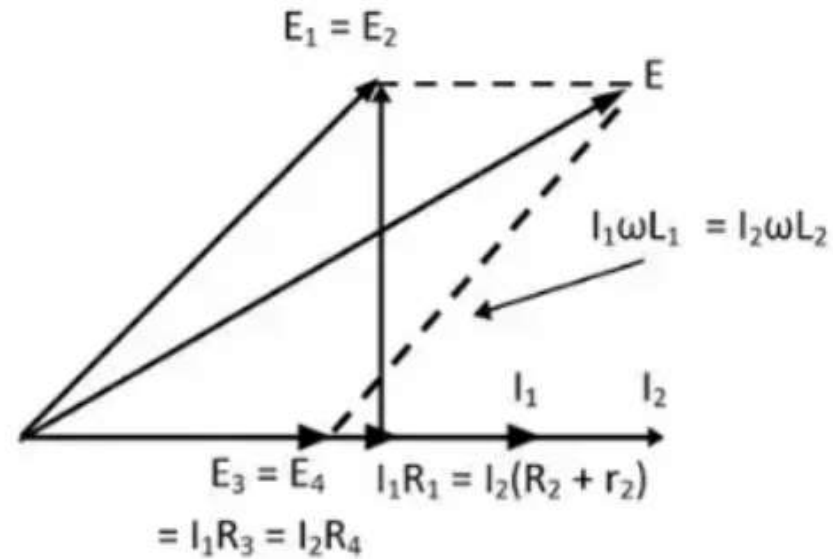
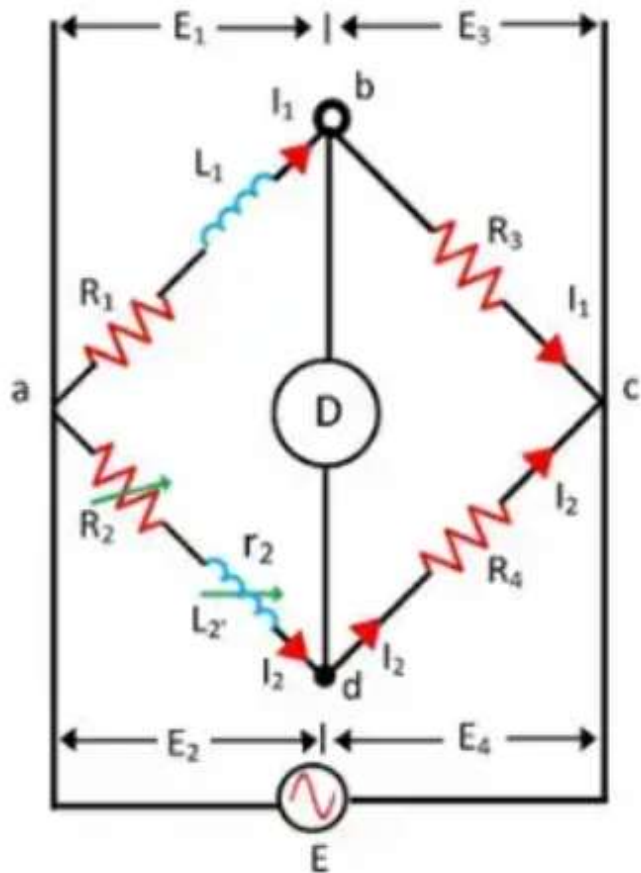

At balance condition, $\dot{Z}_1 \dot{Z}_4 = \dot{Z}_2 \dot{Z}_3$

$$(R_1 + jXL_1)R_4 = (R_2 + jXL_2)R_3$$

$$(R_1 + j\omega L_1)R_4 = (R_2 + j\omega L_2)R_3$$

$$R_1R_4 + j\omega L_1R_4 = R_2R_3 + j\omega L_2R_3$$

Comparing real part,

$$R_1R_4 = R_2R_3$$

$$\therefore R_1 = \frac{R_2R_3}{R_4}$$

Comparing the imaginary parts,

$$\omega L_1R_4 = \omega L_2R_3$$

$$L_1 = \frac{L_2R_3}{R_4}$$

$$\text{Q-factor of choke, } Q = \frac{\omega L_1}{R_1} = \frac{\omega L_2 R_3 R_4}{R_4 R_2 R_3}$$

$$Q = \frac{\omega L_2}{R_2}$$

Hay's bridge

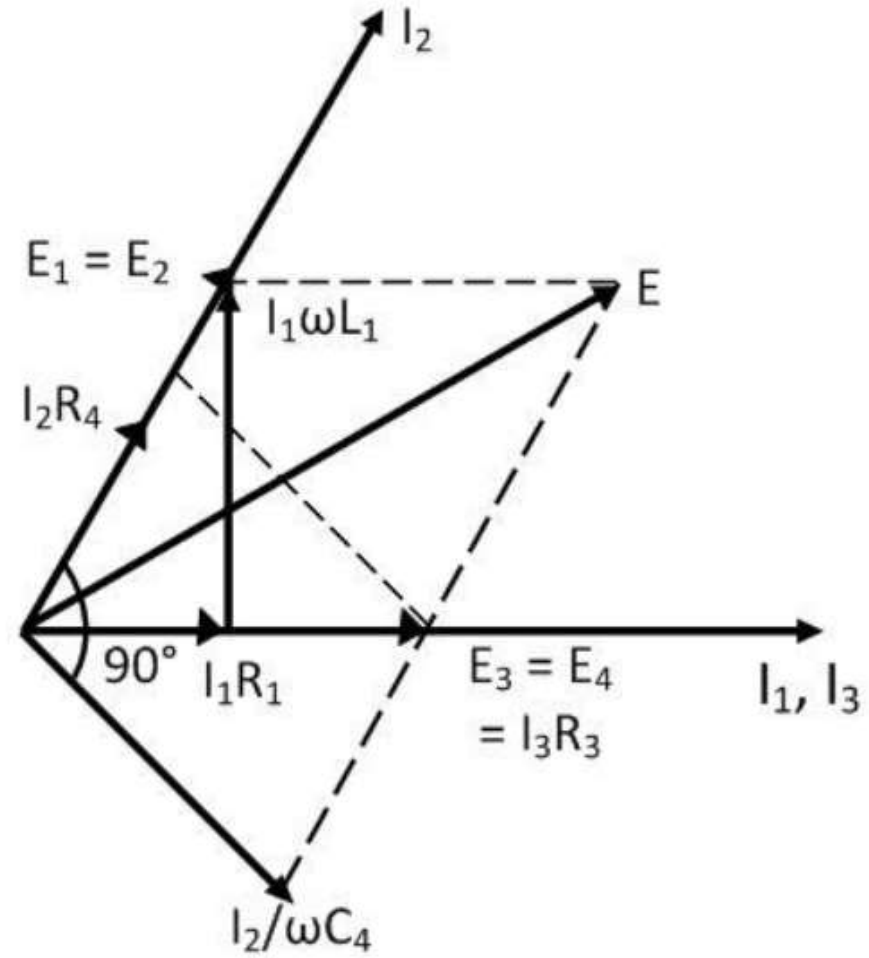
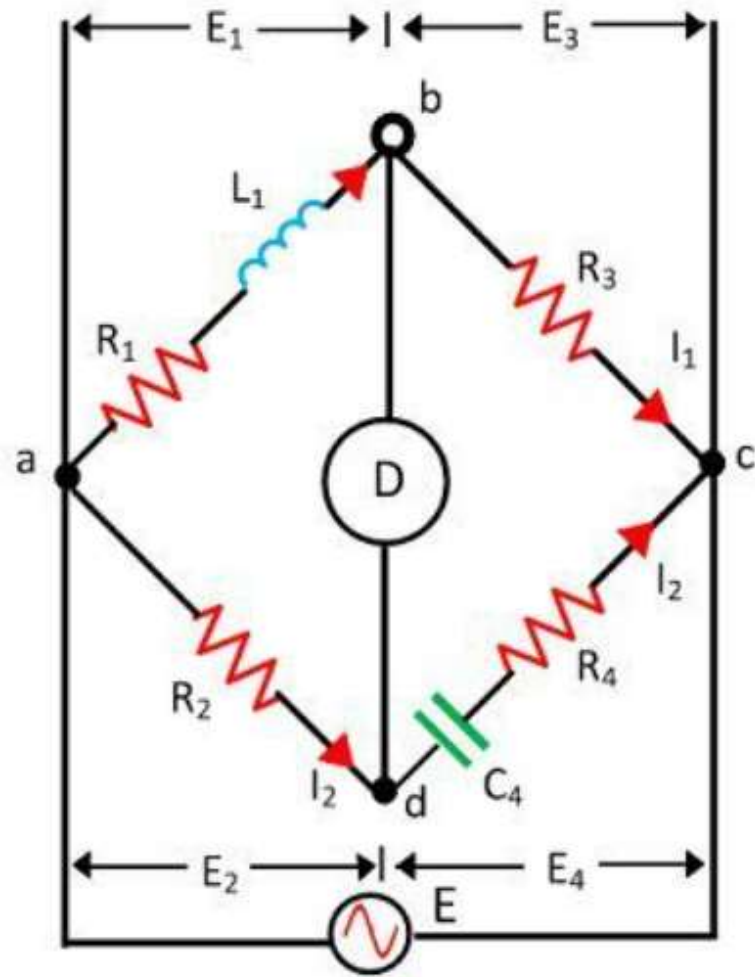

$$\triangleright \dot{E}_1 = I_1 R_1 + jI_1 X_1$$

$$\triangleright \dot{E} = \dot{E}_1 + \dot{E}_3$$

$$\triangleright \dot{E}_4 = \dot{I}_4 R_4 + \frac{I_4}{j\omega C_4}$$

$$\triangleright \dot{E}_3 = I_3 R_3$$

$$Z_4 = R_4 + \frac{1}{j\omega C_4} = \frac{1 + j\omega R_4 C_4}{j\omega C_4}$$

$$L_1 = \frac{C_4 R_2 R_3}{1 + \omega^2 L_1 C_4^2 R_4^2}$$

Substituting the value of L_1 in eqn. 2.14 , we have

$$R_1 = \frac{\omega^2 C_4^2 R_2 R_3 R_4}{1 + \omega^2 C_4^2 R_4^2}$$

$$Q = \frac{\omega L_1}{R_1} = \frac{\omega \times C_4 R_2 R_3}{1 + \omega^2 C_4^2 R_4^2} \times \frac{1 + \omega^2 C_4^2 R_4^2}{\omega^2 C_4^2 R_4 R_2 R_3}$$

$$Q = \frac{1}{\omega C_4 R_4}$$

Owen's bridge

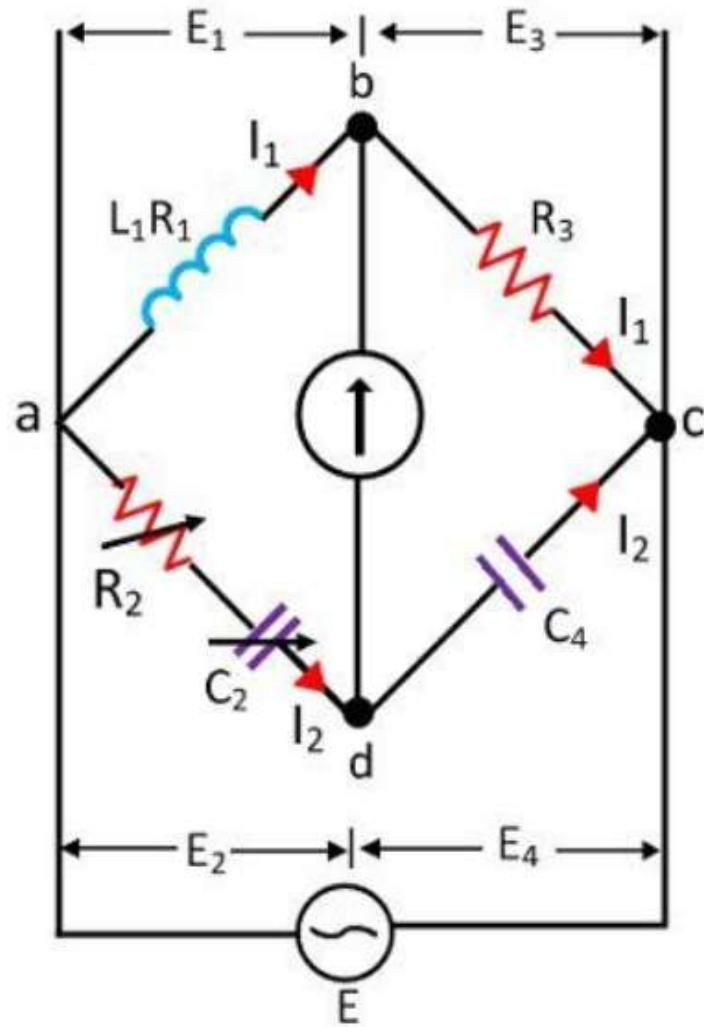

$$\triangleright \dot{E} = \dot{E}_1 + \dot{E}_3$$

$$\triangleright \dot{E}_2 = I_2 R_2 + \frac{I_2}{j\omega C_2}$$

Balance condition, $\dot{Z}_1 \dot{Z}_4 = \dot{Z}_2 \dot{Z}_3$

$$Z_2 = R_2 + \frac{1}{j\omega C_2} = \frac{j\omega C_2 R_2 + 1}{j\omega C_2}$$

$$\therefore (R_1 + j\omega L_1) \times \frac{1}{j\omega C_4} = \frac{(1 + j\omega R_2 C_2) \times R_3}{j\omega C_2}$$

$$C_2 (R_1 + j\omega L_1) = R_3 C_4 (1 + j\omega R_2 C_2)$$

$$R_1 C_2 + j\omega L_1 C_2 = R_3 C_4 + j\omega R_2 C_2 R_3 C_4$$

Comparing real terms,

$$R_1 C_2 = R_3 C_4$$

$$R_1 = \frac{R_3 C_4}{C_2}$$

Comparing imaginary terms,

$$\omega L_1 C_2 = \omega R_2 C_2 R_3 C_4$$

$$L_1 = R_2 R_3 C_4$$

$$Q\text{-factor} = \frac{\omega L_1}{R_1} = \frac{\omega R_2 R_3 C_4 C_2}{R_3 C_4}$$

$$Q = \omega R_2 C_2$$

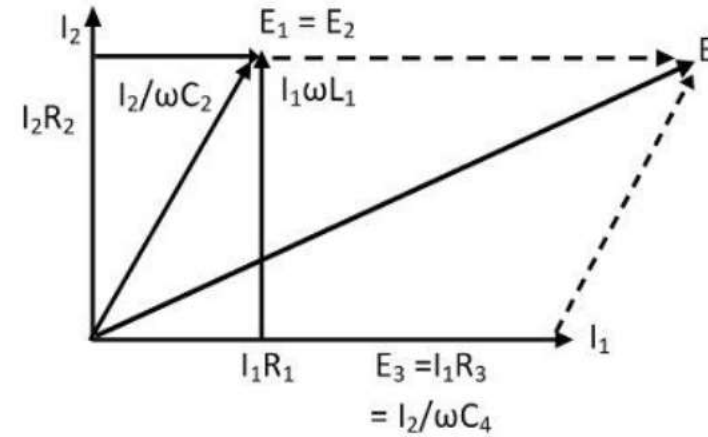

Anderson's bridge

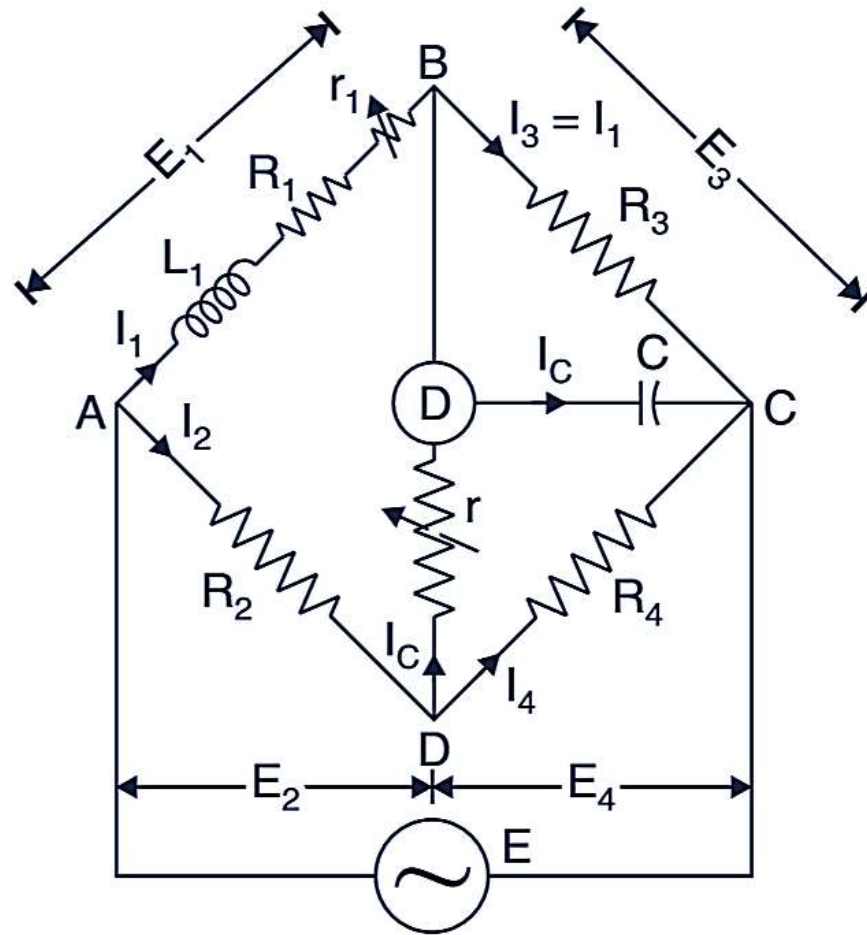

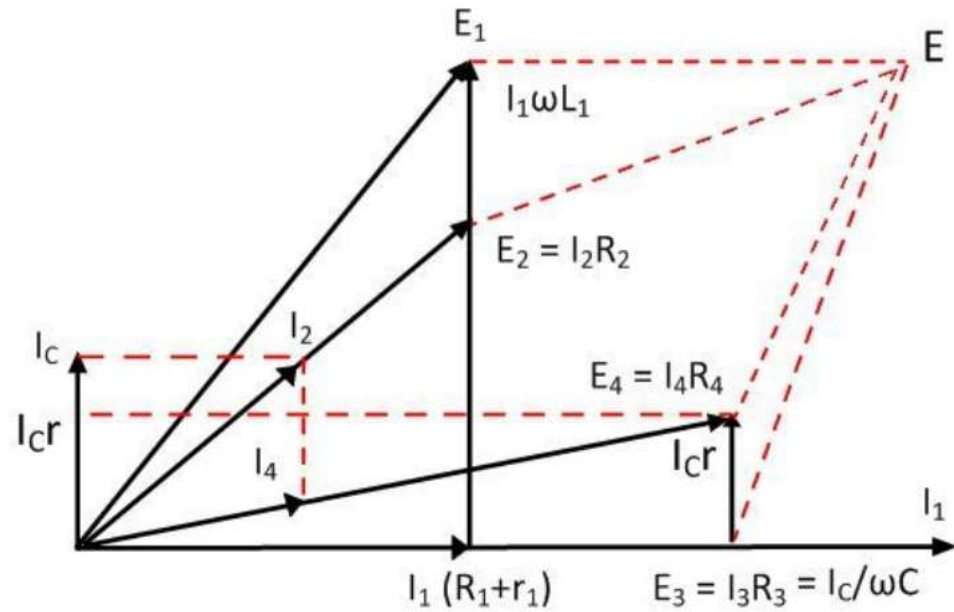

Comparing real term,

$$R_1^1 R_4 = R_2 R_3$$

$$(R_1 + r_1) R_4 = R_2 R_3$$

$$R_1 = \frac{R_2 R_3}{R_4} - r_1$$

Comparing the imaginary term,

$$\omega L_1 R_4 = \omega C R_2 R_3 (r + R_4) + \omega c r R_3 R_4$$

$$L_1 = \frac{R_2 R_3 C}{R_4} (r + R_4) + R_3 r C$$

$$L_1 = R_3 C \left[\frac{R_2}{R_4} (r + R_4) + r \right]$$

Measurement of capacitance and loss angle

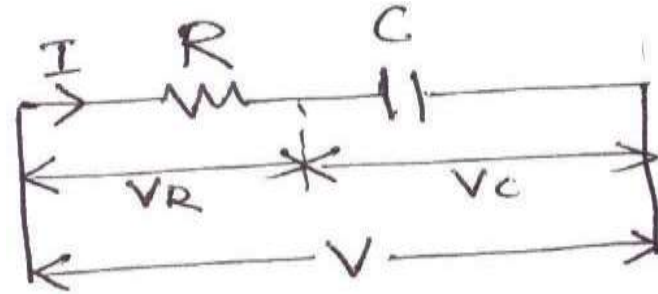
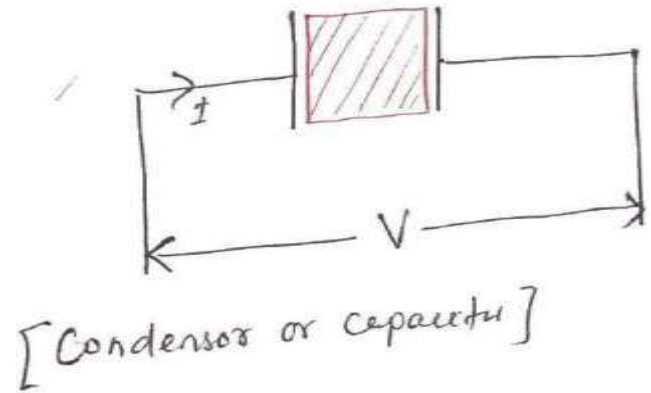

A dissipation factor is defined as 'tan δ '.

$$\therefore \tan \delta = \frac{IR}{IX_C} = \frac{R}{X_C} = \omega CR$$

$$D = \omega CR$$

$$D = \frac{1}{Q}$$

$$D = \tan \delta = \frac{\sin \delta}{\cos \delta} \cong \frac{\delta}{1} \quad \text{For small value of '}\delta\text{' in radians}$$

$$D \cong \delta \cong \text{Loss Angle} \quad (\delta \text{ must be in radian)}$$

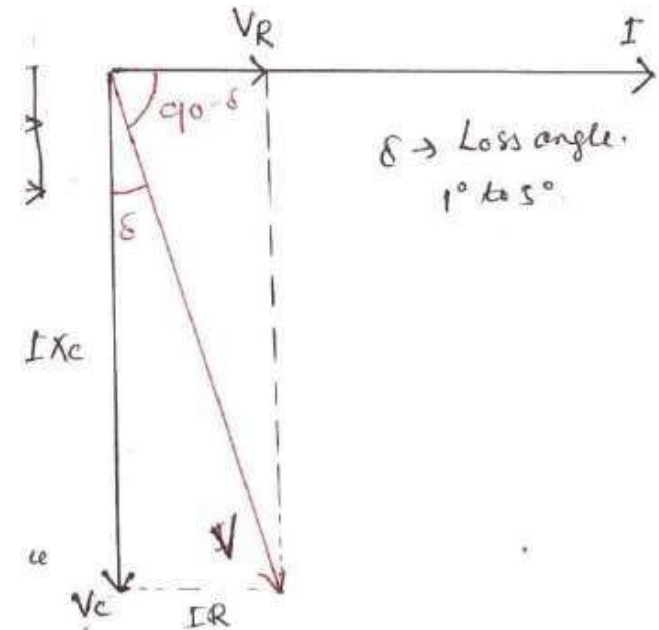

Desauty's Bridge

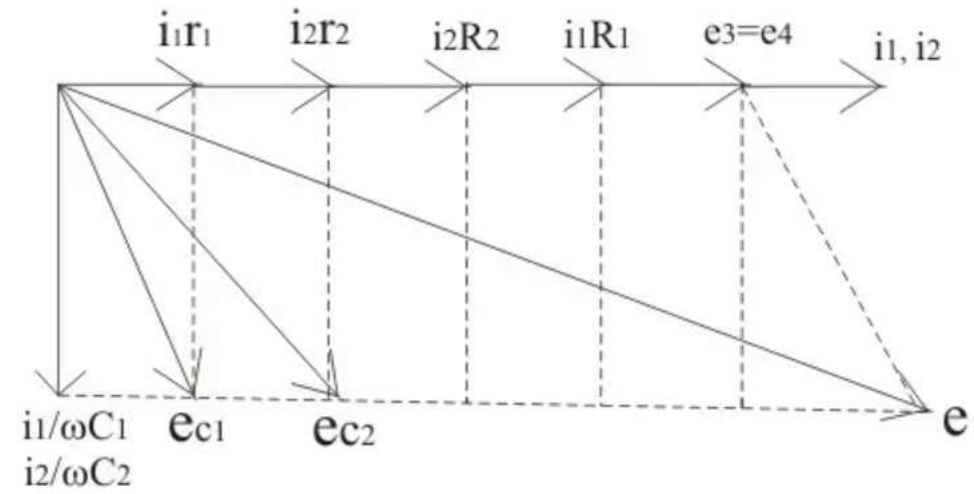
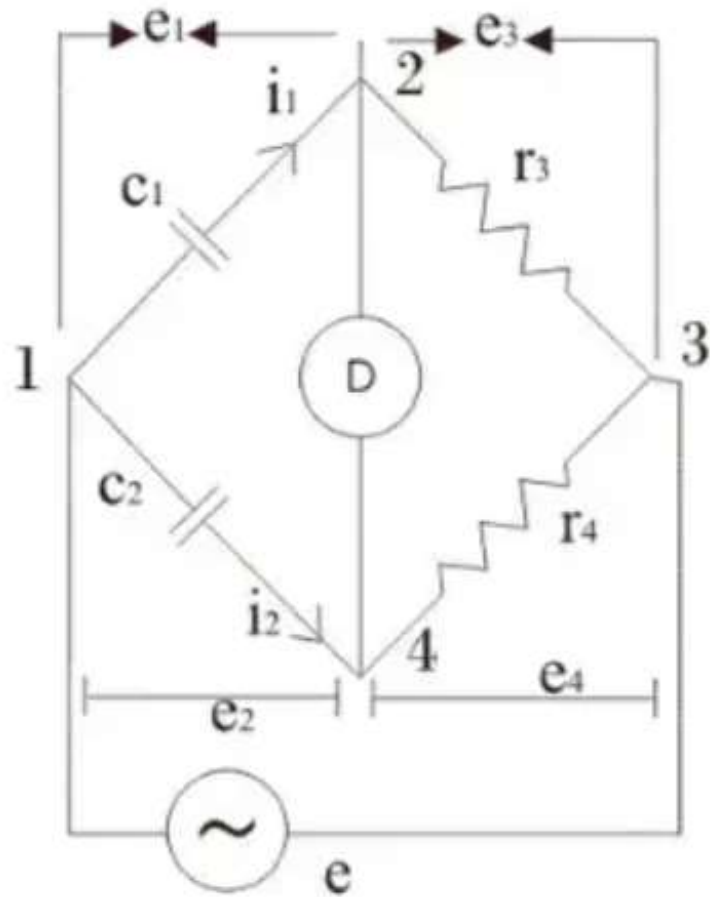

$C_1 =$ Unknown capacitance

At balance condition,

$$\frac{1}{j\omega C_1} \times R_4 = \frac{1}{j\omega C_2} \times R_3$$

$$\frac{R_4}{C_1} = \frac{R_3}{C_2}$$

$$\Rightarrow C_1 = \frac{R_4 C_2}{R_3}$$

Schering bridge

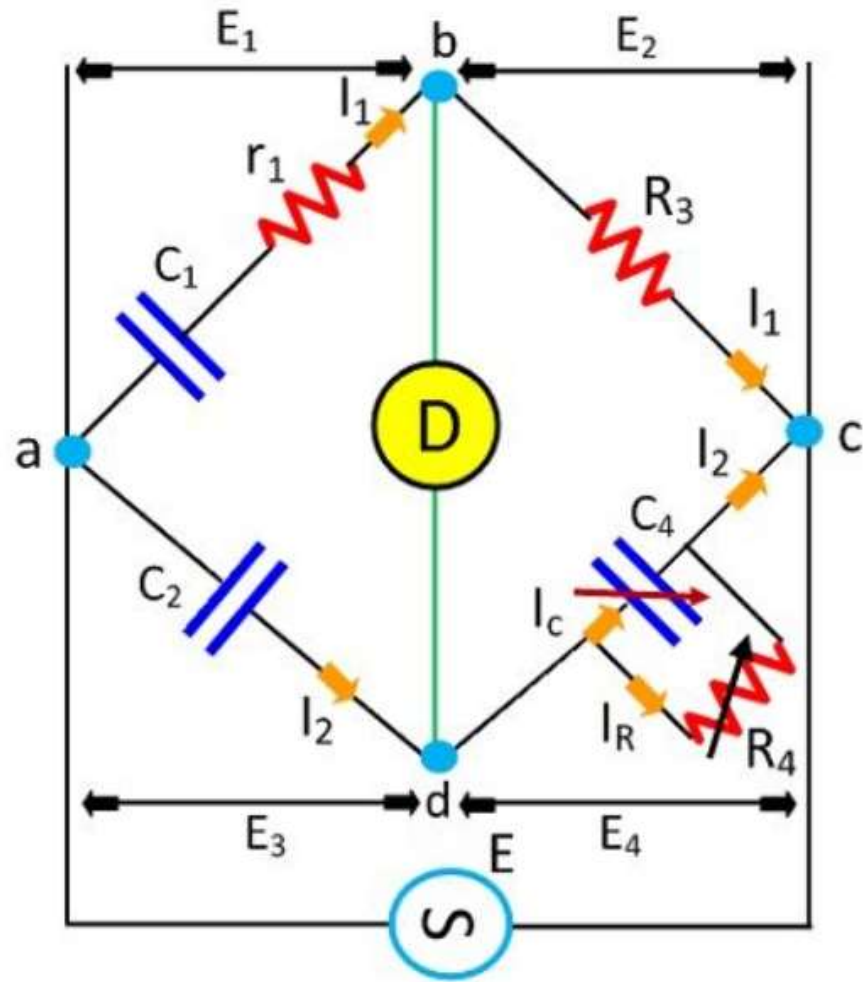

$$Z_1 = r_1 + \frac{1}{j\omega C_1} = \frac{j\omega C_1 r_1 + 1}{j\omega C_1}$$

$$Z_4 = \frac{R_4 \times \frac{1}{j\omega C_4}}{R_4 + \frac{1}{j\omega C_4}} = \frac{R_4}{1 + j\omega C_4 R_4}$$

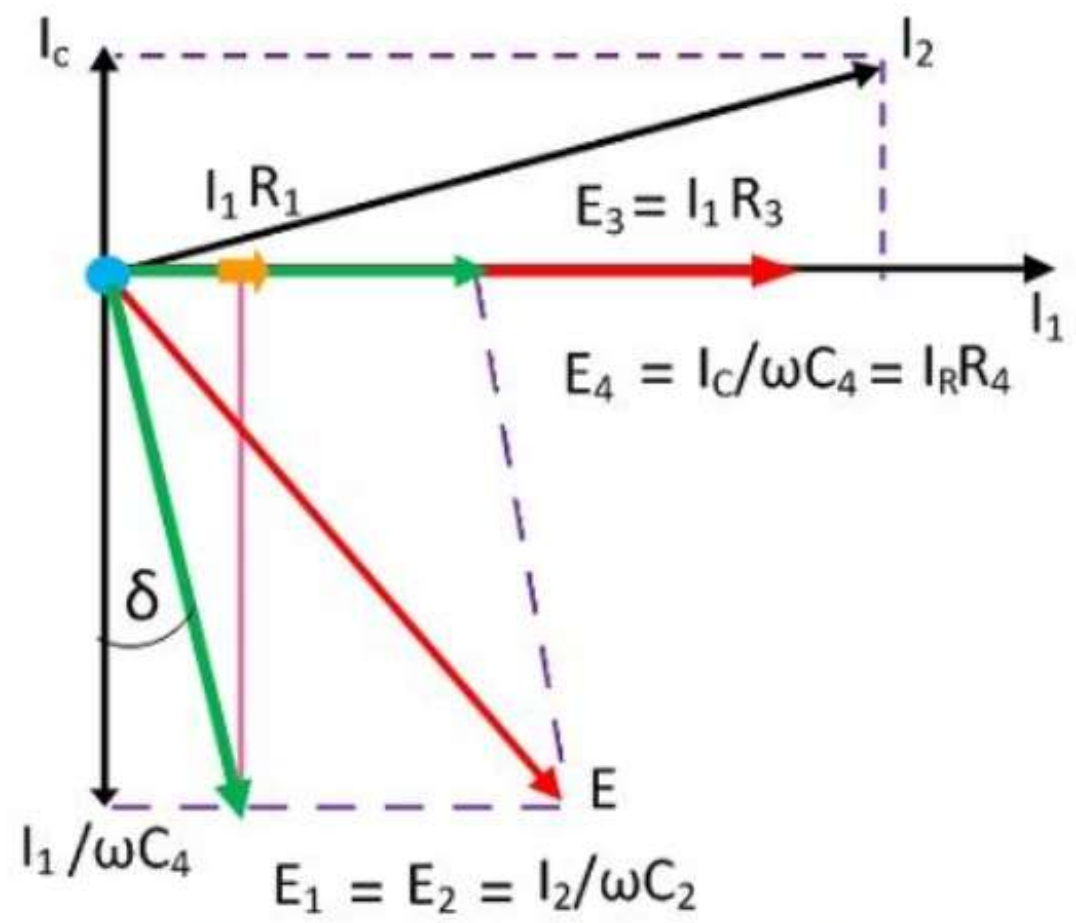

At balance condition, $\dot{Z}_1 \dot{Z}_4 = \dot{Z}_2 \dot{Z}_3$

$$\frac{1 + j\omega C_1 r_1}{j\omega C_1} \times \frac{R_4}{1 + j\omega C_4 R_4} = \frac{R_3}{j\omega C_2}$$

$$(1 + j\omega C_1 r_1) R_4 C_2 = R_3 C_1 (1 + j\omega C_4 R_4)$$

$$R_2 C_2 + j\omega C_1 r_1 R_4 C_2 = R_3 C_1 + j\omega C_4 R_4 R_3 C_1$$

Comparing the real part,

$$\therefore C_1 = \frac{R_4 C_2}{R_3}$$

Comparing the imaginary part,

$$\omega C_1 r_1 R_4 C_2 = \omega C_4 R_3 R_4 C_1$$

$$r_1 = \frac{C_4 R_3}{C_2}$$

Dissipation factor of capacitor,

$$D = \omega C_1 r_1 = \omega \times \frac{R_4 C_2}{R_3} \times \frac{C_4 R_3}{C_2}$$

$$\therefore D = \omega C_4 R_4$$

Wein's bridge

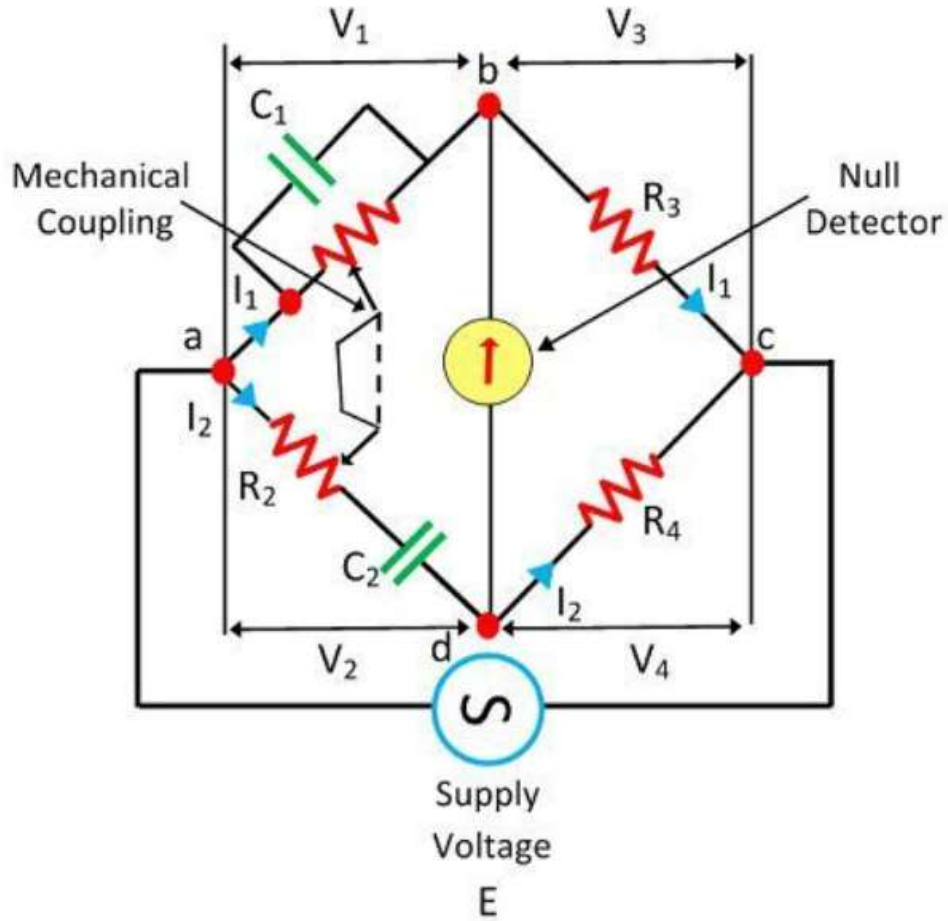

$$Z_1 = r_1 + \frac{1}{j\omega C_1} = \frac{j\omega C_1 r_1 + 1}{j\omega C_1}$$

$$Z_2 = \frac{R_2}{1 + j\omega C_2 R_2}$$

At balance condition, $\dot{Z}_1 \dot{Z}_4 = \dot{Z}_2 \dot{Z}_3$

$$\frac{j\omega C_1 r_1 + 1}{j\omega C_1} \times R_4 = \frac{R_2}{1 + j\omega C_2 R_2} \times R_3$$

$$(1 + j\omega C_1 r_1)(1 + j\omega C_2 R_2) R_4 = R_2 R_3 \times j\omega C_1$$

$$\left[1 + j\omega C_2 R_2 + j\omega C_1 r_1 - \omega^2 C_1 C_2 r_1 R_2 \right] = j\omega C_1 \frac{R_2 R_3}{R_4}$$

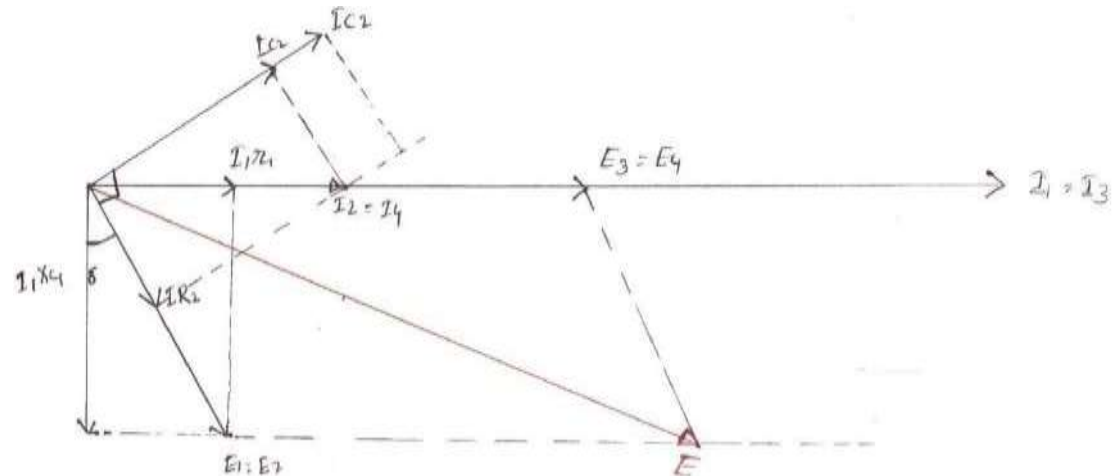

Comparing real

term,

$$1 - w^2 C_1 C_2 r_1 R_2$$

$$= 0$$

$$w^2 C_1 C_2 r_1 R_2 = 1$$

$$w^2 = \frac{1}{C_1 C_2 r_1 R_2}$$

$$w = \frac{1}{\sqrt{C_1 C_2 r_1 R_2}} \quad f = \frac{1}{2\pi \sqrt{C_1 C_2 r_1 R_2}}$$

UNIT- V
TRANSDUCERS

Introduction

- Basically transducer is defined as a device, which converts energy or information from one form to another. These are widely used in measurement work.
- A better measurement of a quantity can usually be made if it may be converted to another form, which is more conveniently or accurately displayed.

BLOCK DIAGRAM OF TRANSDUCERS

- Transducer contains two parts that are closely related to each other i.e. the sensing element and transduction element.
- The sensing element is called as the sensor. It is device producing measurable response to change in physical conditions.
- The transduction element convert the sensor output to suitable electrical form.

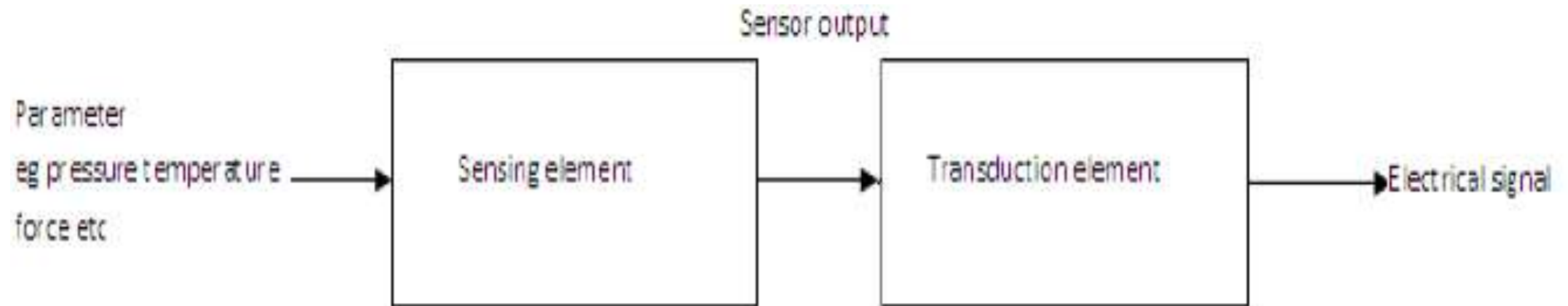

- A Transducer is a device which converts one form of energy into another form.
- Alternatively, a Transducer is defined as a device which provides usable output response to a specific input measured which may be a physical quantity.
- A Transducer can also be defined as a device when actuated by energy in one system supplies energy in the same form or in another form to a second system.

In general the **electrical transducers** are classified according to their structures, application areas, method of energy conversion, output signal nature.

The transducers can be classified as:

I.Active and passive transducers.

II.Analog and digital transducers.

III.On the basis of transduction principle used.

IV.Primary and secondary transducer

V.Transducers and inverse transducers.

Active and Passive Transducers

- **Active transducers :**
 - These transducers do not need any external source of power for their operation. Therefore they are also called as self generating type transducers.
- I. The active transducer are self generating devices which operate under the energy conversion principle.
 - II. As the output of active transducers we get an equivalent electrical output signal e.g. temperature or strain to electric potential, without any external source of energy being used

Active Transducers

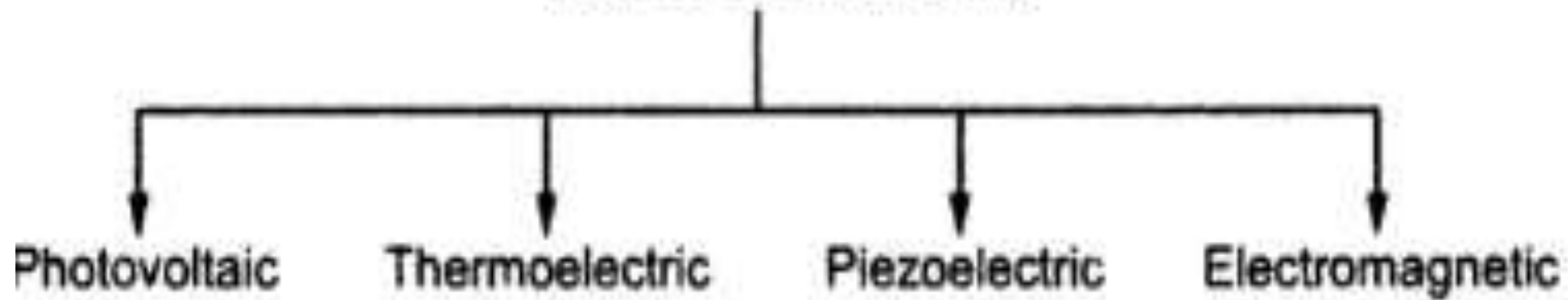

Example of active transducers

- **Piezoelectric Transducer-** When an external force is applied on to a quartz crystal, there will be a change in the voltage generated across the surface. This change is measured by its corresponding value of sound or vibration.

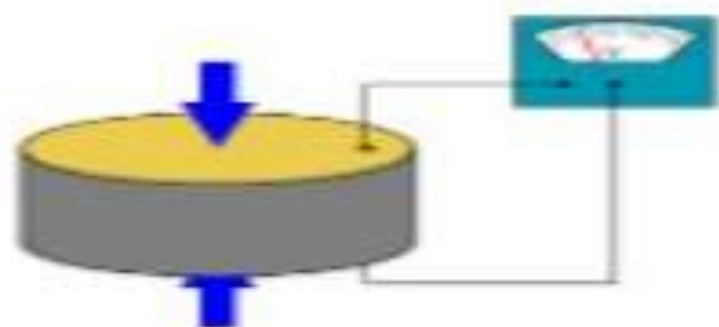

Passive Transducers

- These transducers need external source of power for their operation. So they are not self generating type transducers.
- A DC power supply or an audio frequency generator is used as an external power source.
- These transducers produce the output signal in the form of variation in electrical parameter like resistance, capacitance or inductance.
- Examples – Thermistor, Potentiometer type transducer

Passive Transducers

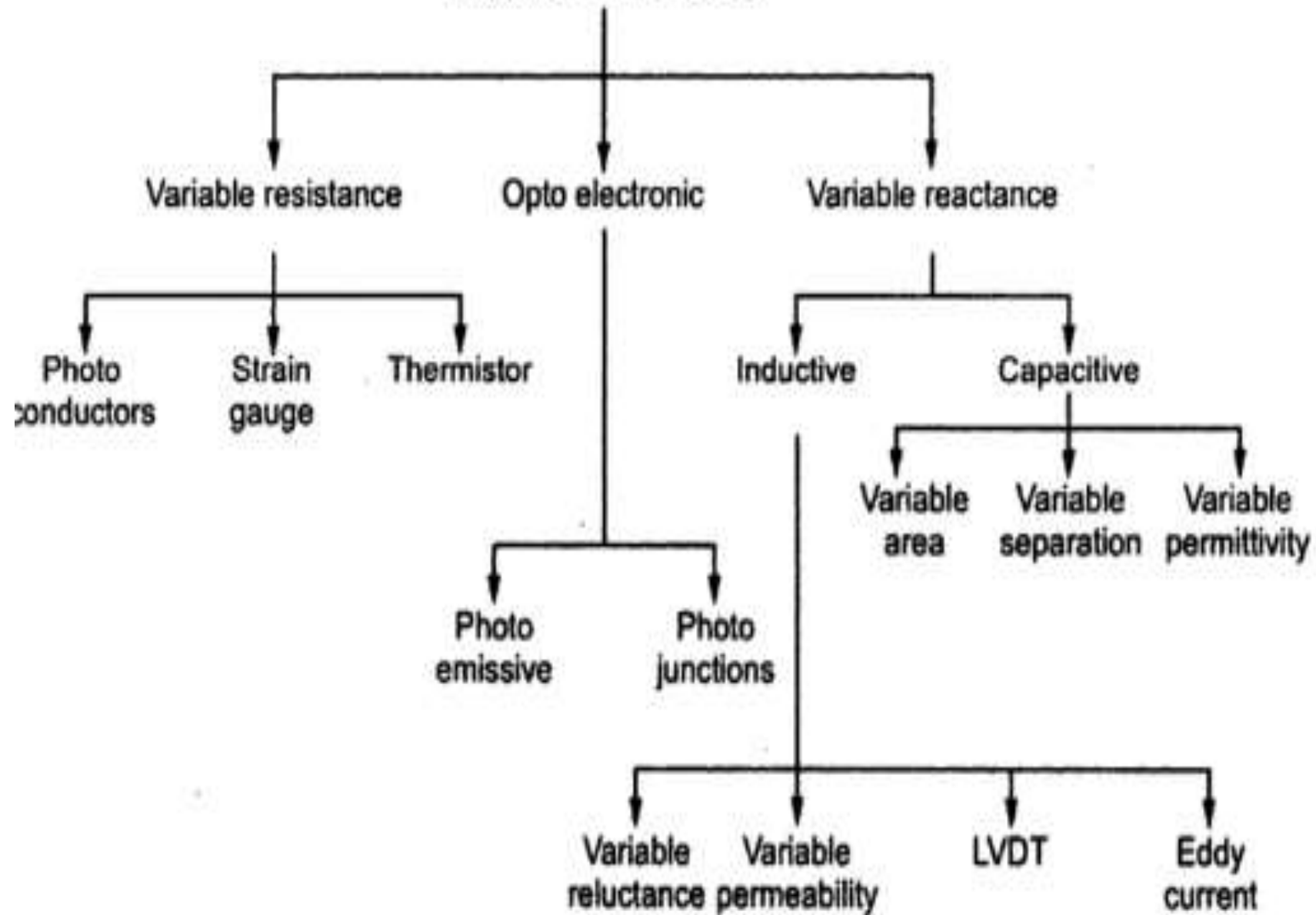

According to Transduction principle used

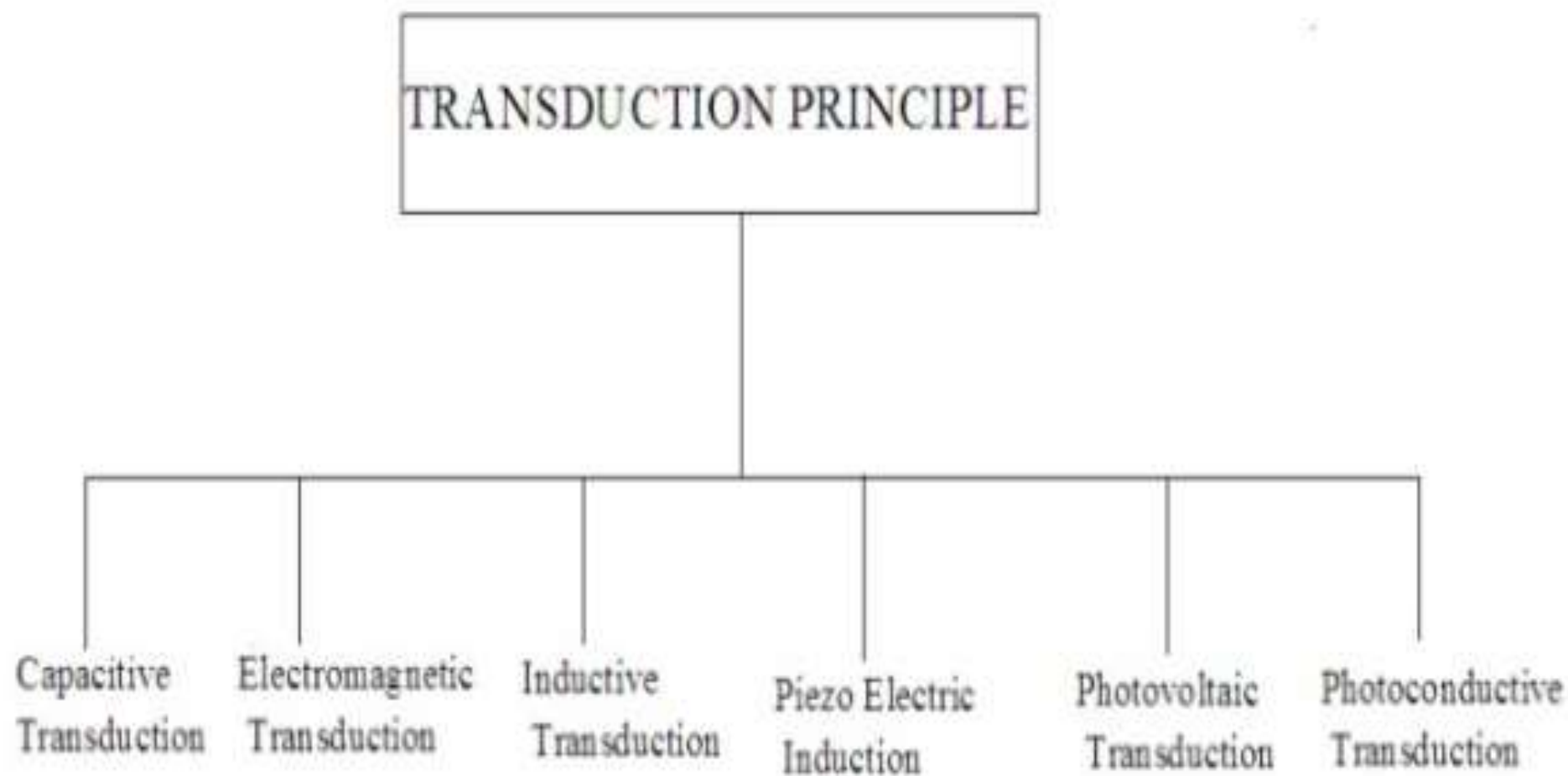

Capacitive Transduction:

- Here, the measurand is converted into a change in capacitance.
- A change in capacitance occurs either by changing the distance between the two plates or by changing the dielectric.

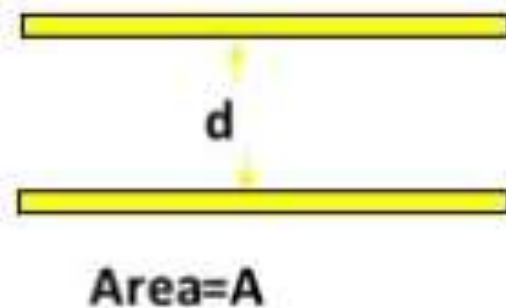

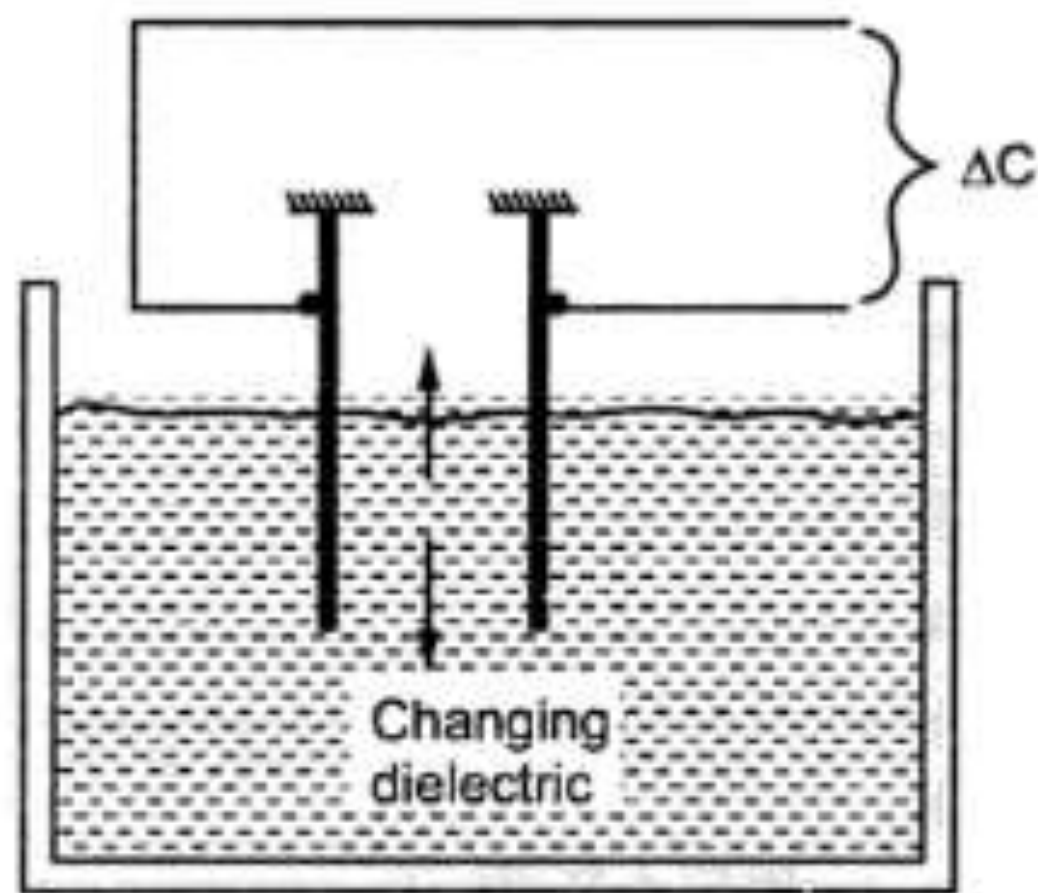
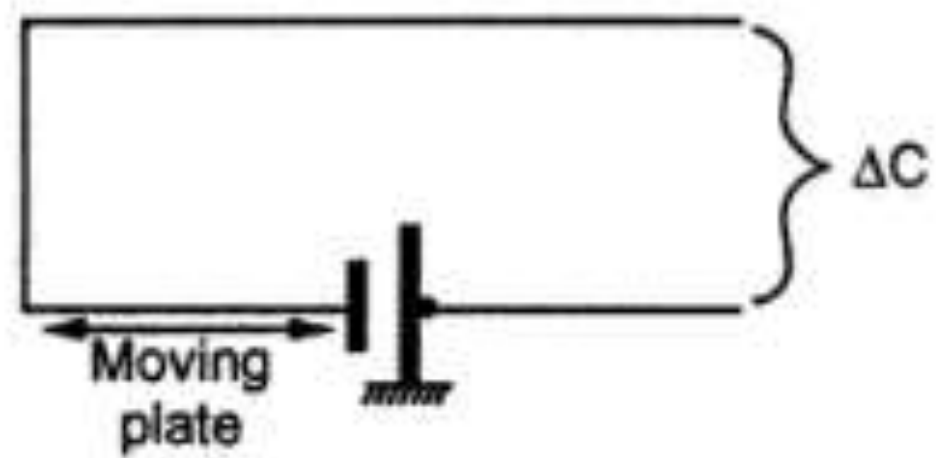

(a)

Fig. 9.5 Capacitive transduction

(b)

Electromagnetic transduction:

- In electromagnetic transduction, the measurand is converted to voltage induced in conductor by change in the magnetic flux, in absence of excitation.
- The electromagnetic transducer are self generating active transducers
- The motion between a piece of magnet and an electromagnet is responsible for the change in flux

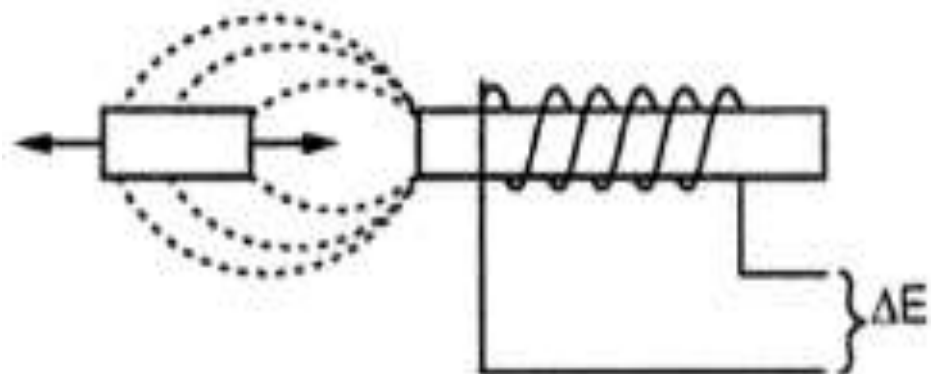
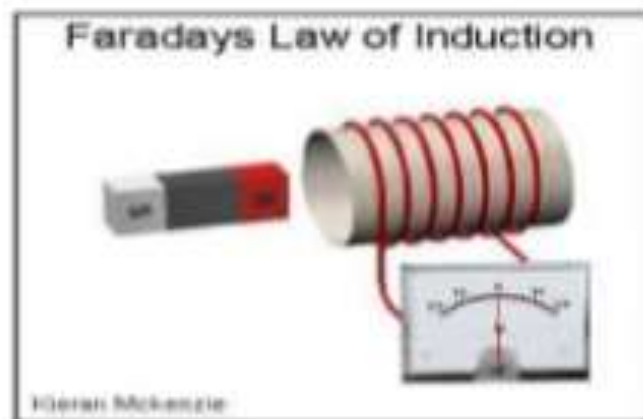

Inductance Transduction:

- In inductive transduction, the measurand is converted into a change in the self inductance of a single coil. It is achieved by displacing the core of the coil that is attached to a mechanical sensing element

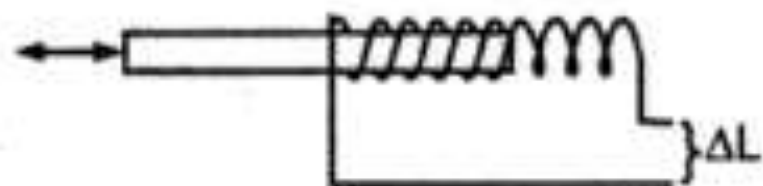

Inductive transduction

Piezoelectric Transduction:

- In piezoelectric induction the measurand is converted into a change in electrostatic charge q or voltage V generated by crystals when it is mechanically stressed.

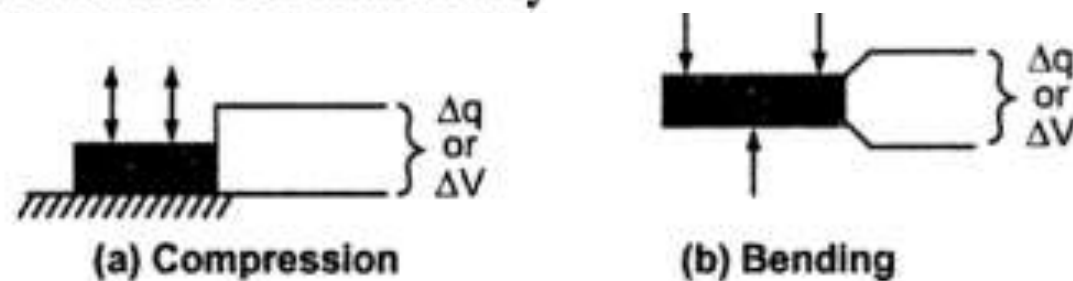

Fig. 9.8 Piezoelectric transduction

Photovoltaic Transduction:

- In photovoltaic transduction the measurand is converted to voltage generated when the junction between dissimilar material is illuminated.

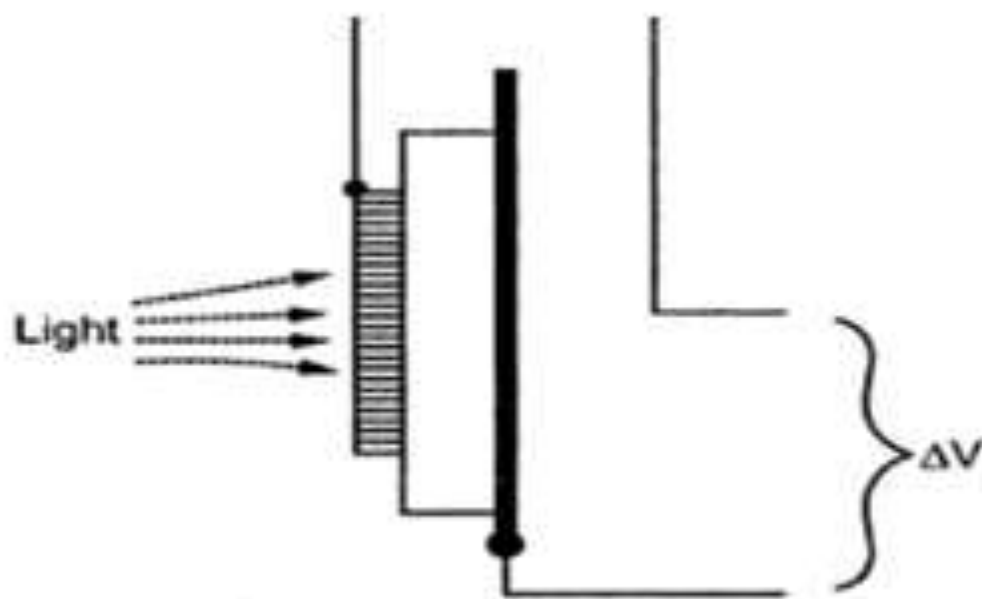

Fig. 9.9 Photovoltaic transduction

Photoconductive Transduction:

- In photoconductive transduction the measurand is converted to change in resistance of semiconductor material by the change in light incident on the material.

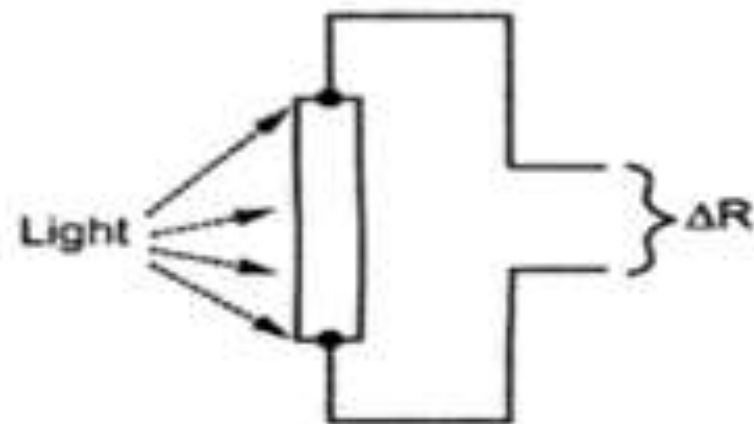

Fig. 9.10 Photoconductive transduction

Analog and Digital Transducers

Analog transducers:

- These transducers convert the input quantity into an analog output which is a continuous function of time.
- Thus a **strain gauge**, an **L.V.D.T.**, a **thermocouple** or a **thermistor** may be called as Analog Transducers as they give an output which is a continuous function of time.

Digital Transducers:

- These transducers convert the input quantity into an electrical output which is in the form of pulses and its output is represented by 0 and 1.

Primary and Secondary Transducers

- Some transducers contain the mechanical as well as electrical device. The mechanical device converts the physical quantity to be measured into a mechanical signal. Such mechanical device are called as the primary transducers, because they deal with the physical quantity to be measured.
- The electrical device then convert this mechanical signal into a corresponding electrical signal. Such electrical device are known as secondary transducers.

Example of Primary and secondary transducer

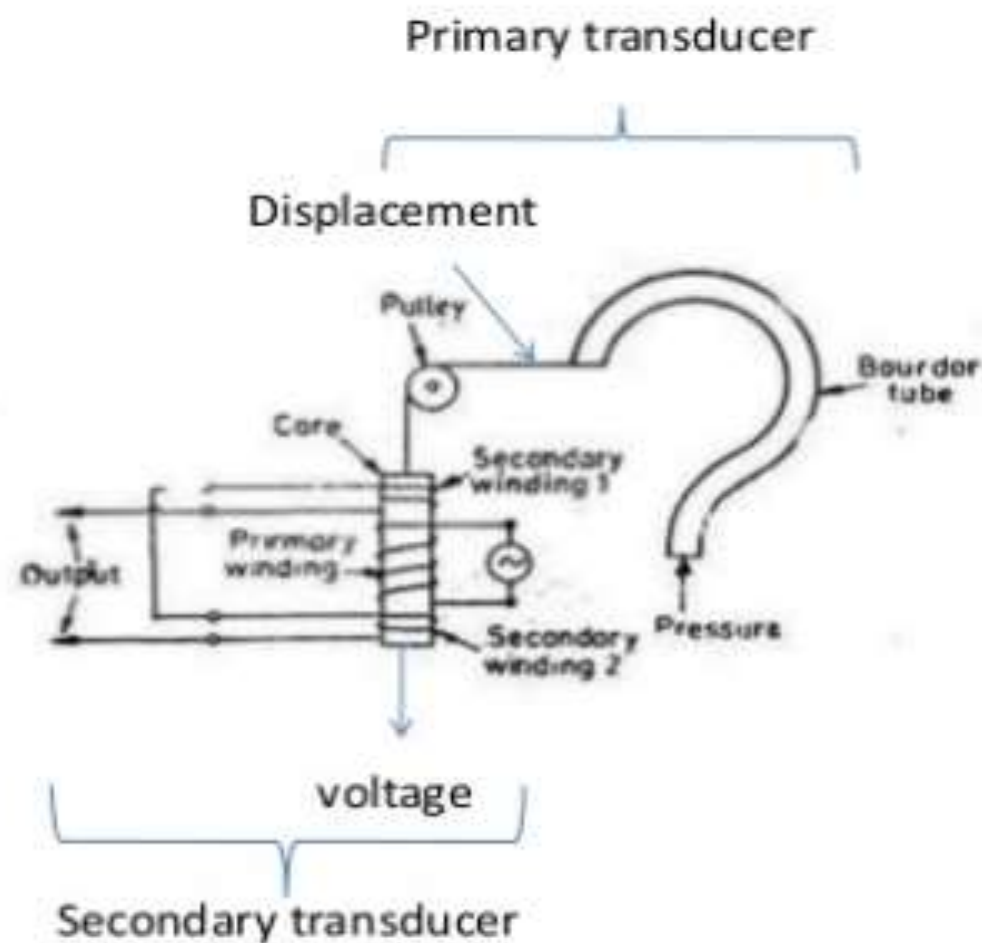

Transducer and Inverse Transducer

Transducer:

- Transducers convert non electrical quantity to electrical quantity.

Inverse Transducer:

- Inverse transducers convert electrical quantity to a non electrical quantity. A piezoelectric crystal acts as an inverse transducer because when a voltage is applied across its surfaces, it changes its dimensions causing a mechanical displacement.

Factors influencing the choice of transducers

- 1. Operating Principle:** The transducers are many times selected on the basis of operating principle used by them. The operating principle used may be resistive, inductive, capacitive, opto electronic, piezoelectric etc.
- 2. Sensitivity:** The transducer should give a sufficient output signal per unit of measured input in order to yield meaningful data. The transducer must be sensitive enough to produce detectable output.
- 3. Operating Range:** The transducer should maintain the range requirements and have a good resolution over its entire range. The rating of the transducer should be sufficient so that it does not breakdown while working in its specified operating range.

4. **Accuracy:** High degree of accuracy assured if the transducer does not require frequent calibration and has a small value for repeatability. It may be emphasized that in most industrial applications, repeatability is of considerably more importance than absolute accuracy.
5. **Cross sensitivity:** It should be considered when measuring mechanical quantities. There are situations where the actual quantity is being measured is in one plane and the transducer is subjected to variations in another plane.
6. **Errors:** The errors inherent in the operation of the transducer itself, or those errors caused by environmental conditions of the measurement, should be small enough or controllable enough that they allow meaningful data to be taken. Transducer should maintain the input-output relationship to avoid errors.

7. **Transient and Frequency Response:** The transducer should meet the desired time domain specifications like peak overshoot, rise time, settling time and small dynamic error. It should ideally have a flat frequency response. It should have high cut off frequency to have wide bandwidth.

8. **Loading effects:** The transducer should have high input impedance and low output impedance to avoid loading effects.

9. **Environmental Compatibility:** Transducer selected to work under specified environmental conditions should maintain its input-output relationship and does not breakdown. For eg. Transducer should remain operable under its temperature range, It should work in corrosive environments, should be able to withstand pressures, shocks and other interactions to which it is subjected to.

- 10. In-sensitivity to unwanted signals:** Transducer should be minimally sensitive to unwanted signals and highly sensitive to desired signal.
- 11. Usage and Ruggedness:** Ruggedness both mechanical and electrical intensities transducer versus its size and weight must be considered while selecting a suitable transducer.
- 12. Electrical aspects:** Length and type of cable required need to be considered while selecting a transducer. Attention must be paid to signal to noise ratio in case transducer is used in conjunction with amplifiers.
- 13. Stability and reliability:** It should have high degree of stability during its operation and storage life. Reliability should be assured in case of failure of transducer in order that the functioning of the instrumentation system continue uninterrupted.

14.Static Characteristics: Apart from low static error, the transducers should have a low non-linearity, low hysteresis, high resolution and a high degree of repeatability.

The transducer selected should be free from load alignment effects and temperature effects. It should not need frequent calibration should not have any component limitations and should be preferably small in size.

Resistive transducer

Resistive transducers are those transducers in which the resistance change due to the change in some physical phenomenon.

The resistance of a metal conductor(electrical conductor) is expressed by a simple equation.

$$R = \rho L/A$$

Where $R =$ resistance of conductor in Ω

$L =$ length of conductor in m

$A =$ cross sectional area of conductor in m^2

$\rho =$ resistivity of conductor material in $\Omega\text{-m}$.

The electrical resistance can be varied by varying,

(i) Length (ii) Cross-sectional area and (iii) Resistivity or combination of these.

Principle:-

- A change in resistance of a circuit due to the displacement of an object is the measure of displacement of that object.

Applications of Resistive Transducer

- **Potentiometer** – The translation and rotatory potentiometer are the examples of the resistive transducers. The resistance of their conductor varies with the variation in their **lengths** which is used for the measurement of displacement.
- **Strain gauges** –When a metal conductor is subjected to mechanical strain, change in **dimensions** of the conductor occurs, that changes the resistance of the conductor. This property of metals is used for the measurement of the pressure, force, displacement etc.

- **Resistance Thermometer** – When a metal conductor is subjected to a change in temperature and change in **resistivity** occurs which changes resistance of the conductor. This property of conductor is used for measuring the temperature
- **Thermistor** – It works on the principle that the temperature coefficient of the thermistor material varies with the temperature. The thermistor has the negative temperature coefficient. The Negative temperature coefficient means the temperature is inversely proportional to resistance.

There are a number of ways because of which the resistance of the metal changes with the changed in the physical phenomenon. And this property of conductors is used for measuring the physical quantities of material.

Potentiometric resistance transducers

- It is used to measure linear and angular displacement. It consists of a resistive element and a sliding contact called wiper.
- The contact motion may be linear or rotational or combination of the two. The combinational potentiometer have their resistive element in helix form and are called helipots.

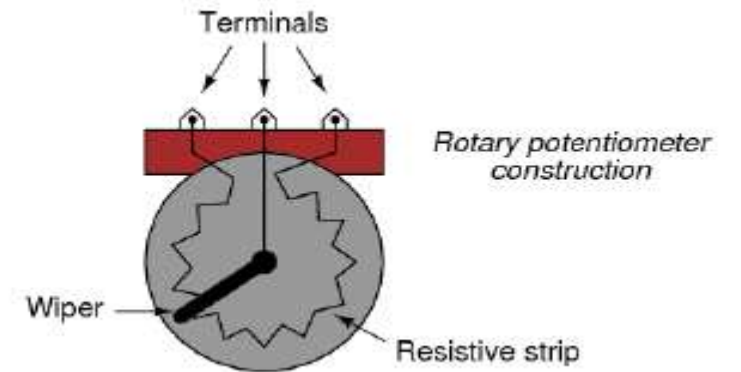
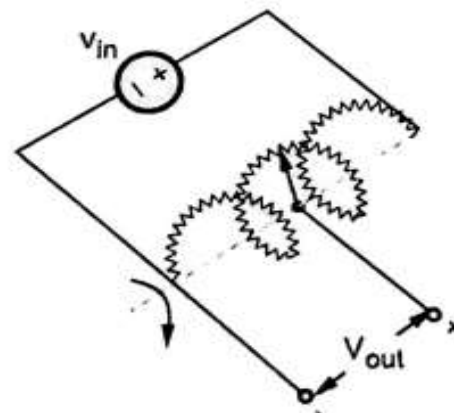
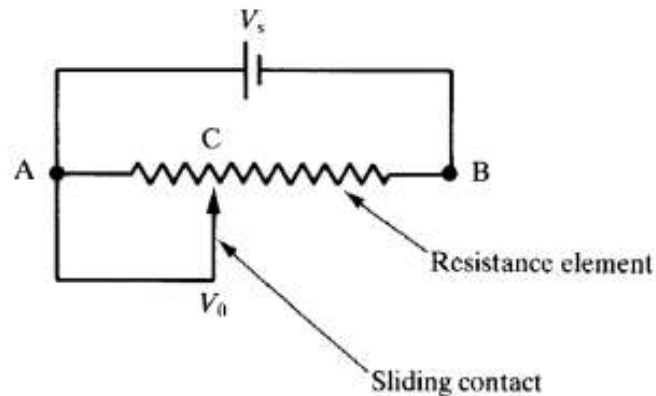

(c) Helipot

- Using resistance potentiometer, mechanical displacement is converted into an electrical output.
- Linear or angular displacement is applied to the sliding contact and then the corresponding change in resistance is converted into voltage or current.
- The resistance potentiometer may be excited by either AC voltage or DC voltage.

Advantages:

- Simple in construction and operation.
- Inexpensive
- Useful for displacement measurements of large amplitudes

Disadvantages:

- In linear POT, large force is required to move the wiper.
- Suffer from mechanical wear and misalignment of wiper. High electronic noise in output.

Strain gauge

- The strain gauge is a passive, resistive transducer which converts the mechanical elongation and compression into a resistance change.
- This change in resistance takes place due to variation in length and cross sectional area of the gauge wire, when an external force acts on it.
- Strain gauges are displacement-type transducers that measure changes in the length of an object as a result of an applied force. These transducers produce a resistance change that is proportional to the fractional change in the length of the object, also called strain, S , which is defined as

$$S = \Delta l / l$$

where

Δl is the fractional change in length

l is the initial length of the object.

Contd....

- Any basic strain gauge consists of an insulating flexible backing that supports a metallic foil pattern. The gauge is attached to the object under stress using an adhesive. The deformation in the object causes the foil to get distorted which ultimately changes the electrical resistivity of the foil. This change in resistivity is measured by a Wheatstone bridge which is related to strain by a quantity called, Gauge Factor.

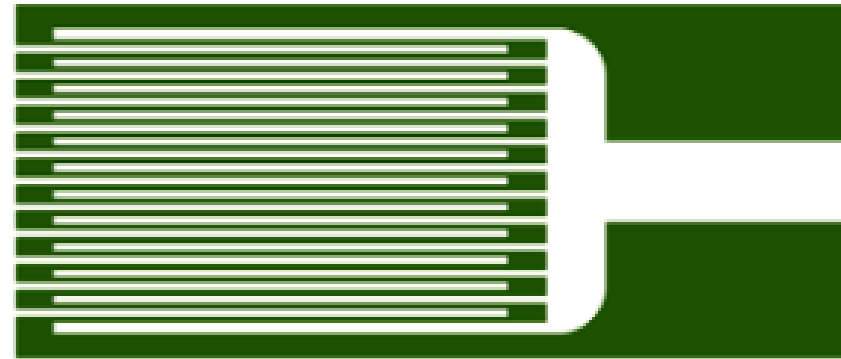
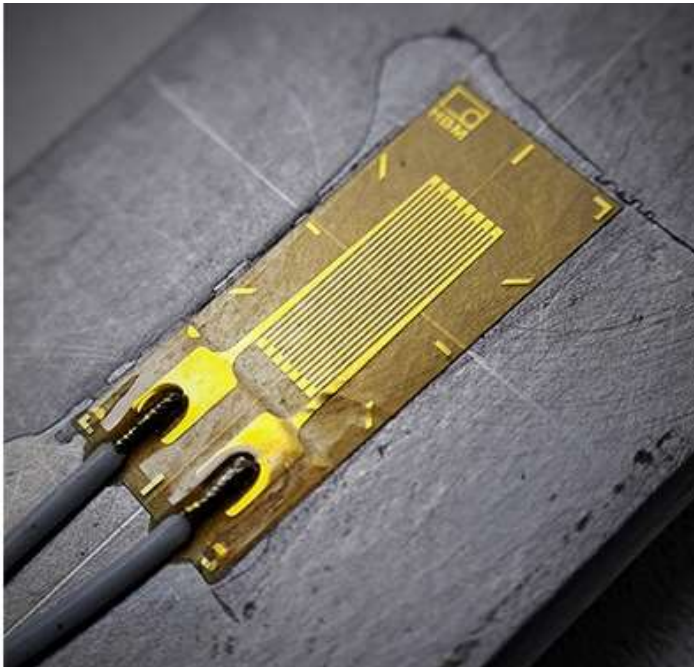

Contd....

- In this circuit, R_1 and R_3 are the ratio arms equal to each other, and R_2 is the rheostat arm has a value equal to the strain gage resistance. When the gauge is unstrained, the bridge is balanced, and voltmeter shows zero value. As there is a change in resistance of strain gauge, the bridge gets unbalanced and producing an indication at the voltmeter. The output voltage from the bridge can be amplified further by a differential amplifier.

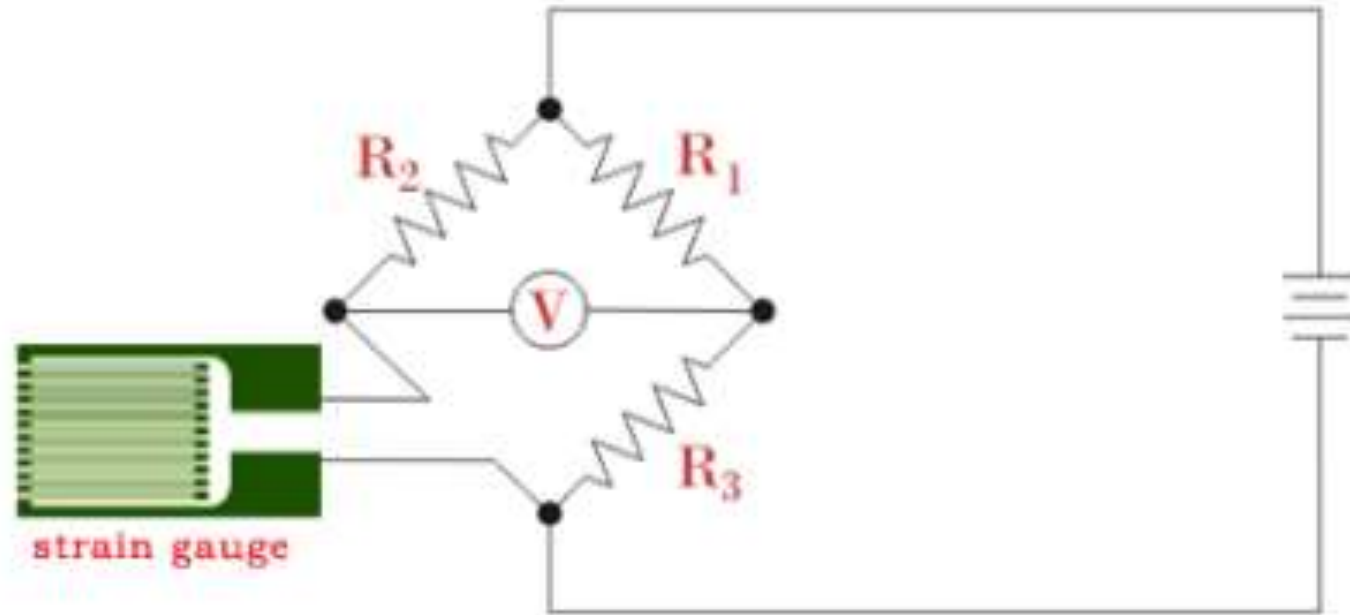

Types of Strain Gauge

The type of strain gauge are as

- 1. Wire gauge
 - a) Unbonded
 - b) Bonded
 - c) Foil type
- 2. Semiconductor gauge

1. Wire strain gauge:-

In this type of strain gauge the strain is sensed with the help of wire.

Derivation of Gauge Factor (G_f) | Strain Gauge Factor

Derivation

- Consider a strain gauge made of circular wire having length 'L', area 'A', and diameter 'D' before being strained. The material of the wire has a resistivity ρ .

$$\therefore \text{Resistance of unstrained gauge (R)} = \frac{\rho L}{A} \dots \text{Eq.(1)}$$

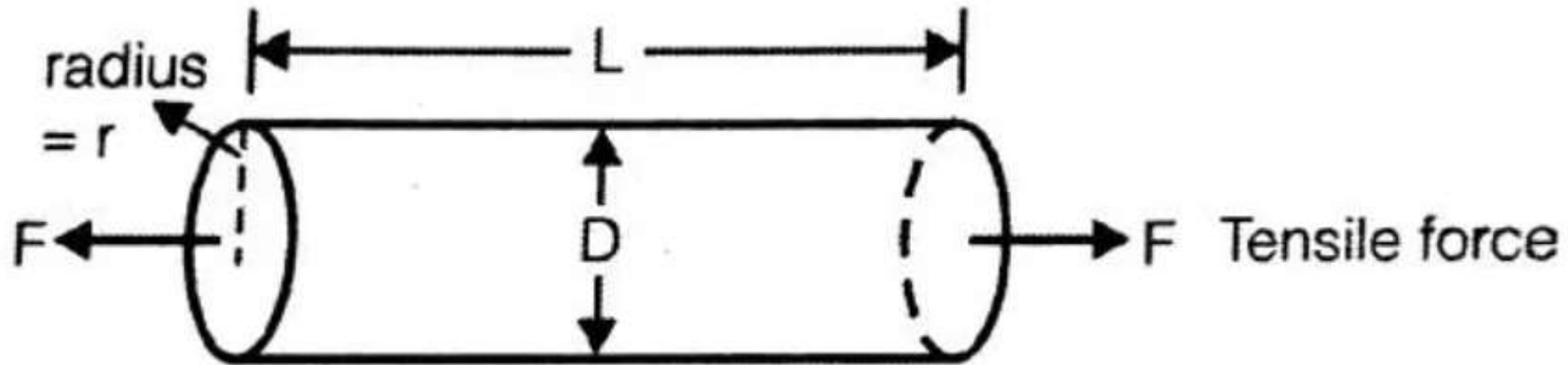

When a tensile force 'F' is applied the circular wire changes its dimensions as in the figure below.

Let a tensile stress s be applied to the wire. This produces a positive strain causing the length to increase and area to decrease as shown in Fig. 25.55. Thus when the wire is strained there are changes in its dimensions. Let $\Delta L =$ change in length, $\Delta A =$ change in area, $\Delta D =$ change in diameter and $\Delta R =$ change in resistance.

In order to find how ΔR depends upon the material physical quantities, the expression for R is differentiated with respect to stress s .

Thus we get :

$$\frac{dR}{ds} = \frac{\rho}{A} \frac{\partial L}{\partial s} - \frac{\rho L}{A^2} \frac{\partial A}{\partial s} + \frac{L}{A} \frac{\partial \rho}{\partial s} \quad \dots(25.59)$$

Dividing Eqn. 25.59 throughout by resistance $R = \rho L / A$, we have

$$\frac{1}{R} \frac{dR}{ds} = \frac{1}{L} \frac{\partial L}{\partial s} - \frac{1}{A} \frac{\partial A}{\partial s} + \frac{1}{\rho} \frac{\partial \rho}{\partial s} \quad \dots(25.60)$$

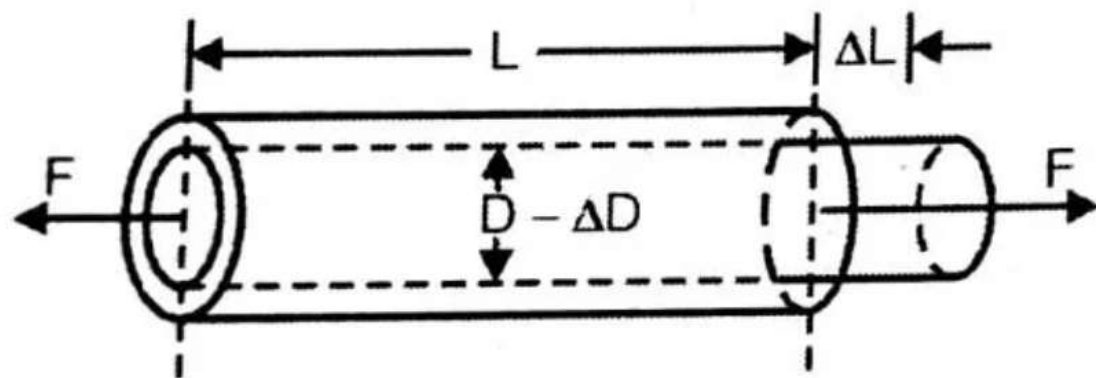

It is evident from Eqn. 25.60, that the per unit change in resistance is due to :

- (i) per unit change in length = $\Delta L / L$,
- (ii) per unit change in area = $\Delta A / A$, and
- (iii) per unit change in resistivity = $\Delta \rho / \rho$

$$\text{Area } A = \frac{\pi}{4} D^2 \quad \therefore \frac{\partial A}{\partial s} = 2 \cdot \frac{\pi}{4} D \cdot \frac{\partial D}{\partial s} \quad \dots(25.61)$$

$$\text{or } \frac{1}{A} \frac{dA}{ds} = \frac{(2\pi/4)D}{(\pi/4)D^2} \frac{\partial D}{\partial s} = \frac{2}{D} \frac{\partial D}{\partial s} \quad \dots(25.62)$$

\therefore Equation 25.60 can be written as :

$$\frac{1}{R} \frac{dR}{ds} = \frac{1}{L} \frac{\partial L}{\partial s} - \frac{2}{D} \frac{\partial D}{\partial s} + \frac{1}{\rho} \frac{\partial \rho}{\partial s} \quad \dots(25.63)$$

Now, Poisson's ratio

$$\nu = \frac{\text{lateral strain}}{\text{longitudinal strain}} = -\frac{\partial D / D}{\partial L / L} \quad \dots(25.64)$$

Now, Poisson's ratio

$$\nu = \frac{\text{lateral strain}}{\text{longitudinal strain}} = -\frac{\partial D / D}{\partial L / L} \quad \dots(25.64)$$

or $\partial D / D = -\nu \times \partial L / L$

$$\therefore \frac{1}{R} \frac{dR}{ds} = \frac{1}{L} \frac{\partial L}{\partial s} + \nu \frac{2}{L} \frac{\partial L}{\partial s} + \frac{1}{\rho} \frac{\partial \rho}{\partial s} \quad \dots(25.65)$$

For small variations, the above relationship can be written as :

$$\frac{\Delta R}{R} = \frac{\Delta L}{L} + 2\nu \frac{\Delta L}{L} + \frac{\Delta \rho}{\rho} \quad \dots(25.66)$$

The gauge factor is defined as the ratio of per unit change in resistance to per unit change in length.

$$\text{Gauge factor } G_f = \frac{\Delta R / R}{\Delta L / L} \quad \dots(25.67)$$

or

$$\frac{\Delta R}{R} = G_f \frac{\Delta L}{L} = G_f \times \epsilon \quad \dots(25.68)$$

where $\epsilon = \text{strain} = \frac{\Delta L}{L}$

The gauge factor can be written as :

$$= 1 + 2\nu + \frac{\Delta\rho / \rho}{\epsilon} \quad \dots(25.69)$$

$$= 1 + 2\nu + \frac{\Delta\rho / \rho}{\epsilon}$$

Resistance
change due to
change of length

Resistance
change due to
change in area

Resistance
change due to
piezoresistive effect

$$G_f = \frac{\Delta R / R}{\Delta L / L} = 1 + 2\nu + \frac{\Delta\rho / \rho}{\Delta L / L}$$

$$G_f = \frac{\Delta R / R}{\Delta L / L} = 1 + 2\nu + \frac{\Delta \rho / \rho}{\Delta L / L}$$

The strain is usually expressed in terms of microstrain. 1 microstrain = 1 $\mu\text{m} / \text{m}$.

If the change in the value of resistivity of a material when strained is neglected, the gauge factor is :

$$G_f = 1 + 2\nu \quad \dots(25.70)$$

Equation 25.70 is valid only when **Piezoresistive Effect** *i.e.*, change in resistivity due to strain is almost negligible.

The Poisson's ratio for all metals is between 0 and 0.5. This gives a gauge factor of approximately, 2. The common value for Poisson's ratio for wires is 0.3. This gives a value of 1.6 for wire wound strain gauges.

**Inductive transducer ,
Capacitive transducer**

Inductive transducer

- An inductive electromechanical transducer is a transducer which converts the physical motion into the change in inductance.
- Inductive transducers are mainly used for displacement measurement.
- The inductive transducers are of the self generating or the passive type. The self generating inductive transducers use the basic generator principle i.e. the motion between a conductor and magnetic field induces a voltage in the conductor.

Inductive transducer

- The variable inductance transducers work on the following principles.
 - Variation in self inductance
 - Variation in mutual inductance

PRINCIPLE OF VARIATION OF SELF INDUCTANCE

- Let us consider an inductive transducer having N turns and reluctance R . when current I is passed through the transducer, the flux produced is

$$\Phi = Ni / R$$

Differentiating w.r.t. to t ,

$$d\Phi/dt = N/R * di/dt$$

The e.m.f. induced in a coil is given by

$$e = N * d\Phi/dt$$

$$e = N * N/R * di/dt$$

$$e = N^2 / R * di/dt$$

Self inductance of an inductor is given by

$$L = e/di/dt = N^2 / R$$

Contd....

The reluctance of the magnetic circuit is $R = l/\mu A$

$$\text{Therefore } L = N^2 / l/\mu A = N^2 \mu A / l$$

$N \rightarrow$ number of turns of coil

$\mu \rightarrow$ Permeability of core

$A \rightarrow$ Area of magnetic circuit through which flux is passing

$l \rightarrow$ Length of the magnetic circuit

➤ Variation of self inductance may be due to

(i) change in number of turns

(ii) change in reluctance

(iii) Change in permeability

CHANGE IN SELF INDUCTANCE WITH CHANGE IN NUMBER OF TURNS N

- From equation $L = N^2 \mu A / l$, L vary with the variation in the number of turns.
- As inductive transducers are mainly used for displacement measurement, with change in number of turns the self inductance of the coil changes in-turn changing the displacement
- Fig shows transducers used for linear and angular displacement

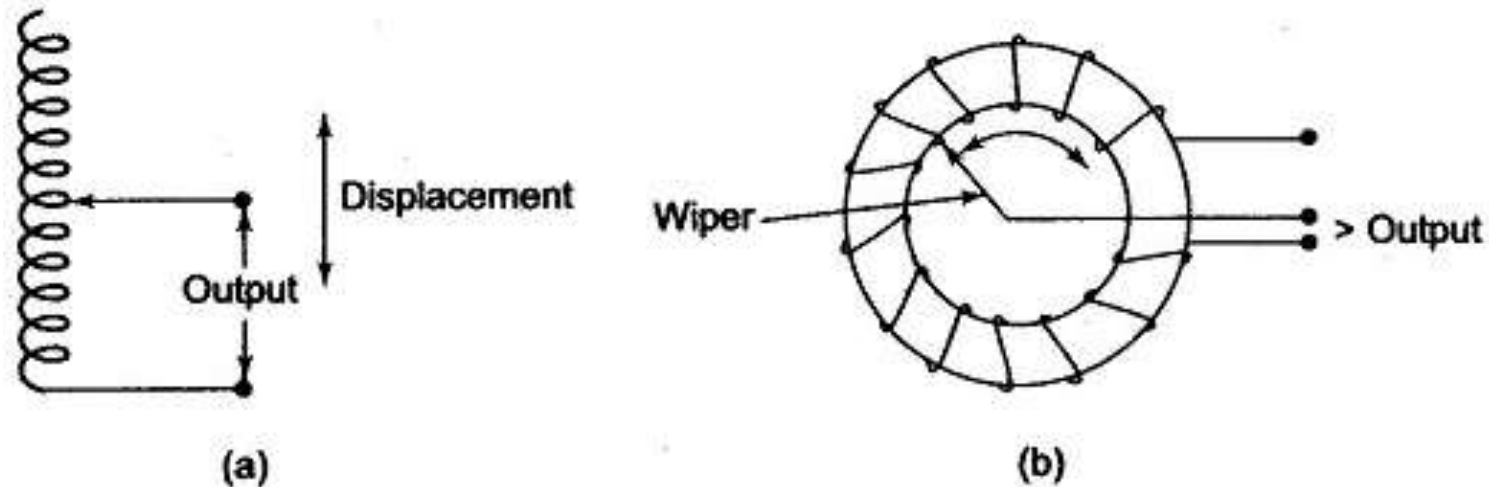

(a) Linear Inductive Transducer (Using Air Core) (b) Angular Inductive Transducer (Using Ferrite Core)

CHANGE IN SELF INDUCTANCE WITH CHANGE IN PERMEABILITY

- The value of self inductance of a coil also depends on the permeability.
- The iron core is surrounded by a winding. The displacement to be measured is applied to the rod which moves in and out of the ferrite core according to the direction of the displacement.
- When iron core moves in, permeability increases when iron core moves out permeability decreases. This cause the self inductance of the coil to increase or decrease depending on the permeability and accordingly the output voltage changes.

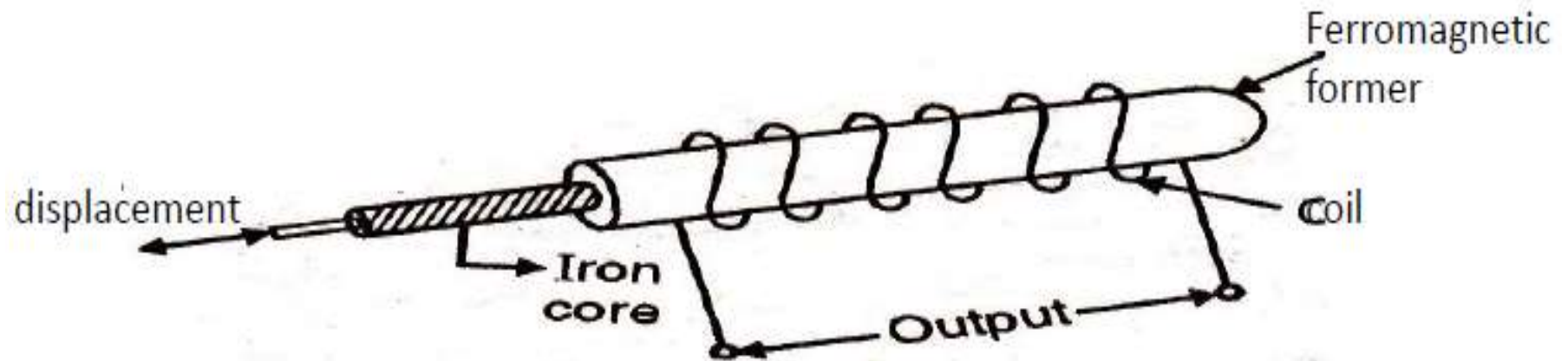

VARIABLE RELUCTANCE INDUCTIVE TRANSDUCER

- From equation $L = N^2 / R$, L is inversely proportional to reluctance.
- The coil is wound on the ferromagnetic iron core. The target and core are not in direct contact with each other. They are separated by an air gap. The size of the air gap determines the reluctance of the magnetic circuit, which in turns decides the self inductance.
- The displacement is applied to the target plate. According to the displacement the target plate moves which changes the air gap and hence the self inductance.

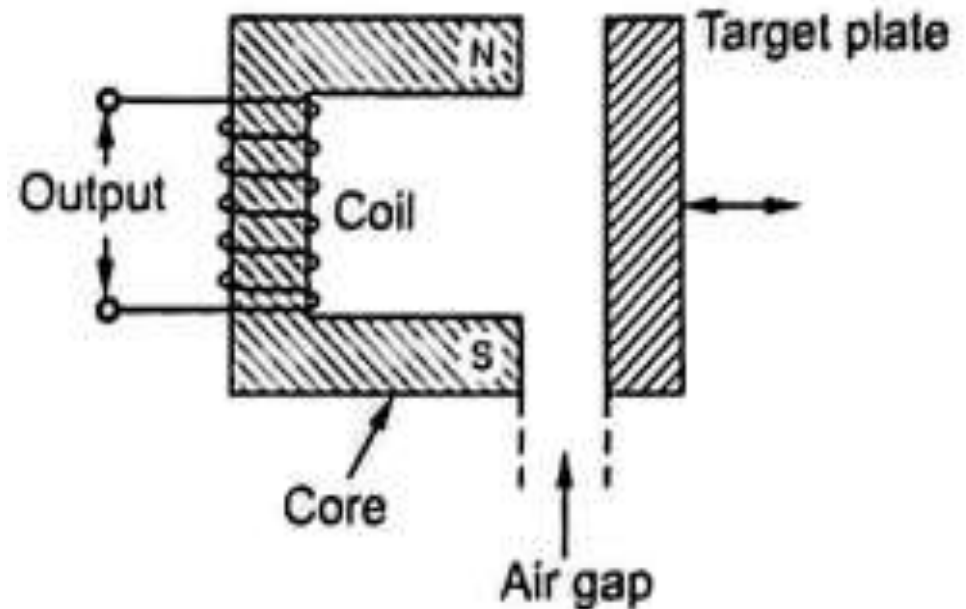

PRINCIPLE OF CHANGE IN MUTUAL INDUCTANCE

- The mutual inductance between two coils is given by

$$M = K\sqrt{L_1L_2}$$

Where

M : mutual inductance

K : coefficient of coupling

L1: self inductance of coil 1

L2 : self inductance of coil 2

- By varying the self inductance or the coefficient of coupling the mutual inductance can be varied

Linear Variable Differential Transducer (LVDT)

- Displacement is a vector quantity representing a change in position of a body or a point with respect to a reference. It can be linear or angular motion.
- By using displacement transducer many other quantities such as force, stress, pressure, velocity and acceleration also can be found.
- A simple and most popular type of displacement transducer is **variable inductance type transducer** wherein the inductance is varied according to displacement.
- It is achieved by varying the mutual inductance between the coil or by varying the self inductance.

Construction of LVDT

- The most widely used inductive transducer to translate the linear motion into electrical signal is the **Linear Variable Differential Transformer (LVDT)**
- The transformer consists of a single primary winding P and two secondary windings S1,S2 wound on a cylindrical former.
- The secondary windings have equal number of turns and are identically placed on either side of the primary winding.
- The primary winding is connected to the alternating current source. A movable soft iron core is placed inside the former.
- The displacement to be measured is applied to the arm attached to the soft iron core.

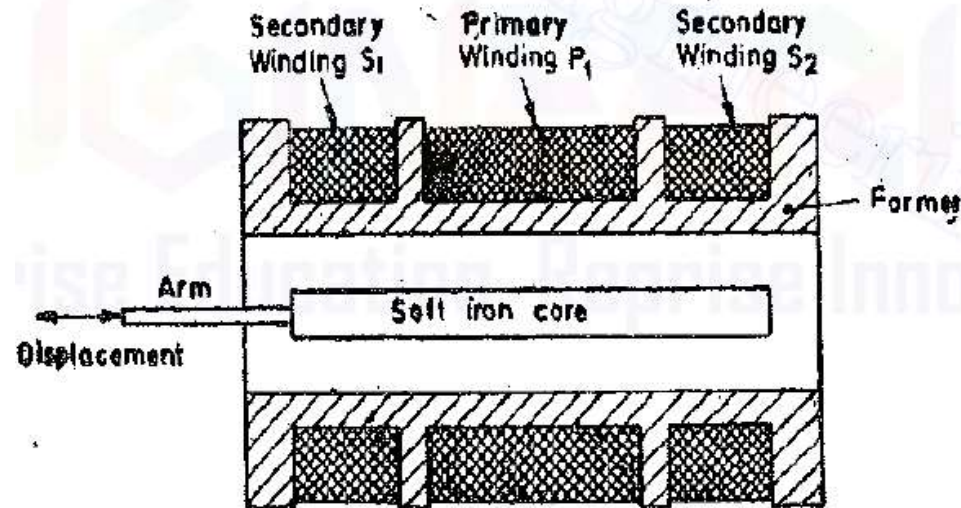

- The iron core is generally of high permeability which helps in reducing harmonics and high sensitivity of LVDT.
- The LVDT is placed inside a stainless steel housing because it will provide electrostatic and electromagnetic shielding.

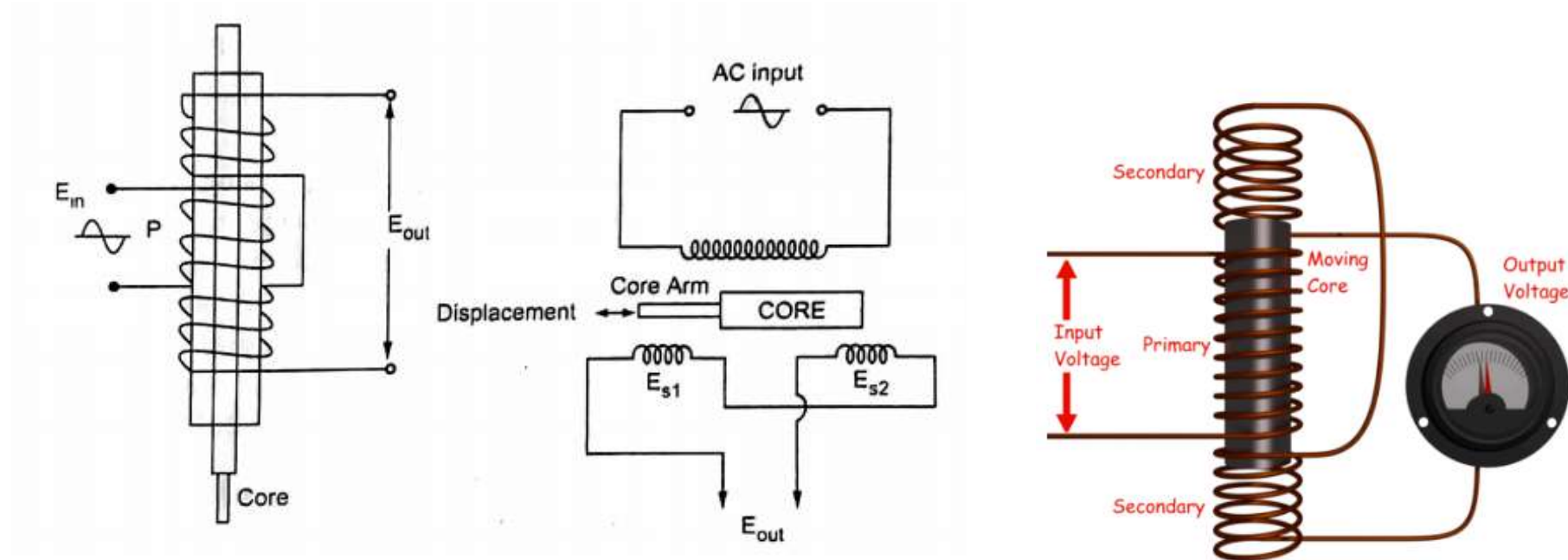

working of LVDT

- As the primary is connected to an AC source so alternating current and voltages are produced in the two secondary windings of the LVDT.
- The output in secondary S_1 is E_{s1} and in the secondary S_2 is E_{s2} .
- In order to convert the output from s_1 and s_2 into a single voltage signal, the two secondaries are connected in series opposition.
- Thus the output voltage of the transducer is the difference of the two voltages . So the differential output voltage is ,

$$E_o = E_{s1} - E_{s2}$$

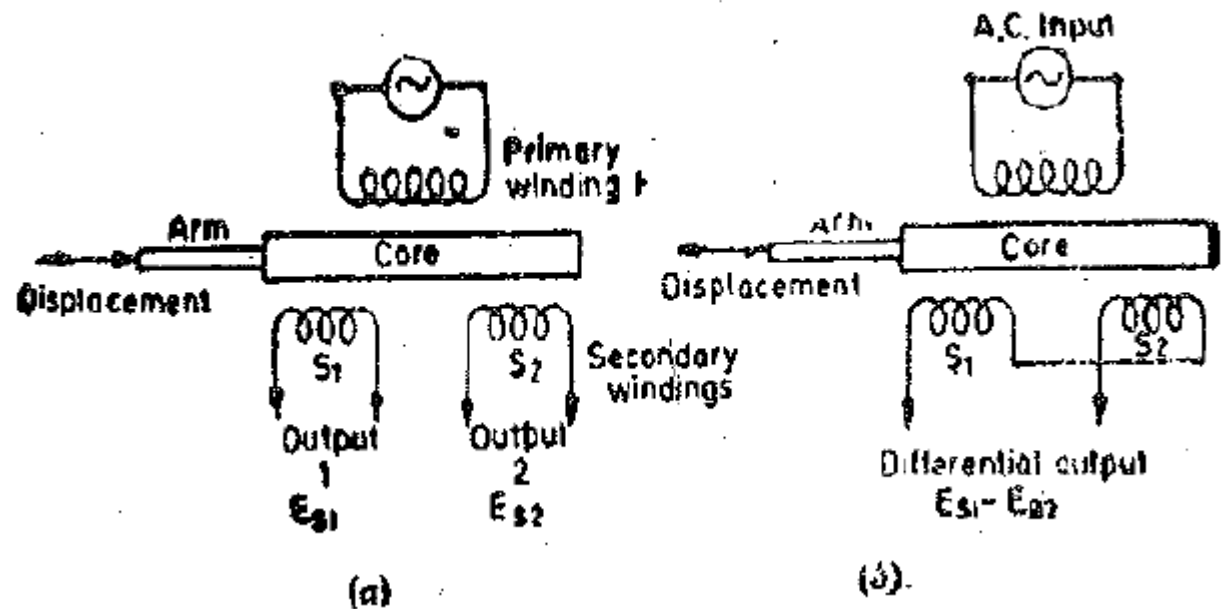

Now three cases arise according to the locations of core which explains the working of LVDT.

- **CASE I** : When the core is at null position (for no displacement) then the flux linking with both the secondary windings is equal so the induced emf is equal in both the windings. So for no displacement the value of output E_o is zero as E_{s_1} and E_{s_2} both are equal. So it shows that no displacement took place.
- **CASE II** : When the core is moved to the left of null position the flux linking with secondary winding S_1 is more as compared to flux linking with S_2 . Due to this E_{s_1} will be more as that of E_{s_2} . Due to this output voltage E_o is positive and the output voltage is in phase with the primary voltage.
- **CASE III** : When the core is moved to right of Null position , the flux linking with secondary winding S_2 is more as compared to flux linking with S_1 . Due to this E_{s_2} will be more as that of E_{s_1} . Due to this output E_o will be negative and the differential output voltages are 180° out of phase with each other.

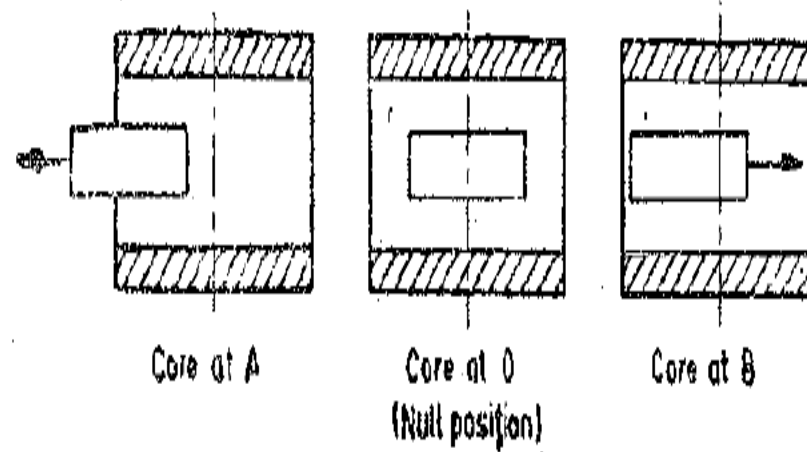
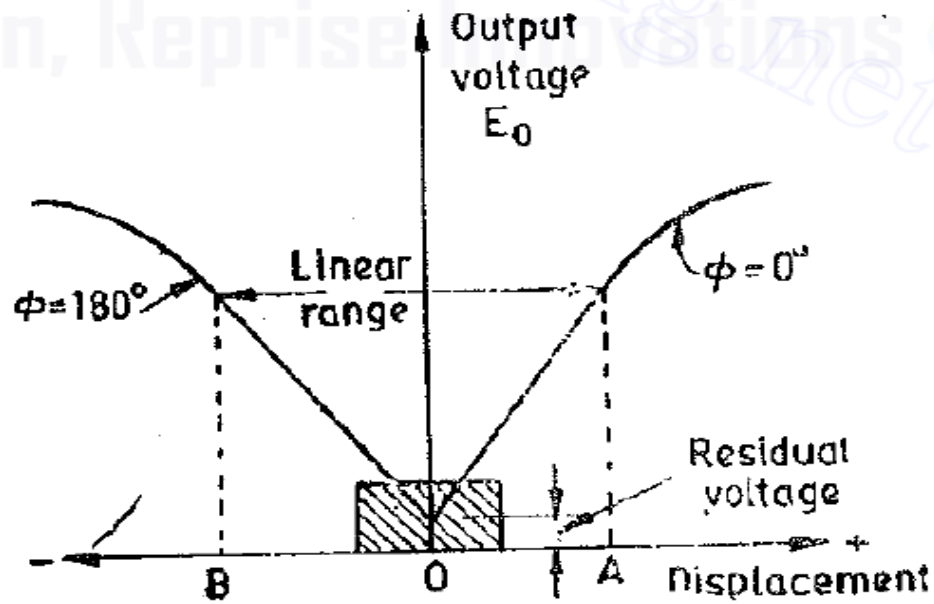
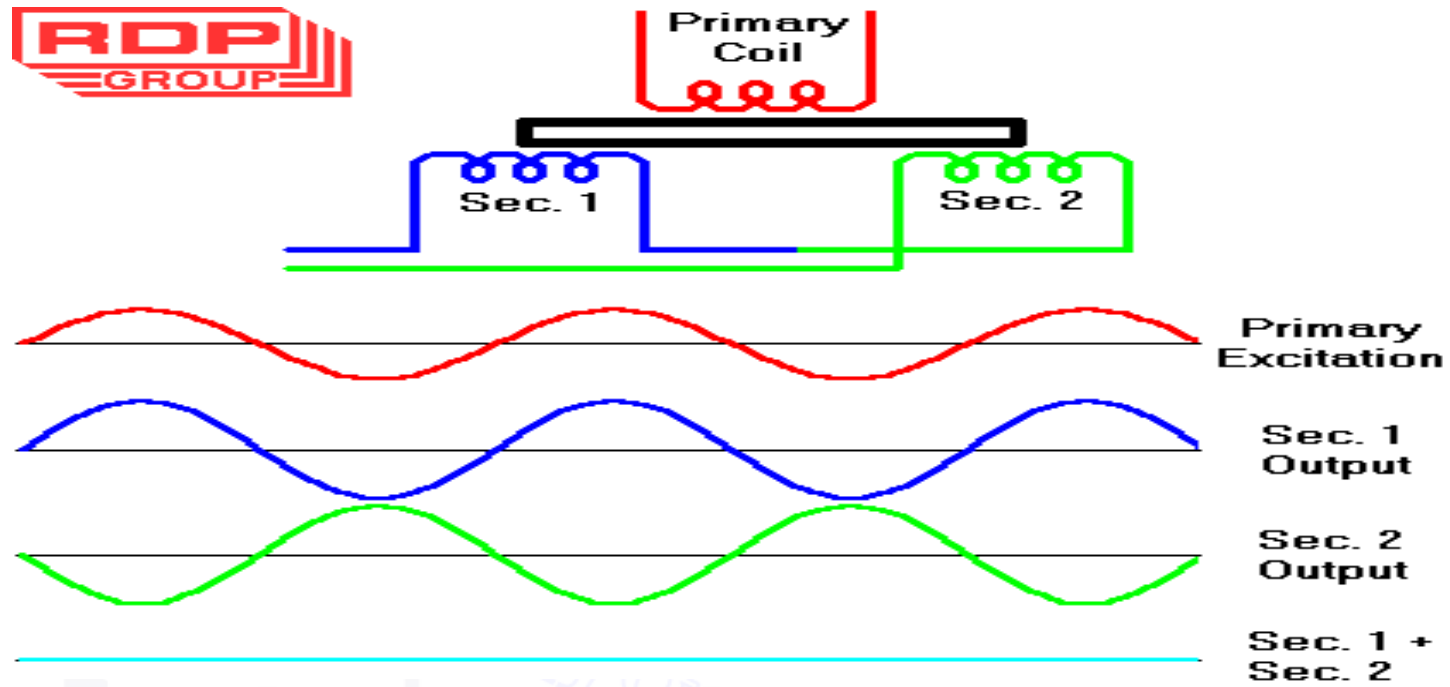

Some important points about magnitude and sign of voltage induced in LVDT

- The amount of change in voltage either negative or positive is proportional to the amount of movement of core and indicates amount of linear motion.
- By noting the output voltage increasing or decreasing the direction of motion can be determined
- The output voltage of an LVDT is linear function of core displacement .

Advantages of LVDT

- **High Range** – The LVDTs have a very high range for measurement of displacement. They can be used for measurement of displacements ranging from 1.25 mm to 250 mm
- **No Frictional Losses** – As the core moves inside a hollow former so there is no loss of displacement input as frictional loss so it makes LVDT as a very accurate device.
- **High Input and High Sensitivity** – The output of LVDT is so high that it doesn't need any amplification. The transducer possesses a high sensitivity which is typically about 40V/mm.
- **Low Hysteresis** – LVDTs show a low hysteresis and hence repeatability is excellent under all conditions
- **Low Power Consumption** – The power is about 1W which is very low as compared to other transducers.
- **Direct Conversion to Electrical Signals** – They convert the linear displacement to electrical voltage which are easy to process

Disadvantages of LVDT:

- Relatively large displacements are required for appreciable differential output.
- LVDT is sensitive to stray magnetic fields so it always requires a setup to protect them from stray magnetic fields.
- LVDT gets affected by vibrations and temperature.

Applications :

1. It can measure a displacement ranging from few mm to cm
2. Acting as a secondary transducer, LVDT can be used as a device to measure force, weight and pressure. The force or pressure to be measured is first converted into a displacement using primary transducer. Then this displacement is applied to LVDT to get the proportional output voltage.

**Piezoelectric transducer ,
Hall effect transducer**

Piezoelectric transducer

- Piezoelectric transducer is an electrical transducer which can convert any form of physical quantity into an electrical signal.
- It is used for measuring the physical quantity like force, pressure, stress, etc., which is not possible to measure directly.
- The piezoelectric transducer uses the piezoelectric material which has a special property, i.e. the material induces voltage when the pressure or stress applied to it. The material which shows such property is known as the electro-resistive element.
- The common piezoelectric material include Rochelle salt, ammonium dihydrogen phosphate, lithium sulphate, dipotassium tatarate, potassium dihydrogen phosphate, quartz and ceramics A and B.

Piezoelectric transducer

- The word piezoelectric means the electricity produces by the pressure.
- The Quartz is the examples of the natural piezoelectric crystals, whereas the Rochelle salts, ammonium dehydration, phosphate, lithium sulphate, dipotassium tartrate are the examples of the man made crystals. The ceramic material is also used for piezoelectric transducer.
- **Quartz** is a highly stable crystal which is naturally available but it has small output levels. Slowly varying parameters can be measured with quartz.
- **Rochelle salt** gives the highest output values but it is sensitive to environmental conditions and cannot be operated above 1150F.

Piezoelectric transducer

- The **ceramic** material does not have the piezoelectric property. The property is developed on it by special polarizing treatment. The ceramic material has several advantages.
- It is available in different shapes and sizes. The material has the capability of working at low voltages, and also it can operate at the temperature more than 3000°C
- The following are the properties of the Piezoelectric Crystals.
 - The piezoelectric material has high stability.
 - It is available in various shapes and sizes.
 - The piezoelectric material has output insensitive to temperature and humidity.

Piezoelectric Transducer Working

- **Piezoelectric Transducer** works with the principle of piezoelectricity. The faces of piezoelectric material, usual quartz, is coated with a thin layer of **conducting material such as silver**. When stress has applied the ions in the material move towards one of the conducting surface while moving away from the other. This results in the generation of charge.
- This charge is used for calibration of stress. The polarity of the produced charge depends upon the direction of the applied stress. Stress can be applied in two forms as **Compressive stress** and **Tensile stress** as shown below.

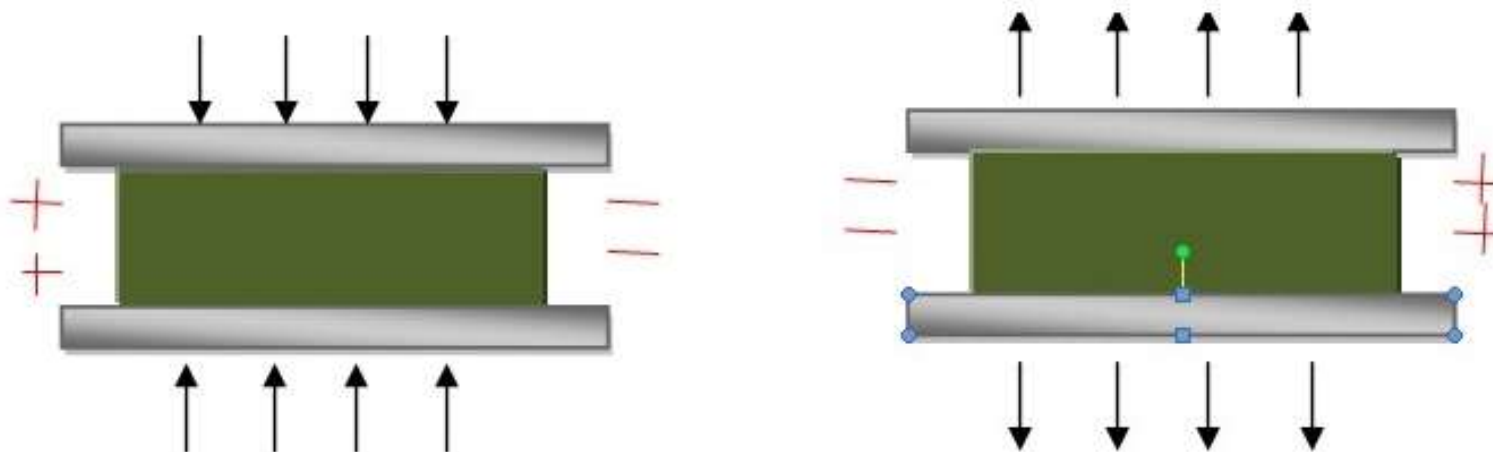

Piezoelectric Transducer Working

- Crystal in a transducer can be arranged in **longitudinal position** or **transverse position**.

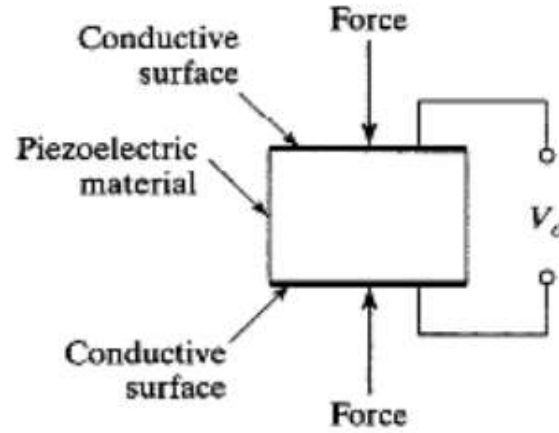

fig: Long

- The arrangement shown in the above figure is called longitudinal effect. For this arrangement, the charge generated is given by

$$Q = F \times d$$

where,

F is the applied force

d is the piezoelectric coefficient of the material.

Piezoelectric Transducer Working

- The piezoelectric coefficient, d , depends on the piezoelectric material and its crystal orientation relative to the force, F .
- For a typical quartz element, d has a value of 2.3×10^{-12} C/N.
- The above equation shows that the charge is proportional to the applied force which can also be viewed as being proportional to the displacement.
- The piezoelectric element is slightly flexible, and the imposition of a force produces a small, proportional displacement.

Piezoelectric Transducer Working

- Another configuration of the piezoelectric sensor is called transverse effect which is shown below.
- The charge generated in this configuration is given by

$$Q = F \times d \times (b/a)$$

- If the ratio of the dimensions, b/a , is greater than one (the usual case), the transverse effect produces a greater charge than the longitudinal effect.

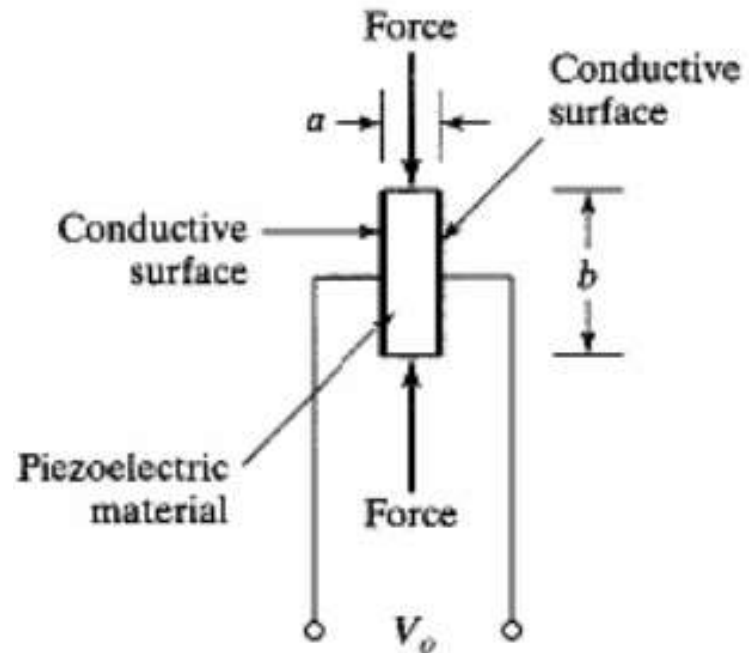

Piezoelectric Transducer Working

- With either loading, the charge is proportional to the applied force.
- This charge results in a voltage. However, this voltage depends not only on the capacitance of the piezoelectric element but also on the capacitances of the lead wires and the signal-conditioner input.

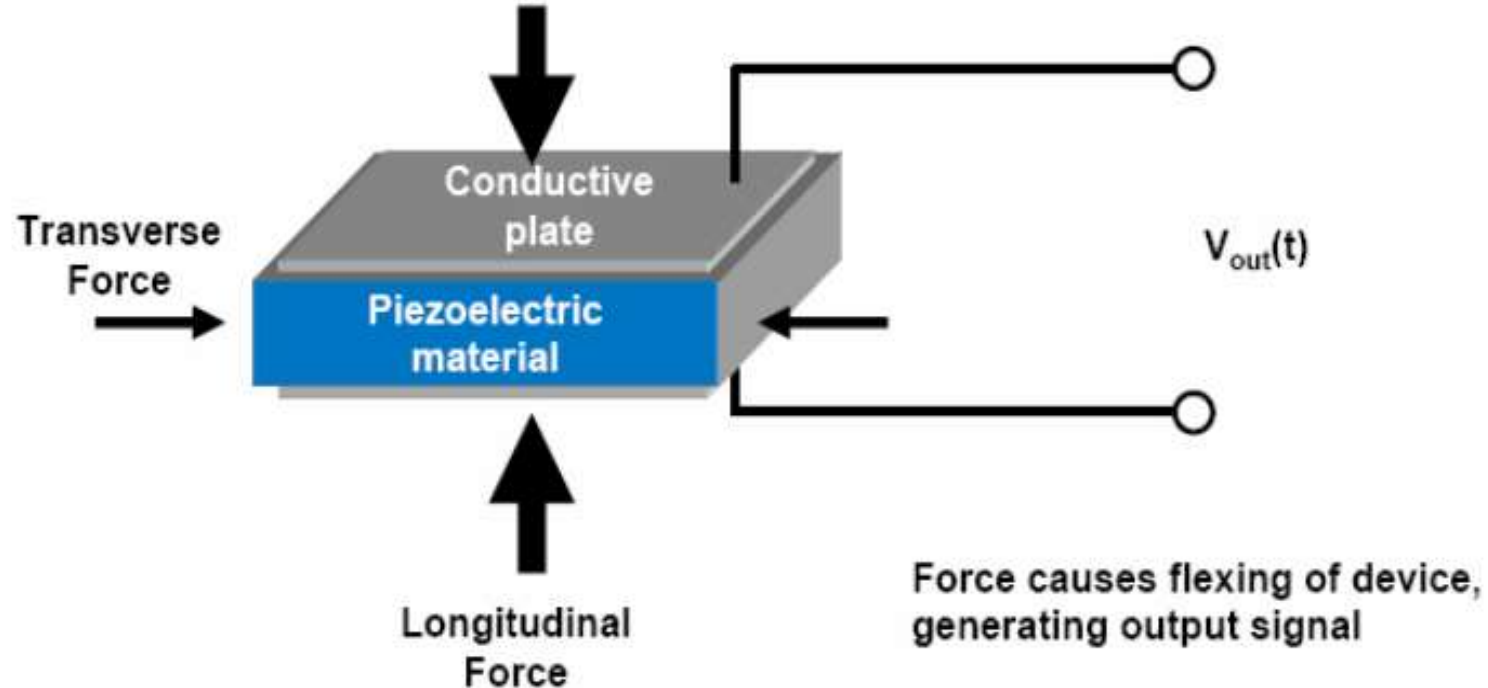

Advantages :

- Very high frequency response.
- Self generating, so no need of external source.
- Simple to use as they have small dimensions and large measuring range.
- Barium titanate and quartz can be made in any desired shape and form. It also has a large dielectric constant. The crystal axis is selectable by orienting the direction of orientation.

Disadvantages:

- Temperature and environmental conditions can affect the behavior of the transducer.
- It is not suitable for measurement in static condition.
- The relative humidity rises above 85% or falls below 35%, its output will be affected. If so, it has to be coated with wax or polymer material.

Applications:

- In microphones, the sound pressure is converted into an electric signal and this signal is ultimately amplified to produce a louder sound.
- Automobile seat belts lock in response to a rapid deceleration is also done using a piezoelectric material.
- It is also used in medical diagnostics.
- It is used in electric lighter used in kitchens. The pressure made on piezoelectric sensor creates an electric signal which ultimately causes the flash to fire up.
- They are used for studying high-speed shock waves and blast waves.
- Used infertility treatment.
- Used in Inkjet printers
- It is also used in restaurants or airports where when a person steps near the door and the door opens automatically. In this, the concept used is when a person is near the door pressure is exerted person weight on the sensors due to which the electric effect is produced and the door opens automatically.

UNIT – V

Optical encoder type digital transducer

Introduction

- In modern PC based automation systems, it is necessary to connect the output of the transducer to the computer. For this connectivity the output of the transducer must be in digital form.
- Transducers available at large are primary analogue at nature, and some form of conversion is needed to convert to transform them into digital form.
- Analogue transducers with A/D convertors can serve the purpose of digital transducers
- Few transducers are available which give digital output. Therefore the transducers which provide **digital output** is called as **Digital transducers**. They can be directly interfaced with a digital computer.
- The available digital transducers are in the form of linear or rotary displacement transducers

Introduction

- Digital transducers are called **Encoders**. They are also called digitizer as they convert continuous analog signal into binary or decimal point.
- Digital encoding transducers or **digitizers** enable linear or rotary displacement to be directly converted into digital form without intermediate ADC . Such digitiser is known as digital encoder or linear digitiser or for rotary application shaft digitiser or shaft encoder.
- Mechanical disks (or bar) with optical receivers and transmitters can act as digital displacement transducers. This type of transducers called optical encoder.
- Optical encoders can be used to measure linear and angular displacements. Therefore, optical encoders can be classified as:
 - Rotary encoders
 - Linear encoders

Optical Linear Encoder

- Encoder can be constructed as
 - (i) Contacting type
 - (ii) Non-contacting type.
- **Contacting or Brush type(Resistive encoders)**
 - The shaded areas are made of conducting material and the unshaded areas are made of non conducting material.
 - Brushes are placed on the transducer which acts as sliding contacts.
 - The circuit of sliding contacts, which come in contact with conducting areas are completed, which makes in contact with insulating area are not completed.
 - Thus the encoder gives out a digital readout which is an indication of position and hence the encoder determines the displacement.

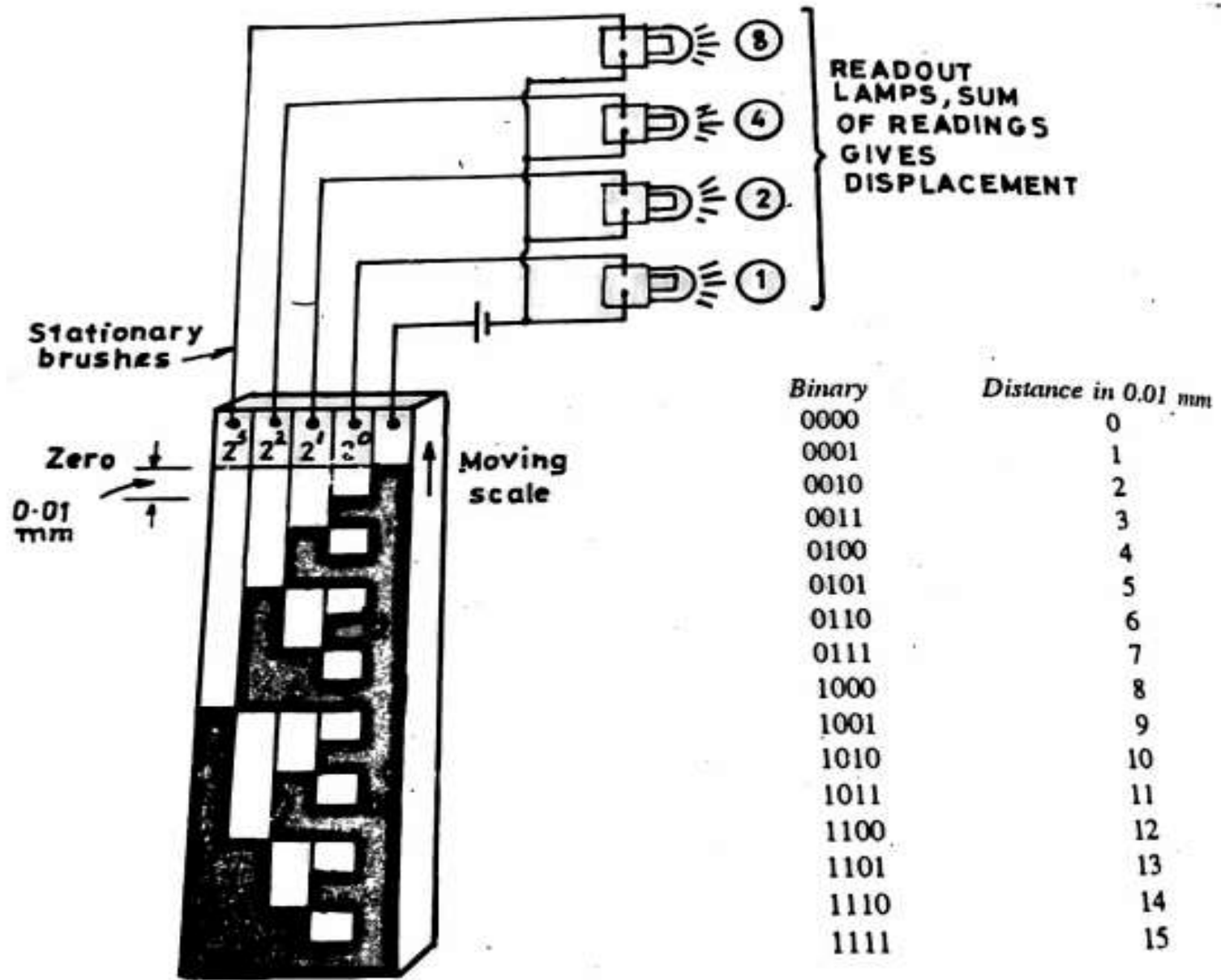

Fig: Translational encoder

- The voltages on the four lamps lines could be sent to a digital computer directly.
- If a visual readout were desired, these four voltages would be applied to a binary to decimal conversion module and then the readout decimally on a display.

Advantages:

- It is relatively inexpensive
- It can be made to any degree of desired accuracy provided that the sector is made large enough to accommodate the required number of rows for binary numbers and are quite adequate for slowly moving system .

Disadvantages:

- Major problem with these encoders is on account of wear of contactors and maintenance of contacts.

Optical Rotary Encoder

- An optical rotary encoder produces angular position data directly in digital form, eliminating any need for the ADC converter. The concept is illustrated in following figure, which shows a slotted disk attached to a shaft. A light source (LED) and light receiver (phototransistor or photodiode) arrangement are mounted so that the slots pass the light beam as the disk rotates. The angle of the shaft is deduced from the output of the photocell.
- There are two types of optical rotary encoders:
 - the absolute encoder
 - the incremental encoder

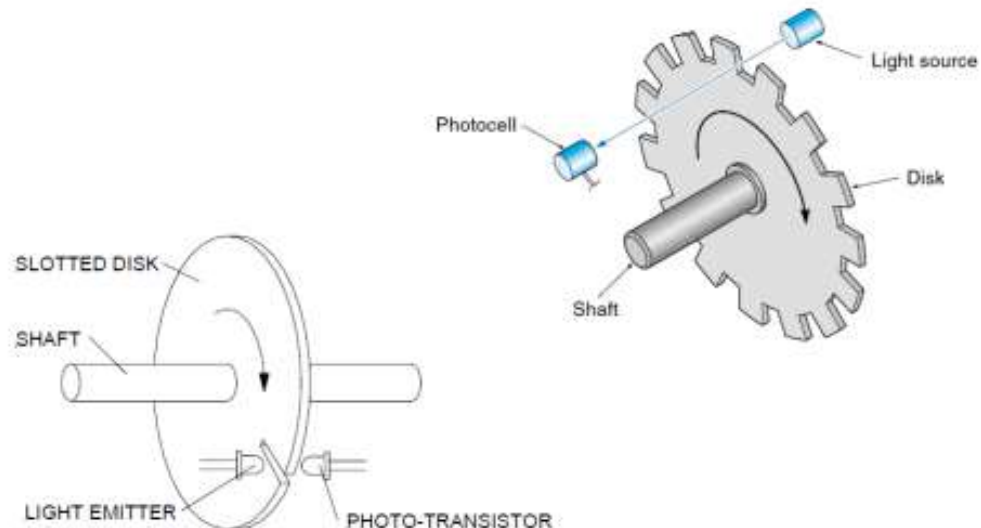

- **Absolute Rotary Encoder**

- The output of the absolute rotary encoder is in the form of a binary word which is proportional to the angle of the shaft.
- The absolute encoder does not need to be homed because when it is energized, it simply outputs the shaft angle as a digital value.
- Absolute optical encoders use a glass or plastic disk marked off with a pattern of concentric tracks as shown in the figure.
- A separate light beam is sent through each track to individual photo sensors. Each photo sensor contributes 1 bit to the output digital word.
- The encoder in the figure outputs a 4-bit word with the LSB coming from the outer track (note that this is for illustrative purposes only and a 4-bit encoder is of little practical use). The disk is divided into 16 sectors, so the resolution in this case is $360^\circ/16 = 22.5^\circ$.

- **Absolute Rotary Encoder**

- The absolute angle of the encoder shaft can be found by multiplying the binary output of the encoder times the resolution. For example, assume our 4-bit encoder has an output of 1101 (decimal 13). The encoder shaft would therefore be at an angle of $13 \times 22.5 \text{ degrees} = 292.5 \text{ degrees}$. Because of the relatively poor resolution of this encoder, the shaft could be at some angle between 292.5 degrees and $292.5 + 22.5 \text{ degrees}$.
- For better resolution, more tracks would be required. For example, eight tracks (providing 256 states) yield $360^\circ / 256 = 1.4^\circ / \text{state}$, and ten tracks (providing 1024 states) yield $360^\circ / 1024 = 0.35^\circ / \text{state}$.

Absolute Rotary Encoder

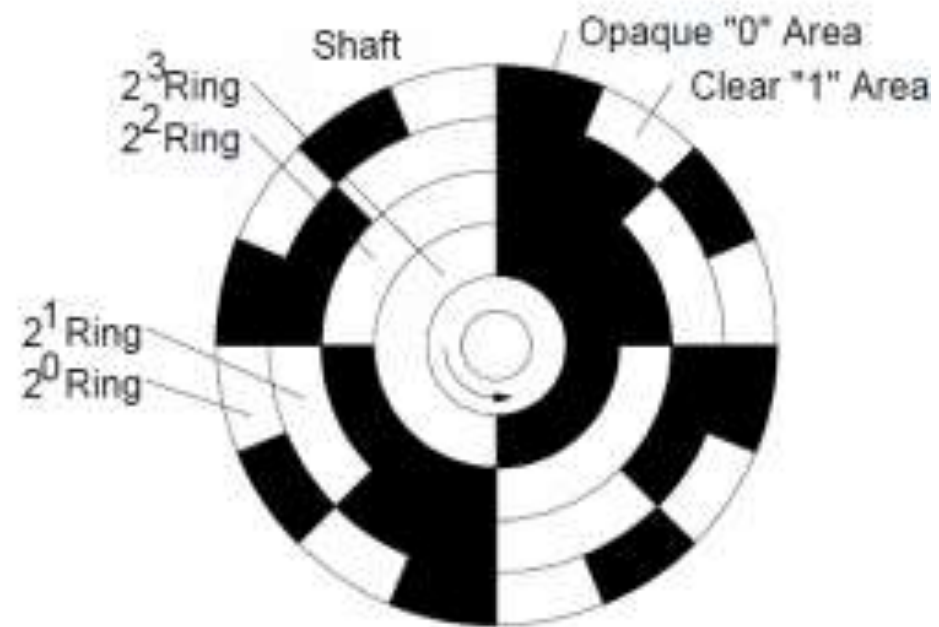
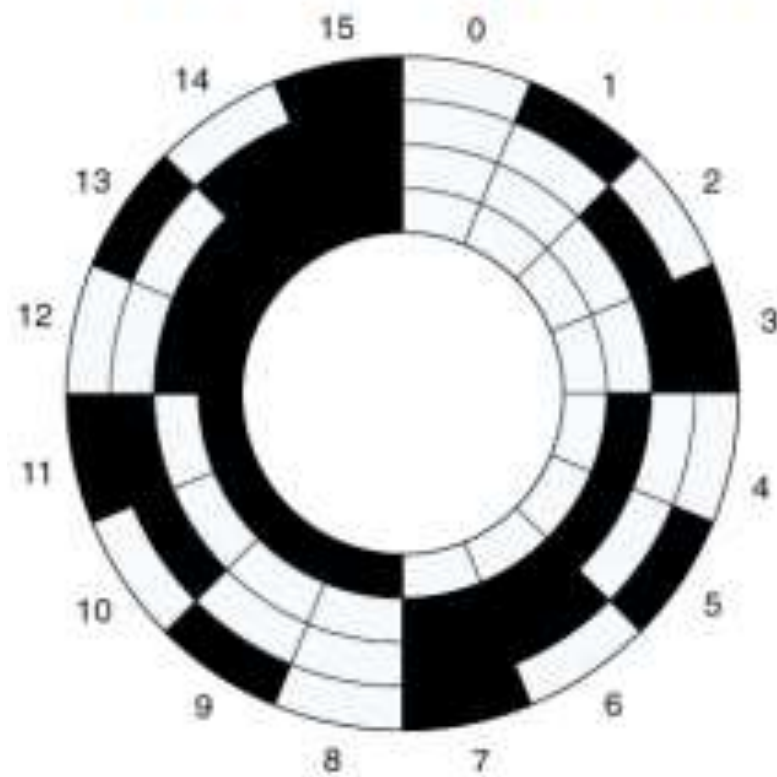

- **Absolute Rotary Encoder**

- An **advantage** of this type of encoder is that the output is in straightforward digital form and, like a pot, always gives the absolute position. This is in contrast to the incremental encoder that, as will be shown, provides only a relative position.
- A **disadvantage** of the absolute encoder is that it is relatively expensive because it requires that many photocells be mounted and aligned very precisely

***DIGITAL STORAGE
OSCILLOSCOPE (DSO)***

Digital Storage Oscilloscope

Disadvantages of analog storage CRT

- i) The waveform can be preserved for finite amount of time only and eventually the waveform will be lost.
- ii) As long as image is required to be stored, the power must be supplied to the tube.
- iii) The trace obtained from the storage tube is not fine as compared to the conventional oscilloscope tube.
- iv) The writing rate of storage tube is less than that of conventional cathode ray tube. This limits the speed of the storage tube.
- v) The storage cathode ray tube is very much expensive than conventional cathode ray tube.
- vi) The storage cathode ray tube requires additional power supplies.
- vii) Only one waveform can be stored in storage tube. If two traces are to be compared, they are required to be superimposed on the same screen and must be displayed together.
- viii) The stored waveform cannot be reproduced on the external device like computer.

BLOCK DIAGRAM

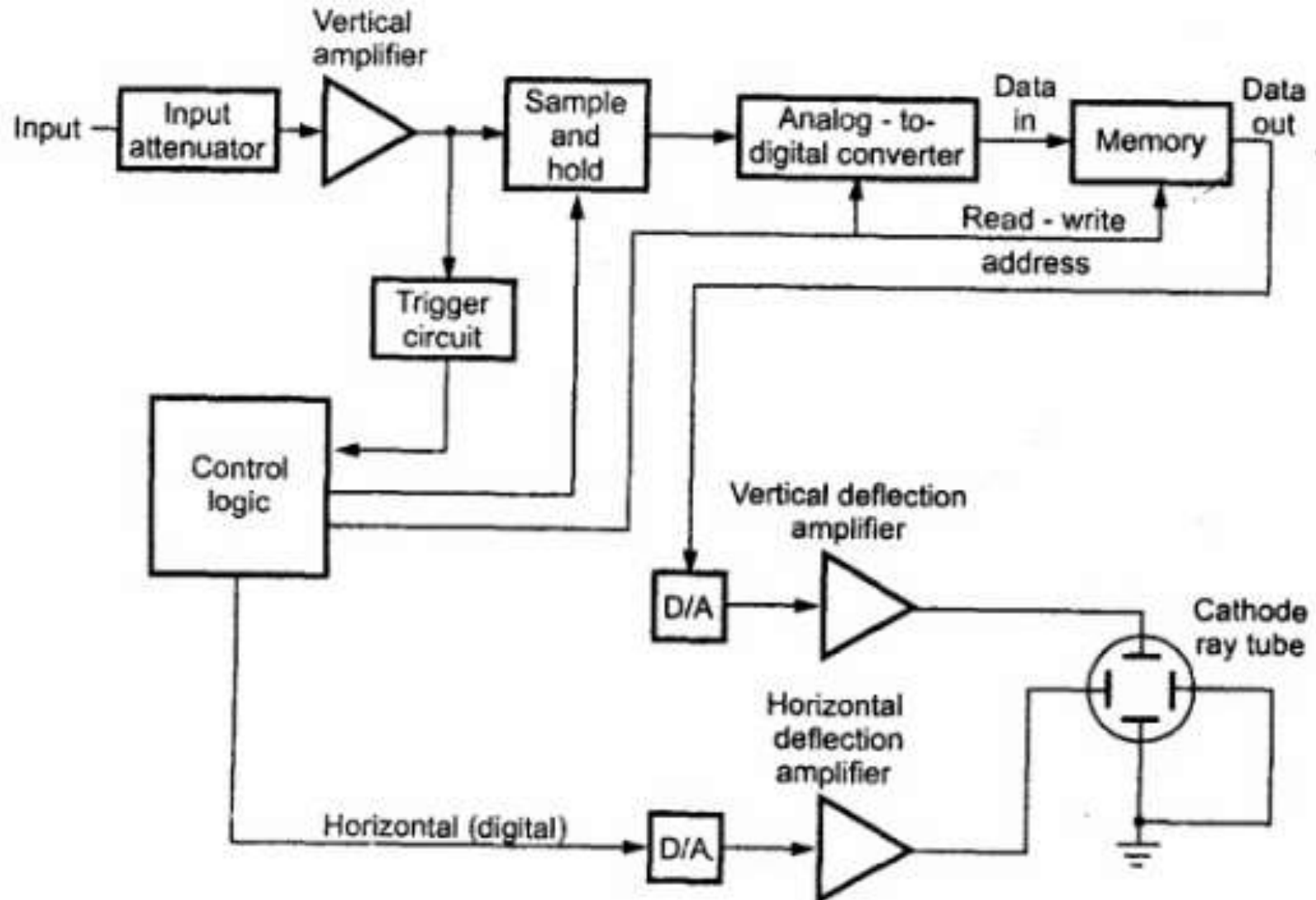

The input signal is applied to the amplifier and attenuator section.

➤ The oscilloscope uses same type of amplifier and attenuator circuitry as used in the conventional oscilloscopes.

➤ The attenuated signal is then applied to the vertical amplifier.

➤ To digitize the analog signal, analog to digital (A/D) converter is used.

➤ The output of the vertical amplifier is applied to the A/D converter section.

➤ The successive approximation type of A/D converter is most oftenly used in the digital storage oscilloscopes.

➤ The sampling rate and memory size are selected depending upon the duration & the waveform to be recorded.

➤ Once the input signal is sampled, the A/D converter digitizes it.

➤ The signal is then captured in the memory.

➤ Once it is stored in the memory, many manipulations are possible as memory can be readout without being erased.

- To digitize analog signal, analog to digital (A/D) converter is used.
- Digitizing means taking samples at periodic intervals of the input signal.
- Rate of sampling should be at least twice as fast as the highest frequency present in the input signal.
- For 12-bit converter, 0.025% resolution is obtained.
10 –bit ADC , 0.01% resolution and freq response of 25kHz is obtained .
- Total digital storage capacity is 4096 for a single channel, 2048 for two channels and 1024 for four channels.
- Once input is sampled, ADC digitize it. Signal is captured in memory. It can be used for many manipulations

Modes of operation

- One important feature of DSO is its mode of operation called **Pretrigger** view.
- Modes means that the oscilloscope can display what happened before a trigger input is applied.
- Single shot events, such as the waveform of an explosion are transient in nature and very quickly lost.
- Such events are stored in memory of DSO

Three modes of operation :

- **1.Roll Mode:** Very fast varying signals are displayed in this mode. The input signal is not triggered at all. Fast varying signal is displayed as if changing slowly, on the screen in this mode.

Store Mode

This is most commonly used and called **refresh mode**.

In this mode, the input initiates a trigger circuit. This initiates the memory write cycle. The digital data is transferred to the memory. When the memory is full, the write cycle stops.

Using digital to analog converter, the memory data is converted to analog and then displayed on the screen.

When the next trigger occurs the memory is refreshed.

Hold or Save Mode

This is called **automatic refresh mode**. When new sweep signal is generated by time base generator, the old contents get overwritten by new one.

If a particular signal is to be stored then by pressing hold or save button, overwriting can be stopped and previously saved signal is locked.

Advantages of DSO

- It is easier to operate and has more capability.
- The storage time is infinite.
- The display flexibility is available. The number of traces that can be stored and recalled depends on the size of the memory.
- The cursor measurement is possible.
- The characters can be displayed on screen along with the waveform which can indicate waveform information such as minimum, maximum, frequency, amplitude etc.
- The X-Y plots, B-H curve, P-V diagrams can be displayed.
- The pretrigger viewing feature allows to display the waveform before trigger pulse.
- Keeping the records is possible by transmitting the data to computer system where the further processing is possible
- Signal processing is possible which includes translating the raw data into finished information e.g. computing parameters of a captured signal like r.m.s. value, energy stored etc.

Acquisition methods

- In DSO it is necessary to capture the digital signal and store it.

There are three different acquisition methods used in DSO.

1. Real time sampling

2. Random repetitive sampling.

3. Sequential repetitive sampling.

Real time sampling

- In response to single trigger event, the complete record of n_m samples is simultaneously captured on each and every channel.
- Three important features of this method:
 1. Display and analysis of waveform can be carried out at later stage while the signal gets recorded in memory at an earlier stage.
 2. Very easy to capture the signals that happen before the trigger event.
 3. Simultaneous capture of multiple signals is automatic.

Random repetitive sampling.

- Repeated real time data acquisition cycles are performed. Still each value is plotted independently on display as a dot.
- Each acquisition cycle produces random time interval t_d between trigger point and sample clock.
- Time between the samples from that capture is t_s with an offset of t_d from the trigger point.
- Disadvantage of this method is that the abilities to capture a nonrecurring transient is lost.

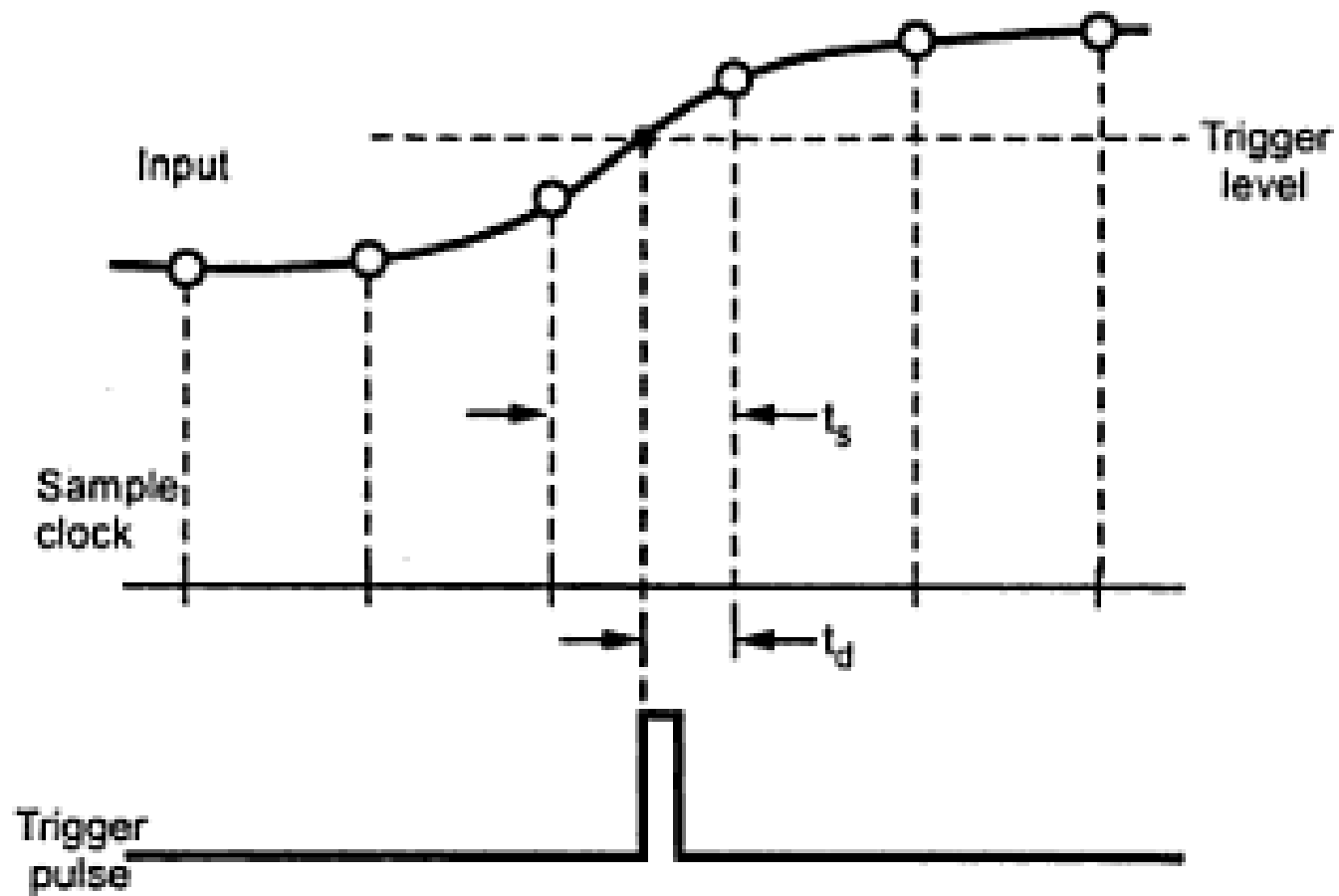

Random repetitive sampling

Sequential repetitive sampling.

- Oscilloscopes having bandwidth 20 to 50GHz need very fast sweep speed settings. Hence sequential repetitive sampling is used.
- In this method one sample value per trigger event is captured at controlled time delay t_{ds} after the triggering pulse.
- This delay is increased by small amount t_{se} after each point is captured. This increase in delay is the effective sample time.
- This method cannot capture trigger event pretrigger information.
- Major disadvantage of this method is pretrigger view feature gets lost. Hence this method is used only in microwave bandwidth digital oscilloscopes.

