

UNIT – I CIRCUIT BREAKERS

Fundamentals of Power System Protection

The purpose of an Electric Power System is to generate and supply electrical energy to consumers. The power system should be designed and managed to deliver this energy to the utilization points with both reliability and economically

The capital investment involved in power system for the generation, transmission and distribution is so great that the proper precautions must be taken to ensure that the equipment not only operates as nearly as possible to peak efficiency, but also must be protected from accidents

The normal path of the electric current is from the power source through copper (or aluminium) conductors in generators, transformers and transmission lines to the load and it is confined to this path by insulation. The insulation, however, may break down, either by the effect of temperature and age or by a physical accident, so that the current then follows an abnormal path generally known as Short Circuit or Fault

Any abnormal operating state of a power system is known as FAULT. Faults in general consist of short circuits as well as open circuits. Open circuit faults are less frequent than short circuit faults, and often they are transformed in to short circuits by subsequent events.

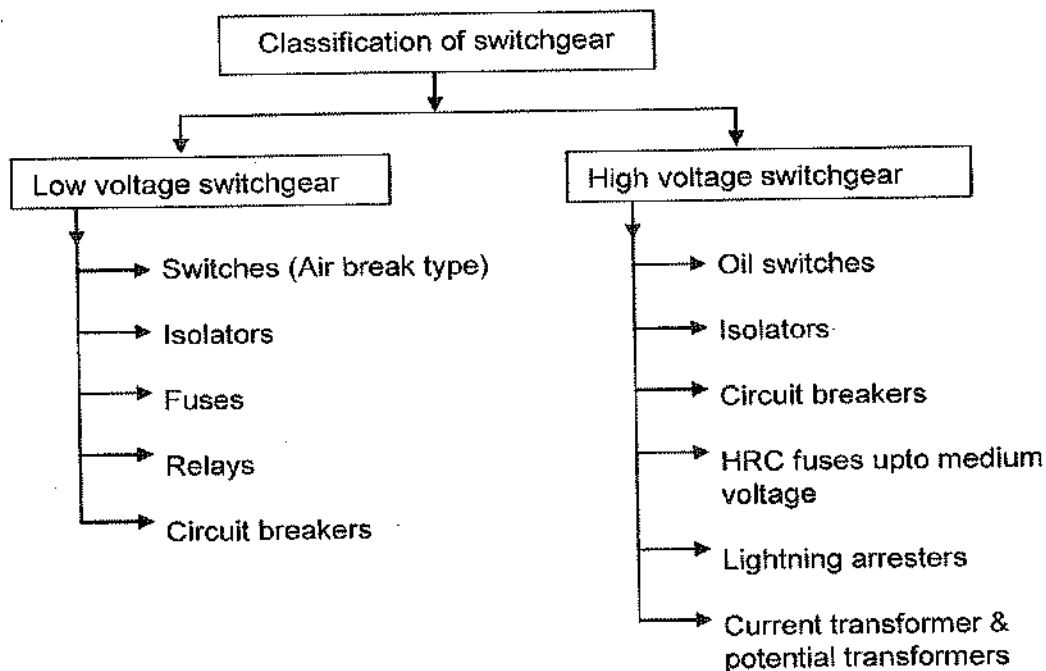

Consequences of occurrence of Faults

Faults are of two types

- Short circuit fault- current
- Open circuit fault- voltage

In terms of seriousness of consequences of a fault , short circuits are of far greater concern than open circuits, although some open circuits present some potential hazards to personnel

Classification of short circuited Faults

- Three phase faults (with or without earth connection)
- Two phase faults (with or without earth connection)
- Single phase to earth faults

- Single Phase open Circuit
- Two phase open circuit
- Three phase open circuit

Consequences

- Damage to the equipment due to abnormally large and unbalanced currents and low voltages produced by the short circuits
- Explosions may occur in the equipments which have insulating oil, particularly during short circuits. This may result in fire and hazardous conditions to personnel and equipments
- Individual generators with reduced voltage in a power station or a group of generators operating at low voltage may lead to loss of synchronism, subsequently resulting in islanding.
- Risk of synchronous motors in large industrial premises falling out of step and tripping out.

The general layout of a protection system may be viewed as given in the following figure

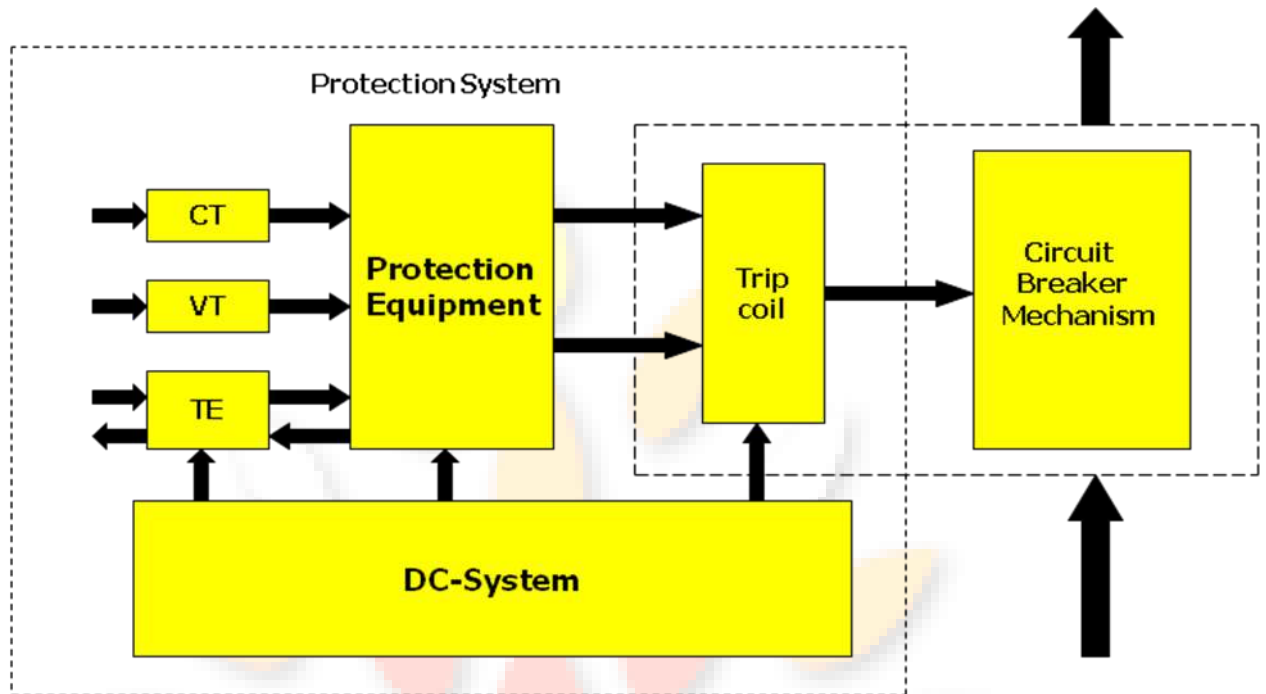

Zones and types of Protection system

Zones of Protection system

- An electric power system is divided into several zones of protection. Each zone of protection, contains one or more components of a power system in addition to two circuit breakers.
- When a fault occurs within the boundary of a particular zone, then the protection system responsible for the protection of the zone acts to isolate (by tripping the Circuit Breakers) every equipment within that zone from the rest of the system.
- The circuit Breakers are inserted between the component of the zone and the rest of the power system. Thus, the location of the circuit breaker helps to define the boundaries of the zones of protection.
- Different neighboring zones of protection are made to overlap each other, which ensure that no part of the power system remains without protection. However, occurrence of the fault with in the overlapped region will initiate a tripping sequence of different circuit breakers so that the minimum necessary to disconnect the faulty element

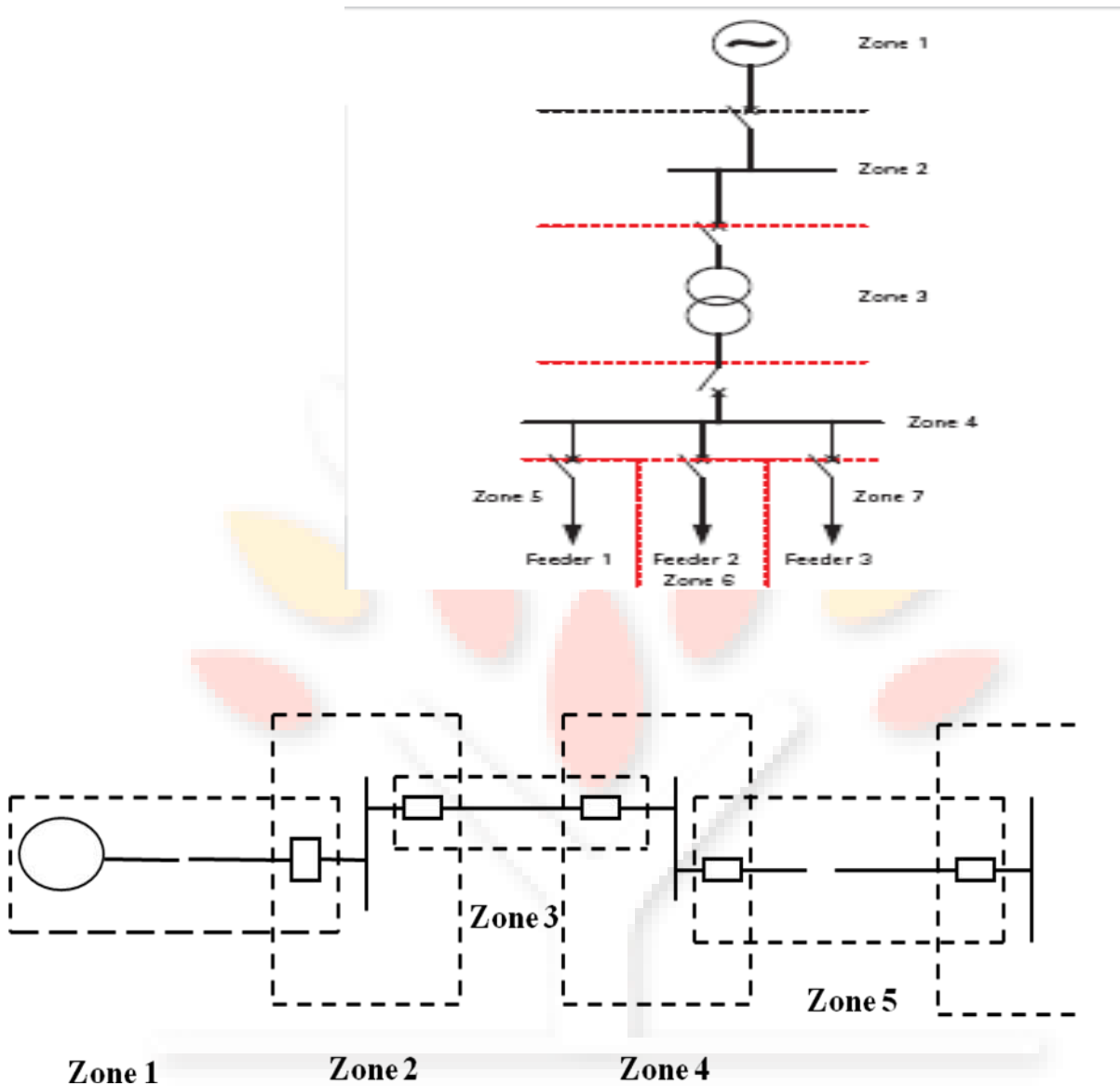

Types of Protection (Primary and Back-up Protection)

Primary Protection

The primary protection scheme ensures fast and selective clearing of any fault within the boundaries of the circuit element, that the zone is required to protect. Primary Protection as a rule is provided for each section of an electrical installation.

However, the primary protection may fail. The primary cause of failure of the Primary Protection system are enumerated below.

- Current or voltage supply to the relay.
- D.C. tripping voltage supply

- Protective relays
- Tripping circuit
- Circuit Breaker

Back-up Protection

Back-up protection is the name given to a protection which backs the primary protection whenever the later fails in operation. The back-up protection by definition is slower than the primary protection system. The design of the back-up protection needs to be coordinated with the design of the primary protection and essentially it is the second line of defence after the primary protection system.

Protection System Requirements and some basic terminologies used

The fundamental requirements for a protection system are as follows:

Reliability: It is the ability of the protection system to operate correctly. The reliability feature has two basic elements, which are *dependability* and *security*. The dependability feature demands the certainty of a correct operation of the designed system, on occurrence of any fault. Similarly, the security feature can be defined as the ability of the designed system to avoid incorrect operation during faults. A comprehensive statistical method based reliability study is required before the protection system may be commissioned. The factors which affect this feature of any protection system depends on some of the following few factors.

- a) Quality of Component used
- b) Maintenance schedule
- c) The supply and availability of spare parts and stocks
- d) The design principle
- e) Electrical and mechanical stress to which the protected part of the system is subjected to.

Speed: Minimum operating time to clear a fault in order to avoid damage to equipment. The speed of the protection system consists primarily of two time intervals of interest.

- *The Relay Time* : This is the time between the instant of occurrence of the fault to the instant at which the relay contacts open.
- *The Breaker Time:* This is the time between the instant of closing of relay contacts to the instant of final arc extinction inside the medium and removal of the fault.

Selectivity: This feature aims at maintaining the continuity of supply system by disconnecting the minimum section of the network necessary to isolate the fault. The property of selective tripping is also known as -discrimination|. This is the reason for which the entire system is divided into several protective zones so that minimum portion of network is isolated with accuracy. Two examples of utilization of this feature in a relaying scheme are as follows

- Time graded systems
- Unit systems

Sensitivity: The sensitivity of a relay refers to the smallest value of the actuating quantity at which the relay operates detecting any abnormal condition. In case of an overcurrent relay, mathematically this can be defined as the ratio between the short circuit fault current (I_s) and the relay operating current (I_o). The value of I_o , should not be too small or large so that the relay is either too sensitive or slow in responding.

Stability: It is the quality of any protection system to remain stable within a set of defined operating scenarios and procedures. For example the biased differential scheme of differential protection is more stable towards switching transients compared to the more simple and basic Merz Price scheme in differential protection

Adequacy: It is economically unviable to have a 100% protection of the entire system in concern. Therefore, the cost of the designed protection system varies with the criticality and importance of the protected zone. The protection system for more critical portions is generally costly, as all the features of a good protection system is maximized here. But a small motor can be protected by a simple thermally operated relay, which is simple and cheap. Therefore, the cost of the protection system should be adequate in its cost.

Some basic terminologies used in protection system

Some basic terminologies commonly used in the protection system are enlisted below.

- i) Measuring Relay
- ii) Fault Clearing Time
- iii) Auxiliary relay
- iv) Relay Time
- v) Pick up value
- vi) Reset Value

- vii) Drop out
- viii) Reach (under and over reaches)
- ix) Relay Burden
- x) Unit/ Non unit protection
- xi) All or Nothing relay

CIRCUIT BREAKER

Introduction:

During the operation of power system, it is often desirable and necessary to switch on or off the various circuits (e.g., transmission lines, distributors, generating plants etc.) under both normal and abnormal conditions. In earlier days, this function used to be performed by a switch and a fuse placed in series with the circuit. However, such a means of control presents two disadvantages.

1. Firstly, when a fuse blows out, it takes quite some time to replace it and restore supply to the customers.
2. Secondly, a fuse cannot successfully interrupt heavy fault currents that result from faults on modern high- voltage and large capacity circuits.

Due to these disadvantages, the use of switches and fuses is limited to low voltage and small capacity circuits where frequent operations are not expected e.g., for switching and protection of distribution transformers, lighting circuits, branch circuits of distribution lines etc.

With the advancement of power system, the lines and other equipment operate at very high voltages and carry large currents. The arrangement of switches along with fuses cannot serve the desired function of switchgear in such high capacity circuits. This necessitates employing a more dependable means of control such as is obtained by the use of **circuit breakers**.

A circuit breaker can make or break a circuit either manually or automatically under all conditions viz., no-load, full- load and short-circuit conditions.

This characteristic of the circuit breaker has made it very useful equipment for switching and protection of various parts of the power system.

A circuit breaker is a piece of equipment which can

- (i) Make or break a circuit either manually or by remote control under normal conditions.*

(ii) *Break a circuit automatically under fault conditions*

(iii) *Make a circuit either manually or by remote control under fault conditions*

Thus a circuit breaker incorporates manual (or remote control) as well as automatic control for switching functions. The latter control employs relays and operates only under fault conditions.

OPERATING PRINCIPLE:

A circuit breaker essentially consists of fixed and moving contacts, called Electrodes. Under normal operating conditions, these contacts remain closed and will not open automatically until and unless the system becomes faulty. Of course, the contacts can be opened manually or by remote control whenever desired. When a fault occurs on any part of the system, the trip coils of the circuit breaker get energized and the moving contacts are pulled apart by some mechanism, thus opening the circuit.

- ❖ When the contacts of a circuit breaker are separated under fault conditions, an arc is struck between them. The current is thus able to continue until the discharge ceases.
- ❖ The production of arc not only delays the current interruption process but it also generates enormous heat which may cause damage to the system or to the circuit breaker itself.
- ❖ Therefore, the main problem in a circuit breaker is to extinguish the arc within the shortest possible time so that heat generated by it may not reach a dangerous value.

Arc Phenomenon:

When a short circuit occurs, a heavy current flows through the contacts of the circuit breaker before they are opened by the protective system. At the instant when the contacts begin to separate, the contact area decreases rapidly and large fault current causes increased current density and hence rise in temperature. The heat produced in the medium between contacts (usually the medium is oil or air) is sufficient to ionize the air or vaporize and ionize the oil. The ionized air or vapor acts as conductor and an arc is struck between the contacts.

- ❖ The potential difference between the contacts is quite small and is just sufficient to maintain the arc.
- ❖ The arc provides a low resistance path and consequently the current in the circuit remains UN interrupted so long as the arc persists.
- ❖ During the arcing period, the current flowing between the contacts depends upon the arc resistance. The greater the arc resistance, the smaller the current that flows between the contacts.

The arc resistance depends upon the following factors:

1. **Degree of ionization**- the arc resistance increases with the decrease in the number of ionized particles between the contacts.

2. **Length of the arc**— the arc resistance increases with the length of the arc i.e., separation of contacts.
3. **Cross-section of arc**— the arc resistance increases with the decrease in area of X-section of the arc.

Principles of Arc Extinction:

Before discussing the methods of arc extinction, it is necessary to examine the factors responsible for the maintenance of arc between the contacts. These are:

1. Potential difference between the contacts.
 2. Ionized particles between contacts taking these in turn.
- ❖ When the contacts have a small separation, the Potential difference between them is sufficient to maintain the arc. One way to extinguish the arc is to separate the contacts to such a distance that Potential difference becomes inadequate to maintain the arc. However, this method is impracticable in high voltage system where a separation of many meters may be required.
 - ❖ The ionized particles between the contacts tend to maintain the arc. If the arc path is demonized, the arc extinction will be facilitated. This may be achieved by cooling the arc or by bodily removing the ionized particles from the space between the contacts.

Methods of Arc Extinction (or) Interruption:

There are two methods of extinguishing the arc in circuit breakers viz.

1. High resistance method.
2. Low resistance or current zero method

High resistance method:

In this method, arc resistance is made to increase with time so that current is reduced to a value insufficient to maintain the arc. Consequently, the current is interrupted or the arc is extinguished.

- ❖ The principal disadvantage of this method is that enormous energy is dissipated in the arc. Therefore, it is employed only in D.C. circuit breakers and low-capacity a.c. circuit breakers.

The resistance of the arc may be increased by:

1. **Lengthening the arc:** The resistance of the arc is directly proportional to its length. The length of the arc can be increased by increasing the gap between contacts.
2. **Cooling the arc:** Cooling helps in the deionization of the medium between the contacts. This increases the arc resistance. Efficient cooling may be obtained by a gas blast directed along the arc.

- 3. Reducing X-section of the arc:** If the area of X-section of the arc is reduced, the voltage necessary to maintain the arc is increased. In other words, the resistance of the arc path is increased. The cross-section of the arc can be reduced by letting the arc pass through a narrow opening or by having smaller area of contacts.
- 4. Splitting the arc:** The resistance of the arc can be increased by splitting the arc into a number of smaller arcs in series. Each one of these arcs experiences the effect of lengthening and cooling. The arc may be split by introducing some conducting plates between the contacts.

Low resistance or Current zero method:

In this method is employed for arc extinction in a.c. circuits only. In this method, arc resistance is kept low until current is zero where the arc extinguishes naturally and is prevented from restriking in spite of the rising voltage across the contacts. All Modern high power a.c. circuit breakers employ this method for arc extinction.

- ❖ In an a.c. system, current drops to zero after every half-cycle. At every current zero, the arc extinguishes for a brief moment.
- ❖ Now the medium between the contacts contains ions and electrons so that it has small dielectric strength and can be easily broken down by the rising contact voltage known as restriking voltage.
- ❖ If such a breakdown does occur, the arc will persist for another half cycle.
- ❖ If immediately after current zero, the dielectric strength of the medium between contacts is built up more rapidly than the voltage across the contacts, the arc fails to restrike and the current will be interrupted.

The rapid increase of dielectric strength of the medium near current zero can be achieved by:

- ❖ Causing the ionized particles in the space between contacts to recombine into neutral molecules.
- ❖ Sweeping the ionized particles away and replacing them by un ionized particles.

Therefore, the real problem in a.c. arc interruption is to rapidly de ionize the medium between contacts as soon as the current becomes zero so that the rising contact voltage or restriking voltage cannot breakdown the space between contacts.

The de-ionization of the medium can be achieved by:

- 1. Lengthening of the gap:** The dielectric strength of the medium is proportional to the length of the gap between contacts. Therefore, by opening the contacts rapidly, higher dielectric strength of the medium can be achieved.
- 2. High pressure:** If the pressure in the vicinity of the arc is increased, the density of

the particles constituting the discharge also increases. The increased density of particles causes higher rate of de-ionization and consequently the dielectric strength of the medium between contacts is increased.

3. **Cooling:** Natural combination of ionized particles takes place more rapidly if they are allowed to cool. Therefore, dielectric strength of the medium between the contacts can be increased by cooling the arc.
4. **Blast effect:** If the ionized particles between the contacts are swept away and replaced by UN ionized particles, the dielectric strength of the medium can be increased considerably. This may be achieved by a gas blast directed along the discharge or by forcing oil into the contact space.

There are two theories to explain the Zero current interruption of the Arc:

1. Recovery rate theory (Slepain_s Theory)
2. Energy balance theory (Cassie_s Theory)

Recovery rate theory (Slepain's Theory):

The arc is a column of ionized gases. To extinguish the arc, the electrons and ions are to be removed from the gap immediately after the current reaches a natural zero. Ions and electrons can be removed either by recombining them into neutral molecules or by sweeping them away by inserting insulating medium (gas or liquid) into the gap. The arc is interrupted if ions are removed from the gap recovers its dielectric strength is compared with the rate at which the restriking voltage (transient voltage) across the gap rises. If the dielectric strength increases more rapidly than the restriking voltage, the arc is extinguished. If the restriking voltage rises more rapidly than the dielectric strength, the ionization persists and breakdown of the gap occurs, resulting in an arc for another half cycle.

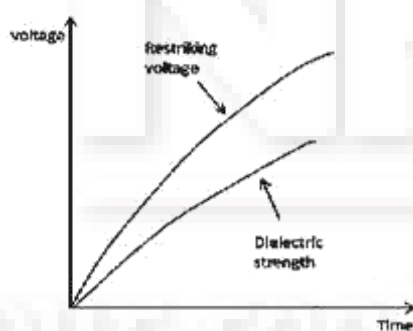

(a) Arc Extinguishes

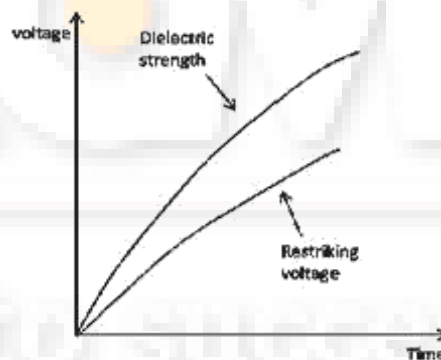

(b) Arc Persists

Energy balance theory (Cassie's Theory):

The space between the contacts contains some ionized gas immediately after current zero and hence, it has a finite post-zero moment, power is zero because restriking voltage is zero. When the arc is finally extinguished, the power gain becomes zero, the gap is fully de-ionized and its resistance is infinitely high. In between these two limits, first the power increases, reaches a maximum value, then decreases and finitely reaches zero value as shown in figure. Due to the rise of restriking voltage and associated current, energy is generated in the space between the contacts. The energy appears in the form of heat. The circuit breaker is designed to remove this generated heat as early as possible by cooling the gap, giving a blast air or flow of oil at high velocity and pressure. If the rate of removal of heat is faster than the rate of heat generation the arc is extinguished. If the rate of heat generation is more than the rate of heat dissipation, the space breaks down again resulting in an arc for another half cycle.

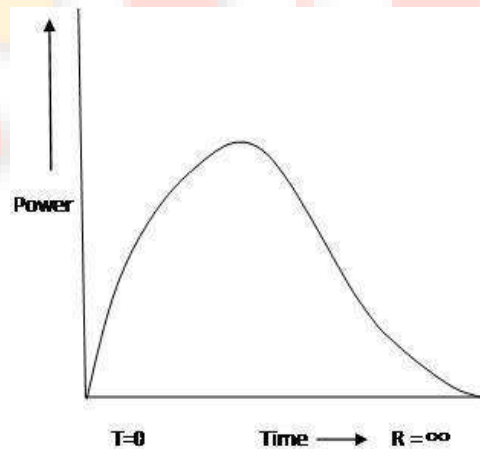

Important Terms:

The following are the important terms much used in the circuit breaker analysis:

1. Arc Voltage:

It is the voltage that appears across the contacts of the circuit breaker during the arcing period. As soon as the contacts of the circuit breaker separate, an arc is formed. The voltage that appears across the contacts during arcing period is called the arc voltage. Its value is low except for the period the fault current is at or near zero current point. At current zero, the arc voltage rises rapidly to peak value and this peak voltage tends to maintain the current flow in the form of arc.

2. Restriking voltage:

It is the transient voltage that appears across the contacts at or near current zero

during arcing period. At current zero, a high-frequency transient voltage appears across the contacts and is caused by the rapid distribution of energy between the magnetic and electric fields associated with the plant and transmission lines of the system. This transient voltage is known as **restriking voltage** (Fig. 19.1).

The current interruption in the circuit depends upon this voltage. If the restriking voltage rises more rapidly than the dielectric strength of the medium between the contacts, the arc will persist for another half-cycle. On the other hand, if the dielectric strength of the medium builds up more rapidly than the restriking voltage, the arc fails to restrike and the current will be interrupted.

3. Recovery voltage:

It is the normal frequency (50 Hz) R.M.S. voltage that appears across the contacts of the circuit breaker after final arc extinction. It is approximately equal to the system voltage.

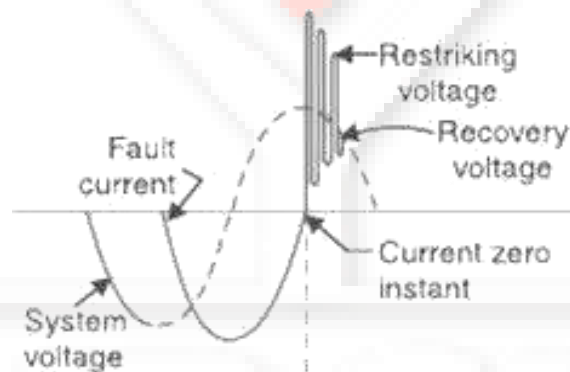

Fig. 19.1

When contacts of circuit breaker are opened, current drops to zero after every half cycle. At some current zero, the contacts are separated sufficiently apart and dielectric strength of the medium between the contacts attains a high value due to the removal of ionized particles. At such an instant, the medium between the contacts is strong enough to prevent the breakdown by the restriking voltage. Consequently, the final arc extinction takes place and circuit current is interrupted. Immediately after final current interruption, the voltage that appears across the contacts has a transient part (See Fig.19.1). However, these transient oscillations subside rapidly due to the damping effect of system resistance and normal circuit voltage appears across the contacts. The voltage across the contacts is of normal frequency and is known as recovery voltage.

Expression for Restriking voltage and RRRV:

The power system contains an appreciable amount of inductance and some capacitance. When a fault occurs, the energy stored in the system can be considerable. Interruption of fault current by a circuit breaker will result in most of the stored energy dissipated within the circuit breaker, the remainder being dissipated during oscillatory surges in the system. The oscillatory surges are undesirable and, therefore, the circuit breaker must be designed to dissipate as much of the stored energy as possible.

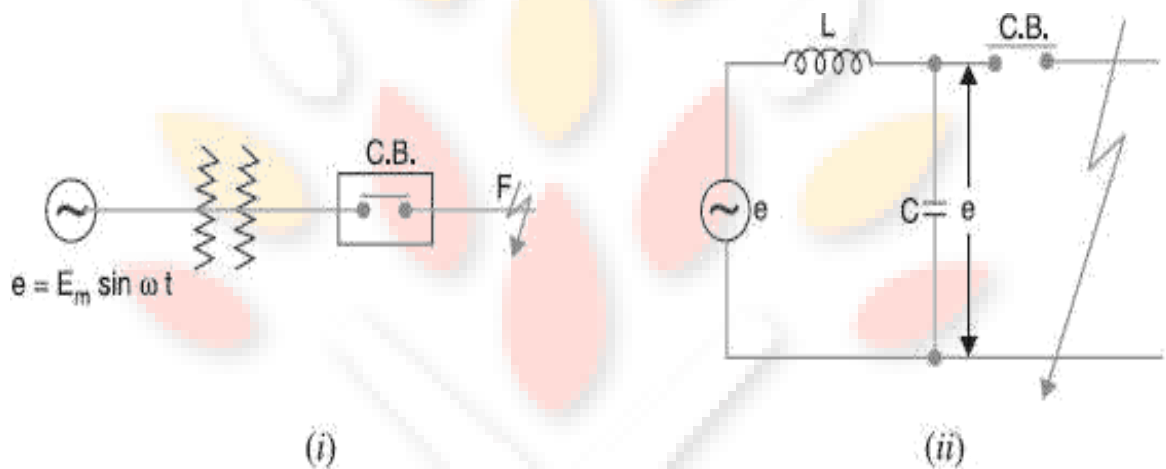

Fig. 19.17

Fig. 19.17 (i) shows a short-circuit occurring on the transmission line. Fig 19.17 (ii) shows its equivalent circuit where L is the inductance per phase of the system up to the point of fault and C is the capacitance per phase of the system. The resistance of the system is neglected as it is generally small.

Rate of rise of re-striking voltage:

It is the rate of increase of re-striking voltage and is abbreviated by R.R.R.V. usually; the voltage is in kV and time in microseconds so that R.R.R.V. is in kV/ μ sec.

Consider the opening of a circuit breaker under fault conditions Shown in simplified form in Fig. 19.17(ii) above. Before current interruption, the capacitance C is short-circuited by the fault and the short-circuit current through the breaker is limited by Inductance L of the system only. Consequently, the short-circuit current will lag the voltage by 90° as shown in Fig. 19.18, where I Represents the short-circuit current and e_a represents the arc voltage. It may be seen that in this condition, the *entire generator voltage appears across inductance L .

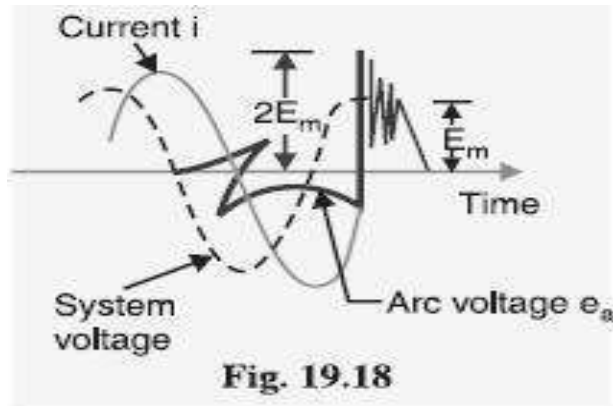

When the contacts are opened and the arc finally extinguishes at some current zero, the generator voltage e is suddenly applied to the inductance and capacitance in series.

This L - C combination forms an oscillatory circuit and produces a transient of frequency:

$$f_n = \frac{1}{2\pi} \sqrt{\frac{1}{LC}}$$

The voltage across the capacitance which is the voltage across the contacts of the circuit breaker can be calculated in terms of L, C, f_n and system voltage. The mathematical expression for transient condition is as follows.

As $v_c(t) = 0$ at $t=0$, constant = 0

$v_c(t) = E(1 - \cos \omega_n t)$ or ~~Restriking~~ Restriking voltage

The maximum value of restriking voltage = $2E_{\text{peak}} = 2 \times \text{Peak value of system voltage}$

$$\begin{aligned} \text{The rate of rise of restriking voltage (RRRV)} &= \frac{d}{dt} (1 - \cos \omega_n t) \\ &= \omega_n E \sin \omega_n t \end{aligned}$$

The maximum value of RRRV = $\omega_n E = \omega_n E_{\text{peak}}$

Which appears across the capacitor C and hence across the contacts of the circuit breaker. This transient voltage, as already noted, is known as re-striking voltage and may reach an instantaneous peak value twice the peak phase-neutral voltage i.e. $2E_m$. The system losses cause the oscillations to decay fairly rapidly but the initial overshoot increases the possibility of re-striking the arc.

It is the rate of rise of re-striking voltage (R.R.R.V.) which decides whether the arc will re-strike or not. If

R.R.R.V. is greater than the rate of rise of dielectric strength between the contacts, the arc will re-strike. However, the arc will fail to re-strike if R.R.R.V. is less than the rate of increase of dielectric strength between the contacts of the breaker.

The value of R.R.R.V. depends up on:

1. Recovery voltage
2. Natural frequency of oscillations

For a short-circuit occurring near the power station bus-bars, C being small, the natural frequency f_n will be high. Consequently, R.R.R.V. will attain a large value. Thus the worst condition for a circuit breaker would be that when the fault takes place near the bus-bars.

CURRENT CHOPPING:

It is the phenomenon of current interruption before the natural current zero is reached. Current chopping mainly occurs in air-blast circuit breakers because they retain the same extinguishing power irrespective of the magnitude of the current to be interrupted. When breaking low currents (e.g., transformer magnetizing current) with such breakers, the powerful de-ionizing effect of air-blast causes the current to fall abruptly to zero well before the natural current zero is reached. This phenomenon is known as current chopping and results in the production of high voltage transient across the contacts of the circuit breaker as discussed below:

Consider again Fig. 19.17 (ii) repeated as Fig. 19.19 (i). Suppose the arc current is i when it is chopped down to zero value as shown by point a in Fig. 19.19 (ii). As the chop occurs at current i , therefore, the energy stored in inductance is $L i^2 / 2$.

This energy will be transferred to the capacitance C, charging the latter to a prospective voltage e given by:

$$\frac{L i^2}{2} = \frac{C v^2}{2} \quad \text{(or) } v = i \sqrt{\frac{L}{C}} \text{ volts}$$

The prospective voltage e is very high as compared to the dielectric strength gained by the gap so that the breaker restrike. As the de-ionizing force is still in action, therefore, chop occurs again but the arc current this time is smaller than the previous case. This induces a lower prospective voltage to re-ignite the arc. In fact, several chops may occur until a low

enough current is interrupted which produces insufficient induced voltage to re-strike across the breaker gap. Consequently, the final interruption of current takes place.

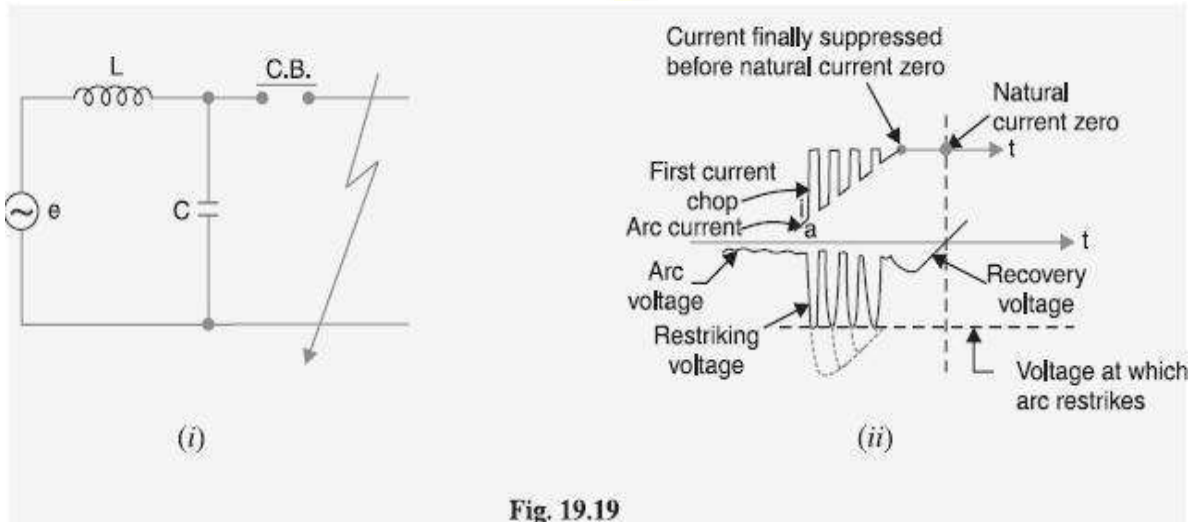

Fig. 19.19

Excessive voltage surges due to current chopping are prevented by shunting the contacts of the breaker with a resistor (resistance switching) such that re ignition is unlikely to occur. This is explained in Art 19.19.

Capacitive current breaking:

Another cause of excessive voltage surges in the circuit breakers is the interruption of capacitive currents. Examples of such instances are opening of an unloaded long transmission line, disconnecting a capacitor bank used for power factor improvement etc. Consider the simple equivalent circuit of an unloaded transmission line shown in Fig.19.20. Such a line, although unloaded in the normal sense, will actually carry a capacitive current I on account of appreciable amount of capacitance C between the line and the earth.

Let us suppose that the line is opened by the circuit breaker at the instant when line capacitive current is zero [point 1 in Fig. 19.21. At this instant, the generator voltage V_g will be maximum (i.e. V_{gm}) lagging behind the current by 90° . The opening of the line leaves a standing charge on it (i.e., end B of the line) and the capacitor C_1 is charged to V_{gm} . However, the generator end of the line (i.e., end A of the line) continues its normal sinusoidal variations. The voltage V_r across the circuit breaker will be the difference between the voltages on the respective sides. Its initial value is zero (point 1) and increases slowly in the beginning. But half a cycle later [point R in Fig. 19.21], the

potential of the circuit breaker contact A becomes maximum negative which causes the voltage across the breaker (V_r) to become $2 V_{gm}$. This voltage may be sufficient to restrike the arc. The two previously separated parts of the circuit will now be joined by an arc of very low resistance. The line capacitance discharges at once to reduce the voltage across the circuit breaker, thus setting up high frequency transient. The peak value of the initial transient will be twice the voltage at that instant i.e., $-4 V_{gm}$. This will cause the transmission voltage to swing to $-4V_{gm}$ to $+ V_{gm}$ i.e., $-3V_{gm}$.

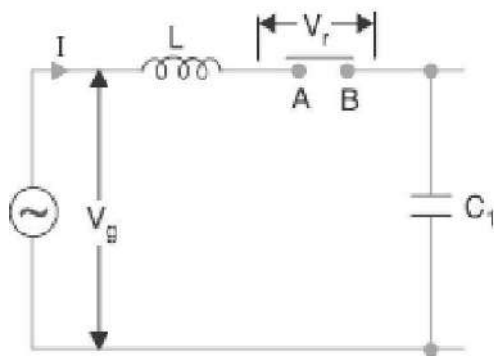

Fig. 19.20

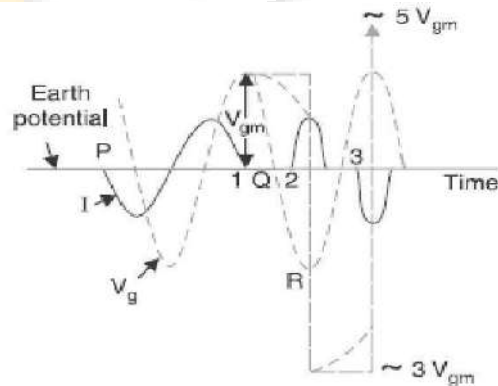

Fig. 19.21

The re-strike arc current quickly reaches its first zero as it varies at natural frequency. The voltage on the line is now $-3 V_{gm}$ and once again the two halves of the circuit are separated and the line is isolated at this potential. After about half a cycle further, the aforesaid events are repeated even on more formidable scale and the line may be left with a potential of $5V_{gm}$ above earth potential. Theoretically, this phenomenon may proceed infinitely increasing the voltage by successive increment of 2 times V_{gm} .

While the above description relates to the worst possible conditions, it is obvious that if the gap breakdown strength does not increase rapidly enough, successive re-strikes can build up a dangerous voltage in the open circuit line. However, due to leakage and corona loss, the maximum voltage on the line in such cases is limited to $5 V_{gm}$.

RESISTANCE SWITCHING:

It has been discussed above that current chopping, capacitive current breaking etc. give rise to severe voltage oscillations. These excessive voltage surges during circuit interruption can be prevented by the use of shunt resistance R connected across the circuit breaker contacts as shown in the equivalent circuit in Fig. 19.22. This is known as resistance switching.

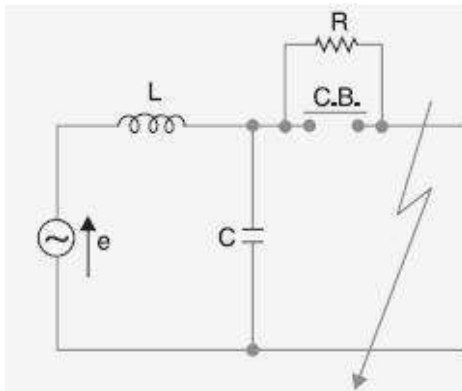

Fig. 19.22

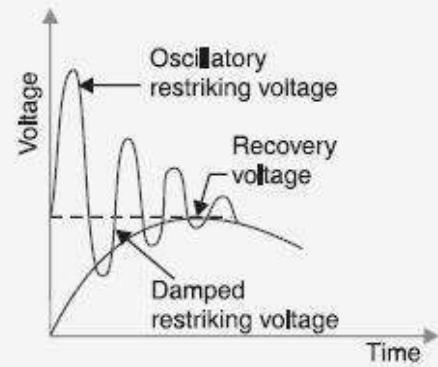

Fig. 19.23

Referring to Fig. 19.22, when a fault occurs, the contacts of the circuit breaker are opened and an arc is struck between the contacts. Since the contacts are shunted by resistance R , a part of arc current flows through this resistance. This results in the decrease of arc current and an increase in the rate of de-ionization of the arc path. Consequently, the arc resistance is increased. The increased arc resistance leads to a further increase in current through shunt resistance. This process continues until the arc current becomes so small that it fails to maintain the arc. Now, the arc is extinguished and circuit current is interrupted.

NRCM

YOUR ROOTS TO SUCCESS

The voltage equation is given by

$$L \frac{di}{dt} + \frac{1}{C} \int i_c dt = E \quad \text{and} \quad i = i_c + i_R$$

Therefore, the above equation become

$$L \frac{d(i_c + i_R)}{dt} + v_c = E$$

or

$$L \frac{di_c}{dt} + L \frac{di_R}{dt} + v_c = E$$

$$i_c = \frac{dq}{dt} = \frac{d(Cv_c)}{dt}$$

Therefore,

$$\frac{di_c}{dt} = \frac{d^2(Cv_c)}{dt^2} = C \frac{d^2v_c}{dt^2}$$

$$\frac{di_R}{dt} = \frac{d(v_c/R)}{dt} = \frac{1}{R} \frac{dv_c}{dt}$$

Substituting these values in the main equation, we get

$$LC \frac{d^2v_c}{dt^2} + \frac{L}{R} \frac{dv_c}{dt} + v_c = E$$

Taking Laplace Transform, we get

$$LCS^2v_c(S) + \frac{L}{R} S v_c(S) + v_c(S) = \frac{E}{S}$$

Other terms are zero, as $v_c = 0$ at $t = 0$

or $LCv_c(S) \left[S^2 + \frac{1}{RC} S + \frac{1}{LC} \right] = \frac{E}{S}$

or $v_c(S) = \frac{E}{SLC \left[S^2 + \frac{1}{RC} S + \frac{1}{LC} \right]}$

For no transient oscillation, all the roots of the equation should be real. One root is zero, i.e. $S = 0$ which is real. For the other two roots to be real, the roots of the quadratic equation in the denominator should be real. For this, the following condition should be satisfied.

$$\left[\left(\frac{1}{2RC} \right)^2 - \frac{1}{LC} \right] \geq 0 \quad \text{or} \quad \frac{1}{4R^2C^2} \geq \frac{1}{LC}$$

or $\frac{4}{LC} \leq \frac{1}{R^2C^2} \quad \text{or} \quad R^2 \leq \frac{LC}{4C^2}$

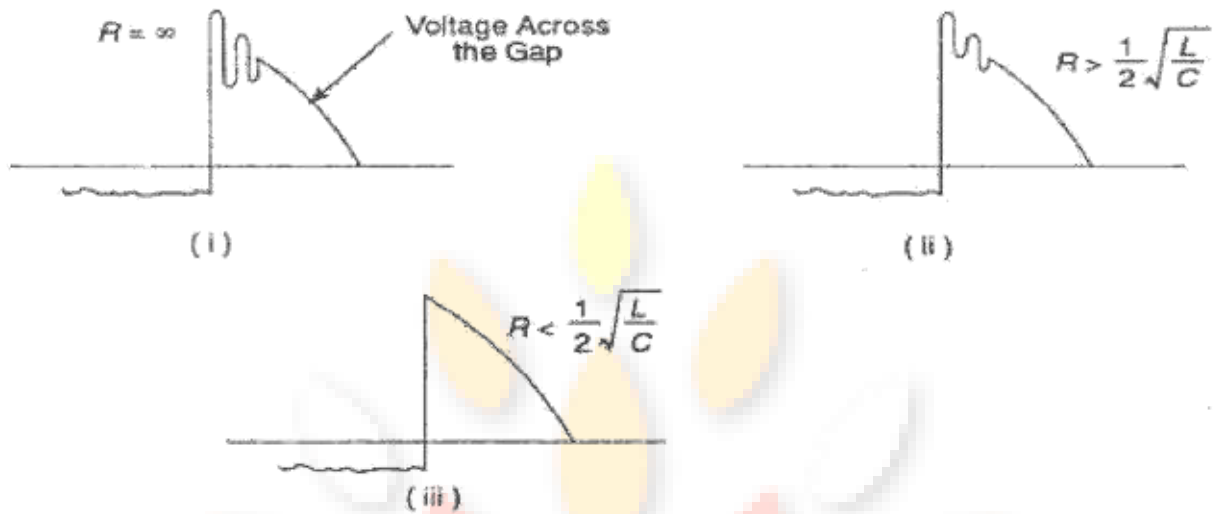

FIGURE 9.9 Transient oscillations for different values of R

or
$$R^2 \leq \frac{1}{4} \cdot \frac{L}{C} \quad \text{or} \quad R \leq \frac{1}{2} \sqrt{\frac{L}{C}}$$

Therefore, if the value of the resistance connected across the contacts of the circuit breaker is equal to or less than $\frac{1}{2}\sqrt{L/C}$ there will be no transient oscillation. If $R > \frac{1}{2}\sqrt{L/C}$, there will be oscillation. $R = \frac{1}{2}\sqrt{L/C}$ is known as critical resistance. Figure 9.9 shows the transient conditions for three different values of R .

The shunt resistor also helps in limiting the oscillatory growth of re-striking voltage. It can be proved mathematically that natural frequency of oscillations (or) the frequency of

$$f_n = \frac{1}{2\pi} \sqrt{\frac{1}{LC} - \frac{1}{4R^2C^2}}$$

damped oscillation of the circuit shown in Fig. 19.22 is given by:

The effect of shunt resistance R is to prevent the oscillatory growth of re-striking voltage and cause it to grow exponentially up to recovery voltage. This is being most effective when the value of R is so chosen that the circuit is critically damped. The value of R required for critical damping is 0.5 . Fig. 19.23 shows the oscillatory growth and exponential growth when the circuit is critically damped.

To sum up, resistors across breaker contacts may be used to perform one or more of the following functions:

- ❖ To reduce the rate of rise of re-striking voltage and the peak value of re-striking voltage.
- ❖ To reduce the voltage surges due to current chopping and capacitive current breaking.
- ❖ To ensure even sharing of re-striking voltage transient across the various breaks in multi break circuit breakers.
- ❖ It may be noted that value of resistance required to perform each function is usually different. However, it is often necessary to compromise and make one resistor do more than one of these functions.

Switchgear Components:

The following are some important components common to most of the circuit breakers:

1. Bushings
2. Circuit breaker contacts
3. Instrument transformers
4. Bus-bars and conductors

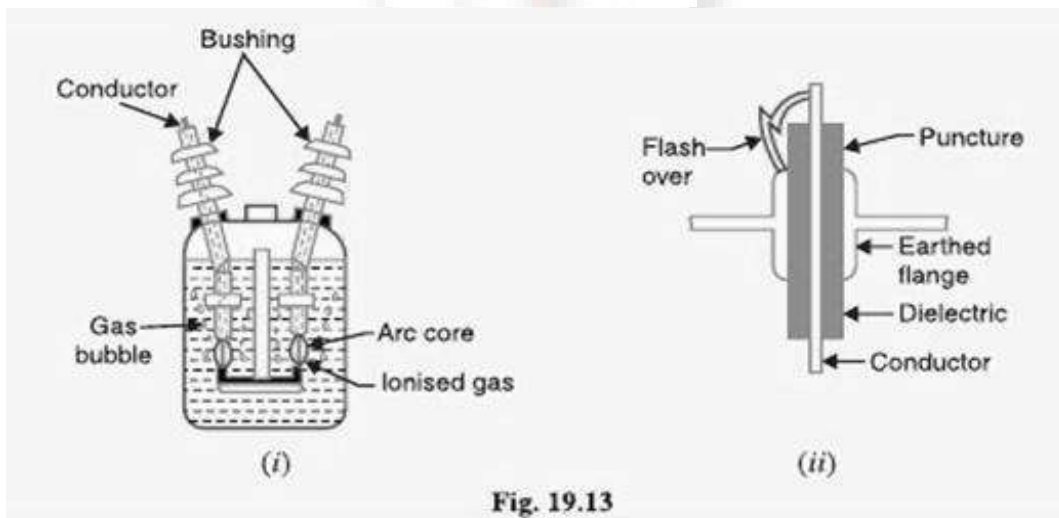

Bushings:

When a high voltage conductor passes through a metal sheet or frame which is at earth potential, the necessary insulation is provided in the form of bushing. The primary function of the bushing is to prevent electrical breakdown between the enclosed conductor and the surrounding earthed metal work. Fig. 19.13 (i) shows the use of bushing for a plain-break oil circuit breaker. The high voltage conductor passes through the bushing made of some insulating material (e.g., porcelain, steatite). Although there

are several types of bushing (e.g., condenser type, oil filled etc.), they perform the same function of insulating the conductor from earthed tank. The failure of the bushing can occur in two ways. Firstly, the breakdown may be caused by puncture i.e., dielectric failure of the insulating material of the bushing. Secondly, the breakdown may occur in the form of a flash-over between the exposed conductor at either end of the bushing and the earthed metal. Fig. 19.13 (ii) illustrates these two possibilities. The bushings are so designed that flash-over takes place before they get punctured. It is because the puncture generally renders the bushing insulation unserviceable and incapable of withstanding the normal voltage. On the other hand, a flash-over may result in comparatively harmless burning of the surface of the bushing which can then continue to give adequate service pending replacement.

Circuit breaker contacts:

The circuit breaker contacts are required to carry normal as well as short-circuit current. In carrying the normal current, it is desirable that the temperature should not rise above the specified limits and that there should be low voltage drop at the point of contact. In carrying breaking and making short-circuit currents, the chief effects to be dealt with are melting and Vaporization by the heat of the arc and those due to electromagnetic forces. Therefore, the design of contacts is of considerable importance for satisfactory operation of the circuit breakers. There are three types of circuit breaker contacts viz.

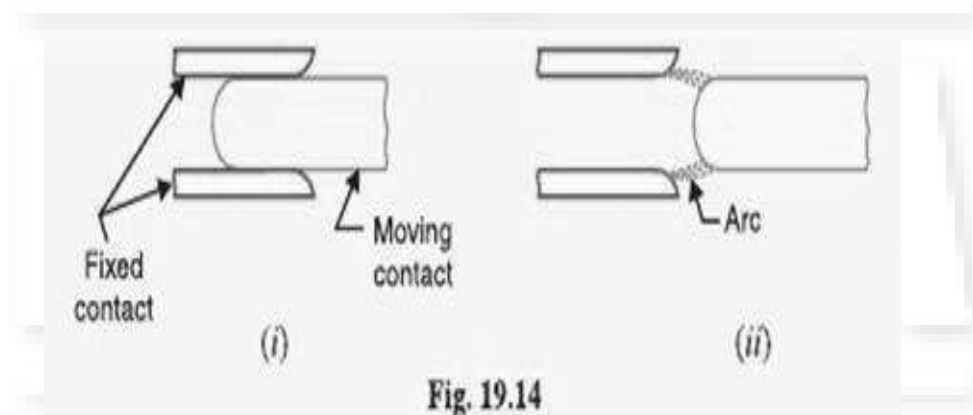
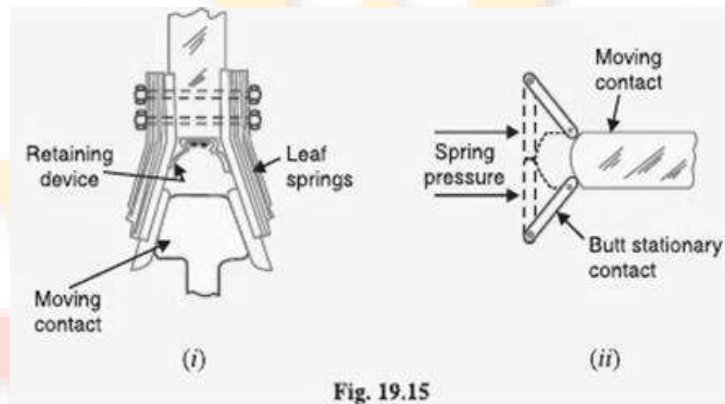

Fig. 19.14

- (a) **Tulip type contacts:** Fig. 19.14 (i) shows the Tulip type contact. It consists of moving contact which moves inside the fixed contacts. At contact separation, the arc is generally established between the tips of the fixed contacts and the tip of the moving contact as shown in Fig. 19.14 (ii). The advantage of this type of contact is that arcing is confined to the regions which are not in contact in the fully engaged position.



- (b) **Finger and wedge contacts:** Fig. 19.15 (i) shows the finger and wedge type contact. This type of contact is

largely used for low-voltage oil circuit breakers owing to the general unsuitability for use with arc control devices.

- (c) **Butt contacts:** Fig. 19.15 (ii) shows the butt type contact and is formed by the springs and the moving contact. It possesses two advantages. Firstly, spring pressure is available to assist contact separation. This is useful in single-break oil circuit breakers and air-blast circuit breakers where relatively small —loopl forces are available to assist in opening. Secondly, there is no grip force so that this type of contact is especially suitable for higher short circuit rating.

Instrument transformers:

In a modern power system, the circuits operate at very high voltages and carry current of thousands of amperes. The measuring instruments and protective devices cannot work satisfactorily if mounted directly on the power lines. This difficulty is overcome by installing instrument transformers on the power lines. The function of these instrument transformers is to transform voltages or currents in the power lines to values which are convenient for the operation of measuring instruments and relays.

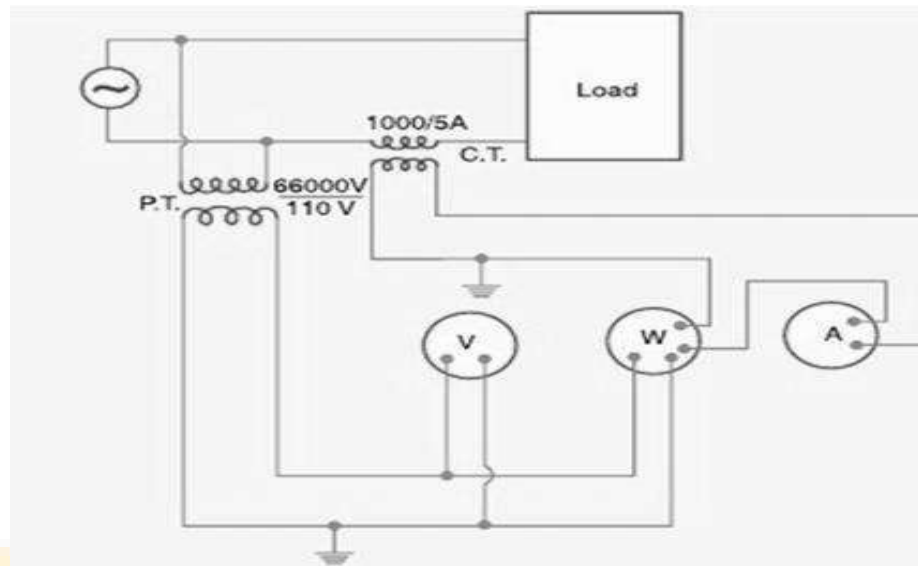

Fig. 19.16

There are two types of instrument transformers viz.

1. Current transformer (C.T.)
2. Potential transformer (P.T.)

The primary of current transformer is connected in the power line. The secondary winding provides for

the instruments and relays a current which is a constant fraction of the current in the line similarly, a potential transformer is connected with its primary in the power line. The secondary provides for the instruments and relays a voltage which is a known fraction of the line voltage. Fig. 19.16 shows the use of instrument transformers. The *potential transformer rated 66,000/110V provides a voltage supply for the potential coils of voltmeter and wattmeter. The current transformer rated 1000/5 A supplies current to the current coils of wattmeter and ammeter.

The use of instrument transformers permits the following advantages:

- (a) They isolate the measuring instruments and relays from high-voltage power circuits.
- (b) The leads in the secondary circuits carry relatively small voltages and currents. This permits to use wires of smaller size with minimum insulation.

Bus-bars and conductors: The current carrying members in a circuit breaker consist of fixed and moving contacts and the conductors connecting these to the points external to the breaker. If the switchgear is of outdoor type, these connections are connected directly to the overhead lines. In case of indoor switchgear, the incoming conductors to the circuit breaker are connected to the bus bars.

Circuit Breaker Ratings:

A circuit breaker may be called upon to operate under all conditions. However, major duties are imposed on the circuit breaker when there is a fault on the system in which it is connected. Under fault conditions, a circuit breaker is required to perform the following three duties:

- (i) It must be capable of opening the faulty circuit and breaking the fault current.
- (ii) It must be capable of being closed on to a fault.
- (iii) It must be capable of carrying fault current for a short time while another circuit breaker (in series) is clearing the fault.

Corresponding to the above mentioned duties, the circuit breakers have three ratings viz.

1. Breaking capacity
2. Making capacity and
3. Short-time capacity.

Breaking capacity: It is current (r.m.s.) that a circuit breaker is capable of breaking at given recovery voltage and under specified conditions (e.g., power factor, rate of rise of restriking voltage).

The breaking capacity is always stated at the r.m.s. value of fault Current at the instant of contact separation. When a fault occurs, there is considerable asymmetry in the fault current due to the Presence of a d.c. component. The d.c. component dies away rapidly, a typical decrement factor being 0.8 per cycle. Referring to

Fig. 19.24, the contacts are separated at DD'. At this instant, the fault current has

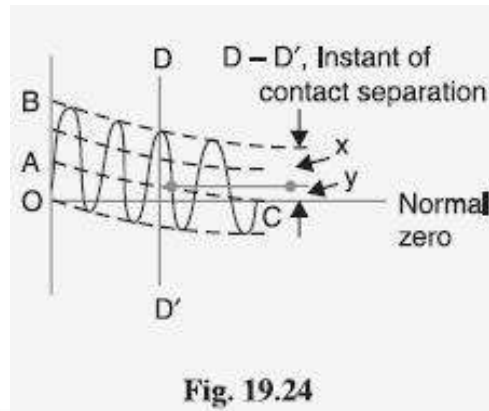

x = maximum value of a.c. component y = d.c. component

Symmetrical breaking current = r.m.s. value of a.c. component = $x/\sqrt{2}$

Asymmetrical breaking current = r.m.s. value of total current = $y/\sqrt{2}$

It is a common practice to express the breaking capacity in MVA by taking into account the rated breaking current and rated service voltage. Thus, if I is the rated breaking current in amperes and V is the rated service line voltage in volts, then for a 3-phase circuit,

$$\text{Breaking capacity} = 3 \times 10^{-6} MVA$$

In India (or Britain), it is a usual practice to take breaking current equal to the symmetrical breaking current. However, American practice is to take breaking current equal to asymmetrical breaking current. Thus the American rating given to a circuit breaker is higher than the Indian or British rating.

It seems to be illogical to give breaking capacity in MVA since it is obtained from the product of Short-circuit current and rated service voltage. When the short-circuit current is flowing, there is only a small voltage across the breaker contacts, while the service voltage appears across the contacts only after the current has been interrupted. Thus MVA rating is the product of two quantities which do not exist simultaneously in the circuit.

Therefore, the *agreed international standard of specifying breaking capacity is defined as the rated symmetrical breaking current at a rated voltage.

MAKING CAPACITY:

There is always a possibility of closing or making the circuit under short circuit conditions. The capacity of a breaker to —make current depends upon its ability to withstand and close successfully against the effects of electromagnetic forces. These forces are proportional to the square of maximum instantaneous current on closing. Therefore, making capacity is

stated in terms of a peak value of current instead of r.m.s. value.

The peak value of current (including d.c. component) during the first cycle of current wave after the closure of circuit breaker is known as making capacity.

It may be noted that the definition is concerned with the first cycle of current wave on closing the circuit breaker. This is because the maximum value of fault current possibly occurs in the first cycle only when maximum asymmetry occurs in any phase of the breaker. In other words, the making current is equal to the maximum value of asymmetrical current. To find this value, we must multiply symmetrical breaking current by $\sqrt{2}$ to convert this from r.m.s. to peak, and then by 1.8 to include the —doubling effect of maximum asymmetry. The total multiplication factor becomes $\sqrt{2} \times 1.8 = 2.55$.

Making capacity = $2.55 \times$ Symmetrical breaking capacity

SHORT-TIME RATING:

It is the period for which the circuit breaker is able to carry fault current while remaining closed. Sometimes a fault on the system is of very temporary nature and persists for 1 or 2 seconds after which the fault is automatically cleared. In the interest of continuity of supply, the breaker should not trip in such situations. This means that circuit breakers should be able to carry high current safely for some specified period while remaining closed i.e., they should have proven short-time rating. However, if the fault persists for duration longer than the specified time limit, the circuit breaker will trip, disconnecting the faulty section.

The short-time rating of a circuit breaker depends upon its ability to withstand The electromagnetic force effects and The temperature rise.

The oil circuit breakers have a specified limit of 3 seconds when the ratio of symmetrical breaking current to the rated normal current does not exceed 40. However, if this ratio is more than 40, then the specified limit is 1 second.

Normal current rating:

It is the r.m.s. value of current which the circuit breaker is capable of carrying continuously at its rated frequency under specified conditions. The only limitation in this case is the temperature rise of current-carrying parts.

CIRCUIT BREAKER

CLASSIFICATION OF CIRCUIT BREAKERS:

There are several ways of classifying the circuit breakers. However, the most general way of classification is on the basis of medium used for arc extinction. The medium used for arc extinction is usually oil, air, sulphur hexafluoride (SF₆) or vacuum. Accordingly, circuit breakers may be classified into:

1. **Oil circuit breakers:** which employ some insulating oil (e.g., transformer oil) for arc extinction?
2. **Air-blast circuit breakers:** in which high pressure air-blast is used for extinguishing the arc.
3. **Sulphur hexafluoride circuit breakers:** in which sulphur hexafluoride (SF₆) gas is used for arc extinction.
4. **Vacuum circuit breakers:** in which vacuum is used for arc extinction.

Each type of circuit breaker has its own advantages and disadvantages. In the following sections, we shall discuss the construction and working of these circuit breakers with special emphasis on the way the arc extinction is facilitated.

Oil Circuit Breakers:

In such circuit breakers, some insulating oil (e.g., transformer oil) is used as an arc quenching medium. The contacts are opened under oil and an arc is struck between them. The heat of the arc evaporates the surrounding oil and dissociates it into a substantial volume of gaseous hydrogen at high pressure. The hydrogen gas occupies a volume about one thousand times that of the oil decomposed. The oil is, therefore, pushed away from the arc and an expanding hydrogen gas bubble surrounds the arc region and adjacent portions of the contacts (See Fig. 19.2). The arc extinction is facilitated mainly by two processes. Firstly, the hydrogen gas has high heat conductivity and cools the arc, thus aiding the de-ionization of the medium between the contacts. Secondly, the gas sets up turbulence in the oil and forces it into the space between contacts, thus eliminating the arcing products from the arc path. The result is that arc is extinguished and circuit current is interrupted.

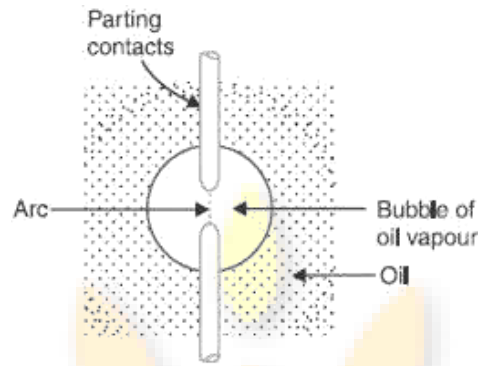

Fig. 19.2

The advantages of oil as an arc quenching medium are:

1. It absorbs the arc energy to decompose the oil into gases which have excellent cooling properties.
2. It acts as an insulator and permits smaller clearance between live conductors and earthed components.
3. The surrounding oil presents cooling surface in close proximity to the arc.

The disadvantages of oil as an arc quenching medium are:

1. It is inflammable and there is a risk of a fire.
2. It may form an explosive mixture with air
3. The arcing products (e.g., carbon) remain in the oil and its quality deteriorates with successive operations. This necessitates periodic checking and replacement of oil.

Types of Oil Circuit Breakers:

The oil circuit breakers find extensive use in the power system. These can be classified into the following types:

1. Bulk oil circuit breakers
2. Low oil circuit breakers

Bulk oil circuit breakers:

Which use a large quantity of oil. The oil has to serve two purposes. Firstly, it extinguishes the arc during opening of contacts and secondly, it insulates the current conducting parts from one another and from the earthed tank. Such circuit breakers may be classified into:

1. Plain break oil circuit breakers
2. Arc control oil circuit breakers.

In the former type, no special means is available for controlling the arc and the contacts are directly exposed to the whole of the oil in the tank. However, in the latter type, special arc control devices are employed to get the beneficial action of the arc as efficiently as possible.

Plain Break Oil Circuit Breakers:

A plain-break oil circuit breaker involves the simple process of separating the contacts under the whole of the oil in the tank. There is no special system for arc control other than the increase in length caused by the separation of contacts. The arc extinction occurs when a certain critical gap between the contacts is reached. The plain- break oil circuit breaker is the earliest type from which all other circuit breakers have developed. It has a very simple construction. It consists of fixed and moving contacts enclosed in a strong weather-tight earthed tank containing oil up to a certain level and an air cushion above the oil level. The air cushion provides sufficient room to allow for the reception of the arc gases without the

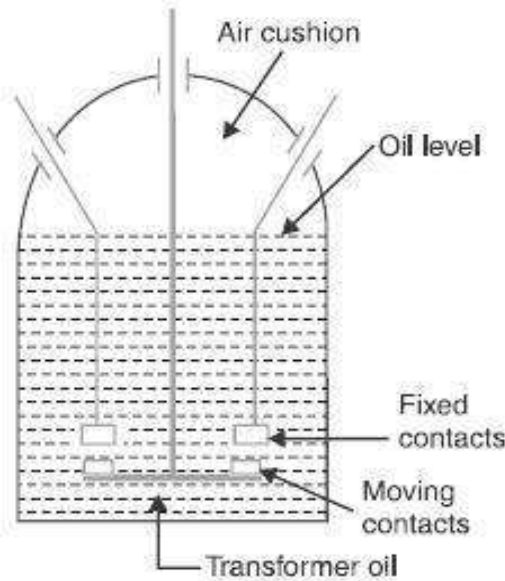

Fig. 19.3

generation of unsafe pressure in the dome of the circuit breaker. It also absorbs the mechanical shock of the upward oil movement. Fig. 19.3 shows a double break plain oil circuit breaker. It is called a double break because it provides two breaks in series.

Under normal operating conditions, the fixed and moving contacts remain closed and the breaker carries the normal circuit Current. When a fault occurs, the moving contacts are pulled down by the protective system and an arc is struck which vaporizes the oil mainly into hydrogen gas.

The arc extinction is facilitated by the following processes:

- ❖ The hydrogen gas bubble generated around the arc cools the arc column and aids the deionization of the medium between the contacts.
- ❖ The gas sets up turbulence in the oil and helps in eliminating the arcing products from the arc path.

- ❖ As the arc lengthens due to the separating contacts, the dielectric strength of the medium is increased.
- ❖ The result of these actions is that at some critical gap length, the arc is extinguished and the circuit current is interrupted.

Disadvantages:

There is no special control over the arc other than the increase in length by separating the moving contacts. Therefore, for successful Interruption, Long arc length is necessary.

- ❖ These breakers have long and inconsistent arcing times.
- ❖ These breakers do not permit high speed interruption.

Due to these disadvantages, plain-break oil circuit breakers are used only for low voltage applications where high breaking-capacities are not important. It is a usual practice to use such breakers for low capacity installations for Voltages not exceeding 11 kV.

ARC CONTROL OIL CIRCUIT BREAKERS:

In case of plain-break oil circuit breaker discussed above, there is very little artificial control over the arc. Therefore, comparatively long arc length is essential in order that turbulence in the oil caused by the gas may assist in quenching it. However, it is necessary and desirable that final arc extinction should occur while the contact gap is still short. For this purpose, some arc control is incorporated and the breakers are then called arc control circuit breakers.

There are two types of such breakers, namely:

1. **Self-blast oil circuit breakers**— in which arc control is provided by internal means i.e. the arc itself is employed for its own extinction efficiently.
2. **Forced-blast oil circuit breakers**— in which arc control is provided by mechanical means external to the circuit breaker.

Self-blast oil circuit breakers:

In this type of circuit breaker, the gases produced during arcing are confined to a small volume by the use of an insulating rigid pressure chamber or pot surrounding the contacts. Since the space available for the arc gases is restricted by the chamber, a very high pressure is developed to force the oil and gas through or around the arc to extinguish it. The magnitude of pressure developed depends upon the value of fault current to be interrupted. As the pressure is generated by the arc itself, therefore, such breakers are some times called self-generated pressure oil circuit breakers.

The pressure chamber is relatively cheap to make and gives reduced final arc extinction gap length and arcing time as against the plain-break oil circuit breaker. Several designs of pressure chambers (sometimes called explosion pots) have been developed and a few of them are described below:

Plain explosion pot:

It is a rigid cylinder of insulating material and encloses the fixed and moving contacts (See Fig. 19.4). The moving contact is a cylindrical rod passing through a restricted opening (called throat) at the bottom. When a fault occurs, the contacts get separated and an arc is struck between them. The heat of the arc decomposes oil into a gas at very high pressure in the pot. This high pressure forces the oil and gas through and round the arc to extinguish it. If the final arc extinction does not take place while the moving contact is still within the pot, it occurs immediately after the moving contact leaves the pot. It is because emergence of the moving contact from the pot is followed by a violent rush of gas and oil through the throat producing rapid extinction.

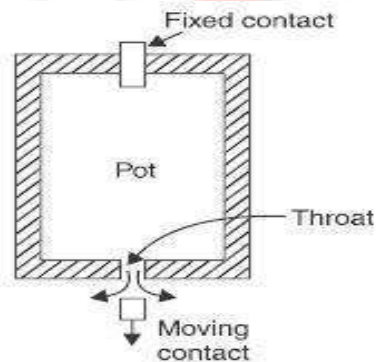

Fig. 19.4

The principal limitation of this type of pot is that it cannot be used for very low or for very high fault currents. With low fault currents, the pressure developed is small, thereby increasing the arcing time. On the other hand, with high fault currents, the gas is produced so rapidly that explosion pot is liable to burst due to high pressure. For this reason, plain explosion pot operates well on moderate short-circuit currents only where the rate of gas evolution is moderate

Cross jet explosion pot:

This type of pot is just a modification of plain explosion pot and is illustrated in Fig. 19.5. It is made of insulating material and has channels on one side which act as arc splitters. The arc splitters help in increasing the arc length, thus facilitating arc extinction. When a fault

occurs, the moving contact of the circuit breaker begins to separate. As the moving contact is withdrawn, the arc is initially struck in the top of the pot. The gas generated by the arc exerts pressure on the oil in the back passage. When the moving contact uncovers the arc splitter ducts, fresh oil is forced *across the arc path. The arc is, therefore, driven sideways into the —arc splitters‡ which increase the arc length, causing arc extinction.

The cross-jet explosion pot is quite efficient for interrupting heavy fault currents. However, for low fault currents, the gas pressure is †small and consequently the pot does not give a

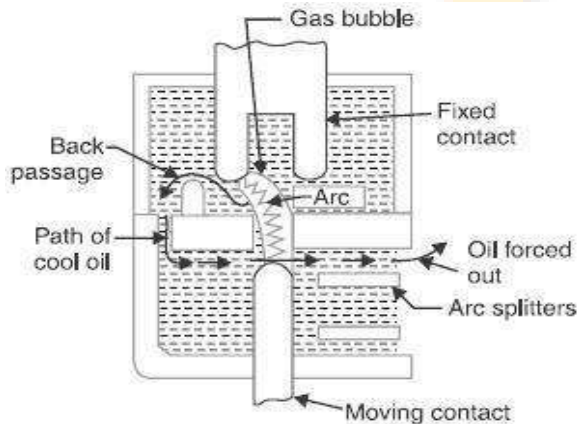

Fig. 19.5

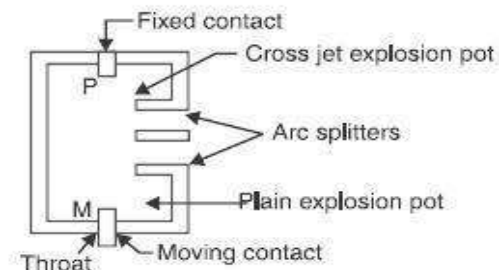

Fig. 19.6

satisfactory operation.

Self-compensated explosion pot:

This type of pot is essentially a combination of plain explosion pot and cross jet explosion pot. Therefore, it can interrupt low as well as heavy short circuit currents with reasonable accuracy. Fig. 19.6 shows the schematic diagram of self-compensated explosion pot. It consists of two chambers; the upper chamber is the cross-jet explosion pot with two arc splitter ducts while the lower one is the plain explosion pot. When the short-circuit current is heavy, the rate of generation of gas is very high and the device behaves as a cross-jet explosion pot. The arc extinction takes place when the moving contact uncovers the first or second arc splitter duct. However, on low short-circuit currents, the rate of gas generation is small and the tip of the moving contact has the time to reach the lower chamber. During this time, the gas builds up sufficient pressure as there is very little leakage through arc splitter ducts due to the obstruction offered by the arc path and right angle bends. When the moving contact comes out of the throat, the arc is extinguished by plain pot action.

It may be noted that as the severity of the short circuit current increases, the device operates less and less as a plain explosion pot and more and more as a cross-jet explosion pot. Thus the tendency is to make the control self-compensating over the full range of fault currents to be interrupted.

Forced-blast oil circuit breakers:

In the self-blast oil circuit breakers discussed above, the arc itself generates the necessary pressure to force the oil across the arc path. The major limitation of such breakers is that arcing times tend to be long and inconsistent when operating against currents considerably less than the rated currents. It is because the gas generated is much reduced at low values of fault currents. This difficulty is overcome in forced-blast oil circuit breakers in which the necessary pressure is generated by external mechanical means independent of the fault currents to be broken.

In a forced -blast oil circuit breaker, oil pressure is created by the piston-cylinder arrangement. The movement of the piston is mechanically coupled to the moving contact. When a fault occurs, the contacts get separated by the protective system and an arc is struck between the contacts. The piston forces a jet of oil towards the contact gap to extinguish the arc. It may be noted that necessary oil pressure produced does not in any way depend upon the fault current to be broken.

Advantages:

- ❖ Since oil pressure developed is independent of the fault current to be interrupted, the performance at low currents is more consistent than with self-blast oil circuit breakers.
- ❖ The quantity of oil required is reduced considerably.

Low Oil Circuit Breakers:

In the bulk oil circuit breakers discussed so far, the oil has to perform two functions. Firstly, it acts as an arc quenching medium and secondly, it insulates the live parts from earth. It has been found that only a small percentage of oil is actually used for arc extinction while the major part is utilized for insulation purposes. For this reason, the quantity of oil in bulk oil circuit breakers reaches a very high figure as the system voltage increases. This not only increases the expenses, tank size and weight of the breaker but it also increase the fire risk and maintenance problems.

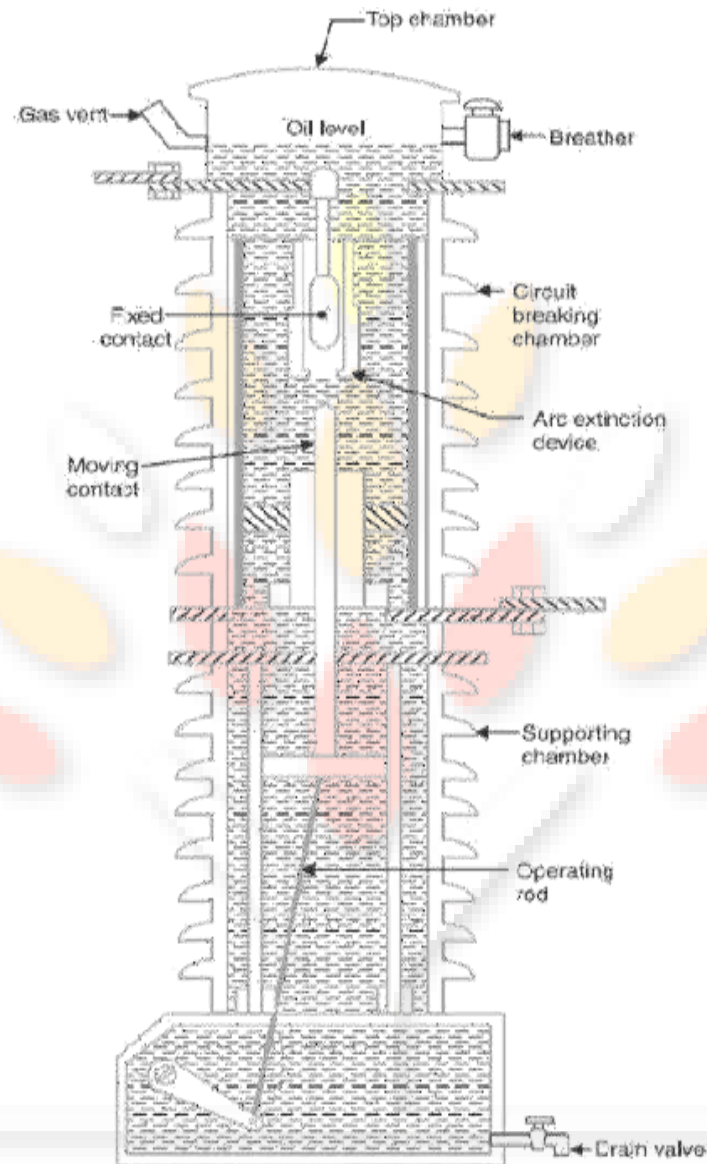

Fig. 19.7 Low-oil Circuit Breaker

The fact that only a small percentage of oil (about 10% of total) in the bulk oil circuit breaker is actually used for arc extinction leads to the question as to why the remainder of the oil, that is not immediately surrounding the device, should not be omitted with consequent saving in bulk, weight and fire risk. This led to the development of low-oil circuit breaker. A low oil circuit breaker employs solid materials for insulation purposes and uses a small quantity of oil which is just sufficient for arc extinction. As regards quenching the arc, the oil behaves identically in bulk as well as low oil circuit breaker. By using

suitable arc control devices, the arc extinction can be further facilitated in a low oil circuit breaker.

Construction:

Fig 19.7 shows the cross section of a single phase low oil circuit breaker. There are two compartments separated from each other but both filled with oil. The upper chamber is the circuit breaking chamber while the lower one is the supporting chamber. The two chambers are separated by a partition and oil from one chamber is prevented from mixing with the other chamber. This arrangement permits two advantages. Firstly, the circuit breaking chamber requires a small volume of oil which is just enough for arc extinction. Secondly, the amount of oil to be replaced is reduced as the oil in the supporting chamber does not get contaminated by the arc.

Supporting chamber:

It is a porcelain chamber mounted on a metal chamber. It is filled with oil which is physically separated from the oil in the circuit breaking compartment. The oil inside the supporting chamber and the annular space formed between the porcelain insulation and bakelised paper is employed for insulation purposes only.

Circuit-breaking chamber:

It is a porcelain enclosure mounted on the top of the supporting compartment. It is filled with oil and has the following parts:

1. upper and lower fixed contacts
2. Moving contact
3. Turbulator

The moving contact is hollow and includes a cylinder which moves down over a fixed piston. The turbulator is an arc control device and has both axial and radial vents. The axial venting ensures the interruption of low currents whereas radial venting helps in the interruption of heavy currents.

Top chamber:

It is a metal chamber and is mounted on the circuit-breaking chamber. It provides expansion space for the oil in the circuit breaking compartment. The top chamber is also provided with a separator which prevents any loss of oil by centrifugal action caused by circuit breaker operation during fault conditions.

Operation:

Under normal operating conditions, the moving contact remains engaged with the upper fixed contact. When a fault occurs, the moving contact is pulled down by the tripping springs and an arc is struck. The arc energy vaporizes the oil and produces gases under high pressure. This action constrains the oil to pass through a central hole in the moving contact and results in forcing series of oil through the respective passages of the tabulator. The process of tabulation is orderly one, in which the sections of the arc are successively quenched by the effect of separate streams of oil moving across each section in turn and bearing away its gases.

A low oil circuit breaker has the following advantages over a bulk oil circuit breaker:

1. It requires lesser quantity of oil.
2. It requires smaller space.
3. There is reduced risk of fire.
4. Maintenance problems are reduced.

A low oil circuit breaker has the following disadvantages as compared to a bulk oil circuit breaker:

1. Due to smaller quantity of oil, the degree of carbonization is increased.
2. There is a difficulty of removing the gases from the contact space in time.
3. The dielectric strength of the oil deteriorates rapidly due to high degree of carbonization.

Maintenance of Oil Circuit Breakers:

The maintenance of oil circuit breaker is generally concerned with the checking of contacts and dielectric strength of oil. After a circuit breaker has interrupted fault currents a few times or load currents several times, its contacts may get burnt by arcing and the oil may lose some of its dielectric strength due to carbonization. This results in the reduced rupturing capacity of the breaker. There fore, it is a good practice to inspect the circuit breaker at regular intervals of 3 or 6 months.

During inspection of the breaker, the following points should be kept in view:

- ❖ Check the current carrying parts and arcing contacts. If the burning is severe, the contacts should be replaced.
- ❖ Check the dielectric strength of the oil. If the oil is badly discolored, it should be changed or reconditioned. The oil in good condition should withstand 30 kV for one minute in a standard oil testing cup with 4 mm gap between electrodes.

- ❖ Check the insulation for possible damage. Clean the surface and remove carbon deposits with a strong and dry fabric.
- ❖ Check the oil level.
- ❖ Check closing and tripping mechanism.

Air-Blast Circuit Breakers:

These breakers employ a high pressure *air-blast as an arc quenching medium. The contacts are opened in a flow of air-blast established by the opening of blast valve. The air-blast cools the arc and sweeps away the arcing products to the atmosphere. This rapidly increases the dielectric strength of the medium between contacts and prevents from re-establishing the arc. Consequently, the arc is extinguished and flow of current is interrupted.

An air-blast circuit breaker has the following advantages over an oil circuit breaker:

1. The risk of fire is eliminated.
2. The arcing products are completely removed by the blast whereas the oil deteriorates with successive operations; the expense of regular oil replacement is avoided.
3. The growth of dielectric strength is so rapid that final contact gap needed for arc extinction is very small. This reduces the size of the device.
4. The arcing time is very small due to the rapid buildup of dielectric strength between contacts. Therefore, the arc energy is only a fraction of that in oil circuit breakers, thus resulting in less burning of contacts.
5. Due to lesser arc energy, air-blast circuit breakers are very suitable for conditions where frequent operation is required.
6. The energy supplied for arc extinction is obtained from high pressure air and is independent of the current to be interrupted.

The use of air as the arc quenching medium offers the following disadvantages:

1. The air has relatively inferior arc extinguishing properties.
2. The air-blast circuit breakers are very sensitive to the variations in the rate of rise of re striking voltage.
3. Considerable maintenance is required for the compressor plant which supplies the air-blast.
4. The air blast circuit breakers are finding wide applications in high voltage installations.
5. Majority of the circuit breakers for voltages beyond 110 kV are of this type.

Types of Air-Blast Circuit Breakers:

Depending upon the direction of air-blast in relation to the arc, air-blast circuit breakers are classified into:

1. **Axial-blast type** in which the air-blast is directed along the arc path as shown in Fig. 19.8(i).
2. **Cross-blast type** in which the air-blast is directed at right angles to the arc path as shown in Fig. 19.8 (ii).
3. **Radial-blast type** in which the air-blast is directed radially as shown in Fig. 19.8 (iii).

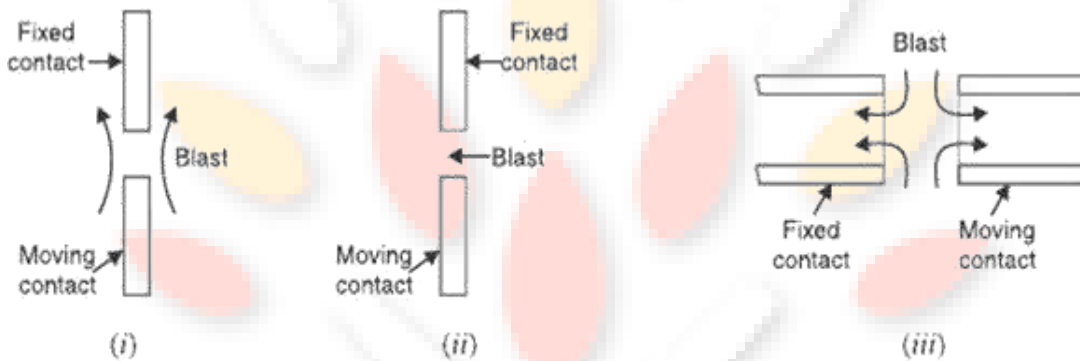

Fig. 19.8

Axial-blast air circuit breaker:

Fig 19.9 shows the essential components of a typical axial blast air circuit breaker. The fixed and moving contacts are held in the closed position by spring pressure under normal conditions. The air reservoir is connected to the arcing chamber through an air valve. This valve remains closed under normal conditions but opens automatically by the tripping impulse when a fault occurs on the system.

When a fault occurs, the tripping impulse causes opening of the air valve which connects the

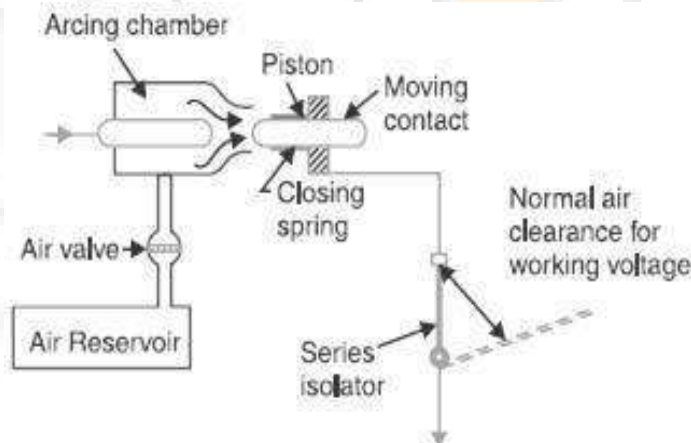

Fig. 19.9

circuit breaker reservoir to the arcing chamber. The high pressure air entering the arcing chamber pushes away the moving contact against spring pressure. The moving contact is separated and an arc is struck. At the same time, high pressure air blast flows along the arc and takes away the ionized gases along with it. Consequently, the arc is extinguished and current flow is interrupted.

It may be noted that in such circuit breakers, the contact separation required for interruption is generally small (1.75 cm or so). Such a small gap may constitute inadequate clearance for the normal service voltage. Therefore, an isolating switch is incorporated as a part of this type of circuit breaker. This switch opens immediately after fault interruption to provide the necessary clearance for insulation.

Cross-blast air breaker:

In this type of circuit breaker, an air-blast is directed at right angles to the arc. The cross-blast lengthens and forces the arc into a suitable chute for arc extinction. Fig. 19.10 shows the essential parts of a typical cross-blast Air circuit breaker. When the moving contact is withdrawn, an arc is struck between the fixed and moving contacts. The high pressure cross-blast forces the arc into a chute consisting of arc splitters and baffles. The splitters serve to increase the length of the arc and baffles give improved cooling. The result is that arc is extinguished and flow of current is interrupted. Since blast pressure is same for all currents, the inefficiency at low currents is eliminated. The final gap for interruption is great enough to give normal insulation clearance so that a series isolating switch is not necessary.

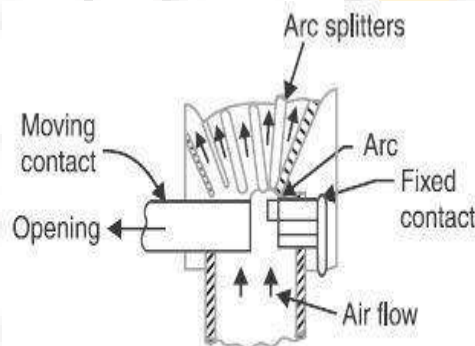

Fig. 19.10

SULPHUR HEXAFLUORIDE (SF₆) CIRCUIT BREAKERS:

In such circuit breakers, sulphur hexafluoride (SF₆) gas is used as the arc quenching medium. The SF₆ is an electro-negative gas and has a strong tendency to absorb free electrons. The contacts of the breaker are opened in a high pressure flow of SF₆ gas and an arc is struck between them. The conducting free electrons in the arc are rapidly captured by the gas to form relatively immobile negative ions. This loss of conducting electrons in the arc quickly builds up enough insulation strength to extinguish the arc. The SF₆ circuit breakers have been found to be very effective for high power and high voltage service.

Construction:

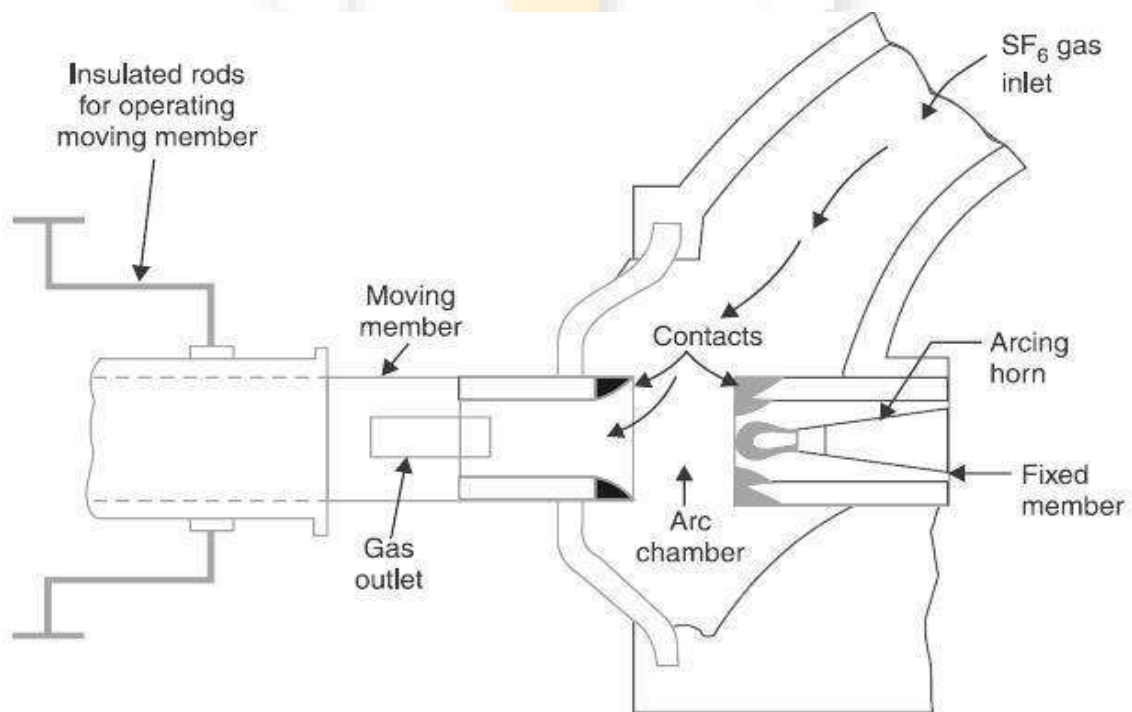

Fig. 19.11

Fig. 19.11 shows the parts of a typical SF₆ circuit breaker. It consists of fixed and moving contacts enclosed in a chamber (called arc interruption chamber) containing SF₆ gas. This chamber is connected to SF₆ gas reservoir. When the contacts of breaker are opened, the valve mechanism permits a high pressure SF₆ gas from the reservoir to flow towards the arc interruption chamber. The fixed contact is a hollow cylindrical current carrying contact fitted with an arc horn. The moving contact is also a hollow cylinder with rectangular holes in the sides to permit the SF₆ gas to let out through these holes after flowing along and across the arc. The tips of fixed contact, moving contact and arcing horn are coated with

copper-tungsten arc resistant material. Since SF₆ gas is Costly, it is reconditioned and reclaimed by suitable auxiliary system after each operation of the breaker.

Working:

In the closed position of the breaker, the contacts remain surrounded by SF₆ gas at a pressure of about 2.8 kg/cm. When the breaker operates, the moving contact is pulled apart and an arc is struck between the contacts. The movement of the moving contact is synchronized with the opening of a valve which permits SF₆ gas at 14 kg/cm pressure from the reservoir to the arc interruption chamber. The high pressure flow of SF₆ rapidly absorbs the free electrons in the arc path to form immobile negative ions which are ineffective as charge carriers. The result is that the medium between the contacts quickly builds up high dielectric strength and causes the extinction of the arc. After the breaker operation (i.e., after arc extinction), the valve is closed by the action of a set of springs.

Advantages:

Due to the superior arc quenching properties of SF₆ gas, the SF₆ circuit breakers have many advantages over oil or air circuit breakers. Some of them are listed below:

1. Due to the superior arc quenching property of SF₆, such circuit breakers have very short arcing time.
2. Since the dielectric strength of SF₆ gas is 2 to 3 times that of air, such breakers can interrupt much larger currents.
3. The SF₆ circuit breaker gives noiseless operation due to its closed gas circuit and no exhaust to atmosphere unlike the air blast circuit breaker
4. The closed gas enclosure keeps the interior dry so that there is no moisture problem.
5. There is no risk of fire in such breakers because SF₆ gas is non-inflammable.
6. There are no carbon deposits so that tracking and insulation problems are eliminated.
7. The SF₆ breakers have low maintenance cost, light foundation requirements and minimum auxiliary equipment.
8. Since SF₆ breakers are totally enclosed and sealed from atmosphere, they are particularly suitable where explosion hazard exists e.g., coal mines.

Disadvantages:

1. SF₆ breakers are costly due to the high cost of SF₆.
2. Since SF₆ gas has to be reconditioned after every operation of the breaker, additional equipment is required for this purpose.

Applications:

A typical SF6 circuit breaker consists of interrupter units each capable of dealing with currents up to 60 kA and voltages in the range of 50—80 kV. A number of units are connected in series according to the system voltage. SF6 circuit breakers have been developed for voltages 115 kV to 230 kV, power ratings 10 MVA to 20 MVA and interrupting time less than 3 cycles.

VACUUM CIRCUIT BREAKERS (VCB):

In such breakers, vacuum (degree of vacuum being in the range from 10^{-4} to 10^{-6} torr) is used as the arc quenching medium. Since vacuum offers the highest insulating strength, it has far superior arc quenching properties than any other medium. For example, when contacts of a breaker are opened in vacuum, the interruption occurs at first current zero with dielectric strength between the contacts building up at a rate thousands of times higher than that obtained with other circuit breakers.

Principle:

The production of arc in a vacuum circuit breaker and its extinction can be explained as follows:

When the contacts of the breaker are opened in vacuum (10^{-4} to 10^{-6} torr), an arc is produced between the contacts by the ionization of metal vapours of contacts. However, the arc is quickly extinguished because the metallic vapours, electrons and ions produced during arc rapidly condense on the surfaces of the circuit breaker contacts, resulting in quick recovery of dielectric strength. The reader may note the salient feature of vacuum as an arc quenching medium. As soon as the arc is produced in vacuum, it is quickly extinguished due to the fast rate of recovery of dielectric strength in vacuum.

Construction:

Fig. 19.12 shows the parts of a typical vacuum circuit breaker. It consists of fixed contact, moving contact and arc shield mounted inside a vacuum chamber. The movable member is connected to the control mechanism by stainless steel bellows. This enables the permanent sealing of the vacuum chamber so as to eliminate the possibility of leak. A glass vessel or ceramic vessel is used as the outer insulating body. The arc shield prevents the deterioration of the internal dielectric strength by preventing metallic vapours falling on the inside surface of the outer insulating cover.

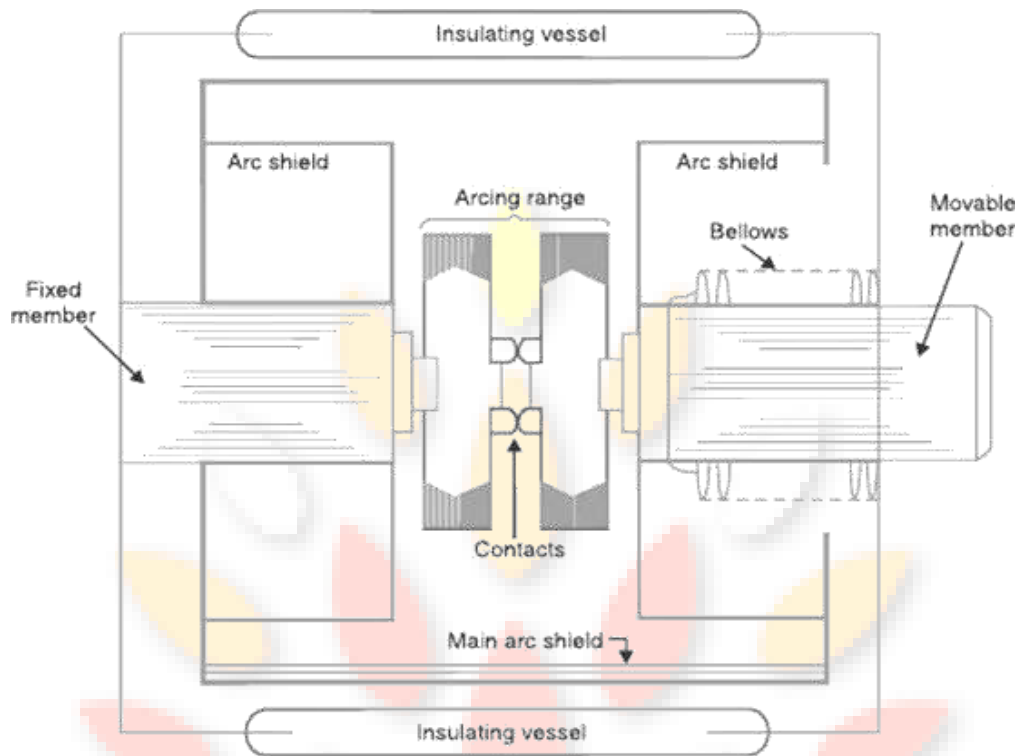

Fig. 19.12

Working:

When the breaker operates, the moving contact separates from the fixed contact and an arc is struck between the contacts. The production of arc is due to the ionization of metal ions and depends very much upon the material of contacts. The arc is quickly extinguished because the metallic vapours, electrons and ions produced during arc are diffused in a short time and seized by the surfaces of moving and fixed members and shields. Since vacuum has very fast rate of recovery of dielectric strength, the arc extinction in a vacuum breaker occurs with a short contact separation (say 0.625 cm).

Vacuum circuit breakers have the following advantages:

1. They are compact, reliable and have longer life.
2. There is no generation of gas during and after operation.
3. They can interrupt any fault current. The outstanding feature of a V C B is that it can break any heavy fault current perfectly just before the contacts reach the definite open position.
4. They require little maintenance and are quiet in operation.
5. They have low arc energy.
6. They have low inertia and hence require smaller power for control mechanism.

Applications:

For a country like India, where distances are quite large and accessibility to remote areas difficult, the installation of such outdoor, maintenance free circuit breakers should prove a definite advantage. Vacuum circuit breakers are being employed for outdoor applications ranging from 22 kV to 66 kV. Even with limited rating of say 60 to 100 MVA, they are suitable for a majority of applications in rural areas.



YOUR ROOTS TO SUCCESS...

UNIT - II

ELECTROMAGNETIC AND STATIC RELAYS

3.2 ELECTROMAGNETIC RELAY

The following are the important types of electromagnetic relays.

1. Attracted Armature type Relay
2. Balanced Beam Relay
3. Induction Disc Relay
4. Induction Cup Relay

The Electro magnetic Relay operator when operating torque/force is greater than the restraining torque/force.

Attracted Armature Relay

This is one of the simplest type of electromagnetic relay. Attracted armature relay has two types of constructions.

1. Hinged armature constructed
2. Plunger type construction.

Hinged armature type relay is shown in the figure 3.1(a) drawn below.

Figure:3.1

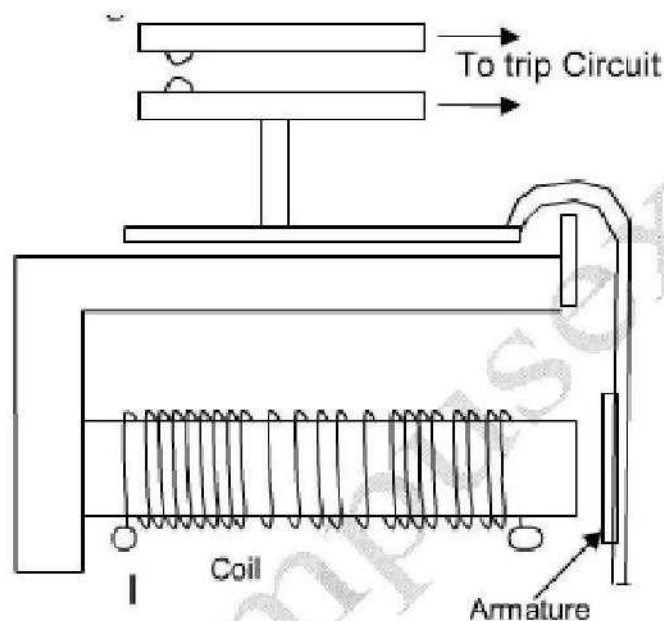

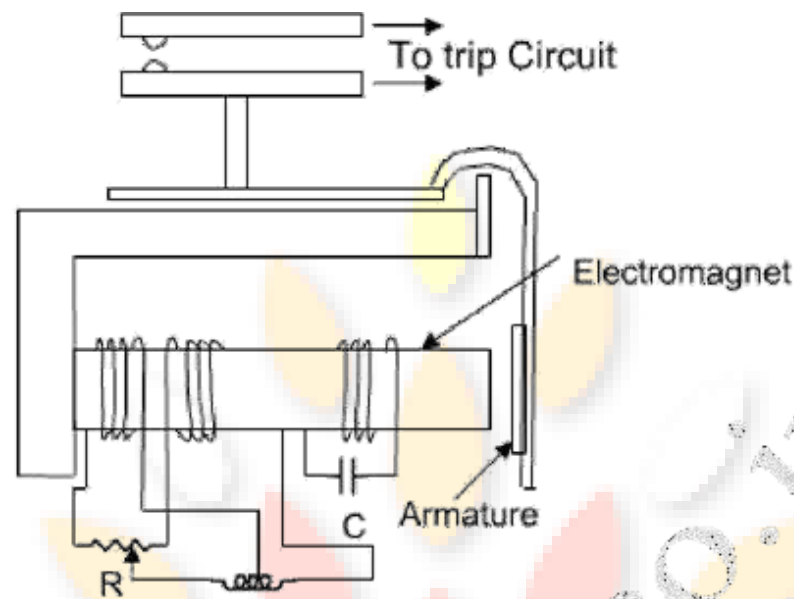

This type of relay consists of a coil and an electromagnet energized by that coil. The coil is energized by the operating quantity which may be proportional to the circuit current or voltage. This operating current produces a magnetic flux which in turn produces an electromagnetic force.

If the actuating quantity is dc then the electromagnetic force is constant. If the actuating quantity is ac, then the electromagnetic force is proportional to the square of flux or current. Since current is sinusoidal in ac $I = I_{max} \sin \omega t$

$$\text{Then } f = KI^2 = K(I_{max} \sin \omega t)^2 = \frac{1}{2}k(I_{max}^2 - I_{max}^2 \cos 2\omega t)$$

From the above equation, we can see that the net electromagnetic force consists of two components. The first component $\frac{1}{2}k(I_{max}^2)$ is constant and does not vary with time.

The second component $\frac{1}{2}k(I_{max}^2) \cos 2\omega t$ depends on time and it pulsates at double the frequency. Hence the total electromagnetic force is a double frequency pulsating force. This force may cause the armature to vibrate at double the frequency. Hence a humming noise is produced. This difficulty can be overcome by using two coils, one coil energized through a phase shifting network as shown in the figure 3.1(b) in which advantages of attracture armature type relay is

1. Its operating speed is very high
2. They can operate on both ac and dc.
3. Then dc transients can be reduced.

Balanced Beam Relay

Balanced Beam Relay consists of a horizontal relay pivoted at the centre. At the two ends of the beam, one armature is attached, and each armature is energized by two coils- operating coil and restraining coil.

When operating force is less than the restraining force, the beam remains in horizontal or slightly tilted position by means of spring such that the contacts are open. When operating force is greater than the restraining force the beam tilts down to close the contacts. The construction is shown in figure 3.2

Figure 3.2

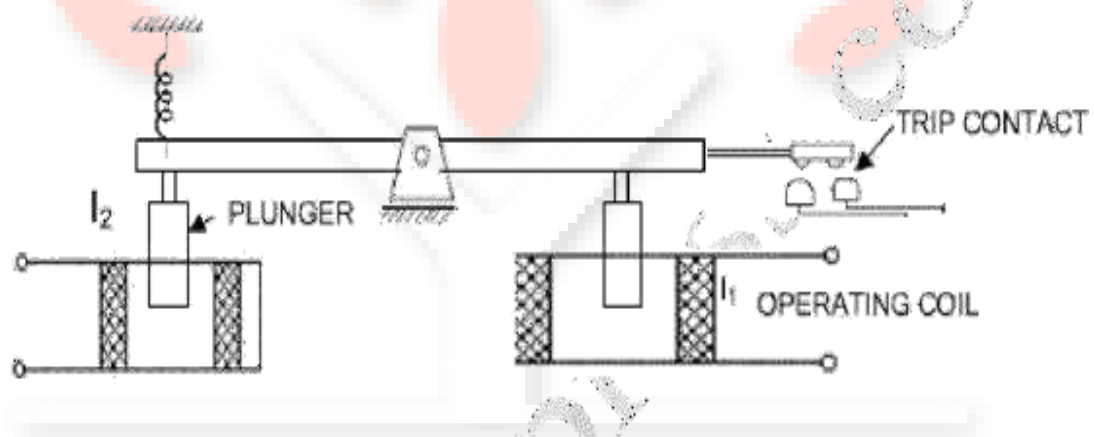

Operating Principle

The net electromagnetic torque is given by

$$\tau = k_1 I_1^2 - k_2 I_2^2$$

Where I_1 = Current in operating coil

I_2 = Current in restraining coil

At the end of operation $\tau = 0$

$$k_1 I_1^2 = k_2 I_2^2$$

$$\Rightarrow \frac{I_1}{I_2} = \sqrt{\frac{K_2}{K_1}} = \text{Constant}$$

The operating characteristic is shown in the figure.

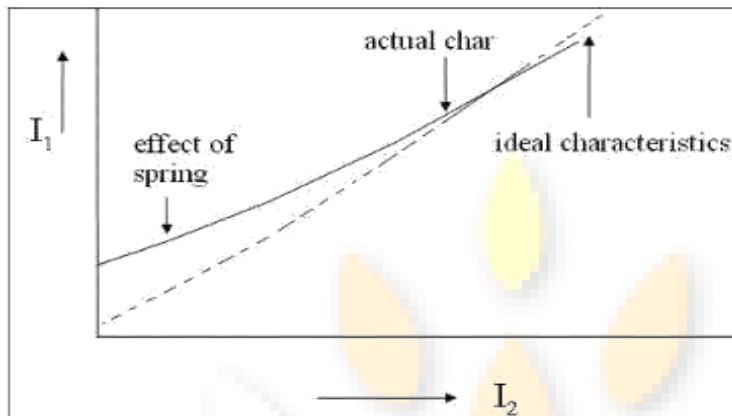

The curve is straight line, which is slightly tilted due to effect of spring. Balanced beam relay is difficult to design for large current because force is proportional to restraining current I_2 .

Induction Disc Relay

Induction Disc Relay has two types of constructions – shaded pole type induction disc relay and watt metric type induction disc relay.

Shaded – pole type disc relay

Simple construction of shaded – pole type disc relay is shown in figure 3.3(a) where as actual construction used practically is shown in figure 3.3(b).

Figure 3.3

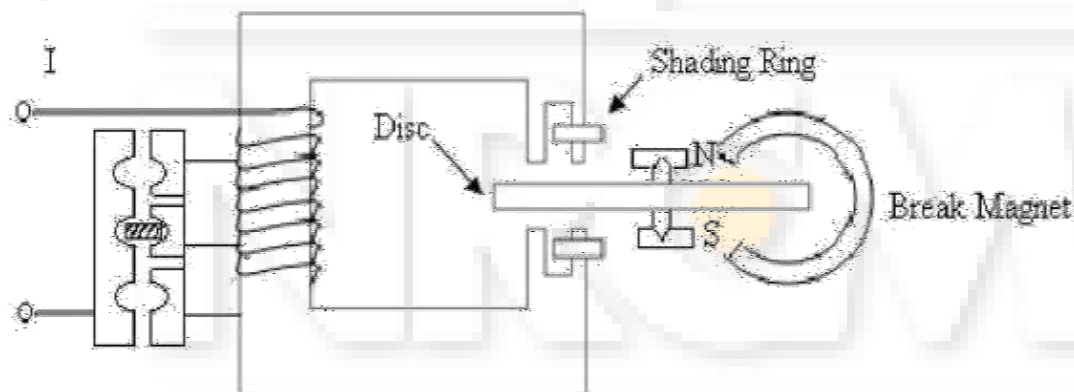

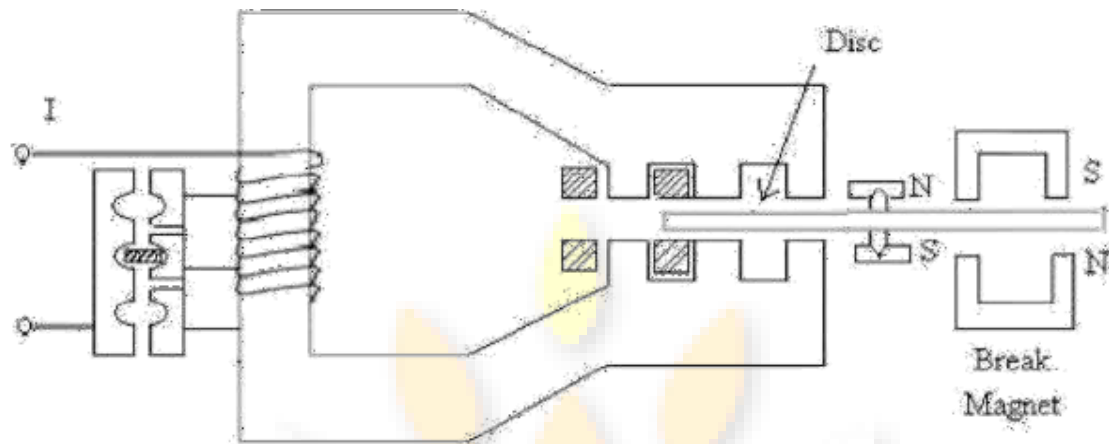

It consists of a disc shaped electromagnet made of aluminum and a c-shaped electromagnet. One half of each pole is surrounded by a copper ring known as shaded ring. The flux produced by the pole with shading ring is displaced in phase with that of flux developed by the pole with out shading ring. These two flux induces eddy currents in electromagnet. The flux produced by one pole interacts with the eddy current produced by the flux of another pole and produces electromagnetic torque which rotates the disc.

Watt metric type Induction relay:

The construction for watt metric type induction relay is shown in the figure 3.4 drawn below.

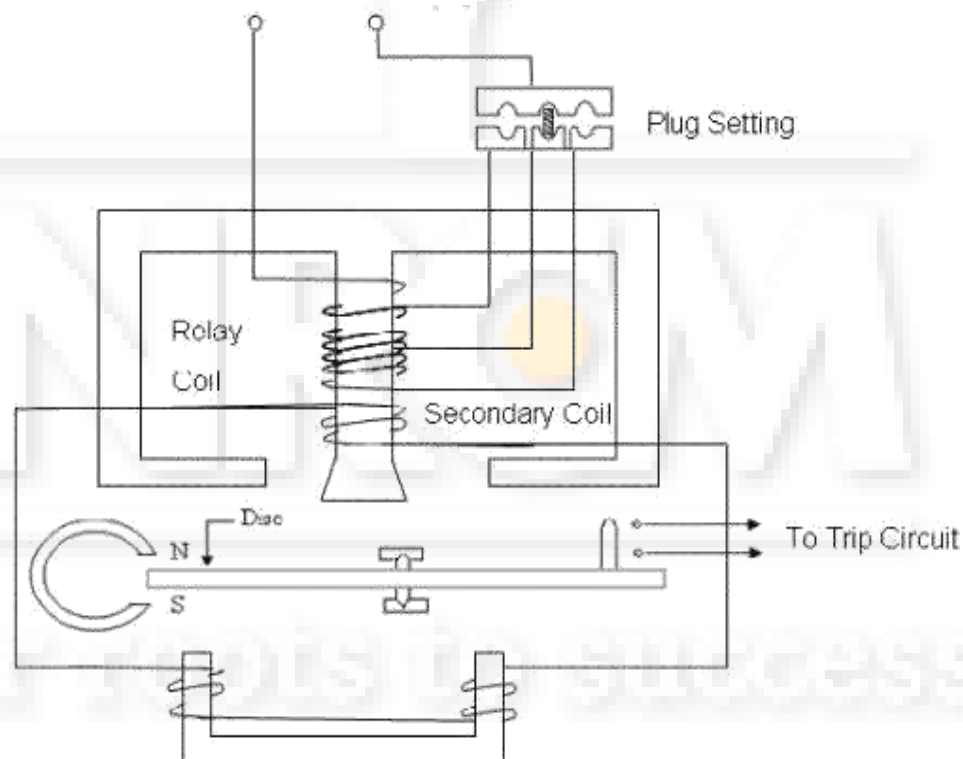

Figure 3.4

In this type of relay, there are two electromagnets wound with coils upper and lower one. These two coils are energized by two different supplies or a single supply with different resistance and reactance which causes phase displacement between two supplies.

The flux developed by each torque produces electromagnetic torque which tends to rotate the electromagnetic coil. The disc rotates at a speed proportional to the electromagnetic torque (or) driving torque. This driving torque is produced when operating current exceeds pick-up value; the disc remains stationary by the tension of the control spring.

Here we define two important settings for an induction disc relay.

Current Setting:

Current setting is provided by the tapping provided on coil. We can select a desired pick-up value by selecting a particular tapping.

Time Setting:

By adjusting the position of the back stop, the distance by which the disc travels before it closes the relay contact can be varied. If the back stop is advanced, the distance and hence operating time of the relay can be reduced.

Induction Cup relay:

Induction cup relay consists of an inverted cup (Rotor) which is a hollow as Linder. It is enclosed by a 4 or 8-pole structure. To decrease the air gap with out increasing inertia, a stationary iron core is placed inside the cup. An arm is attached to spindle of cup, so that when cup is rotated, the contacts opens or closes.

Two pairs of coils are wound around the poles shown in the figure 3.5.

Figure 3.5

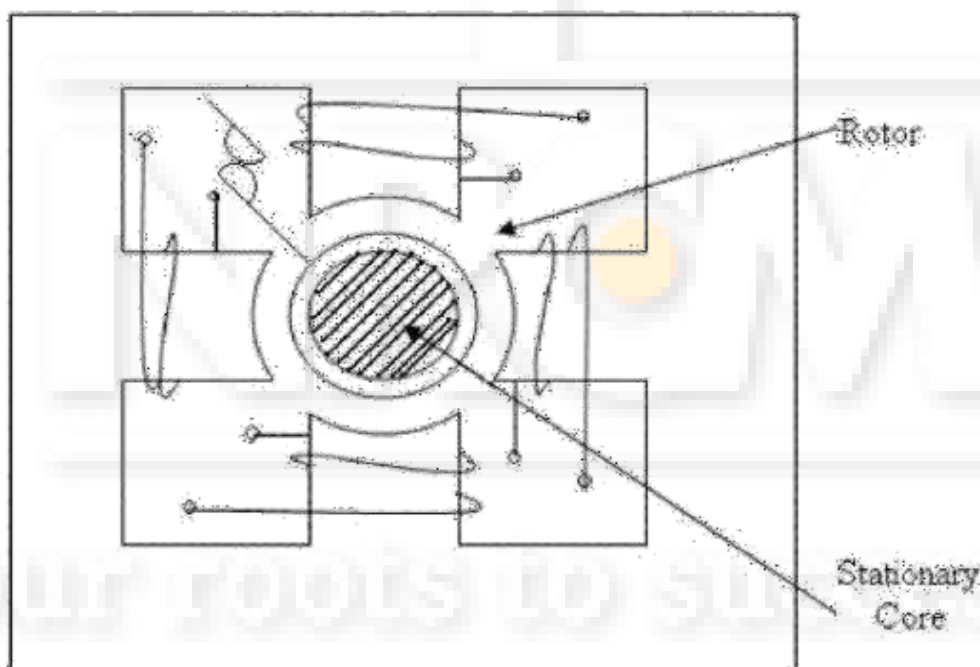

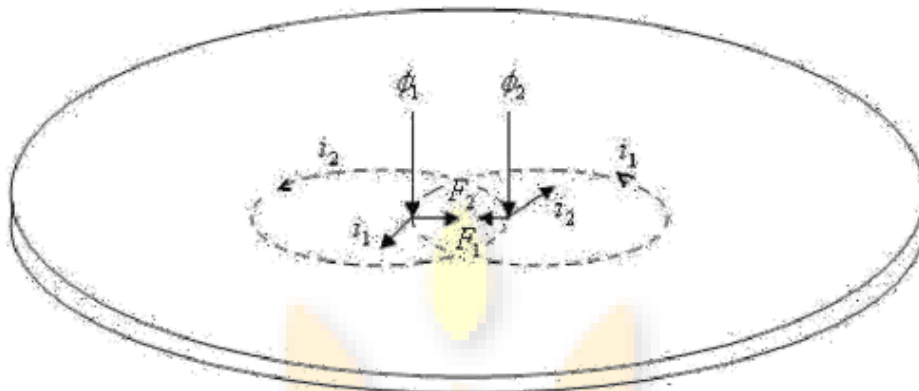

These currents produce flux which induces current in the cup. Due to the interaction of flux with the current, electromagnetic torque is developed which tends to rotate the cup and hence open or close the contacts.

The inertia of the cup is very much less. The magnetic leakage of the circuit is also less and hence this relay is more efficient. Its operating speed is also high. The dc transients in it are self eliminated. Magnetic saturation can be avoided in this type of relay.

Theory of Induction relay torque.

In both induction cup and disc relays, the force on the rotor is produced to interaction of one flux with the current produced by other flux.

If Φ_1 is flux produced by one coil and Φ_2 is flux produced by other coil with a phase difference of θ (i.e., Φ_2 leads Φ_1 by θ) they are expressed as

$$\phi_1 = \phi_{1m} \sin \omega t \text{ and}$$

$$\phi_2 = \phi_{2m} \sin(\omega t + \theta)$$

\therefore Voltage induced in the rotor

$$e_1 \propto \frac{d\phi_1}{dt} \\ \propto \phi_{1m} \cos \omega t$$

$$e_2 \propto \frac{d\phi_2}{dt} \\ \propto \phi_{2m} \cos(\omega t + \theta)$$

The eddy current induced in the rotor are in phase with their voltage.

$$\therefore i_1 \propto e_1 \propto \phi_{1m} \cos \omega t$$

$$i_2 \propto e_2 \propto \phi_{2m} \cos(\omega t + \theta)$$

The eddy current induced in the rotor are in phase with their voltage.

$$\therefore i_1 \propto e_1 \propto \phi_{1m} \cos \omega t$$

$$i_2 \propto e_2 \propto \phi_{2m} \cos(\omega t + \theta)$$

The torque or force produced in the rotor is proportional to the product of flux linking it and eddy current produced by other flux.

$$\therefore F_1 \propto \phi_1 i_2$$

$$\propto \phi_{1m} \sin \omega t \times \phi_{2m} \cos(\omega t + \theta)$$

$$F_1 \propto \phi_{1m} \phi_{2m} \sin \omega t \cdot \cos(\omega t + \theta)$$

$$\therefore F_2 \propto \phi_2 i_1$$

$$\propto \phi_{2m} \sin(\omega t + \theta) \times \phi_{1m} \cos \omega t$$

$$F_2 \propto \phi_{1m} \phi_{2m} \sin(\omega t + \theta) \cdot \cos \omega t$$

These forces act in opposite directions.

\therefore The net force

$$F = F_2 - F_1$$

$$\propto \phi_{1m} \phi_{2m} \sin(\omega t + \theta) \cdot \cos \omega t - \phi_{1m} \sin \omega t \times \phi_{2m} \cos(\omega t + \theta)$$

$$\propto \phi_{1m} \phi_{2m} [\sin(\omega t + \theta - \omega t)]$$

$$\propto \phi_{1m} \phi_{2m} \sin \theta$$

ϕ_{1m} , ϕ_{2m} are taken as ϕ_1 , ϕ_2 respectively. Where ϕ_1 and ϕ_2 are rms values

Then,

$$F = k \phi_{1m} \phi_{2m} \sin \theta$$

$$= k \phi_1 \phi_2 \sin \theta$$

If ϕ_1 and ϕ_2 are produced by same current I, then

$$\phi_1 \propto I$$

$$\phi_2 \propto I$$

$$\Rightarrow F = kI \times I \sin \theta$$

$$= kI^2 \sin \theta$$

If two different currents I_1 and I_2 produce flux ϕ_1 and ϕ_2 , then

$$F = kI_1 I_2 \sin \theta$$

3.3 CLASSIFICATION OF RELAYS

Relays are also classified on the basis of their time-current characteristics.

Instantaneous Relay

When the actuating quantity exceeds its pick-up value then the instantaneous relay operates in a definite time. The operating time is constant and is independent of magnitude of current. It is a very fast acting relay and there is no time delay in its operation.

Definite – time over current Relay:

A definite – time relay operates at a predetermined time when the actuating quantity exceeds its pick-up value. Assuming the actuating quantity as current, the time – current characteristic of a definite – time over current relay is shown in the figure 3.6(a)

Figure 3.6

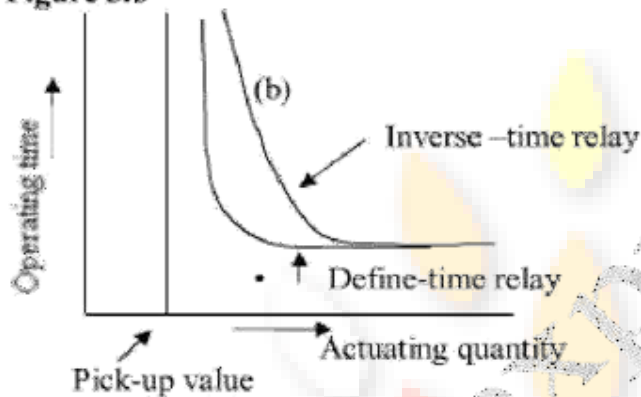

The predetermined definite time is set up by a time – delay mechanism.

Inverse – time relay:

Inverse – time relay operates when the actuating quantity exceeds pick – up value. The operating time depends upon the actuating quantity. If the actuating quantity (eg: current) increases, then the current decreases and vice-versa. The inverse time characteristics is shown in the figure 3.6(b)

Inverse Definite Minimum Time Over current (I.D.M.T) Relay:

I.D.M.T Relay acts as inverse – time relay for low values of fault current and as definite – time relay for high value of fault current. If the plug setting multiplier is below 10, it shows inverse – time characteristics.

3.4. DIRECTIONAL RELAY:

A Directional Relay can be formed from an over current relay by adding a directional element to it. The directional relay operates, only when the current exceeds the pick – up value in only one direction. If the power flow is opposite to the specified direction, the directional relay does not operate. The directional relay does not measure the magnitude of the power flow, but it senses the direction of the power flow.

The figure drawn below shows electromagnetic induction disc type directional relay.

Figure 3.7(a)

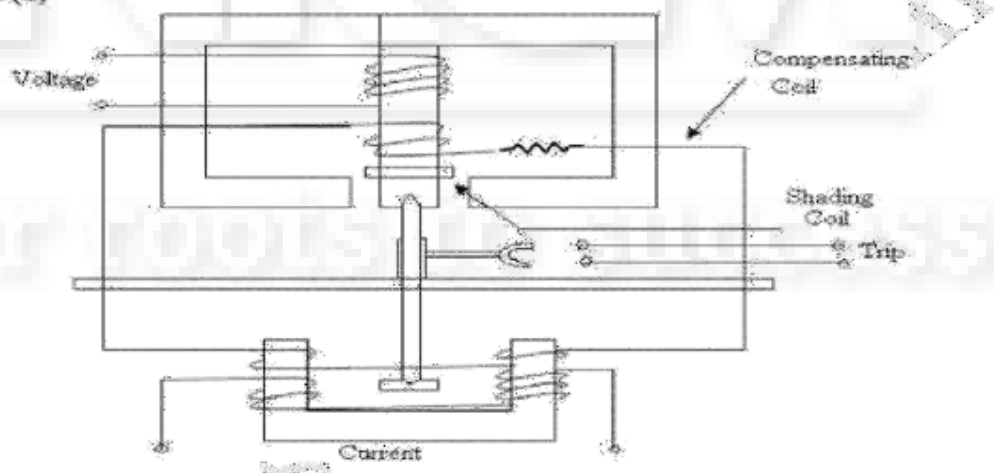

It is energized two quantities current I (operating quantity) and voltage V (restraining quantity). The V and I sets up flux Φ_1 and Φ_2 respectively in the disc. Eddy current produced by Φ_1 interacts with Φ_2 and produces a torque. Similarly, eddy current produced by Φ_2 interact with Φ_1 also produces a torque. This torques tends to rotate the disc. Let the current in the voltage coil be I_2 which lags the voltage V by 90° . The load current I_1 lags the voltage V by ϕ .

Therefore the angle between I_1 and I_2 is $\theta = 90^\circ - \phi$, the phasor diagram is shown below.

Figure 3.7 (b)

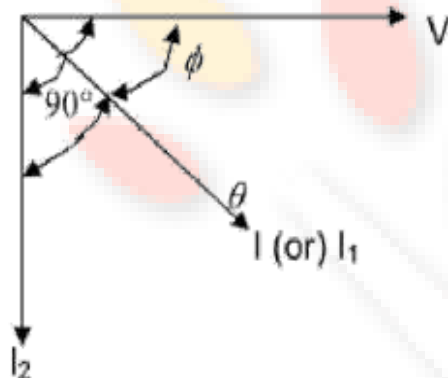

\therefore Torque produced is given by

$$\begin{aligned} \tau &\propto I_1 I_2 \sin \theta \\ &\propto I_1 I_2 \sin(90^\circ - \phi) \\ &\propto I_1 I_2 \cos \phi \\ \tau &\propto VI \cos \phi \end{aligned}$$

\therefore Maximum torque is produced when

$$\cos \phi = 1 \Rightarrow \phi = 0$$

i.e., the voltage and current are in phase with each other.

Directional over Current Relay:

The figure drawn below shows directional over current relay.

Figure 3.8

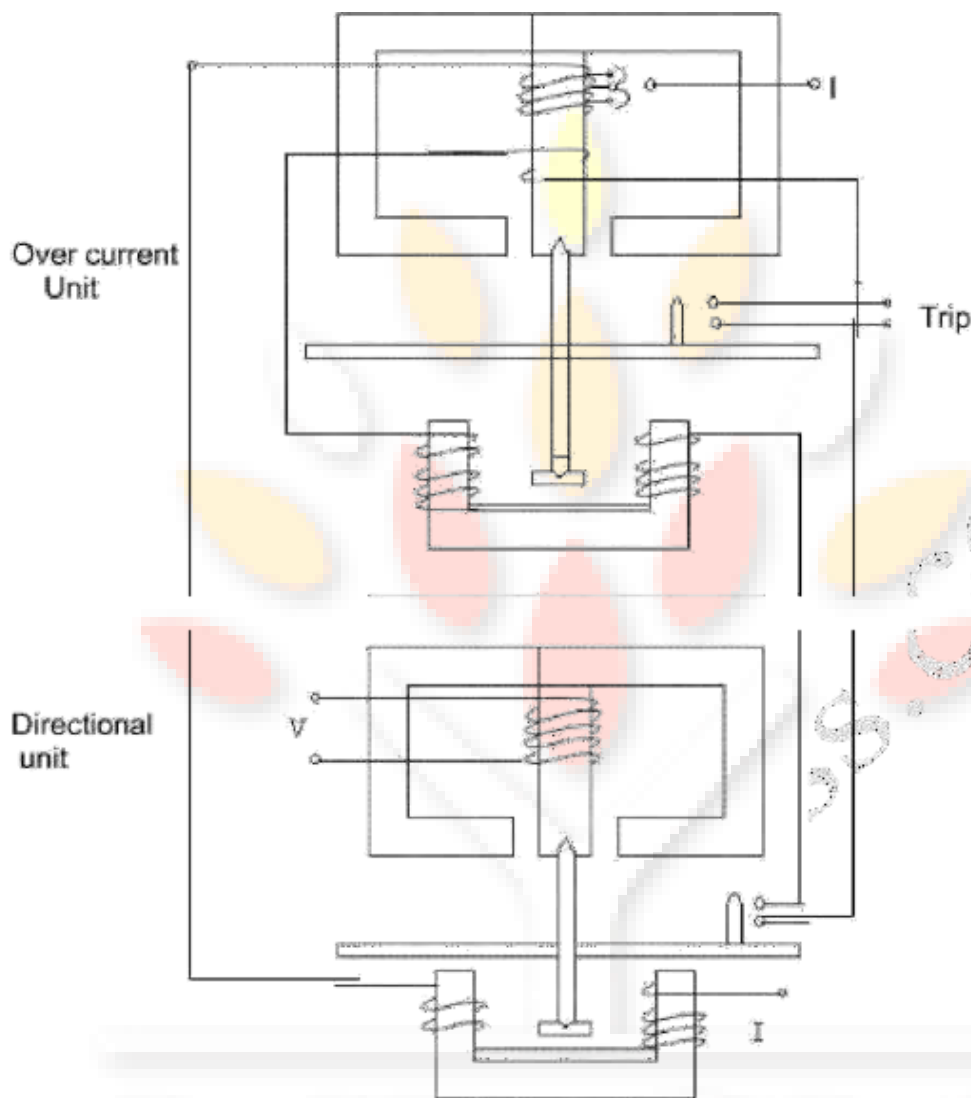

In this a over current relay is used in conjunction with directional relay. The secondary winding of over current relay is kept open. When the directional relay operates, it closes the contacts of the secondary winding of the over current unit. Thus the directional feature is given to the over current relay.

Differential Relay:

A differential relay is one which responds to the vector difference between two or more similar electrical quantities. For example, a differential relay responds to the vector difference of two currents I_1, I_2 i.e., magnitude $|\bar{I}_1 - \bar{I}_2|$ and phase angle difference $\angle(\bar{I}_1 - \bar{I}_2)$, so differential protection needs two actuating quantities.

Operating Principle:

The operating principle can be explained by considering the circulating differential protection of generators or transformers. The figure below shows the one with no internal fault.

Figure 3.9(a)

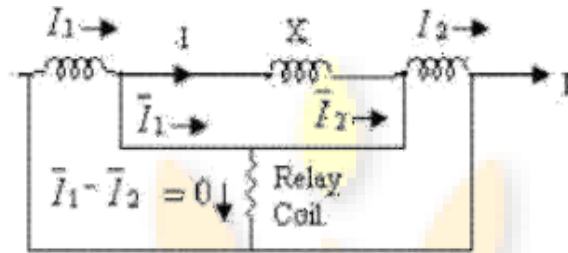

X is the winding of the machine to be protected. The current entering the winding is in phase with the current leaving the winding when there are no internal faults. The ratio of CT is such that the secondary currents of CT I_1 and I_2 are equal at normal conditions. I_1 and I_2 flow in same direction in pilot wires, connected during no internal fault. A relay coil is at the middle of the pilot wire. The relay is of over current type.

Since I_1 and I_2 are equal at normal conditions. $I_1 - I_2 = 0$
 When there is some internal fault as shown in the figure $I_1 \neq I_2$

$\therefore I_1 - I_2 \neq 0$
figure 3.9(b)

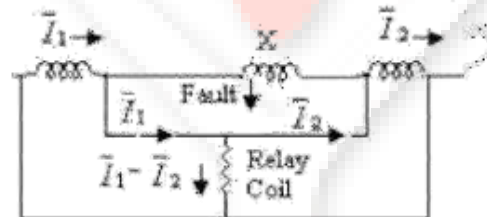

The current ($I_1 - I_2$) flows through the operating coil of relay. When this current is such that operating torque is greater than restraining torque then the relay operates.

Percentage differential relay:

To avoid problems due to external short circuits in differential relay an additional restraining coil is connected in pilot wire in the differential protection as shown in the figure.

Figure 3.10

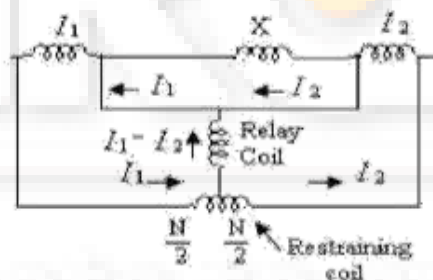

The restraining coil is connected such that the operating coil is connected to middle of the restraining coil. The total ampere turns is the sum of ampere turns of two halves.

$$\text{i.e. total ampere turns} = \frac{I_1 N}{2} + \frac{I_2 N}{2}$$

$$= \left(\frac{I_1 + I_2}{2} \right) N$$

∴ Average restraining current = $\left(\frac{I_1 + I_2}{2} \right)$ in N turns

If there is an external fault then I_1 and I_2 increases, so that the average restraining current increases. When restraining torque becomes more than the operation, The characteristics of percentage differential relay is shown below.

Figure 3.11

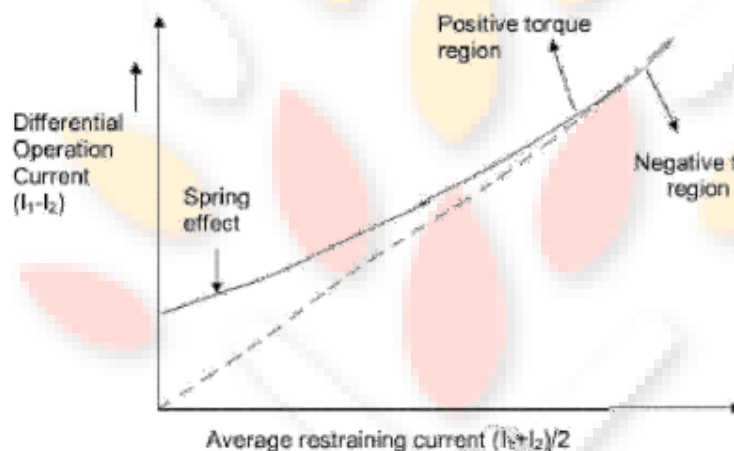

The ratio of the differential operating current to average restraining current is a fixed percentage. Therefore the relay is also called percentage differential relay. It is also called biased differential relay.

3.5 APPLICATION OF RELAY:

Over Current Relay:

An over current relay is the relay which operates when the magnitude of current exceeds a pick up level. Over current relays are of following types.

1. Instantaneous over current relay
2. Definite – time over current relay
3. Inverse – minimum time over current relay
4. Inverse Definite minimum time over current relay

Over current relay protects the system from over loads, short circuits such as 3-phase faults, earth faults etc.,

Applications:

An over current relay has wide range of applications. They are

1. Motor Protection:

Over current relay is used for the protection of motor against over loads, short circuits in stator windings.

2. Transformer protection:

Transformer is protected against faults using over current relay in addition with differential relay.

3. Line protection:

The lines can be protected by using instantaneous, inverse time, directional over current relays.

4. Protection of utility equipment:

The industrial, commercial and domestic equipment can be protected using over current relays.

3.5.2 Directional Relay:

A Directional Relay can be formed from an over current relay by adding a directional element to it. The directional relay operates, only when the current exceeds the pick-up value in only one direction. If the current or power flow is in opposite direction, the directional relay does not operate.

The directional relay does not measure the magnitude of the power flow, but it senses the direction of the power flow.

Applications:

Directional relay is used where the selectivity can be achieved by directional relaying. Some of the applications of directional relay are

1. In feeders:

Directional relay set in feeders is used to regulate power flow in certain directions.

2. In generators:

Directional relays are used in reverse power protection of generator. The directional relay operates when the power flow is in opposite direction to that of normal power flow.

3.5.3 Differential relay:

A Differential relay is one which responds to the vector difference between two or more similar electrical quantities.

For example, the differential relay responds to the vector difference of two currents I_1 , I_2 i.e. magnitude and phase angle difference $|\bar{I}_1 - \bar{I}_2|$ and $\angle \bar{I}_1 - \bar{I}_2$ respectively. Hence differential relay needs two actuating quantities.

Applications:

1. Protection of Transformers
2. Protection of generators
3. Protection of Transmission line
4. Protection of feeders
5. Protection of large motors
6. Bus – zone protection

Distance Relays:

Distance protection is the protection and High Voltage (HV) and Extra High Voltage (EHV) transmission lines. It employs a number of distance relays. Each distance relay measures the impedance of the line from the fault point to the location of relay. Since the impedance is proportional to the line-length which in turn depends on the distance, the relay is called distance relay.

The distance protection provides both primary and back-up protection. Various types of distance relays are

- i. Impedance Relay
- ii. Reactance Relay
- iii. MHO Relay
- iv. Quadrilateral Relay
- v. Elliptical Relays
- vi. Angle impedance Relays

Here we discuss only first three types of relays.



NRCM

YOUR ROOTS TO SUCCESS...

3.6. IMPEDANCE RELAY:

An Impedance relay measures the impedance of the line from fault point to the point of location of relay. This impedance is proportional to the distance of the relay from the fault point. Impedance includes both resistance and reactance.

Operating Principle:

The Operating torque of an electromagnetic impedance relay is the sum of torques due to current, voltage and control-spring. Current produces operating torque (positive) and voltage produces restraining torque (negative).

$$\therefore \tau = K_1 I^2 - K_2 V^2 - K_3$$

where K_1 , K_2 and K_3 are constants.

Since K_3 is very small, it is neglected

$$\tau = K_1 I^2 - K_2 V^2$$

For the relay to operate

Operating torque > restraining torque

$$\therefore K_1 I^2 > K_2 V^2$$

$$\Rightarrow \frac{V^2}{I^2} < \frac{K_1}{K_2}$$

$$\Rightarrow \frac{V}{I} < K$$

$$\Rightarrow Z < K \text{ ————— (1)}$$

For static or micro processor based impedance relays

$$K_1 I > K_2 V$$

$$\Rightarrow \frac{V}{I} < K$$

$$\Rightarrow Z < K \text{ ————— (2)}$$

From both equation (1) and (2),

We can say that the relay operates only when the measured impedance is less than the given constant.

Characteristics:

The $V - I$ characteristics of impedance relay is shown in the graph drawn below.

Figure 3.12

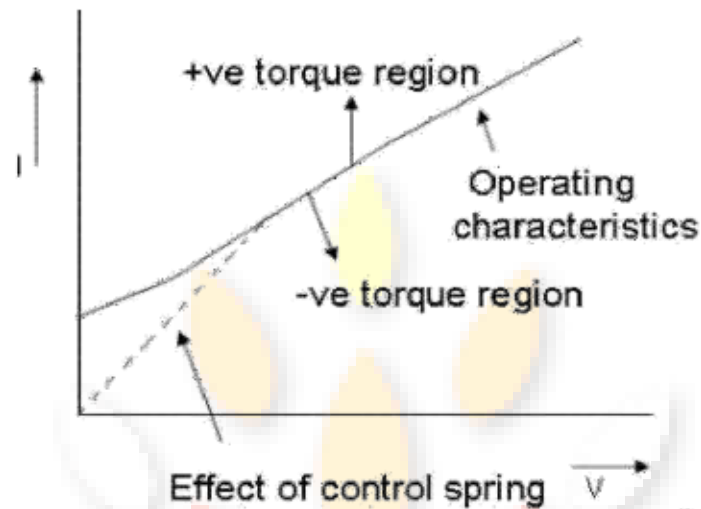

The graph is bent slightly at origin in electromagnetic relay due to the effect of control spring. For static and micro processor based relays the characteristics is a straight line.

Another way of representation of characteristics is by R-X diagram, as shown in the figure drawn below.

Figure 3.13

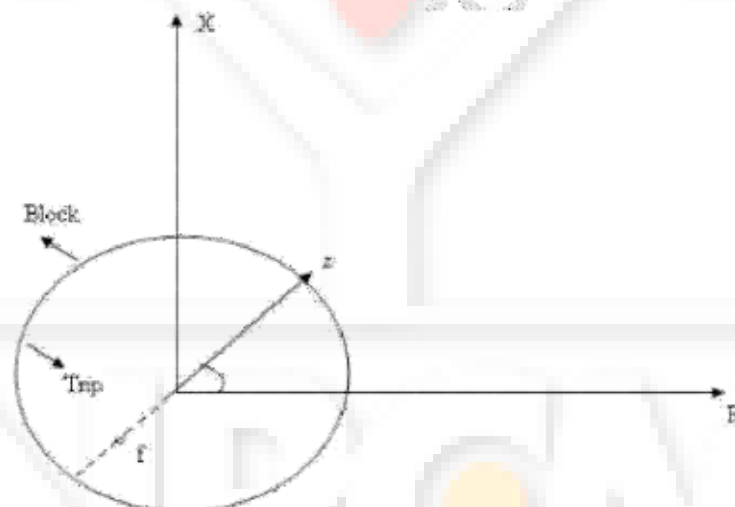

The circle shown in the above figure represents $z = k$ and outside the circle $z > k$ and inside the circle $z < k$. Φ is the phase angle between V and I . The operation of relay does not depend on Φ but depends only on the value of z . k is equal to the impedance of the line to be protected. If value of z is less than k it means fault point lies in the zone of relay and the relay operates and sends a trip signal. If value of z is greater than k , then the relay does not operate and it is in block mode i.e. fault point does not lies in into zone of operation.

Directional unit used with impedance relay:

An impedance relay without directional relay operates when the fault is in any direction i.e. either forward or backward. But when directional unit is used, the relay is

made to operate only when the fault is in specified direction. At any location, three impedance relays and a directional relay is employed. Directional relay is connected in series with the three impedance relay is shown in the figure drawn below.

Figure 3.14

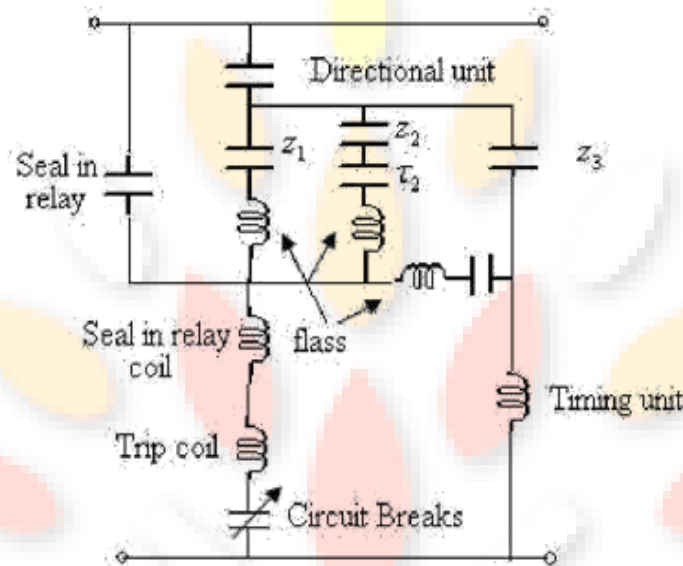

t_2 and t_3 are the contacts of the timer for the second and third units. The characteristics of three-zone impedance relay with directional unit are shown in figure drawn below.

Figure 3.15

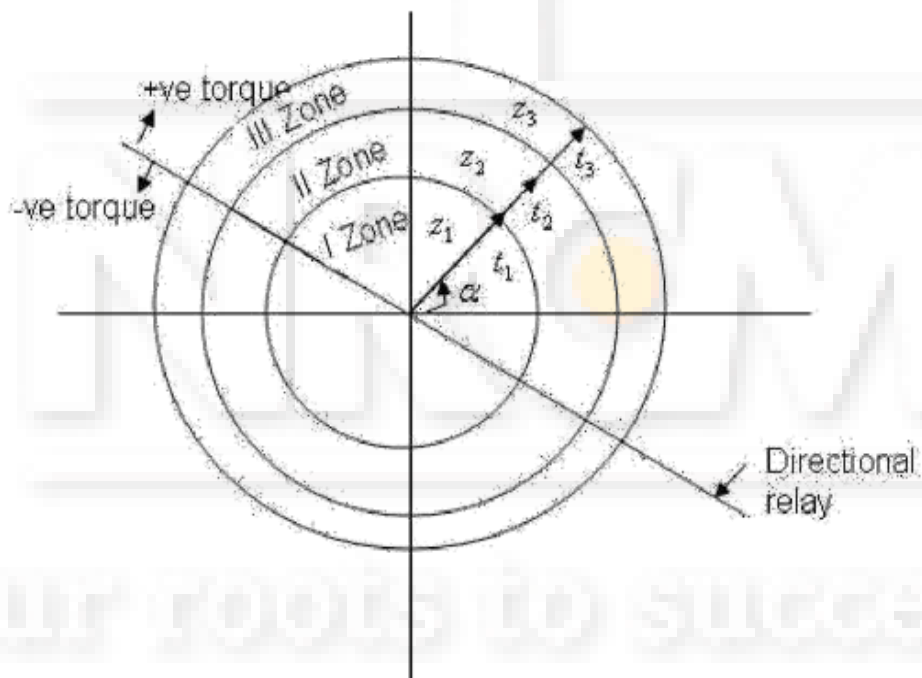

The characteristic circle is z_1 is smaller, z_2 is medium and z_3 is larger. t_1 , t_2 and t_3 are operating time for three relays.

The characteristic circle is z_1 is smaller, z_2 is medium and z_3 is larger. t_1 , t_2 and t_3 are operating time for three relays.

When a fault lies with in small circle and in the region of directional relay, the z_1 operates at a time t_1 . When the fault lies outside z_1 but inside z_2 , then T_2 closes after time t_2 when the circuit breaker trips. If the fault lies inside z_3 but outside z_1 and z_2 , the circuit breaker trips after closure of contact T_3 at time t_3 . The circuit breaker auxiliary switch is a

normally closed switch. When the circuit breaker trips, the auxiliary switch is opened to prevent damage of battery. A seal in relay is used to protect of contacts of main relay.

Reactance Relay:

Similar to the impedance relay, reactance relay measures the reactance of the line between the relay location and fault point. The operation of this relay is independent of resistance but depends only on reactance of line.

Hence the operating characteristics of reactance relay on R-X diagram is a straight line parallel to R-axis as shown in the figure drawn below.

Figure 3.16

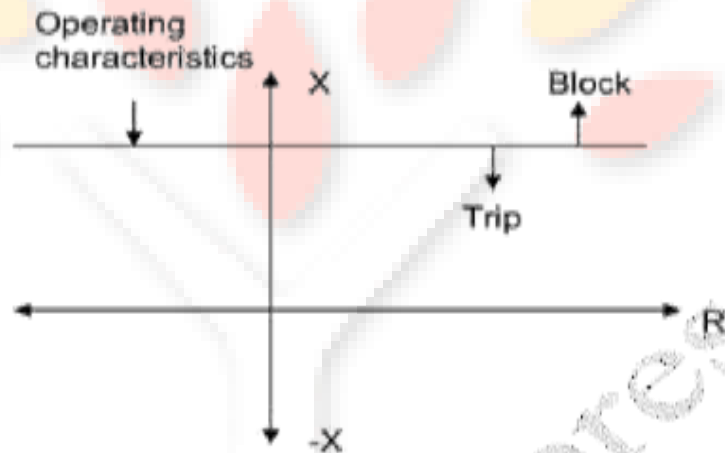

Induction – cup type reactance relay:

The figure drawn below shows Induction cup type reactance relay. The current produces polarizing flux in the upper, lower and right hand side poles. The flux in right hand side pole is out of phase with that of upper and lower poles due to its secondary winding closed through a phase shifting network.

The actuating quantity for left hand side pole is voltage through a phase shifting circuit.

There fore the polarizing flux interacts with right hand side pole to develop torque $K_1 I^2$ (operating torque) and the flux interacts with left hand side pole to develop torque $K_2 V \cos(90^\circ - \Phi)$.

There fore the total torque is given by $\tau = K_1 I^2 - K_2 V \cos(90^\circ - \Phi) - K_3$

Where K_3 is due to control spring.

For the relay to operate

Operating torque > Restraining torque

$$\therefore K_1 I^2 > K_2 V \cos(90^\circ - \Phi)$$

$$K_1 I > K_2 V \sin \Phi$$

$$\Rightarrow \frac{V}{I} \sin \Phi < \frac{K_1}{K_2}$$

$$\Rightarrow Z \sin \Phi < K$$

$$\Rightarrow X < K$$

Therefore the relay operates only when the reactance is less than a given constant.

The connections for a reactance relay using directional unit is shown in the figure drawn below.

Figure 3.17

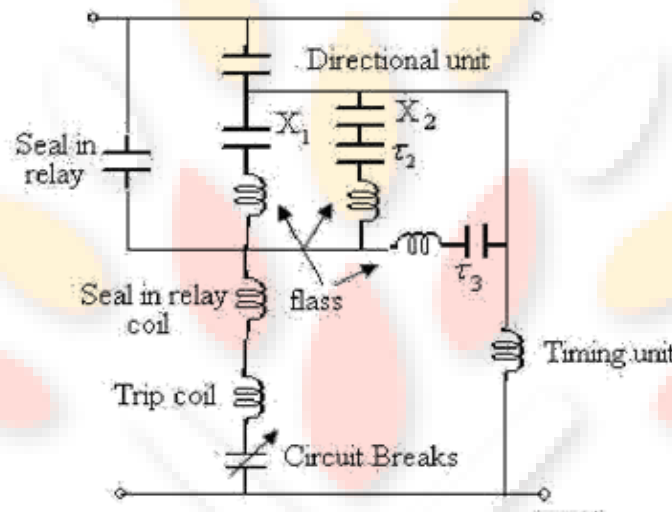

The characteristics diagram for the above reactance relay is shown below.

Figure 3.18

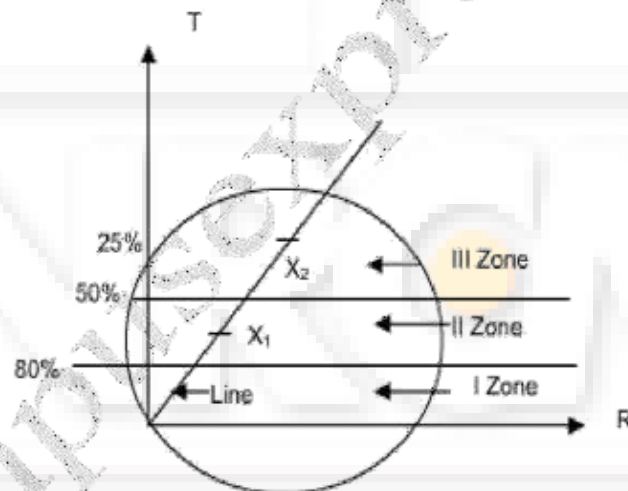

The circle represents the operating characteristics of directional unit. The unit I is used to protect 80 – 90% of the protected line. Unit II is used to protect 50% of the adjacent line. Unit III is a back – up protection for the whole adjacent line.

MHO Relay:

A MHO Relay or angle admittance relay measures a component of admittance $|y| \cos \theta$. It is a directional relay. The operating characteristics of MHO relay is a circle passing through origin when plotted in R-X diagram. When plotted in admittance diagram (G-B axes), its characteristics is a straight line.

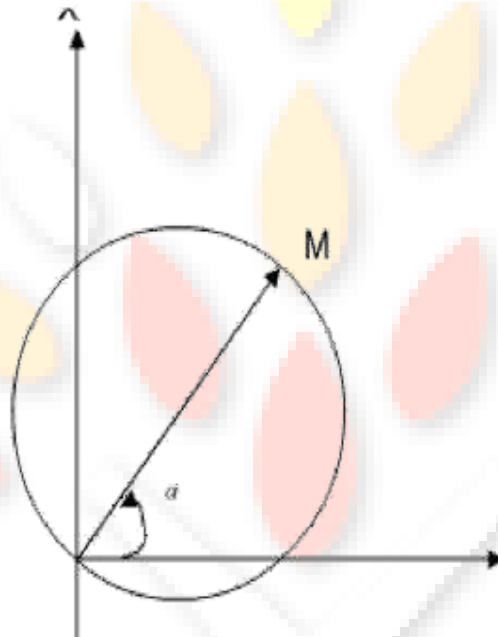

Electro magnetic MHO relay:

Electro magnetic induction cup type MHO relay is shown in the figure drawn below.

Figure 3.19

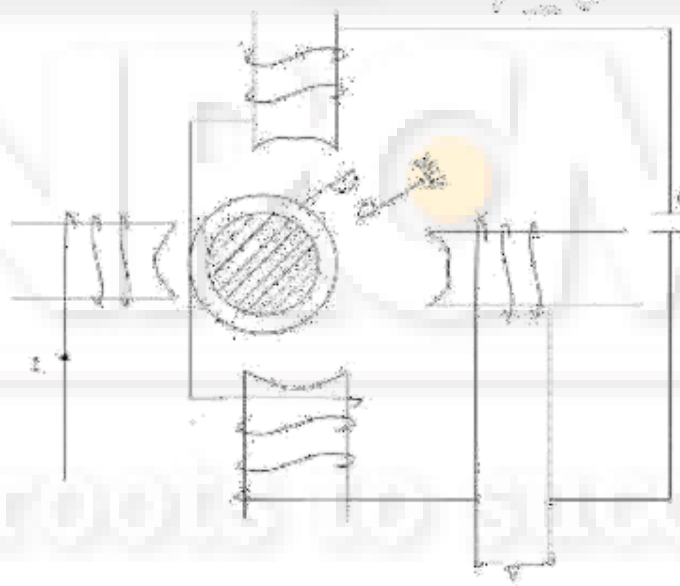

The upper and lower poles are energized by voltage. The left hand side pole is energized by actuating quantity current. The flux produced interacts with the polarizing flux to develop a torque $K_1 VI \cos(\Phi - \alpha)$ which is operating torque. The right hand side pole is energized by voltage V . The flux produced in right hand side pole interacts with the polarizing flux to develop restraining torque $K_2 V^2$. Therefore the net torque is

$$\tau = K_1 VI \cos(\Phi - \alpha) - K_2 V^2 - K_3$$

Where K_3 is torque due to control spring.

For the relay to operate

Operating torque > Restraining torque

$$\therefore K_1 VI \cos(\Phi - \alpha) > K_2 V^2$$

$$(I/V) \cos(\Phi - \alpha) > (K_2/K_1)$$

$$Y \cos(\Phi - \alpha) > K$$

$$\frac{1}{Y \cos(\Phi - \alpha)} < K$$

$$M < K$$

\therefore The relay operates when M is less than a given constant.

The connection of MHO relay with three units is shown in the figure drawn below.

Figure 3.20

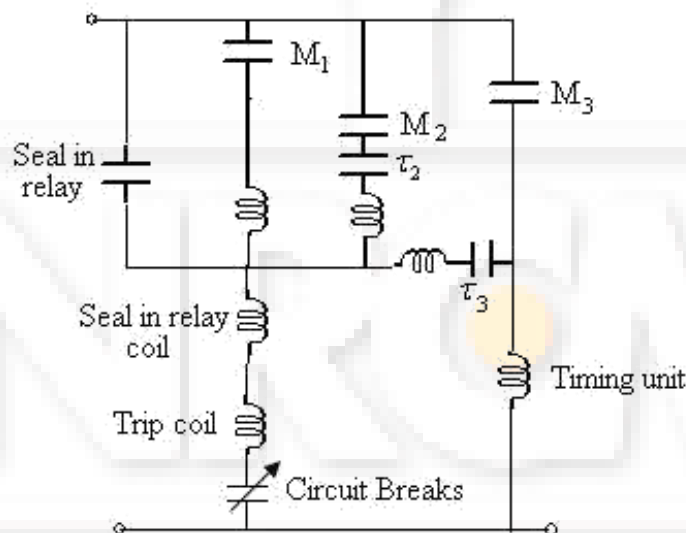

The operating characteristics for the above connection are shown in the figure drawn below.

Figure 3.21

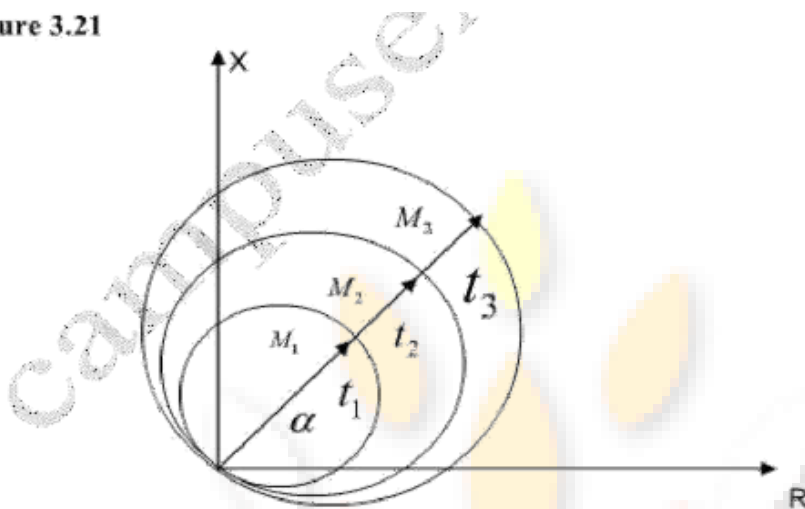

Unit I protects 80-90% of the protected section. Unit II protects 50% of the adjacent section. Unit III provides back-up protection.

Offset MHO Relay:

Offset MHO Relay can be realized using static MHO relay which is shown in figure below.

Figure 3.22

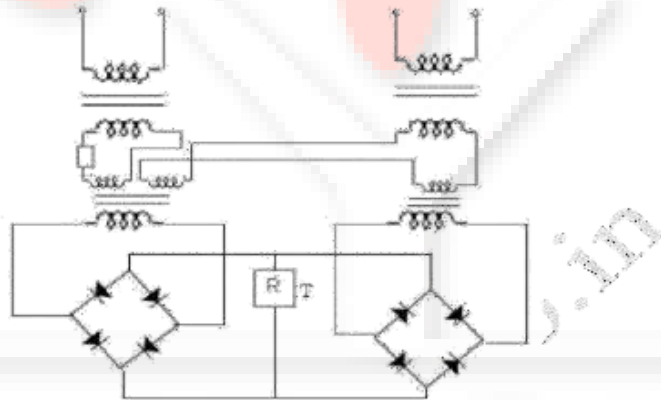

Here one actuating quantity is I (operating) and the other is $[(V/z_r) - nI]$ (restraining). Here n represents a fraction out put current of C.T is given to restrained circuit.

The relay operates only when

Operating quantity > Restraining quantity.

$$I > \left| \frac{V}{z_r} - nI \right|$$

Multiplying by z_r

$$|I z_r| > |V - nI z_r|$$

Dividing by z

$$|z_r| > \left| \frac{V}{I} - n z_r \right|$$

$$\Rightarrow |z_r| > |z - n z_r|$$

Therefore the characteristics of offset MHO relay is shown below.

Figure 3.23

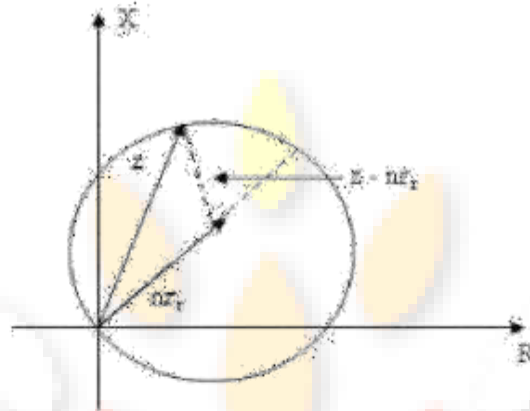

The typical offset value is 10% of protected line. When $V = 0$

$$I > |0 - nI|$$

Since n is a fraction. So the relay operates.

The offset characteristics of 3 unit relay is shown in the figure where unit III is offset MHO relay.

Figure 3.24

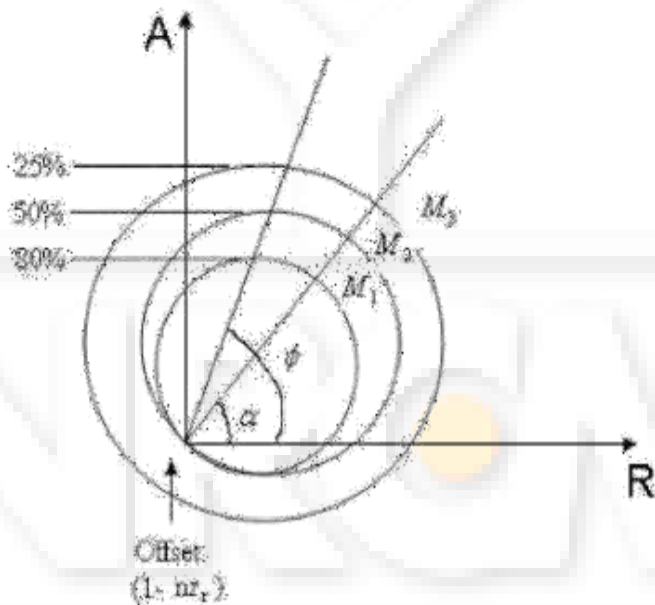

Notice that the characteristics of offset relay M_3 does not pass through origin. Unit III has following applications.

- i. Busbar zone back-up
- ii. Carrier starting unit
- iii. Power swing blocking

Comparison of characteristics of Distance Relay:

Impedance Relay:

Impedance relay is slightly affected by arc resistance as well as power and voltage surges. But it fails to detect a fault within 80% of protected line. Hence it is extensively used for medium lines for phase fault relay.

Reactance Relay:

Reactance relay is less affected by arc resistance and hence it is mainly used for ground fault relaying. It is also suitable for protection of short lines against phase faults. The main disadvantage of MHO relay is it is affected by power surges. So they are not suitable for longer lines since in long lines, power surges stays for a longer period.

MHO Relay:

MHO relay is less affected by power surges. MHO characteristics are best suited for protection of long lines against phase faults. But it is most affected by arc resistance.

3.7 STATIC RELAYS:

Static relay compares two electrical quantities using a static circuit and sends a tripping signal to the circuit breaker. The static circuit includes semiconductor diodes, transistors, thyristors, logic gates, diodes etc., static relays uses electromagnetic or dc polarized relays as slave relays. Slave relay do not actually measure the electrical quantity but it simply closed contact.

Static relays verses electromagnetic relays:

The advantages of static relays over electromagnetic are as follows;

1. Static relay is compact in size
2. Less maintenance is required
3. High resistance to shocks
4. Static relays consume less power. So it provides fewer burdens of potential transformers and current transformers.
5. There are no moving contacts.
6. A single static relay is used for several functions.
7. A static relay employs logic circuits. So it can do the process of reasoning.
8. It is used for remote back-up and network monitoring.

But the limitations of static relays are

1. The price of static relays is higher than the electromagnetic relays.
2. The device in the static circuit is very much affected by temperature.
3. Static devices such as thyristors are sensitive electro-static discharges (ESD).
4. The semi conductor devices are sensitive to voltage transients. So they may get damaged.

UNIT- III

PROTECTION OF POWER EQUIPMENT, TRANSFORMERS, LINES AND BUS BARS

Protection of Alternators

The generating units, especially the larger ones, are relatively few in number and higher in individual cost than most other equipments. Therefore, it is desirable and necessary to provide protection to cover the wide range of faults which may occur in the modern generating plant.

Some of the important faults which may occur on an alternator are:

- | | |
|-----------------------------|----------------------------|
| (i) failure of prime-mover | (ii) failure of field |
| (iii) overcurrent | (iv) Over speed unbalanced |
| (v) overvoltage | (vi) loading |
| (vii) stator winding faults | |

- (i) **Failure of prime-mover.** When input to the prime-mover fails, the alternator runs as a synchronous motor and draws some current from the supply system. This motoring condition is known as —inverted runningl.
- (a) In case of turbo-alternator sets, failure of steam supply may cause inverted running. If the steam supply is gradually restored, the alternator will pick up load without disturbing the system. If the steam failure is likely to be prolonged, the machine can be safely isolated by the control room attendant since this condition is relatively harmless. There-fore, automatic protection is not required.
- (b) In case of hydro-generator sets, protection against inverted running is achieved by providing mechanical devices on the water-wheel. When the water flow drops to an insufficient rate to maintain the electrical output, the alternator is disconnected from the system. Therefore, in this case also electrical protection is not necessary.
- (c) Diesel engine driven alternators, when running inverted, draw a considerable amount of power from the supply system and it is a usual practice to provide protection against motoring in order to avoid damage due to possible mechanical seizure. This is achieved by applying reverse power relays to the alternators which *isolate the latter during their motoring action. It is essential that the reverse power relays have time-delay in operation in order to prevent inadvertent tripping during system disturbances caused by faulty synchronizing and phase swinging.
- (ii) **Failure of field.** The chances of field failure of alternators are undoubtedly very rare. Even if it does occur, no immediate damage will be caused by permitting the alternator to run without a field for a short-period. It is sufficient to rely on the control room attendant to disconnect the faulty alternator manually from the system bus-bars. Therefore, it is a universal practice not to provide †automatic protection against this contingency.
- (iii) **Overcurrent.** It occurs mainly due to partial breakdown of winding insulation or due to overload on the supply system. Overcurrent protection for alternators is considered unnecessary because of the following reasons :
- (a) The modern tendency is to design alternators with very high values of internal impedance so that they will stand a complete short-circuit at their terminals for sufficient time without serious overheating. On the occurrence of an overload, the alternators can be disconnected manually.
- (b) The disadvantage of using overload protection for alternators is that such a protection might disconnect the alternators from the power plant bus on account of some

momentary troubles outside the plant and, therefore, interfere with the continuity of electric service.

- * During inverted running (or motoring), there is a reversal of power flow in the stator windings. This causes the operation of reverse power relay.
- † This is the case with attendant stations. However, in unattended stations, the use of a field-failure relay may be justified.

(iv) **Over speed.** The chief cause of over speed is the sudden loss of all or the major part of load on the alternator. Modern alternators are usually provided with mechanical centrifugal devices mounted on their driving shafts to trip the main valve of the prime-mover when a dangerous over speed occurs.

(v) **Over-voltage.** The field excitation system of modern alternators is so designed that over-voltage conditions at normal running speeds cannot occur. However, overvoltage in an alternator occurs when speed of the prime-mover increases due to sudden loss of the alternator load.

In case of steam-turbine driven alternators, the control governors are very sensitive to speed variations. They exercise a continuous check on over speed and thus prevent the occurrence of over-voltage on the generating unit. Therefore, over-voltage protection is not provided on turbo-alternator sets.

In case of hydro-generator, the control governors are much less sensitive and an appreciable time may elapse before the rise in speed due to loss of load is checked. The over-voltage during this time may reach a value which would over-stress the stator windings and insulation breakdown may occur. It is, therefore, a usual practice to provide over-voltage protection on hydro-generator units. The over-voltage relays are operated from a voltage supply derived from the generator terminals. The relays are so arranged that when the generated voltage rises 20% above the normal value, they operate to

- trip the main circuit breaker to disconnect the faulty alternator from the system
- disconnect the alternator field circuit

(vi) **Unbalanced loading.** Unbalanced loading means that there are different phase currents in the alternator. Unbalanced loading arises from faults to earth or faults between phases on the circuit external to the alternator. The unbalanced currents, if allowed to persist, may either severely burn the mechanical fixings of the rotor core or damage the field winding.

Fig. 22.1 shows the schematic arrangement for the protection of alternator against unbalanced loading. The scheme comprises three line current transformers, one mounted in each phase, having their secondaries connected in parallel. A relay is connected in parallel across the transformer secondaries. Under normal operating conditions, equal currents flow through the different phases of the alternator and their algebraic sum is zero.

Therefore, the sum of the currents flowing in the secondaries is also zero and no current flows through the operating coil of the relay. However, if unbalancing occurs, the currents induced in the secondaries will be different and the resultant of these currents will flow through the relay. The operation of the relay will trip the circuit breaker to disconnect the alternator from the system.

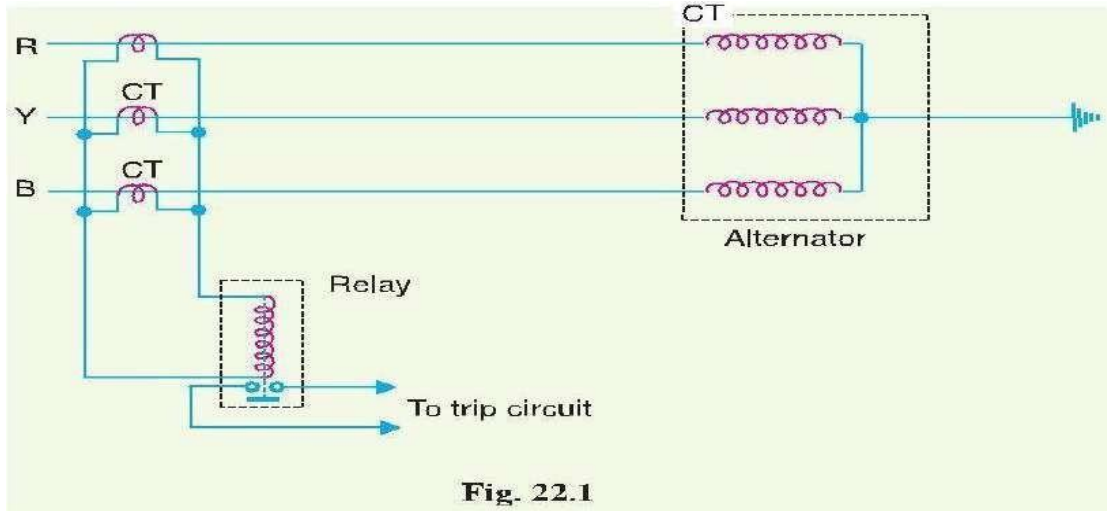

(i) **Stator winding faults.** These faults occur mainly due to the insulation failure of the stator windings. The main types of stator winding faults, in order of importance are:

- Fault between phase and ground
- Fault between phases
- Inter-turn fault involving turns of the same phase winding

The stator winding faults are the most dangerous and are likely to cause considerable damage to the expensive machinery. Therefore, automatic protection is absolutely necessary to clear such faults in the quickest possible time in order to minimize the extent of damage. For protection of alternators against such faults, differential method of protection (also known as Merz - Price system) is most commonly employed due to its greater sensitivity and reliability. This system of protection is discussed in the following section.

DIFFERENTIAL PROTECTION OF ALTERNATORS

The most common system used for the protection of stator winding faults employs circulating-current principle (Refer back to Art. 21.18). In this scheme of protection, currents at the two ends of the protected section are compared. Under normal operating conditions, these currents are equal but may become unequal on the occurrence of a fault in the protected section. The difference of the currents under fault conditions is arranged to pass through the operating coil of the relay. The relay then closes its contacts to isolate protected section from the system. This form of protection is also known as *Merz-Price circulating current scheme*.

SCHEMATIC ARRANGEMENT: Fig. 22.2 shows the schematic arrangement of current differential protection for a 3-phase alternator. Identical current transformer pairs CT_1 and CT_2 are placed on either side of each phase of the stator windings. The secondaries of each set of current transformers are connected in star; the two neutral points and the corresponding terminals of the two star groups being connected together by means of a four-core pilot cable. Thus there is an independent path for the currents circulating in each pair of current transformers and the corresponding pilot P .

- * If the stator winding fault is not cleared quickly, it may lead to
 - (i) burning of stator coils
 - (ii) burning and welding-up of stator laminations

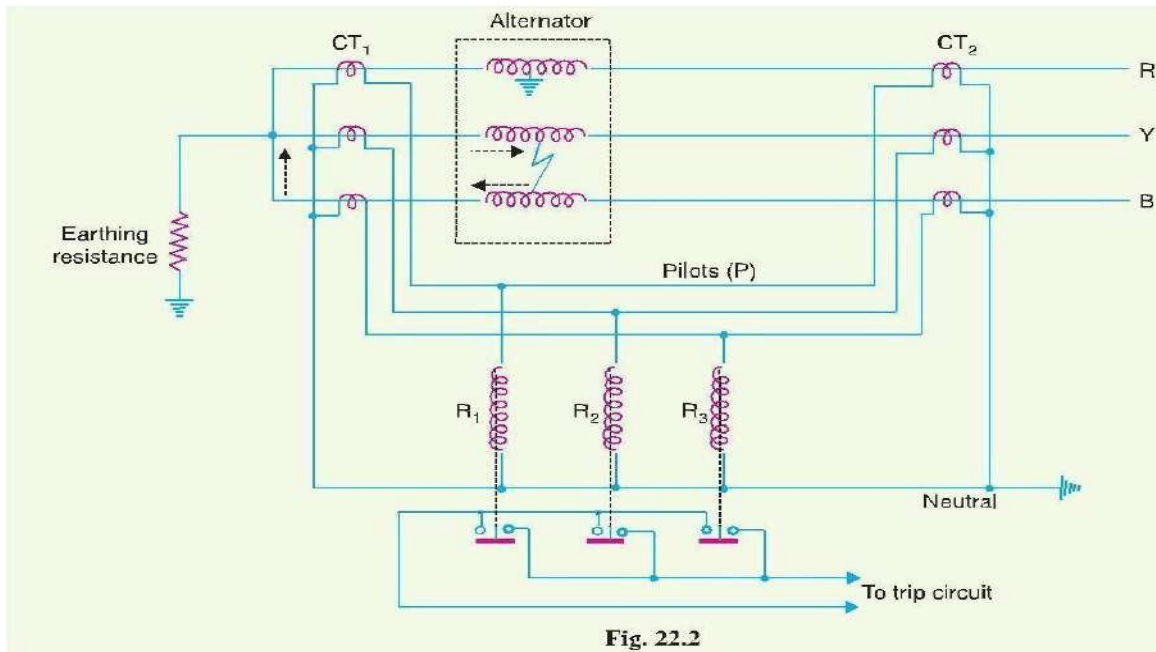

The relay coils are connected in star, the neutral point being connected to the current- transformer common neutral and the outer ends one to each of the other three pilots. In order that burden on each current transformer is the same, the relays are connected across equipotential points of the three pilot wires and these equipotential points would naturally be located at the middle of the pilot wires. The relays are generally of electromagnetic type and are arranged for instantaneous action since fault should be cleared as quickly as possible.

OPERATION:

Referring to above fig, it is clear that the relays are connected in shunt across each circulating path. Therefore, the circuit of Fig. 22.2 can be shown in a simpler form in Fig. 22.3. Under normal operating conditions, the current at both ends of each winding will be equal and hence the currents in the secondaries of two CTs connected in any phase will also be equal. Therefore, there is balanced circulating current in the pilot wires and no current flows through the operating coils (R_1 , R_2 and R_3) of the relays. When an earth-fault or phase-to-phase fault occurs, this condition no longer holds good and the differential current flowing through the relay circuit operates the relay to trip the circuit breaker.

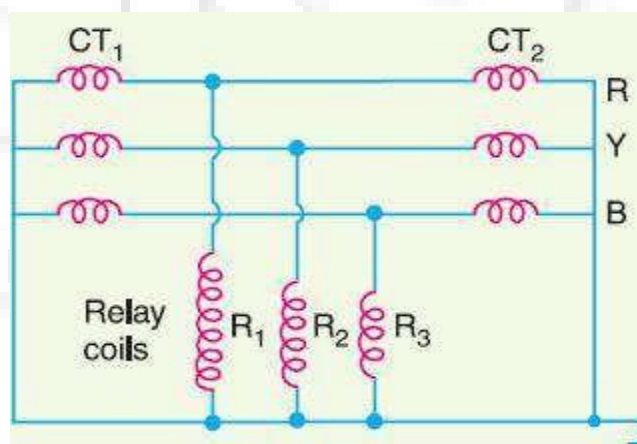

(i) Suppose an earth fault occurs on phase R due to breakdown of its insulation to earth as shown in Fig. 22.2. The current in the affected phase winding will flow through the core and frame of the machine to earth, the circuit being completed through the neutral earthing resistance. The currents in the secondaries of the two CTs in phase R will become unequal and the difference of the two currents will flow through the corresponding relay coil (*i.e.* $R1$), returning via the neutral pilot. Consequently, the relay operates to trip the circuit breaker.

(ii) Imagine that now a short-circuit fault occurs between the phases Y and B as shown in Fig. 22.2. The short-circuit current circulates *via* the neutral end connection through the two windings and through the fault as shown by the dotted arrows. The currents in the secondaries of two CTs in each affected phase will become unequal and the differential current will flow through the operating coils of the relays (*i.e.* $R2$ and $R3$) connected in these phases. The relay then closes its contacts to trip the circuit breaker.

It may be noted that the relay circuit is so arranged that its energizing causes

- (i) Opening of the breaker connecting the alternator to the bus-bars and
- (ii) Opening of the field circuit of the alternator.

It is a prevailing practice to mount current transformers $CT1$ in the neutral connections (usually in the alternator pit) and current transformers $CT2$ in the switch-gear equipment. In some cases, the alternator is located at a considerable distance from the switchgear. As the relays are located close to the circuit breaker, therefore, it is not convenient to connect the relay coils to the actual physical mid-points of the pilots. Under these circumstances, balancing resistances are inserted in the shorter lengths of the pilots so that the relay tapping points divide the whole secondary impedance of two sets of CTs into equal portions. This arrangement is shown in Fig. 22.4. These resistances are usually adjustable in order to obtain the exact balance.

LIMITATIONS:

- The two circuits for alternator protection shown above have their own limitations.
- It is a general practice to use neutral earthing resistance in order to limit the destructive effects of earth-fault currents.
- In such a situation, it is impossible to protect whole of the stator windings of a star-connected alternator during earth-faults. When an earth-fault occurs near the neutral point, there

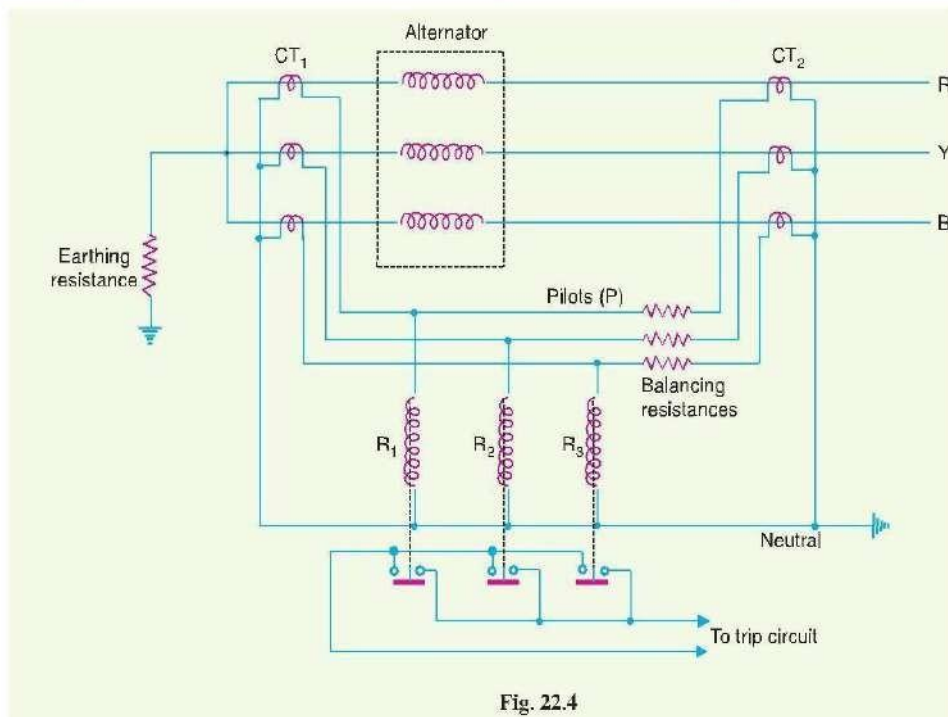

Fig. 22.4

may be insufficient voltage across the short-circuited portion to drive the necessary current round the fault circuit to operate the relay. The magnitude of unprotected zone depends upon the value of earthing resistance and relay setting.

Makers of protective gear speak of protecting 80% of the winding which means that faults in the 20% of the winding near the neutral point cannot cause tripping *i.e.* this portion is unprotected. It is a usual practice to protect only 85% of the winding because the chances of an earth fault occurring near the neutral point are very rare due to the uniform insulation of the winding throughout.

MODIFIED DIFFERENTIAL PROTECTION FOR ALTERNATORS

If the neutral point of a star-connected alternator is earthed through a high resistance, protection schemes shown in Fig. 22.2 or 22.4 will not provide sufficient sensitivity for earth-faults. It is because the high earthing resistance will limit the earth-fault currents to a low value, necessitating relays with low current settings if adequate portion of the generator winding is to be protected. However, too low a relay setting is undesirable for reliable stability on heavy through phase-faults. In order to overcome this difficulty, a modified form of differential protection is used in which the setting of earth faults is reduced without impairing stability.

The modified arrangement is shown in Fig. 22.5. The modifications affect only the relay connections and consist in connecting two relays for phase-fault protection and the third for earth-fault protection only. The two phase elements (PC and PA) and balancing resistance (BR) are connected in star and the earth relay (ER) is connected between this star point and the fourth wire of circulating current pilot-circuit.

OPERATION: Under normal operating conditions, currents at the two ends of each stator winding will be equal. Therefore, there is a balanced circulating current in the phase pilot wires and no current flows through the operating coils of the relays. Consequently, the relays remain inoperative.

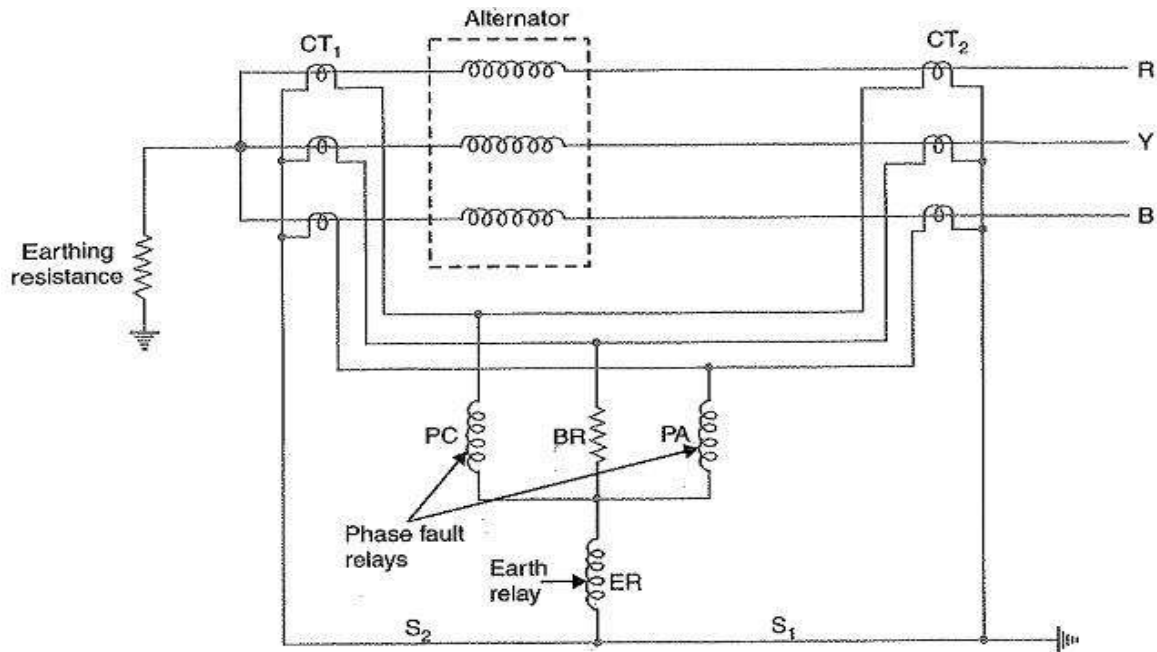

Fig. 22.5

If an earth-fault occurs on any one phase, the out-of-balance secondary current in CTs in that phase will flow through the earth relay *ER* and *via* pilot *S1* or *S2* to the neutral of the current transformers. This will cause the operation of earth relay only. If a fault occurs between two phases, the out-of-balance current will circulate round the two transformer secondaries *via* any two of the coils *PA*, *BR*, *PC* (the pair being decided by the two phases that are faulty) without passing through the earth relay *ER*. Therefore, only the phase-fault relays will operate.

BALANCED EARTH-FAULT PROTECTION

In small-size alternators, the neutral ends of the three-phase windings are often connected internally to a single terminal. Therefore, it is not possible to use Merz-Price circulating current principle described above because there are no facilities for accommodating the necessary current transformers in the neutral connection of each phase winding. Under these circumstances, it is considered sufficient to provide protection against earth-faults only by the use of balanced earth-fault protection scheme. This scheme provides no protection against phase-to-phase faults, unless and until they develop into earth-faults, as most of them will.

SCHEMATIC ARRANGEMENT: Fig. 22.6 shows the schematic arrangement of a balanced earth-fault protection for a 3-phase alternator. It consists of three line current transformers, one mounted in each phase, having their secondaries connected in parallel with that of a single current transformer in the conductor joining the star point of the alternator to earth. A relay is connected across the transformers secondaries. The protection against earth faults is limited to the region between the neutral and the line current transformers.

OPERATION: Under normal operating conditions, the currents flowing in the alternator leads and hence the currents flowing in secondaries of the line current transformers add to zero and no current flows through the relay. Also under these conditions, the current in the neutral wire is zero and the secondary of neutral current transformer supplies no

current to the relay. If an earth-fault develops at F_2 external to the protected zone, the sum of

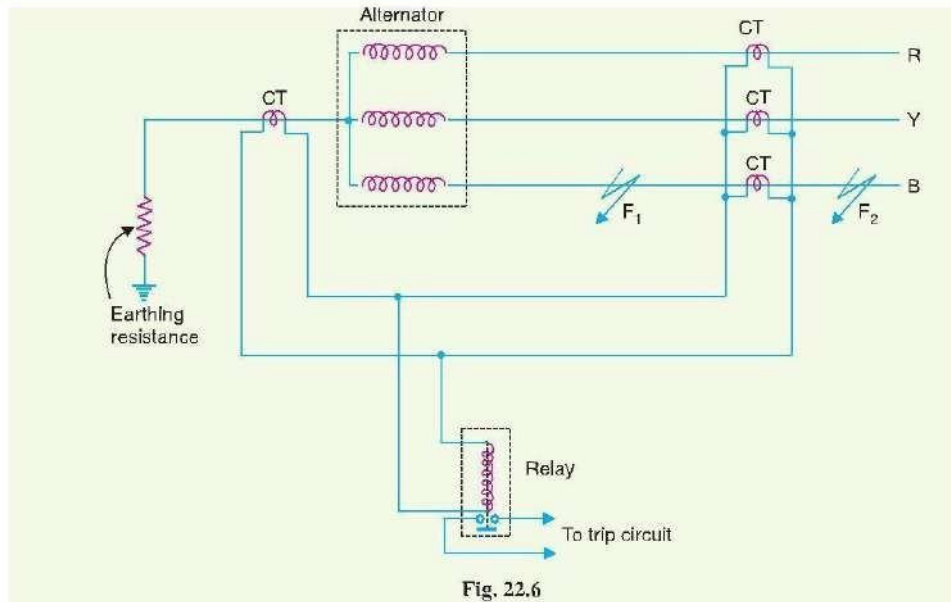

the currents at the terminals of the alternator is exactly equal to the current in the neutral connection and hence no current flows through the relay. When an earth-fault occurs at F_1 or within the protected zone, these currents are no longer equal and the differential current flows through the operating coil of the relay. The relay then closes its contacts to disconnect the alternator from the system.

STATOR INTER-TURN PROTECTION

Merz-price circulating-current system protects against phase-to-ground and phase-to-phase faults.

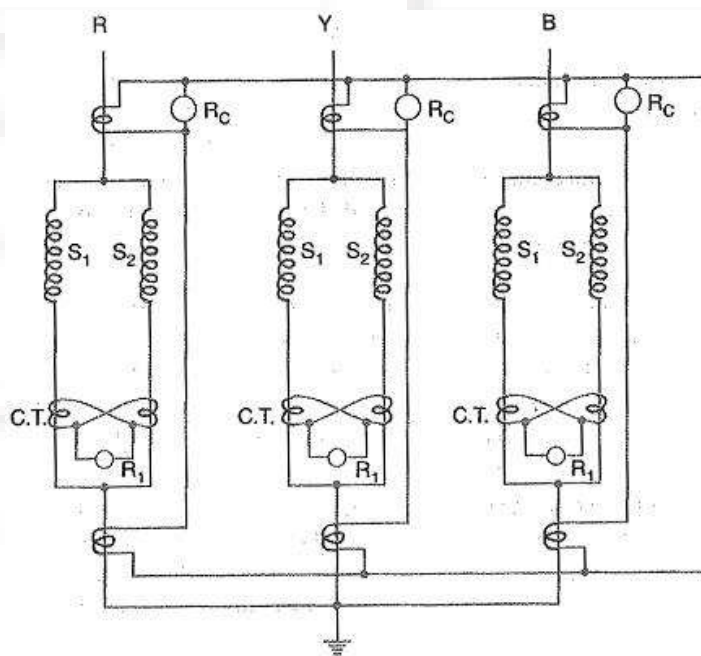

Fig. 22.7

It does not protect against turn-to-turn fault on the same phase winding of the stator. It is because the current that this type of fault produces flows in a local circuit between the turns involved and does not create a difference between the currents entering and leaving the winding at its two ends where current transformers are applied. However, it is usually considered unnecessary to provide protection for inter-turn faults because they invariably develop into earth-faults.

In single turn generator (*e.g.* large steam-turbine generators), there is no necessity of protection against inter-turn faults. However, inter-turn protection is provided for multi-turn generators such as hydro-electric generators. These generators have double-winding armatures (*i.e.* each phase winding is divided into two halves) owing to the very heavy currents which they have to carry. Advantage may be taken of this necessity to protect inter-turn faults on the same winding.

Fig. 22.7 shows the schematic arrangement of circulating-current and inter-turn protection of a 3-phase double wound generator. The relays RC provide protection against phase-to-ground and phase-to-phase faults whereas relays R1 provide protection against inter-turn faults.

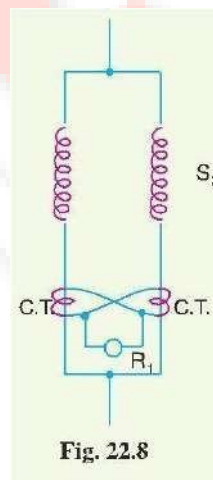

Fig. 22.8 shows the duplicate stator windings S1 and S2 of one phase only S₁ with a provision against inter-turn faults. Two current transformers are connected on the circulating-current principle. Under normal conditions, the currents in the stator windings S1 and S2 are equal and so will be the currents in the secondaries of the two CTs. The secondary current round the loop then is the same at all points and no current flows through the relay R1. If a short-circuit develops between adjacent turns, say on S1, the currents in the stator windings S1 and S2 will no longer be equal. Therefore, unequal currents will be induced in the secondaries of CTs and the difference of these two currents flows through the relay R1. The relay then closes its contacts to clear the generator from the system

TRANSFORMER PROTECTION

5.1 INTRODUCTION

The power transformer in the power system network is subjected to variety of faults. They include earth-faults, phase to phase faults, inter turns faults, over loading etc. So the transformer should be protected from these faults.

The choice of protection of a particular transformer depends upon its rating, size and whether it has no-load or off-load tap changer for the transformer of small rating, fuses or relays may be used but for large rating transformers are protected using percentage differential protection.

5.2 PERCENTAGE DIFFERENTIAL PROTECTION

As mentioned the percentage differential protection is employed for transformer of large ratings. The differential protection responds to vector difference between two similar actuating quantities. This protection is explained in the following points

1. Two C.T's (Current Transformers) are connected at each end of the transformers
2. Pilot wires are connected between the CT's
3. The CT's are connected in Star or Delta
4. Biased coils are provided in series with pilot wires to avoid unwanted operation
5. The ratio of CT's and its connections should be set, such that the current fed into the pilot wires or equal at normal conditions
6. When there is an internal fault in the transformer such as phase –ground or phase to phase fault, the current are not equal and the difference currents (I_1-I_2) flows through the operating coil of relay.
7. The current flowing through the bias coil is given by $\frac{I_1+I_2}{2}$. This current provides the restraining torque.
8. When operating torque > restraining torque then the relay operates.



YOUR ROOTS TO SUCCESS

Rules for CT Connections :

The CT connection should be such that at normal conditions or external faults, no current should flow through the operating coil of relay.

The Connection of CT Secondary on Star side and Delta side are shown in Figures drawn

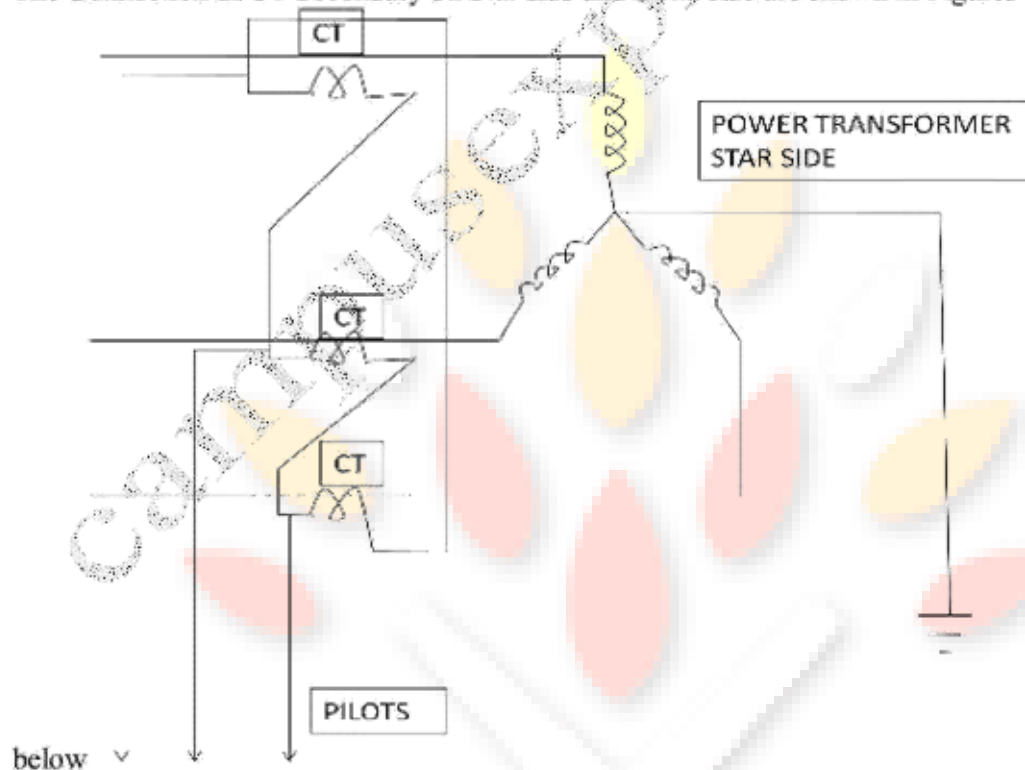

below v

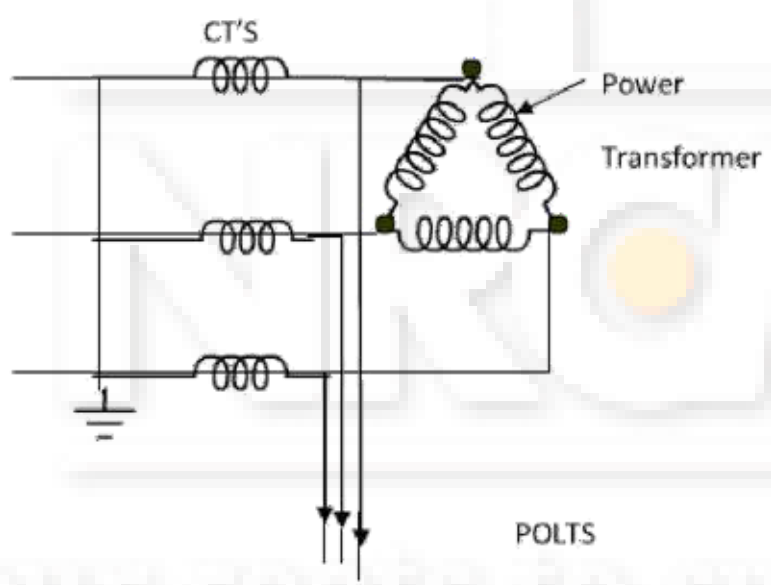

Fig 5.1(b) connection of CT secondary on delta side.

- * In a transformer, the load currents on H.V.side are displaced in phase with respect to the load currents on L.V side. This phase displacement induces phase displacement in CT Secondaries. So this phase displacement provided by Star/Delta connections of CT Secondaries, so that during normal operation the current fed to pilot wires from both sides are in phase with each other.
- * There are four different types of groups based on phase displacement.

	<u>Phase Displacement</u>
Group 1 : Star - Star	0°
Group 2 : Star - Star	180°
Group 3 : Delta - Star	-30°
Group 4 : Delta - Star	30°

The rules to be followed meet the above requirements is

- Secondaries of CT's on Star connected side are connected in Delta.
- Secondaries of CT's on delta connected side are connected in Star
- The neutral point of power transformer and CT Star are connected to ground
- Current transformer ratios should be such that the current fed into pilot wires from both ends should be same under normal conditions or external faults. CT's on both sides may have different ratings based on above condition.

For example , current fed into pilot wires is 10Amp, the secondary current of Star connected CT should be 10 Amp and that of delta connected CT should be $10/\sqrt{3}$ Amp.

NRCM

YOUR ROOTS TO SUCCESS...

The relevant diagrams for percentage differential protection of delta-star and star-star connected transformer is shown in figures drawn below.

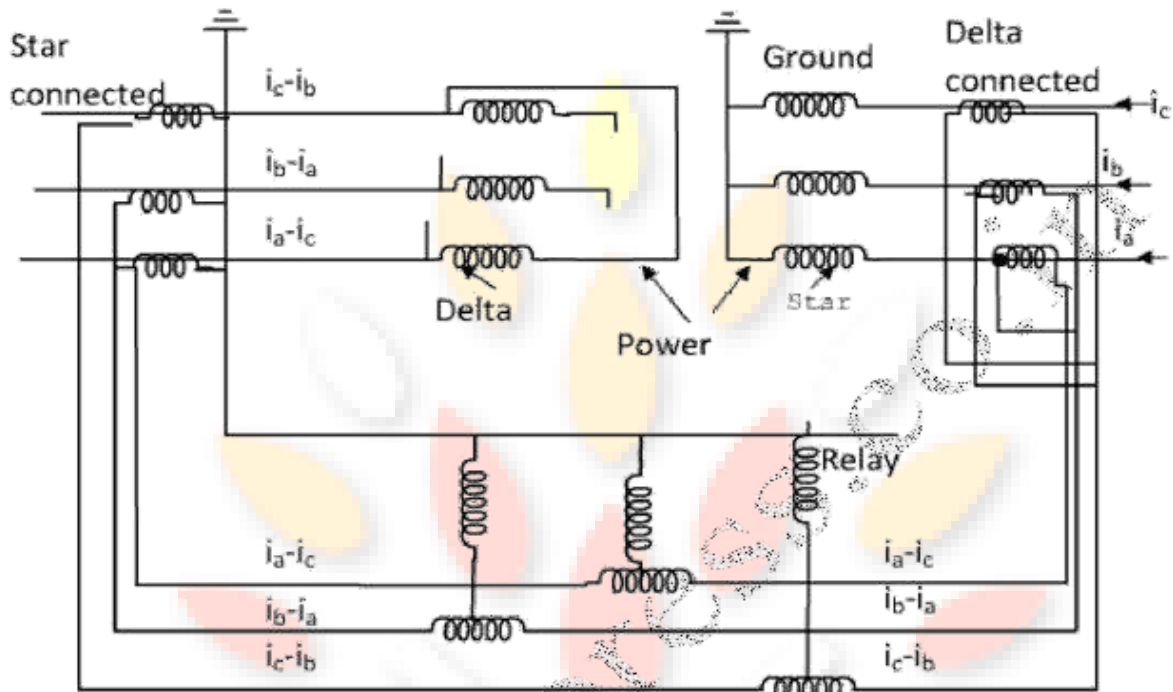

Fig: Differential protection of delta star

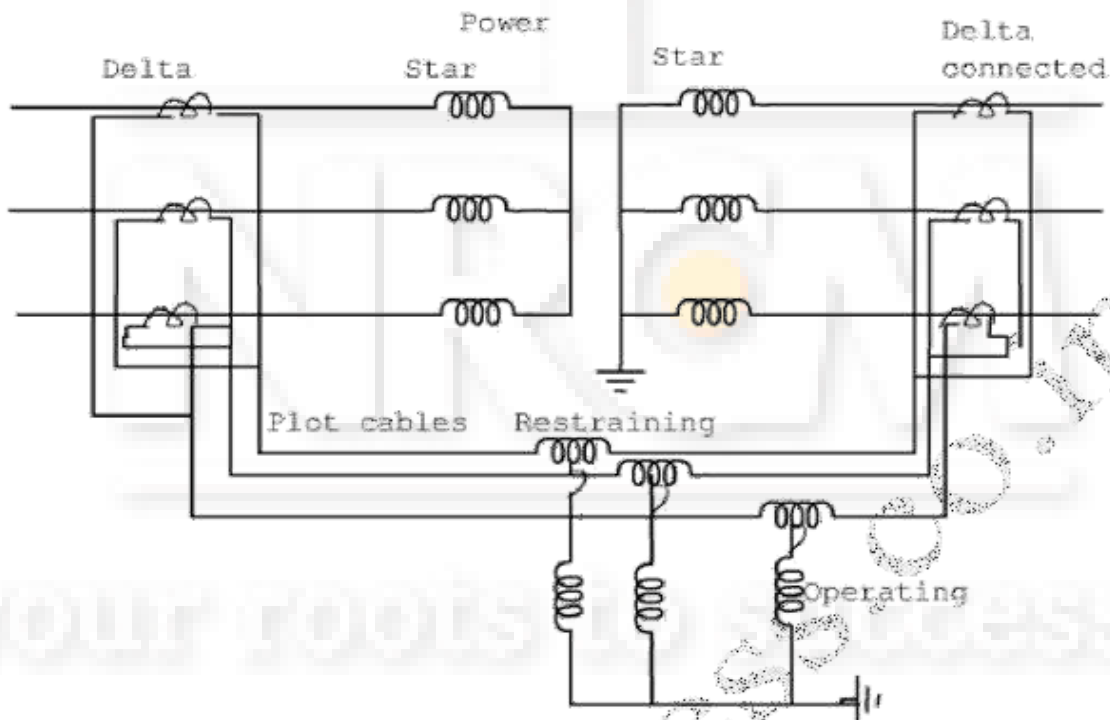
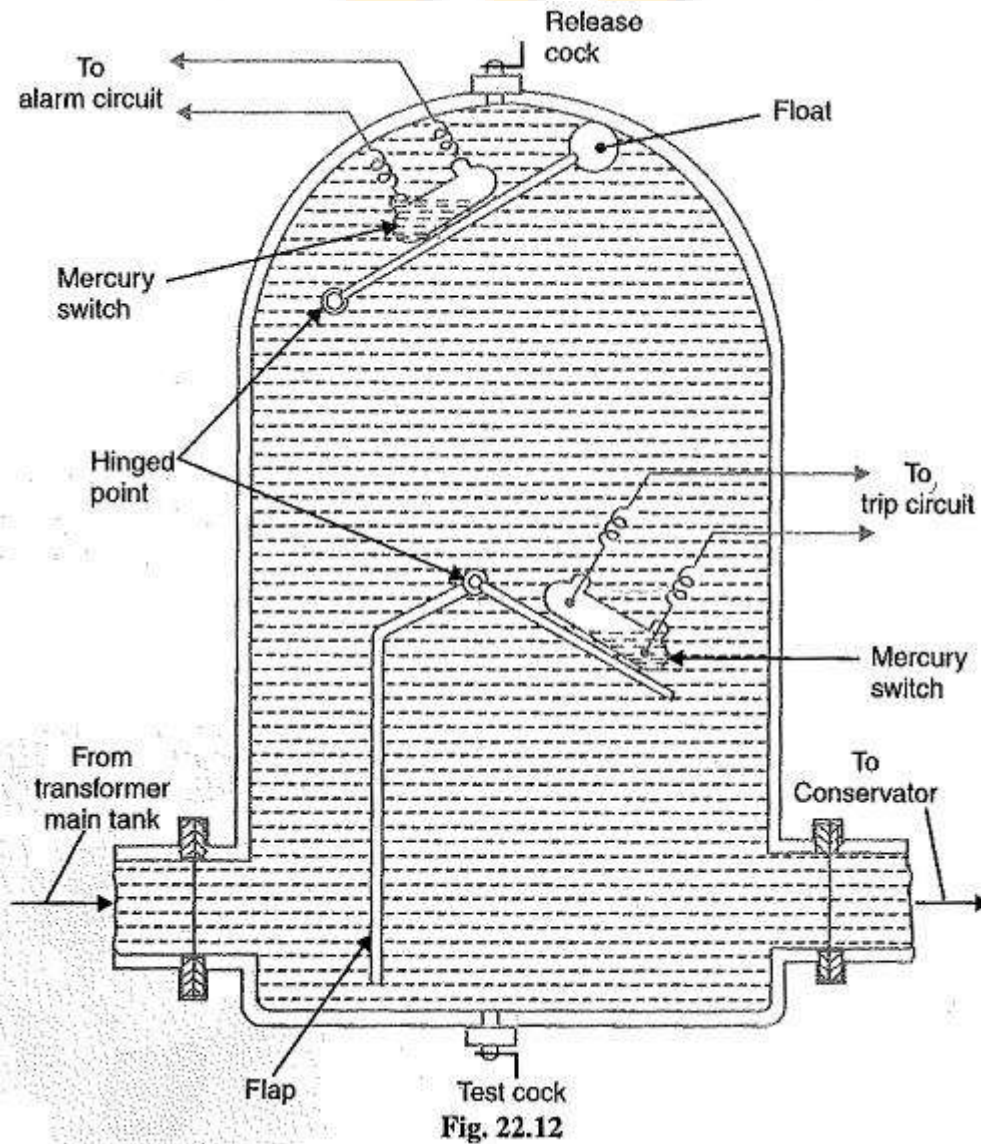

Fig: Differential protection of star-star

BUCHHOLZ RELAY:

Buchholz Relay is a gas-actuated relay installed in oil immersed transformers for protection against all kinds of faults. Named after its inventor, Buchholz, it is used to give an alarm in case of incipient (i.e. slow-developing) faults in the transformer and to disconnect the transformer from the supply in the event of severe internal faults. It is usually installed in the pipe connecting the conservator to the main tank as shown in Fig. 22.11. It is a universal practice to use Buchholz relays on all such oil immersed transformers having ratings in excess of 750 kVA.



Construction: Fig. 22.12 shows the constructional details of a Buchholz relay. It takes the form of a domed vessel placed in the connecting pipe between the main tank and the conservator. The device has two elements. The upper element consists of a mercury type switch attached to a float. The lower element contains a mercury switch mounted on a hinged type flap located in the direct path of the flow of oil from the transformer to the conservator. The upper element closes an alarm circuit during incipient faults whereas the lower element is arranged to trip the circuit breaker in case of severe internal faults.

OPERATION:

The operation of Buchholz relay is as follows

- (i) In case of incipient faults within the transformer, the heat due to fault causes the decomposition of some transformer oil in the main tank. The products of decomposition contain more than 70% of hydrogen gas. The hydrogen gas being light tries to go into the conservator and in the process gets entrapped in the upper part of relay [chamber](#). When a pre-determined amount of gas gets accumulated, it exerts sufficient pressure on the float to cause it to tilt and close the contacts of mercury switch attached to it. This completes the alarm circuit to sound an alarm.
- (ii) If a serious fault occurs in the transformer, an enormous amount of gas is generated in the main tank. The oil in the main tank rushes towards the conservator via the Buchholz relay and in doing so tilts the flap to close the contacts of mercury switch. This completes the trip circuit to open the circuit breaker controlling the transformer.

Advantages of Buchholz Relay:

- It is the simplest form of transformer protection.
- It detects the incipient faults at a stage much earlier than is possible with other forms of protection.

Disadvantages of Buchholz Relay:

- It can only be used with oil immersed transformers equipped with conservator tanks.
- The device can detect only faults below oil level in the transformer. Therefore, separate protection is needed for connecting cables.

PROTECTION OF BUS BARS

Protection is provided to isolate the faulty busbar. The busbar zone, for the purpose of protection, includes not only the busbars themselves but also the isolating switches, circuit breakers and the associated connections. In the event of fault on any section of the busbar, all the circuit equipments connected to that section must be tripped out to give complete isolation.

The standard of construction for busbars has been very high, with the result that bus faults are extremely rare. However, the possibility of damage and service interruption from even a rare bus fault is so great that more attention is now given to this form of protection. Improved relaying methods have been developed, reducing the possibility of incorrect operation. The two most commonly used schemes for busbar protection are:

- **Differential protection**
- **Fault bus protection**

DIFFERENTIAL PROTECTION:

The basic method for busbar protection is the differential scheme in which currents entering and leaving the bus are totalised. During normal load condition, the sum of these currents is equal to zero. When a fault occurs, the fault current upsets the balance and produces a differential current to operate a relay.

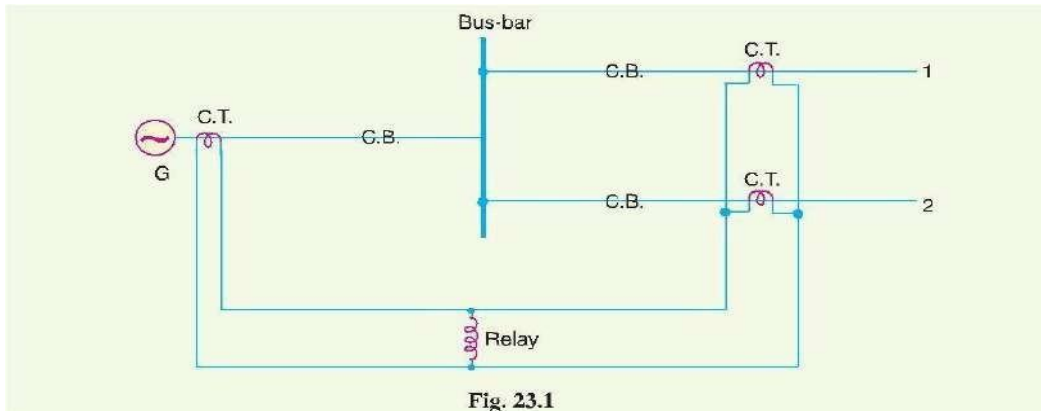

Fig. 23.1

Fig. 23.1 shows the single line diagram of current differential scheme for a station busbar. The busbar is fed by a generator and supplies load to two lines. The secondaries of current transformers in the generator lead, in line 1 and in line 2 are all connected in parallel. The protective relay is connected across this parallel connection.

All CTs must be of the same ratio in the scheme regardless of the capacities of the various circuits. Under normal load conditions or external fault conditions, the sum of the currents entering the bus is equal to those leaving it and no current flows through the relay. If a fault occurs within the protected zone, the currents entering the bus will no longer be equal to those leaving it. The difference of these currents will flow through the relay and cause the opening of the generator, circuit breaker and each of the line circuit breakers.

FAULT BUS PROTECTION:

It is possible to design a station so that the faults that develop are mostly earth-faults. This can be achieved by providing earthed metal barrier (known as fault bus) surrounding each conductor throughout its entire length in the bus structure. With this arrangement, every fault that might occur must involve a connection between a conductor and an earthed metal part. By directing the flow of earth-fault current, it is possible to detect the faults and determine their location. This type of protection is known as fault bus protection.

Fig. 23.2 shows the schematic arrangement of fault bus protection. The metal supporting structure or fault bus is earthed through a current transformer. A relay is connected across the

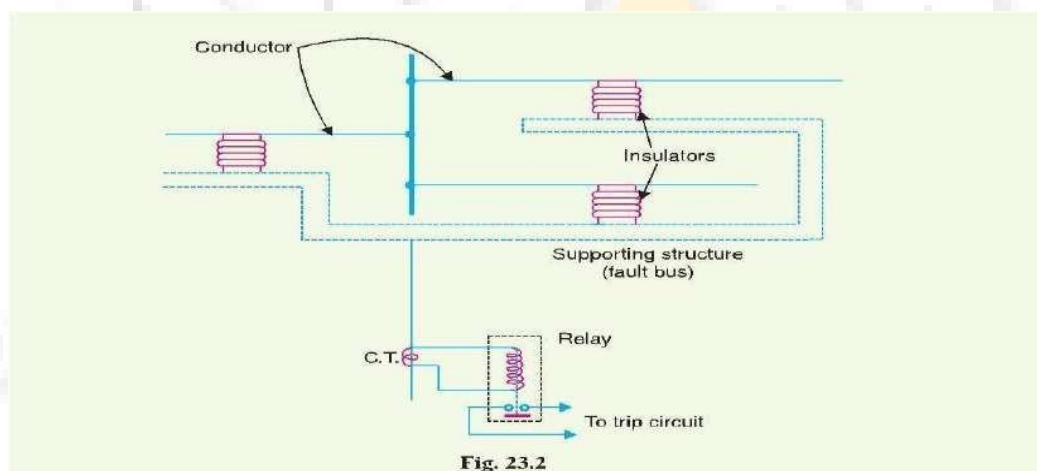

Fig. 23.2

secondary of this CT. Under normal operating conditions, there is no current flow from fault bus to ground and the relay remains inoperative. A fault involving a connection between a conductor and earthed supporting structure will result in current flow to ground through the fault bus, causing the relay to operate. The operation of relay will trip all breakers connecting equipment to the bus.

PROTECTION OF LINES

The probability of faults occurring on the lines is much more due to their greater length and exposure to atmospheric conditions. This has called for many protective schemes which have no application to the comparatively simple cases of alternators and transformers. The requirements of line protection are:

- (i) In the event of a short circuit, the circuit breaker closest to the fault should open, all other circuit breakers remaining in a closed position.
- (ii) In case the nearest breaker to the fault fails to open, back-up protection should be provided by the adjacent circuit breakers.
- (iii) The relay operating time should be just as short as possible in order to preserve system stability, without unnecessary tripping of circuits.

The protection of lines presents a problem quite different from the protection of station apparatus such as generators, transformers and busbars. While differential protection is ideal method for lines, it is much more expensive to use. The two ends of a line may be several kilometres apart and to compare the two currents, a costly pilot-wire circuit is required. This expense may be justified but in general less costly methods are used. The common methods of line protection are:

- (i) **Time-graded overcurrent protection**
- (ii) **Differential protection**
- (iii) **Distance protection**

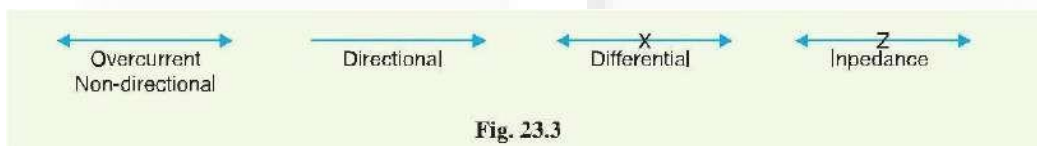

Fig. 23.3 shows the symbols indicating the various types of relay

TIME-GRADED OVERCURRENT PROTECTION

In this scheme of overcurrent protection, time discrimination is incorporated. In other words, the time setting of relays is so graded that in the event of fault, the smallest possible part of the system is isolated. We shall discuss a few important cases.

RADIAL FEEDER: The main characteristic of a radial system is that power can flow only in one direction, from generator or supply end to the load. It has the disadvantage that continuity of supply cannot be maintained at the receiving end in the event of fault. Time-graded protection of a radial feeder can be achieved by using

- (i) definite time relays and (ii) inverse time relays.

Using definite time relays. Fig. 23.4 shows the overcurrent protection of a radial feeder by definite

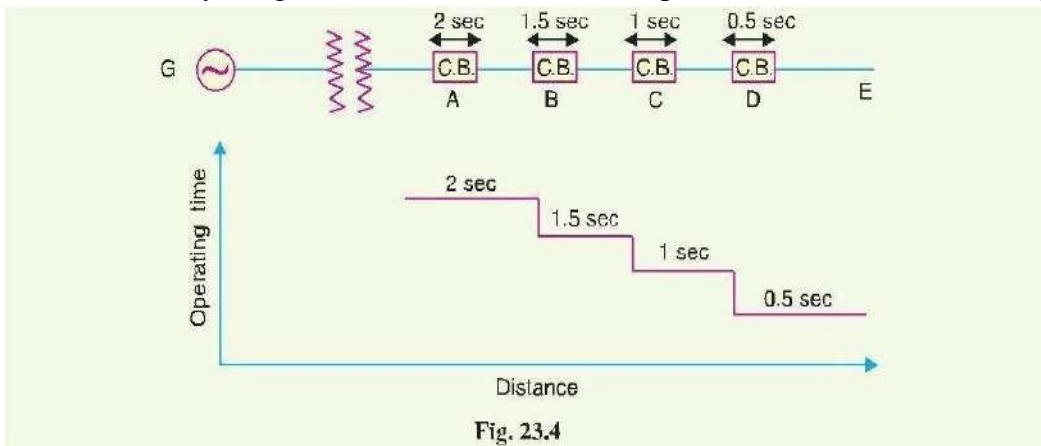

Fig. 23.4

time relays. The time of operation of each relay is fixed and is independent of the operating current. Thus relay D has an operating time of 0.5 second while for other relays, time delay* is successively increased by 0.5 second. If a fault occurs in the section DE, it will be cleared in 0.5 second by the relay and circuit breaker at D because all other relays have higher operating time. In this way only section DE of the system will be isolated. If the relay at D fails to trip, the relay at C will operate after a time delay of 0.5 second i.e. after 1 second from the occurrence of fault.

The disadvantage of this system is that if there are a number of feeders in series, the tripping time for faults near the supply end becomes high (2 seconds in this case). However, in most cases, it is necessary to limit the maximum tripping time to 2 seconds. This disadvantage can be overcome to a reasonable extent by using inverse-time relays.

(i) **Using inverse time relays.** Fig. 23.5 shows overcurrent protection of a radial feeder using

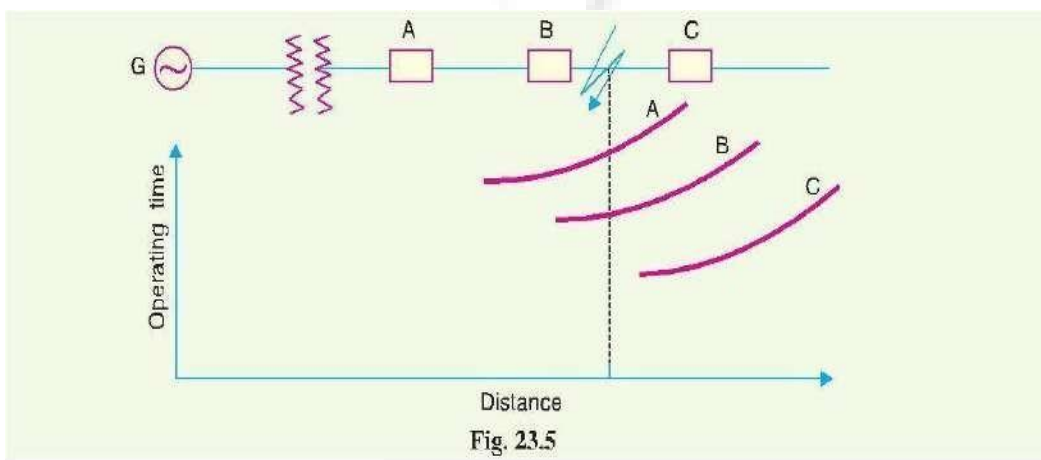

Fig. 23.5

inverse time relays in which operating time is inversely proportional to the operating current. With this arrangement, the farther the circuit breaker from the generating station, the shorter is its relay operating time. The three relays at *A*, *B* and *C* are assumed to have inverse-time characteristics. A fault in section *BC* will give relay times which will allow breaker at *B* to trip out before the breaker at *A*.



1. Parallel feeders. Where continuity of supply is particularly necessary, two parallel feeders may be installed. If a fault occurs on one feeder, it can be disconnected from the system and continuity of supply can be maintained from the other feeder. The parallel feeders cannot* be protected by non-directional overcurrent relays only. It is necessary to use directional relays also and to grade the time setting of relays for selective tripping's.

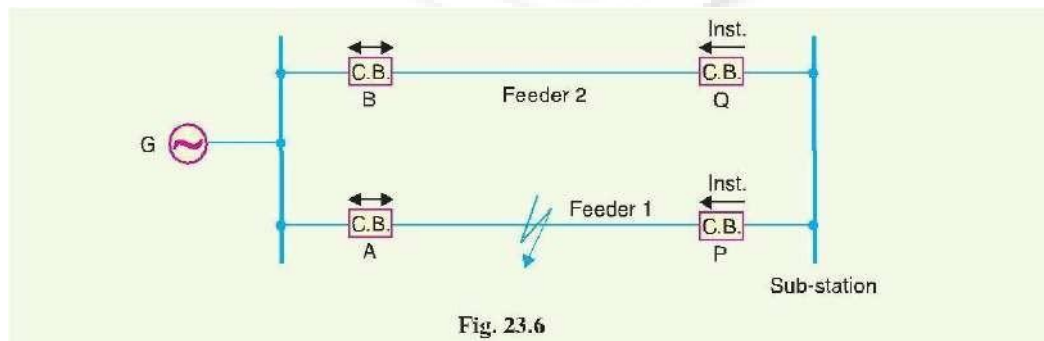

Fig. 23.6 shows the system where two feeders are connected in parallel between the generating station and the sub-station. The protection of this system requires that

- (i) Each feeder has a non-directional overcurrent relay at the generator end. These relays should have inverse-time characteristic.
- (ii) Each feeder has a reverse power or directional relay at the sub-station end. These relays should be instantaneous type and operate only when power flows in the reverse direction *i.e.* in the direction of arrow at *P* and *Q*.

Suppose an earth fault occurs on feeder 1 as shown in Fig. 23.6. It is desired that only circuit breakers at *A* and *P* should open to clear the fault whereas feeder 2 should remain intact to maintain the continuity of supply. In fact, the above arrangement accomplishes this job. The shown fault is fed via two routes, viz.

- Directly from feeder 1 via the relay A
- From feeder 2 via B, Q, sub-station and P

Therefore, power flow in relay Q will be in normal direction but is reversed in the relay P. This causes the opening of circuit breaker at P. Also the relay A will operate while relay B remains inoperative. It is because these relays have inverse-time characteristics and current flowing in relay A is in excess of that flowing in relay B. In this way only the faulty feeder is isolated.

2. Ring main system:

In this system, various power stations or sub-stations are interconnected by alternate routes, thus forming a closed ring. In case of damage to any section of the ring, that section may be disconnected for repairs, and power will be supplied from both ends of the ring, thereby maintaining continuity of supply.

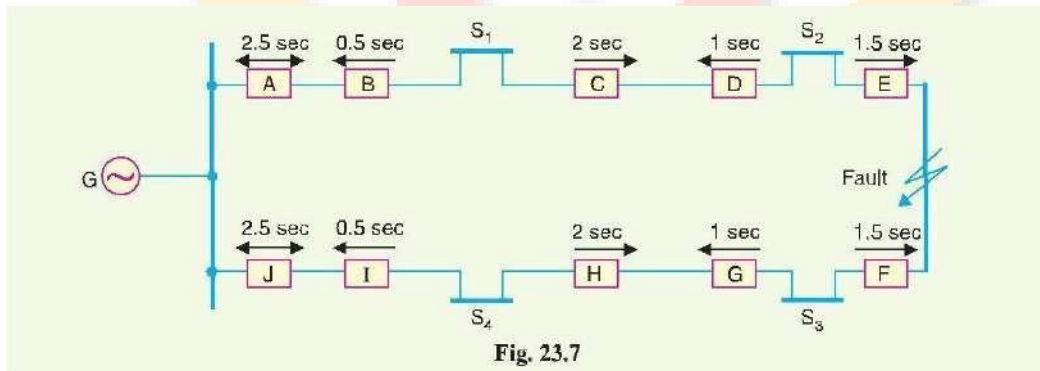

Fig. 23.7 shows the single line diagram of a typical ring main system consisting of one generator G supplying four sub-stations S1, S2, S3 and S4. In this arrangement, power can flow in both directions under fault conditions. Therefore, it is necessary to grade in both directions round the ring and also to use directional relays. In order that only faulty section of the ring is isolated under fault conditions, the types of relays and their time settings should be as follows:

- (i) The two lines leaving the generating station should be equipped with non-directional overcurrent relays (relays at A and J in this case).
- (ii) At each sub-station, reverse power or directional relays should be placed in both incoming and outgoing lines (relays at B, C, D, E, F, G, H and I in this case).
- (iii) There should be proper relative time-setting of the relays. As an example, going round the loop G S1 S2 S3 S4 G; the outgoing relays (viz at A, C, E, G and I) are set with decreasing time limits e.g.

$A = 2.5 \text{ sec}, C = 2 \text{ sec}, E = 1.5 \text{ sec}, G = 1 \text{ sec}$ and $I = 0.5 \text{ sec}$ similarly, going round the loop in the opposite direction (*i.e.* along G S4 S3 S2 S1 G), the *outgoing relays* (J, H, F, D and B) are also set with a decreasing time limit *e.g.*

$$J = 2.5 \text{ sec}, H = 2 \text{ sec}, F = 1.5 \text{ sec}, D = 1 \text{ sec}, B = 0.5 \text{ sec}.$$

Suppose a short circuit occurs at the point as shown in Fig. 23.7. In order to ensure

selectivity, it is desired that only circuit breakers at *E* and *F* should open to clear the fault whereas other sections of the ring should be intact to maintain continuity of supply.

In fact, the above arrangement accomplishes this job. The power will be fed to the fault *via* two routes *viz* (i) from *G* around *S1* and *S2* and (ii) from *G* around *S4* and *S3*. It is clear that relays at *A*, *B*, *C* and *D* as well as *J*, *I*, *H* and *G* will not trip. Therefore, only relays at *E* and *F* will operate before any other relay operates because of their lower time-setting

DIFFERENTIAL PILOT-WIRE PROTECTION

The differential pilot-wire protection is based on the principle that under normal conditions, the current entering one end of a line is equal to that leaving the other end. As soon as a fault occurs between the two ends, this condition no longer holds and the difference of incoming and outgoing currents is arranged to flow through a relay which operates the circuit breaker to isolate the faulty line. There are several differential protection schemes in use for the lines. However, only the following two schemes will be discussed:

- * **Merz-Price voltage balance system**
- * **Translay scheme**

1. MERZ-PRICE VOLTAGE BALANCE SYSTEM:

Fig. 23.8 shows the single line diagram of Merz-Price voltage balance system for the protection of a 3-phase line. Identical current transformers are placed in each phase at

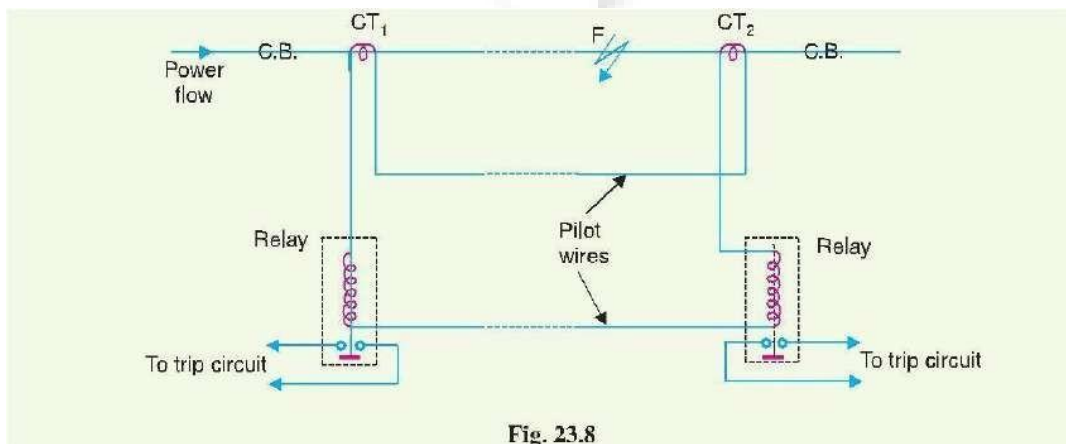

both ends of the line. The pair of CTs in each line is connected in series with a relay in such a way that under normal conditions, their secondary voltages are equal and in opposition *i.e.* they balance each other.

Under healthy conditions, current entering the line at one-end is equal to that leaving it at the other end. Therefore, equal and opposite voltages are induced in the secondaries of the CTs at the two ends of the line. The result is that no current flows through the relays. Suppose a fault occurs at point *F* on the line as shown in Fig. 23.8. This will cause a greater current to flow through CT1 than through CT2. Consequently, their secondary voltages become unequal and circulating current flows through the pilot wires and relays. The circuit breakers at both ends of the line will trip out and the faulty line will be isolated

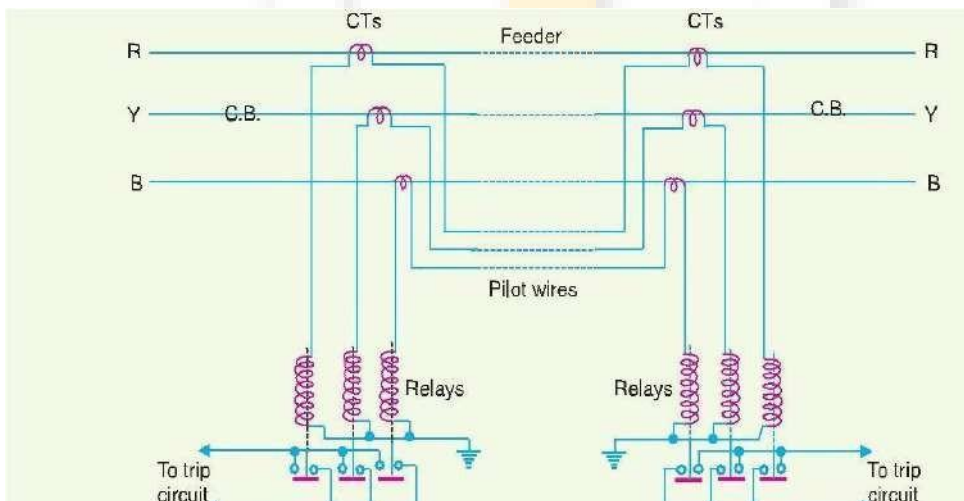

Fig. 23.9 shows the connections of Merz-Price voltage balance scheme for all the three phases of the line.

Advantages

- This system can be used for ring mains as well as parallel feeders.
- This system provides instantaneous protection for ground faults. This decreases the possibility of these faults involving other phases.
- This system provides instantaneous relaying which reduces the amount of damage to over-head conductors resulting from arcing faults.

Disadvantages

- Accurate matching of current transformers is very essential.
- If there is a break in the pilot-wire circuit, the system will not operate.
- This system is very expensive owing to the greater length of pilot wires required.
- In case of long lines, charging current due to pilot-wire capacitance* effects may be sufficient to cause relay operation even under normal conditions.
- This system cannot be used for line voltages beyond 33 kV because of constructional difficulties in matching the current transformers.

2. TRANSLAY SCHEME.

This system is similar to voltage balance system except that here balance or opposition is between the voltages induced in the secondary windings wound on the relay magnets and *not* between the secondary voltages of the line current transformers. This permits to use current transformers of normal design and eliminates one of the most serious limitations of original voltage balance system, namely; its limitation to the system operating at voltages not exceeding 33 kV.

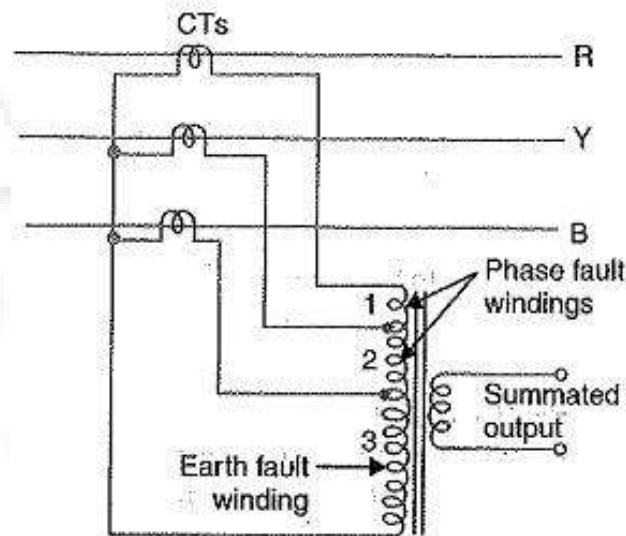

Fig. 23.10

The application of Translay scheme for a single phase line has already been discussed in Art. 21.20. This can be extended to 3-phase system by applying one relay at each end of each phase of the 3-phase line. However, it is possible to make further simplification by combining currents derived from all phases in a single relay at each end, using the principle of *summation transformer* (See Fig. 23.10). A summation transformer is a device that reproduces the polyphase line currents as a single-phase quantity. The three lines CTs are connected to the tapped primary of summation transformer. Each line CT energizes a different number of turns (from line to neutral) with a resulting single phase output. The use of summation transformer permits two advantages *viz* (i) primary windings 1 and 2 can be used for phase faults whereas winding 3 can be used for earth fault (ii) the number of pilot wires required is only two.

SCHEMATIC ARRANGEMENT:

The Translay scheme for the protection of a 3-phase line is shown in Fig. 23.11. The relays used in the scheme are essentially overcurrent induction type relays. Each relay has two electromagnetic elements. The upper element carries a winding (11 or 11 *a*) which is energised as a summation transformer from the secondaries of the line CTs connected in the phases of the line to be protected. The upper element also carries a secondary winding (12 or 12 *a*) which is connected in series with the operating winding (13 or 13 *a*) on the lower

magnet. The secondary windings 12, 12 *a* and operating windings 13, 13 *a* are connected in series in such a way that voltages induced in them oppose each other. Note that relay discs and tripping circuits have been omitted in the diagram for clarity.

This drawback is overcome in the **Beard-Hunter system**. In this system, each pilot-wire is surrounded by an insulated metallic sheath with a break half-way along its length. Half the pilot charging current thus comes from the sending end and half from the receiving end. Therefore, voltage applied to the relay at the sending end is balanced by an equal voltage at the receiving end.

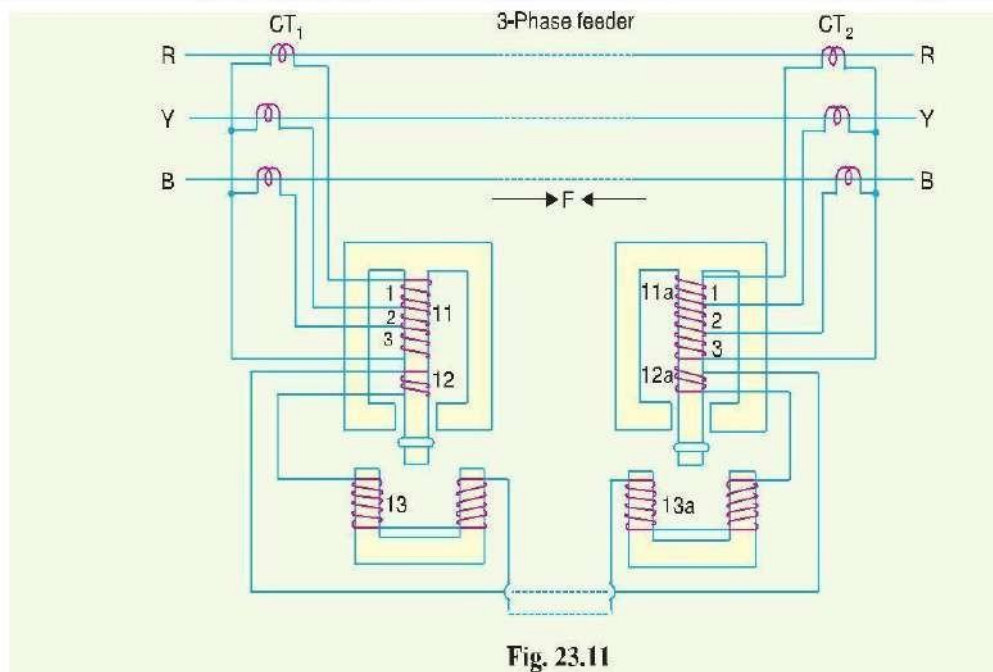

OPERATION:

When the feeder is sound, the currents at its two ends are equal so that the secondary currents in both sets of CTs are equal. Consequently, the currents flowing in the relay primary winding 11 and 11 *a* will be equal and they will induce equal voltages in the secondary windings 12 and 12 *a*. Since these windings are connected in opposition, no current flows in them or in the operating windings 13 and 13 *a*. In the event of a fault on the protected line, the line current at one end must carry a greater current than that at the other end. The result is that voltages induced in the secondary windings 12 and 12 *a* will be different and the current will flow through the operating coils 13, 13 *a* and the pilot circuit. Under these conditions, both upper and lower elements of each relay are energised and a forward torque acts on the each relay disc. The operation of the relays will open the circuit breakers at both ends of the line.

- ❖ Suppose a fault *F* occurs between phases *R* and *Y* and is fed from both sides as shown in Fig. 23.11. This will energise only section 1 of primary windings 11 and 11 *a* and

induce voltages in the secondary windings 12 and 12a. As these voltages are now additive*, therefore, current will circulate through operating coils 13, 13a and the pilot circuit. This will cause the relay contacts to close and open the circuit breakers at both ends. A fault between phases *Y* and *B* energises section 2 of primary windings 11 and 11a whereas that between *R* and *B* will energise the sections 1 and 2.

- ❖ Now imagine that an earth fault occurs on phase *R*. This will energise sections 1, 2 and 3 of the primary windings 11 and 11a. Again if fault is fed from both ends, the voltages induced in the secondary windings 12 and 12a are additive and cause a current to flow through the operating coils 13, 13a. The relays, therefore, operate to open the circuit breakers at both ends of the line. In the event of earth fault on phase *Y*, sections 2 and 3 of primary winding 11 and 11a will be energised and cause the relays to operate. An earth fault on phase *B* will energise only section 3 of relay primary windings 11 and 11a.

Advantages

- ❖ The system is economical as only two pilot wires are required for the protection of a 3-phase line.
- ❖ Current transformers of normal design can be used.
- ❖ Pilot wire capacitance currents do not affect the operation of relays.
- ❖ Because the fault is being fed from both sides.

DISTANCE PROTECTION

Both time-graded and pilot-wire systems are not suitable for the protection of very long high voltage transmission lines. The former gives an unduly long time delay in fault clearance at the generating station end when there are more than four or five sections and the pilot-wire system becomes too expensive owing to the greater length of pilot wires required. This has led to the development of distance protection in which the action of relay depends upon the distance (or impedance) between the point where the relay is installed and the point of fault. This system provides discrimination protection without employing pilot wires.

The principle and operation of distance relays have already been discussed in chapter 21. We shall now consider its application for the protection of transmission lines. Fig. 23.12 (i) shows a simple system consisting of lines in series such that power can flow only from left to right.

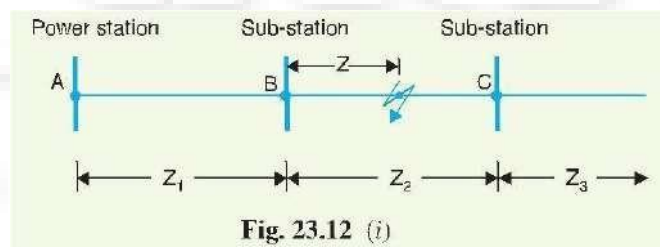

The relays at A, B and C are set to operate for impedance less than Z_1 , Z_2 and Z_3 respectively. Suppose a fault occurs between sub-stations B and C, the fault impedance at power station and sub-station A and B will be $Z_1 + Z$ and Z respectively. It is clear that for the

portion shown; only relay at B will operate. Similarly, if a fault occurs within section $A B$, then only relay at A will operate. In this manner, instantaneous protection can be obtained for all conditions of operation.

In actual practice, it is not possible to obtain instantaneous protection for complete length of the line due to inaccuracies in the relay elements and instrument transformers. Thus the relay at A [See Fig. 23.12 (i)] would not be very reliable in distinguishing between a fault at 99% of the distance $A B$ and the one at 101% of distance $A B$. This difficulty is overcome by using 'three-zone' distance protection shown in Fig. 23.12 (ii).

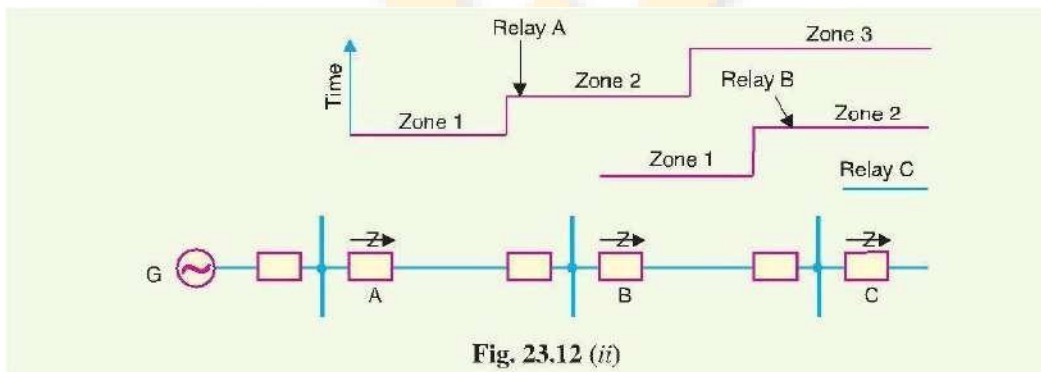

In this scheme of protection, three distance elements are used at each terminal. The zone 1 element covers first 90% of the line and is arranged to trip instantaneously for faults in this portion. The zone 2 element trips for faults in the remaining 10% of the line and for faults in the next line section, but a time delay is introduced to prevent the line from being tripped if the fault is in the next section. The zone 3 element provides back-up protection in the event a fault in the next section is not cleared by its breaker.

INTRODUCTION TO CARRIER-CURRENT PROTECTION:

In modern high-power electrical systems it is necessary to have quick-acting protections on long transmission lines. The requirements to be met by such protections are fully satisfied by the circulating current differential protection with its high sensitivity, quick action and independence upon the settings of the adjoining-section protections. Notwithstanding this, owing to the need for installing interconnecting conductors (cables), circulating current differential protections are confined to lines up to 8 or 15 km long.

It is, however, possible to make use of the main line conductors as the interconnecting conductors of a circulating current differential protection. The need for special interconnecting conductors (cables) then disappears and it hence becomes possible to set up a circulating current differential protection on transmission lines of any length. This is the basis of what are called carrier-current protections. The essential difference between carrier current protection and the voltage balance (Translay) pilot-wire protection is that, in the former, only the phase angles of the currents at the two ends of a line are compared instead of actual currents as in the latter case and this phase angle decides whether the fault is internal or external.

To make possible the transmission of commercial-frequency (50 Hz) load current, and at the same time use the main line conductors as the interconnecting conductors of the differential protection, it is necessary to use a current of higher frequency in order to be able to transmit current impulses from one end of the line to the other. High frequency signals in the range of 50 kHz to 400 kHz, commonly known as the carrier, are transmitted over the conductors of the protected line.

To inject the carrier signal and to restrict it within the protected section of the line suitable coupling apparatus and line traps are used at both ends of the protected section. This obviously makes this protection scheme quite expensive and justifies its application only in transmission lines of 110kV and above.

The main elements of the carrier channel are:

- (i) Transmitter
- (ii) Receiver
- (iii) Coupling equipment and
- (iv) Line trap.

Here we need not to go through the details of carrier current transmitters or receivers, all we need to know is that when a voltage of positive polarity is impressed on the control circuit of transmitter, it generates a high frequency output voltage. This output voltage is impressed between one phase conductor of the transmission line and the earth.

Each carrier-current receiver receives carrier current from its local transmitter as well as from the transmitter at the distant end of the line. In effect, the receiver converts the received carrier current into a dc voltage that can be used in a relay or other circuit to perform any desired function. The voltage is zero when carrier current is not being received.

Line trap unit is inserted between the bus-bar and connection of coupling capacitor to the line. It is a parallel LC network tuned to resonance at the high frequency. It hence presents high impedance to the high-frequency carrier current, but relatively low impedance (less than 0.1Ω) to the power-frequency (50 Hz) current. Traps are employed to confine the carrier currents to the protected section so as to avoid interference with or from other adjacent carrier current channels, and also to avoid loss of the carrier current signal in adjoining power circuits for any reason whatsoever, external short circuit being a principal reason. Consequently, carrier current can flow only along the line section between the traps.

The coupling capacitor (CC) connects the high frequency (carrier) equipment to one of the line conductors and simultaneously serves to isolate the carrier equipment from the high power-line voltage. It presents a relatively low reactance to the high frequency currents (about 150Ω at 500 kHz) and a high reactance to the power frequency (about $1.5 \text{ M} \Omega$ at 50 Hz). To reduce impedance further a low inductance is connected in series with the coupling capacitors to provide a resonance at carrier frequency.

It is thus evident that the commercial-frequency current will be able to flow only through the line conductors, while the high-frequency carrier current will circulate, when the receiver-transmitter operate, over the line conductor fitted with the high-frequency traps, through the coupling capacitors and through ground (the return conductor).

Methods of Carrier-Current Protection:

There are different methods of carrier current protection and basic forms of carrier protection are:

- (i) Directional Comparison Protection and
- (ii) Phase-Comparison Carrier Protection.
- (i) Directional Comparison Protection:

The protection operates on the basis of comparison of the fault-power flow directions at the two ends of the protected line. Operation takes place only when the flow of power at both ends of the line is in the bus-to-line direction, a condition which will evidently only arise in event of a fault on the protected section of the line. With directional-comparison relaying, the carrier pilot informs the equipment at one end of the line how a directional relay at the other end responds to a short circuit.

The conditions for internal and external faults are illustrated in Fig. 5.17. The relays at both ends of the protected section respond to fault power flowing away from the bus (tripping direction). For faults in the protected section, power flows in the tripping direction at both ends. For external faults power flow will be in opposite directions. A simple signal through carrier pilot is transmitted from one end to the other during faults.

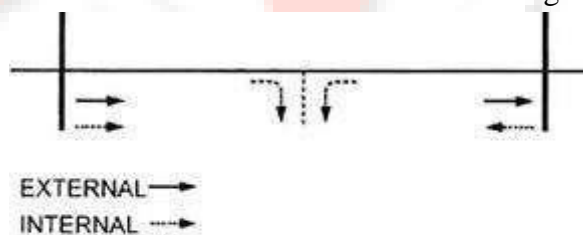

Fig. 5.17. Direction of Current Flow For External and Internal Faults

The pilot scheme can be employed for transmitting either blocking, or permitting signals. Thus possible carrier protections are of two types viz., carrier-blocking scheme and carrier-permitting scheme.

In a carrier-blocking protection scheme, the presence of carrier prevents or blocks operation of the protection. Carrier is, therefore, transmitted only upon the occurrence of a fault and is employed to prevent tripping in the event of an external fault. In carrier-permitting scheme the presence of carrier permits operation of the protection. The carrier blocking scheme is more reliable than carrier-permitting scheme. This is because a failure in the carrier-permitting signal equipment will mean a failure in isolating the fault, whereas a failure in carrier-blocking signal equipment isolates the section on which no fault exists. However, such false operation is preferable to the failure to clear a faulted section.

In a carrier-permitting protection scheme, normally no pilot signal is transmitted from any terminal. Should a short circuit occur in an immediately adjacent line section, a pilot signal is transmitted from any terminal where short-circuit current flows out of the line (i.e., in the non-tripping direction). While any station is transmitting a pilot signal, tripping is

blocked at all other stations. But should a short circuit occur on the protected section of the line, no pilot signal is transmitted and tripping occurs at any terminal where short-circuit current flows. Therefore, the pilot is blocking pilot, since the reception of a pilot signal is not required of permit tripping.

Directional comparison protection scheme (carrier blocking type) is illustrated in Fig. 5.18. The operation of the directional element provided on each breaker is indicated by the arrow and the non-operation by the letter O. Occurrence of fault activates relays on each of the breakers near the fault. This relay unless blocked from operation, causes tripping of breakers. The blocking signal is controlled by the directional relays on each breaker, and is transmitted from one end of a protected section to the other by carrier.

If a directional element determines that the fault is external to the protected section, a signal is transmitted blocking the operation of breakers at both ends of the section. In case the directional elements at both ends determine that fault is in the protected section, no blocking signal is transmitted from either end, and both breakers trip. The sequence of event for a fault at F is made clear by illustration in Fig. 5.18.

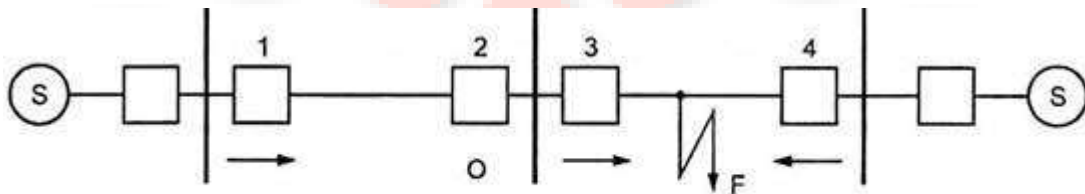

Fig. 5.18. Illustration of Directional Comparison Protection of a Power System

At breaker 1 the directional element shows that the fault may be in the section 1-2. This breaker trips if no blocking signal is received. No blocking signal is transmitted to breaker 2. At breaker 2 the directional element shows that the fault is not in section 1-2. A carrier signal is transmitted that blocks tripping of both the breakers 1 and 2.

At breakers 3 and 4 the directional elements show that the fault may be in section 3-4. No blocking signal is transmitted and after a very short time delay (1 to 3 cycles), both the breakers 3 and 4 trip.

(ii) Phase-Comparison Carrier Protection:

Phase-comparison relaying equipment uses its pilot to compare the phase relation between current entering in the protected zone and the current leaving the protected zone. The current magnitudes are not compared. Phase comparison protection provides only main or primary protection, backup protection must be provided in addition.

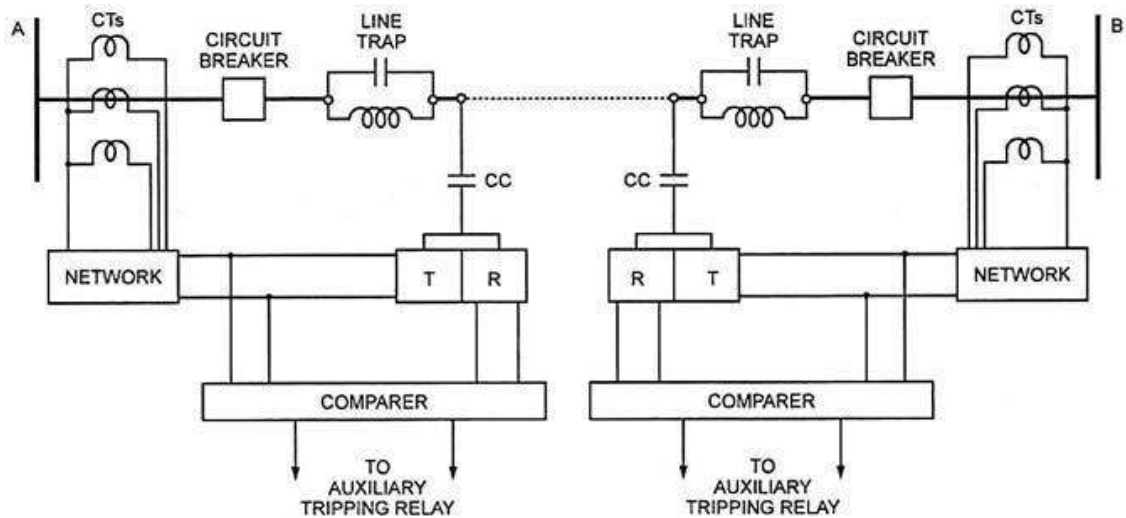

Fig. 5.19. Schematic Representation of Phase-Comparison Carrier Protection.

Figure 5.19 shows schematically the principal elements of the equipment provided at both ends of a two-terminal transmission line, employing a carrier-current pilot. As in wire-pilot protection, the transmission-line CTs feed a network that transforms the CT output currents into a single-phase sinusoidal output voltage. This voltage is applied to a carrier-current transmitter and to a ‘comparer’.

The output of a carrier-current receiver is also applied to the comparer. The comparer controls the operation of an auxiliary relay for tripping the transmission-line circuit breaker. These elements provide means for transmitting and receiving carrier-current signals for comparing at each end of the relative phase relations of the transmission-line current at both ends of the line

For examining the relations between the network output voltages at both ends of the line and also the carrier-current signals that are transmitted during external and internal fault conditions refer to Fig. 5.20. For an external fault at point D in Fig. 5.20, the network output voltages at stations A and B (waves a and c) are 180° out of phase.

This is because the connections of CTs at the two stations are reversed. Since an ac voltage is used to control the transmitter, carrier-current is transmitted only during the half cycles of the voltage wave when the polarity is positive. The carrier-current signals transmitted from stations A and B (waves b and d) are displaced in time, so that there is always a carrier-current signal being sent from one end or the other.

For internal fault at point C, the network output voltage at station B reverses because of reversal of power-line currents at station B, the carrier-current signals (waves b and d) are concurrent, and there is no signal from either station every other half cycle.

Phase-comparison relaying acts to block tripping at both terminals whenever the carrier-current signals are displaced in time so that there is little or no time interval when a signal is not being transmitted from one end or the other. When the carrier-current signals are approximately concurrent, tripping will occur whenever there is sufficient short-circuit current flowing. This is shown in Fig. 5.21 where network output voltages are superimposed, and the related tripping and blocking tendencies are illustrated.

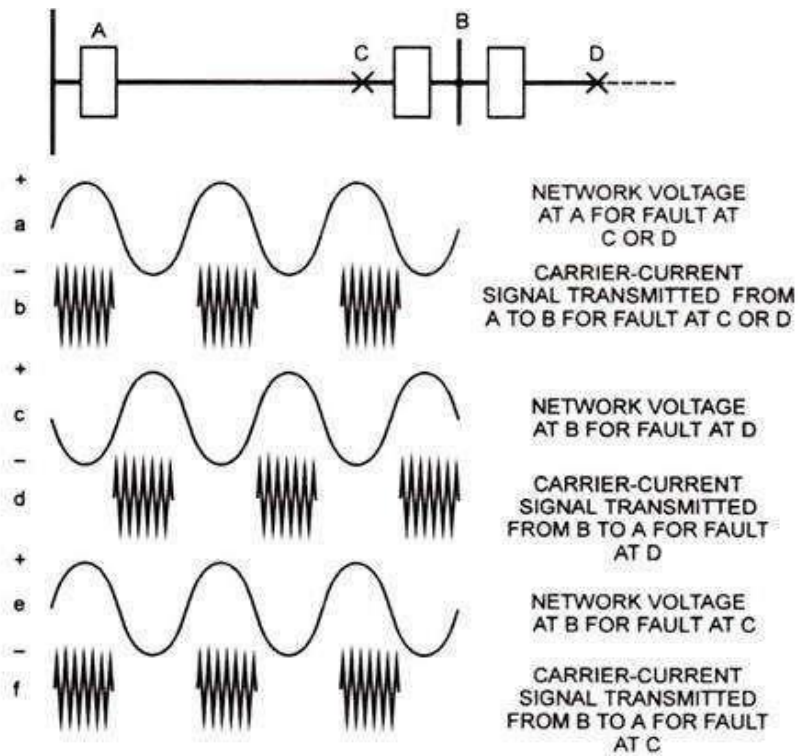

Fig. 5.20. Relations Between Network Output Voltages and Carrier-Current Signals

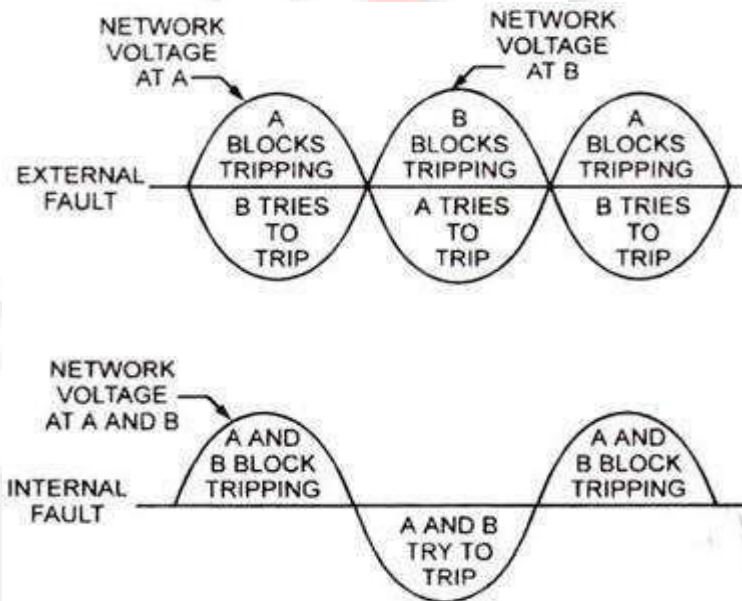

Fig. 5.21. Relation of Tripping and Blocking Tendencies To Network Output Voltages

As shown in Figs. 5.20 and 5.21, the equipment at one station transmits a blocking carrier-current signal during one half cycle, and then stops transmitting and tries to trip during the next half cycle, if carrier current is not received from the other end of the line during this half cycle, the equipment operates to trip its breaker. But, if carrier current is received from the other end of the line during the interval when the local carrier-current transmitter is idle tripping does not occur.

Advantages of Carrier-Current Protection:

Carrier current over the power line provides simultaneous tripping of circuit breakers at both ends of the line in one to three cycles. Thereby high speed fault clearing is obtained, which improves the power system stability. Besides, there are several other advantages of carrier-current protection.

These are:

1. Fast, simultaneous operation of circuit breakers at both ends.
2. Auto-reclosing simultaneous reclosing signal is sent thereby simultaneous (1 to 3 cycles) reclosing of circuit breaker is obtained.
3. Fast clearing prevents shocks to systems.
4. Tripping due to synchronising power surges does not occur, yet during internal fault clearing is obtained.
5. For simultaneous faults, carrier-current protection provides easy discrimination.
6. Carrier-current relaying is best suited for fast relaying in conjunction with modern fast circuit breakers.
7. No separate wires are required for signalling, as the power lines themselves carry power as well as communication signalling. Hence the capital and operating costs are smaller.

The main application of power line carrier has been for the purpose of supervisory control, telephone communication, telemetering and relaying.

BUS-BAR PROTECTION

When the fault occurs on the bus bars whole of the supply is interrupted, and all the healthy feeders are disconnected. The majority of the faults is single phase in nature, and these faults are temporary. The bus zone fault occurs because of various reasons like failure of support insulators, failure of circuit breakers, foreign object accidentally falling across the bus bar, etc., for removing the bus fault, all the circuits connecting to the faulty section need to be open.

The most commonly used schemes for bus zone protection are:

- Backup protection
- Differential Overcurrent Protection
 - Circulating current protection
 - Voltage Overvoltage Protection
- Frame leakage protection.

BACKUP PROTECTION FOR BUS-BARS

This is the simple way of protecting the bus-bar from the fault. The fault occurs on the bus-bar because of the supplying system. So the backup protection is provided to the supply system. The figure below shows the simple arrangement for the protection of bus-bar.

The bus A is protected by the distance protection of the bus B. If the fault occurs on A, then

the B will operate. The operating times of the relay will be 0.4 seconds.

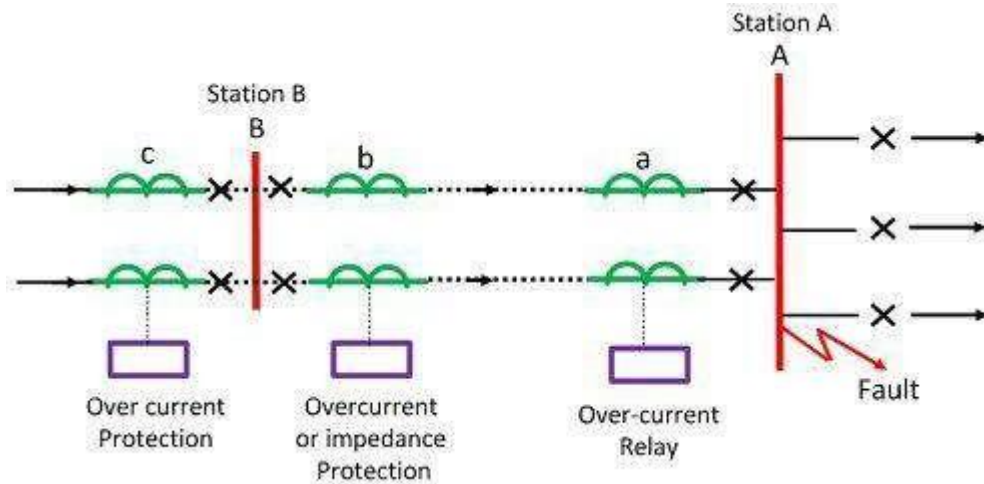

The bus-bar protection system has few disadvantages like the protection system is slow. Such system is mainly used for the protection of the transmission lines. But as the protection system is very economical, thereby it is also used for the bus-bar protection.

This protective scheme is not used for small switchgear system. The backup protection system has many disadvantages like delayed in action, disconnections of more circuits for two or more transmission line requires etc.

FRAMELEAKAGE OR FAULT-BUS PROTECTION

This method insulates the bus-supporting structure and its switchgear from the ground, interconnecting all the framework, circuit breakers tanks, etc. and provided a single ground tank connection through a CT that feeds an overcurrent relay. The overcurrent relay controls a multi-contact auxiliary relay that trips the breakers of all circuits connected to the bus.

In such type of protection, the only metal supporting structure or fault-bus is grounded through a CT, secondary of which is connected to an overcurrent relay. Under normal operating condition, the relay remains inoperative, but fault involving a connection between a conductor and the ground supporting structure will result in current flow to ground through the fault bus, causing the relay to operate. The operation of the relay will trip all the breakers connecting equipment to the bus.

DIFFERENTIAL OVER CURRENT PROTECTION

Current Differential Protection

The current differential protection scheme works on the principle of the circulating current which states that the current enters into the bus-bar is equal to the current leaving the bus-bar. The sum of the incoming and outgoing junction is equal to zero. If the sum of current is not equal to zero, then the fault occurs in the system. The differential protection scheme is used both for the protection of the phase-to-phase fault and for the ground fault. Schematic diagram of bus differential protection relay is shown in the figure below. The current transformers are placed on both the incoming and the outgoing end of the bus-bar. The secondary terminals of the current transformer are parallel connected to each other.

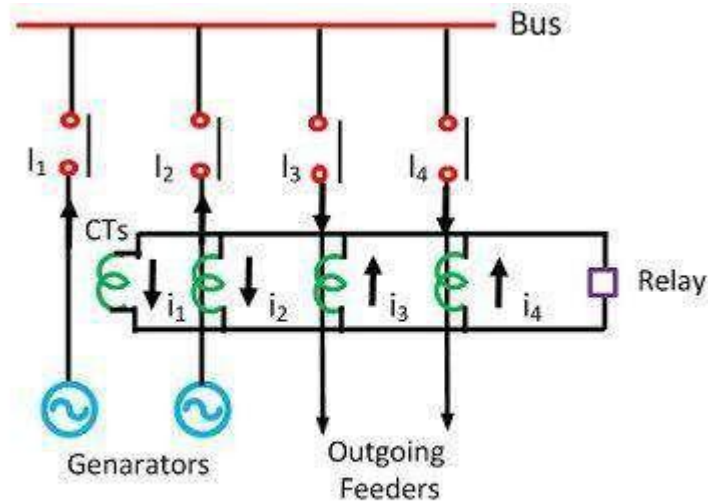

Schematic Diagram of Bus Differential Protection

Circuit Globe

summation current of the current transformer flows through the operating coil of the relay. The current flows through the relay coils indicates the short circuit current present on the secondary of the CTs. Thus, the relay sends the signal to the circuit breakers to open the contacts.

The drawback of such types of the scheme is that the iron cored current transformer causes the fault operation of the relay at the time of the external fault.

VOLTAGE DIFFERENTIAL PROTECTION RELAY

In this scheme, the coreless CTs are used. The linear couplers are used for increases the number of turns on the secondary sides of the CTs. The secondary relays connected in series with the help of the pilot wires. The relay coil is also connected in series with the second terminal.

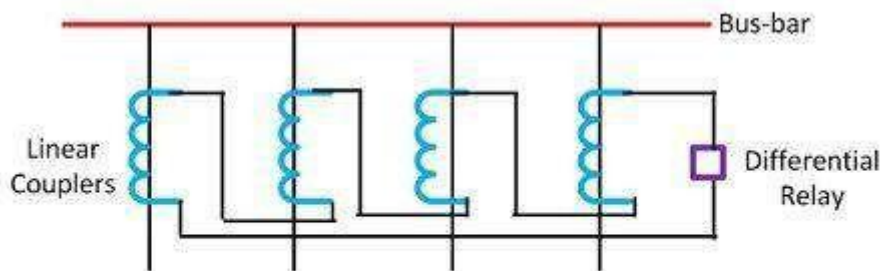

Voltage Differential Relaying For Bus-bar

Circuit Globe

When the system is free from fault or external fault occurs on the system, the sum of secondary current of CTs becomes zero. On the occurrence of the internal fault, the fault current flows the differential relay. The relay becomes operative and gives command to the circuit breaker to open their contacts. Thus, protects the system from damage.

UNIT- IV NEUTRAL GROUNDING

Neutral Grounding

In power system, *grounding or earthing means connecting frame of electrical equipment (non-current carrying part) or some electrical part of the system (e.g. neutral point in a star-connected system, one conductor of the secondary of a transformer etc.) to earth i.e. soil. This connection to earth may be through a conductor or some other circuit element (e.g. a resistor, a circuit breaker etc.) depending up on the situation. Regardless of the method of connection to earth, grounding or earthing offers two principal advantages. First, it provides protection to the power system. For example, if the neutral point of a star-connected system is grounded through a circuit breaker and phase to earth fault occurs on any one line, a large fault current will flow through the circuit breaker. The circuit breaker will open to isolate the faulty line. This protects the power system from the harmful effects of the fault. Secondly, earthing of electrical equipment (e.g. domestic appliances, hand-held tools, industrial motors etc.) ensures the safety of the persons handling the equipment. For example, if insulation fails, there will be a direct contact of the live conductor with the metallic part (i.e.frame) of the equipment. Any person in contact with the metallic part of this equipment will be subjected to a dangerous electrical shock which can be fatal. In this chapter, we shall discuss the importance of grounding or earthing in the line of power system with special emphasis on neutral grounding.

Grounding or Earthing:

The process of connecting the metallic frame (i.e. non-current carrying part) of electrical equipment or some electrical part of the system (e.g. neutral point in a star-connected system, one conductor of the secondary of a transformer etc.) to earth (i.e. soil) is called grounding or earthing. It is strange but true that grounding of electrical systems is less understood aspect of power system. Nevertheless, it is a very important subject. If grounding is done systematically in the line of the power system, we can effectively prevent accidents and damage to the equipment of the power system and at the same time continuity of supply can be maintained.

Grounding or earthing may be classified as:

- ❖ Equipment grounding
- ❖ System grounding.

Equipment grounding deals with earthing the non-current-carrying metal parts of the electrical equipment. On the other hand, system grounding means earthing some part of the electrical system e.g. earthing of neutral point of star-connected system in generating stations and sub-stations. Equipment Grounding the process of connecting non-current-carrying meta

parts (i.e. metallic enclosure) of the electrical equipment to earth (i.e. soil) in such a way that in case of insulation failure, the enclosure effectively remains at earth potential is called equipment grounding.

We are frequently in touch with electrical equipment of all kinds, ranging from domestic appliances and hand-held tools to industrial motors. We shall illustrate the need of effective equipment grounding by considering a single-phase circuit composed of a 230 V source connected to a motor M as shown in Fig. 26.1. Note that neutral is solidly grounded at the service entrance. In the interest of easy understanding, we shall divide the discussion into three heads viz.

1. Ungrounded enclosure
2. Enclosure connected to neutral wire
3. Ground wire connected to enclosure.

Ungrounded enclosure:

Fig. 26.1 shows the case of ungrounded metal enclosure. If a person touches the metal enclosure, nothing will happen if the equipment is functioning correctly. But if the winding insulation becomes faulty, the resistance R_e between the motor and enclosure drops to a low value (a few hundred ohms or less). A person having a body resistance R_b would complete the current path as shown in Fig. 26.1.

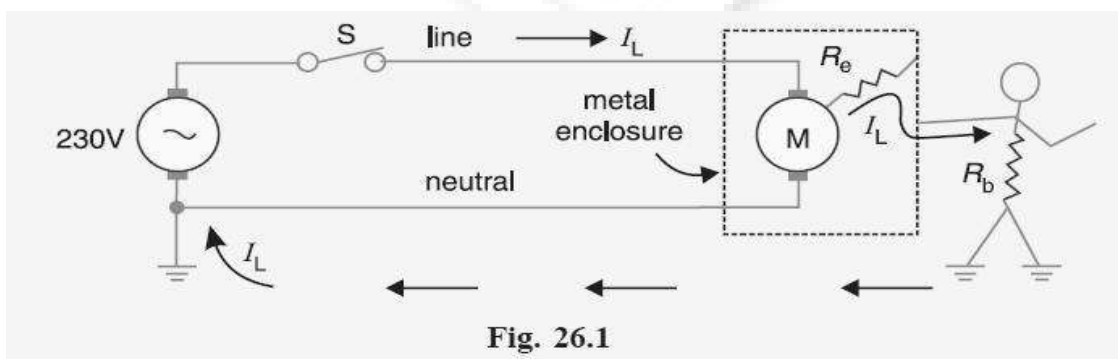
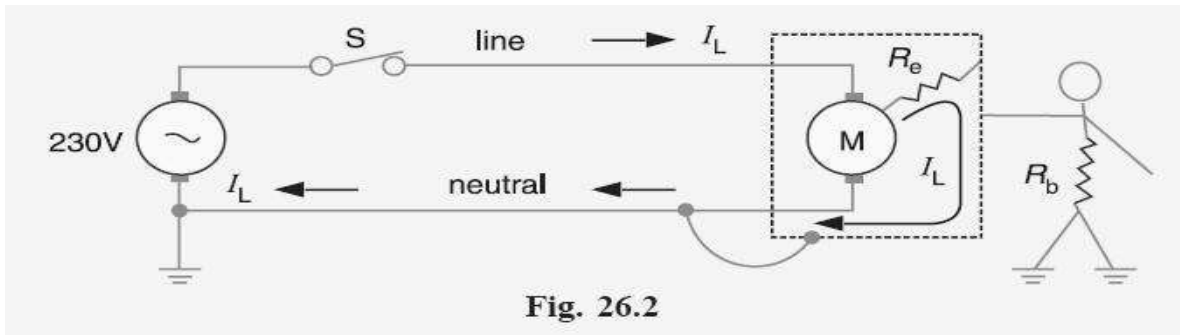

Fig. 26.1

If R_e is small (as is usually the case when insulation failure of winding occurs), the leakage current I_L through the person's body could be dangerously high. As a result, the person would get severe electric shock which may be fatal. Therefore, this system is unsafe.

- (i) Enclosure connected to neutral wire. It may appear that the above problem can be solved by connecting the enclosure to the grounded neutral wire as shown in Fig. 26.2. Now the leakage current I_L flows from the motor, through the enclosure and straight back to the neutral wire (See Fig. 26.2). Therefore, the enclosure remains at earth potential. Consequently, the operator would not experience any electric shock.



(ii) The trouble with this method is that the neutral wire may become open either accidentally or due to a faulty installation. For example, if the switch is inadvertently in series with the neutral rather than the live wire (See Fig. 26.3), the motor can still be turned on and off. However, if some- one touched the enclosure while the motor is off, he would receive a severe electric shock (See Fig. 26.3). It is because when the motor is off, the potential of the enclosure rises to that of the live conductor.

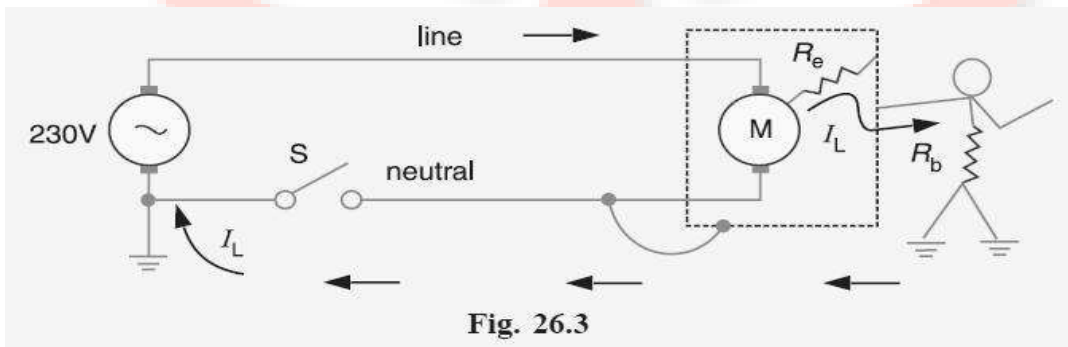

(ii) Ground wire connected to enclosure. To get rid of this problem, we install a third wire, called ground wire, between the enclosure and the system ground as shown in Fig. 26.4. The ground wire may be bare or insulated. If it is insulated, it is coloured green.

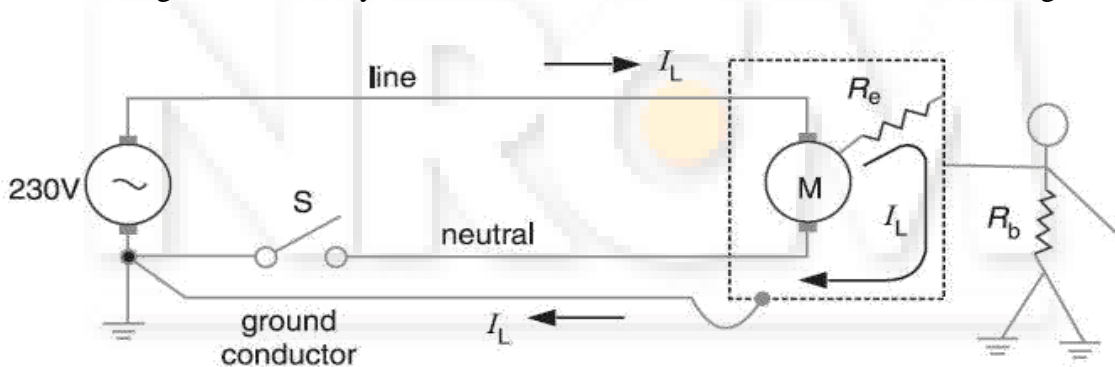

Electrical outlets have three contacts — one for live wire, one for neutral wire and one for ground wire.

SYSTEM GROUNDING:

The process of connecting some electrical part of the power system (e.g. neutral point of a star-connected system, one conductor of the secondary of a transformer etc.) to earth (i.e. soil) is called system grounding.

The system grounding has assumed considerable importance in the fast expanding power system. By adopting proper schemes of system grounding, we can achieve many advantages including protection, reliability and safety to the power system network. But before discussing the various aspects of neutral grounding, it is desirable to give two examples to appreciate the need of system grounding.

Fig. 26.5 (i) shows the primary winding of a distribution transformer connected between the line and neutral of a 11 kV line. If the secondary conductors are ungrounded, it would appear that a person could touch either secondary conductor without harm because there is no ground return. However, this is not true. Referring to Fig. 26.5, there is capacitance C_1 between primary and secondary and capacitance C_2 between secondary and ground. This capacitance coupling can produce a high voltage between the secondary lines and the ground. Depending upon the relative magnitudes of C_1 and C_2 , it may be as high as 20% to 40% of the primary voltage. If a person touches either one of the secondary wires, the resulting capacitive current I_C flowing through the body could be dangerous even in case of small transformers [See Fig. 26.5(ii)]. For example, if I_C is only 20 mA, the person may get a fatal electric shock.

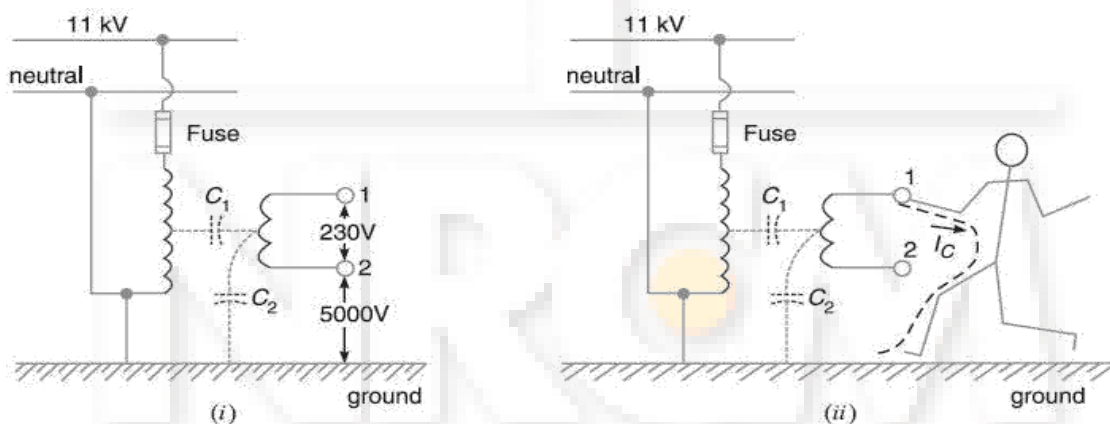

Fig. 26.5

If one of the secondary conductors is grounded, the capacitive coupling almost reduces to zero and so is the capacitive current I_C . As a result, the person will experience no electric shock. This explains the importance of system grounding.

(ii) Let us now turn to a more serious situation. Fig. 26.6 (i) shows the primary winding of a distribution transformer connected between the line and neutral of a 11 kV line. The secondary conductors are ungrounded. Suppose that the high voltage line (11 kV in this case) touches the 230 V conductor as shown in Fig. 26.6 (i). This could be caused by an

internal fault in the transformer or by a branch or tree falling across the 11 kV and 230 V lines. Under these circumstances, a very high voltage is imposed between the secondary conductors and ground. This would immediately puncture the 230 V insulation, causing a massive flashover. This flashover could occur anywhere on the secondary network, possibly inside a home or factory. Therefore, ungrounded secondary in this case is a potential fire hazard and may produce grave accidents under abnormal conditions.

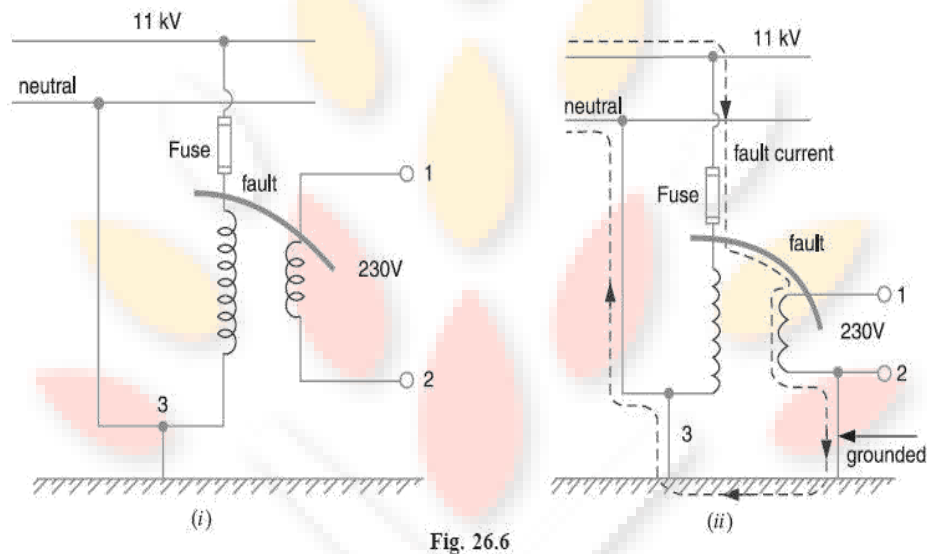

Fig. 26.6

If one of the secondary lines is grounded as shown in Fig. 26.6(ii), the accidental contact between a 11 kV conductor and a 230 V conductor produces a dead short. The short-circuit current (i.e. fault current) follows the dotted path shown in Fig. 26.6 (ii). This large current will blow the fuse on the 11 kV side, thus disconnecting the transformer and secondary distribution system from the 11 kV line. This explains the importance of system grounding in the line of the power system.

UNGROUNDING NEUTRAL SYSTEM:

In an ungrounded neutral system, the neutral is not connected to the ground i.e. the neutral is isolated from the ground. Therefore, this system is also called isolated neutral system or free neutral system. Fig. 26.7 shows ungrounded neutral system. The line conductors have capacitances between one another and to ground. The former are delta-connected while the latter are star-connected. The delta-connected capacitances have little effect on the grounding characteristics of the system (i.e. these capacitances do not effect the earth circuit) and, therefore, can be neglected. The circuit then reduces to the one shown in Fig. 26.8(i).

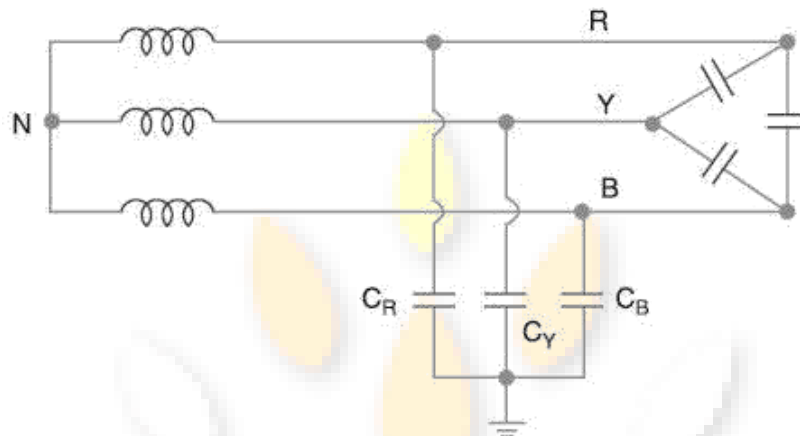

Fig. 26.7

Circuit behavior under normal conditions:

Let us discuss the behavior of ungrounded neutral system under normal conditions (i.e. under steady state and balanced conditions). The line is assumed to be perfectly transposed so that each conductor has the same capacitance to ground.

Therefore, $C_R = C_Y = C_B = C$ (say). Since the phase voltages V_{RN} , V_{YN} and V_{BN} have the same magnitude (of course, displaced 120° from one another), the capacitive currents I_R , I_Y and I_B will have the same value i.e.

$$I_R = I_Y = I_B = V_{ph}/XC \text{ in magnitude}$$

Where V_{ph} = Phase voltage (i.e. line-to-neutral voltage) XC = Capacitive reactance of the line to ground

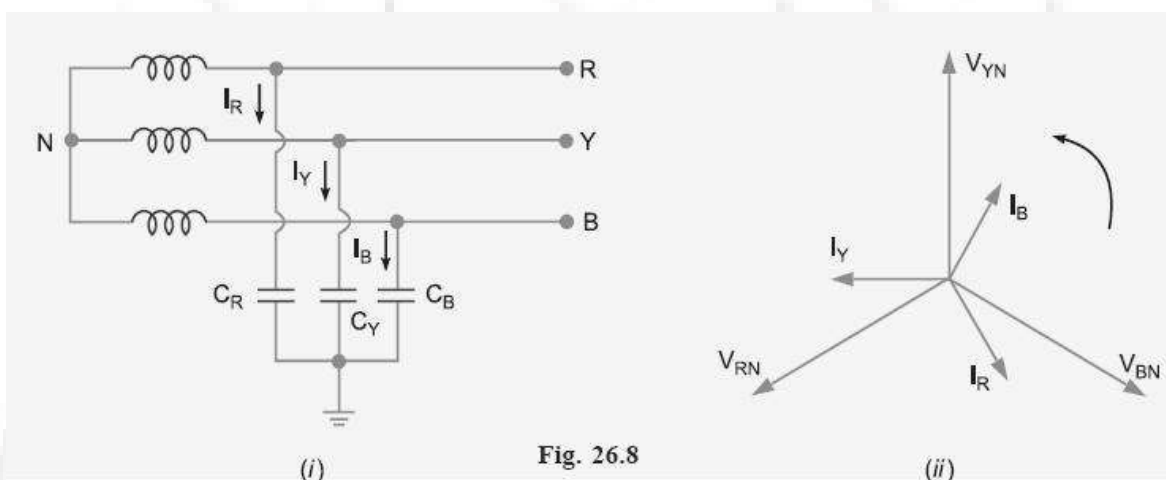

Fig. 26.8

The capacitive currents I_R , I_Y and I_B lead their respective phase voltages V_{RN} , V_{YN} and V_{BN} by 90° as shown in the phasor diagram in Fig. 26.8(ii). The three capacitive currents

are equal in magnitude and are displaced 120° from each other. Therefore, their phasor sum is zero. As a result, no current flows to ground and the potential of neutral is the same as the ground potential. Therefore, ungrounded neutral system poses no problems under normal conditions. However, as we shall see, currents and voltages are greatly influenced during fault conditions. Circuit behavior under single line to ground-fault. Let us discuss the behavior of ungrounded neutral system when single line to ground fault occurs. Suppose line to ground fault occurs in line B at some point F. The circuit then becomes as shown in Fig. 26.9(i). The capacitive currents I_R and I_Y flow through the lines R and Y respectively. The voltages driving I_R and I_Y are V_{BR} and V_{BY} respectively. Note that V_{BR} and V_{BY} are the line voltages [See Fig. 26.9 (ii)]. The paths of I_R and I_Y are essentially capacitive. Therefore,

Fault current in line B, $I_C = I_R + I_Y$ Phasor sum

Now, $I_R = \frac{V_{BR}}{X_C} = \frac{\sqrt{3} V_{ph}}{X_C}$

and $I_Y = \frac{V_{BY}}{X_C} = \frac{\sqrt{3} V_{ph}}{X_C}$

$\therefore I_R = I_Y = \frac{\sqrt{3} V_{ph}}{X_C}$

I_R leads V_{BR} by 90° and I_Y leads V_{BY} by 90° as shown in Fig. 26.9 (ii). The capacitive fault current I_C in line B is the phasor sum of I_R and I_Y .



YOUR TOOLS TO SUCCESS

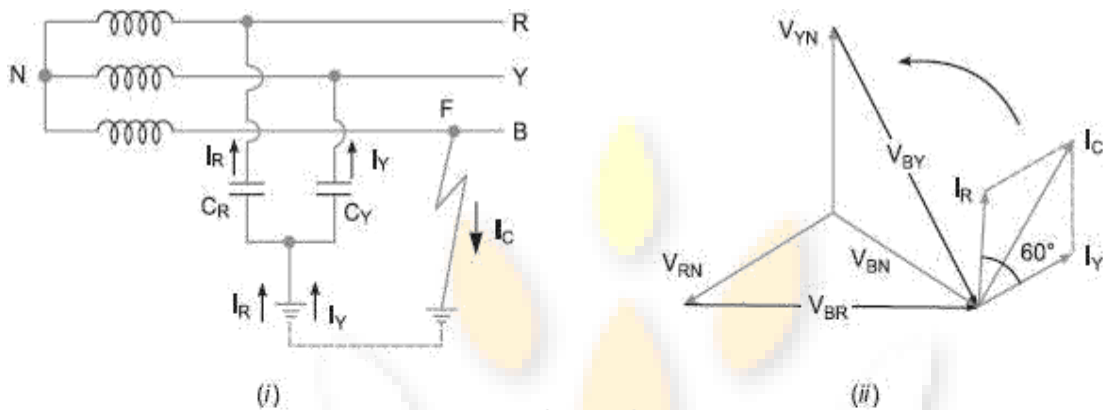

Fig. 26.9

$$= \sqrt{3} \times \text{Per phase capacitive current under normal conditions}$$

Capacitive fault current in line B is

$$\begin{aligned} I_C &= \text{Phasor sum of } I_R \text{ and } I_Y \\ &= \sqrt{3} I_R = \sqrt{3} \times \frac{\sqrt{3} V_{ph}}{X_C} = \frac{3V_{ph}}{X_C} \end{aligned}$$

$$\begin{aligned} I_C &= \frac{3V_{ph}}{X_C} = 3 \times \frac{V_{ph}}{X_C} \\ &= 3 \times \text{Per phase capacitive current under normal conditions} \end{aligned}$$

Therefore, when single line to ground fault occurs on an ungrounded neutral system, the following effects are produced in the system:

- ❖ The potential of the faulty phase becomes equal to ground potential. However, the voltages of the two remaining healthy phases rise from their normal phase voltages to full line value this may result in insulation breakdown.
- ❖ The capacitive current in the two healthy phases increase to 3 times the normal value.
- ❖ The capacitive fault current (I_C) becomes 3 times the normal per phase capacitive current.
- ❖ This system cannot provide adequate protection against earth faults. It is because the capacitive fault current is small in magnitude and cannot operate protective devices.
- ❖ The capacitive fault current I_C flows into earth, experience shows that I_C in excess of 4A is sufficient to maintain an arc in the ionized path of the fault. If this current is once maintained, it may exist even after the earth fault is cleared. This phenomenon of *persistent arc is called arcing ground. Due to arcing ground, the system capacity is charged and discharged in a cyclic order. This set up high frequency oscillations on the whole system and the phase voltage of healthy conductors may rise to 5 to 6 times its normal value. The over voltages in healthy conductors may damage the insulation in the line. Due to above disadvantages, ungrounded neutral system is not used these days. The modern high voltage 3-phase systems employ grounded neutral owing to a number of advantages.

NEUTRAL GROUNDING

The process of connecting neutral point of 3-phase system to earth (i.e. soil) either directly or through some circuit element (e.g. resistance, reactance etc.) is called neutral grounding.

Neutral grounding provides protection to personal and equipment. It is because during earth fault, the current path is completed through the earthed neutral and the protective devices (e.g. a fuse etc.) operate to isolate the faulty conductor from the rest of the system. This point is illustrated in Fig. 26.10.

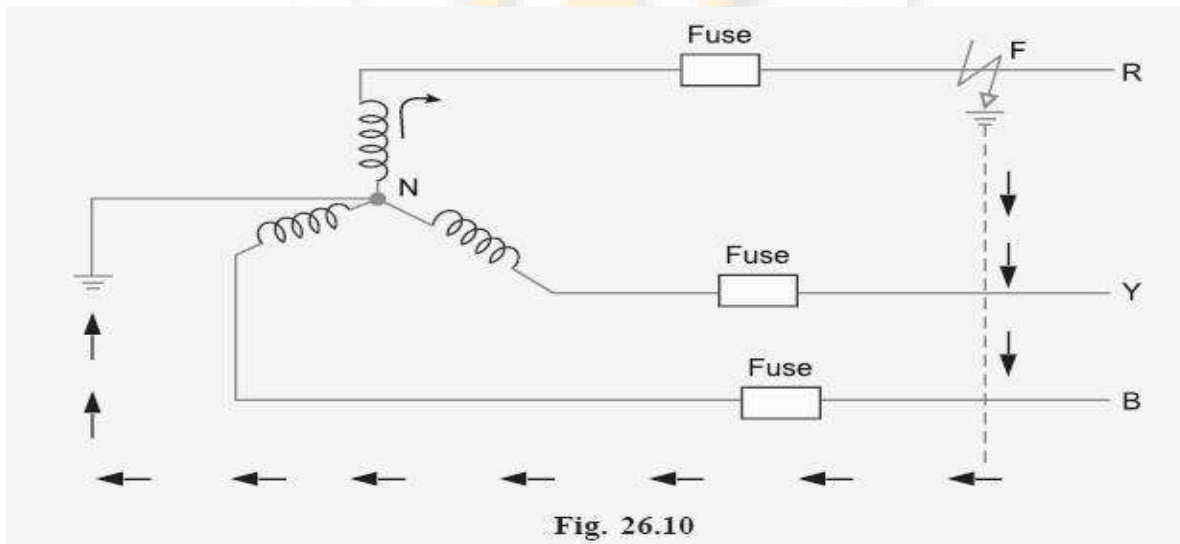

Fig. 26.10 shows a 3-phase, star-connected system with neutral earthed (i.e. neutral point is connected to soil).

Suppose a single line to ground fault occurs in line R-phase at point F. This will cause the current to flow through ground path as shown in Fig. 26.10. Note that current flows from R- phase to earth, then to neutral point N and back to R-phase. Since the impedance of the current path is low, a large current flows through this path. This large current will blow the fuse in R-phase and isolate the faulty line R. This will protect the system from the harmful effects (e.g. damage to equipment, electric shock to personnel etc.) of the fault. One important feature of grounded neutral is that the potential difference between the live conductor and ground will not exceed the phase voltage of the system i.e. it will remain nearly constant.

Advantages of Neutral Grounding

The following are the advantages of neutral grounding:

- Voltages of the healthy phases do not exceed line to ground voltages i.e. they remain nearly constant.
- The high voltages due to arcing grounds are eliminated.
- The protective relays can be used to provide protection against earth faults. In case earth fault occurs on any line, the protective relay will operate to isolate the faulty line.

- The over voltages due to lightning are discharged to earth.
- It provides greater safety to personnel and equipment.
- It provides improved service reliability.
- Operating and maintenance expenditures are reduced.

Note: It is interesting to mention here that ungrounded neutral has the following advantages:

- In case of earth fault on one line, the two healthy phases will continue to supply load for a short period.
- Interference with communication lines is reduced because of the absence of zero sequence currents.
- The advantages of ungrounded neutral system are of negligible importance as compared to the advantages of the grounded neutral system. Therefore, modern 3-phase systems operate with grounded neutral points.

METHODS OF NEUTRAL GROUNDING:

The methods commonly used for grounding the neutral point of a 3-phase system are :

1. Solid or effective grounding
2. Resistance grounding
3. Reactance grounding
4. Peterson-coil grounding

The choice of the method of grounding depends upon many factors including the size of the system, system voltage and the scheme of protection to be used.

SOLID GROUNDING:

When the neutral point of a 3-phase system (e.g. 3-phase generator, 3-phase transformer etc.) is directly *connected to earth (i.e. soil) through a wire of negligible resistance and reactance, it is called solid grounding or effective grounding. Fig. 26.11 shows the solid grounding of the neutral point. Since the neutral point is directly connected to earth through a wire, the neutral point is held at Fig. 26.11 earth potential under all conditions. Therefore, under fault conditions, the voltage of any conductor to earth will not exceed the normal phase voltage of the system.

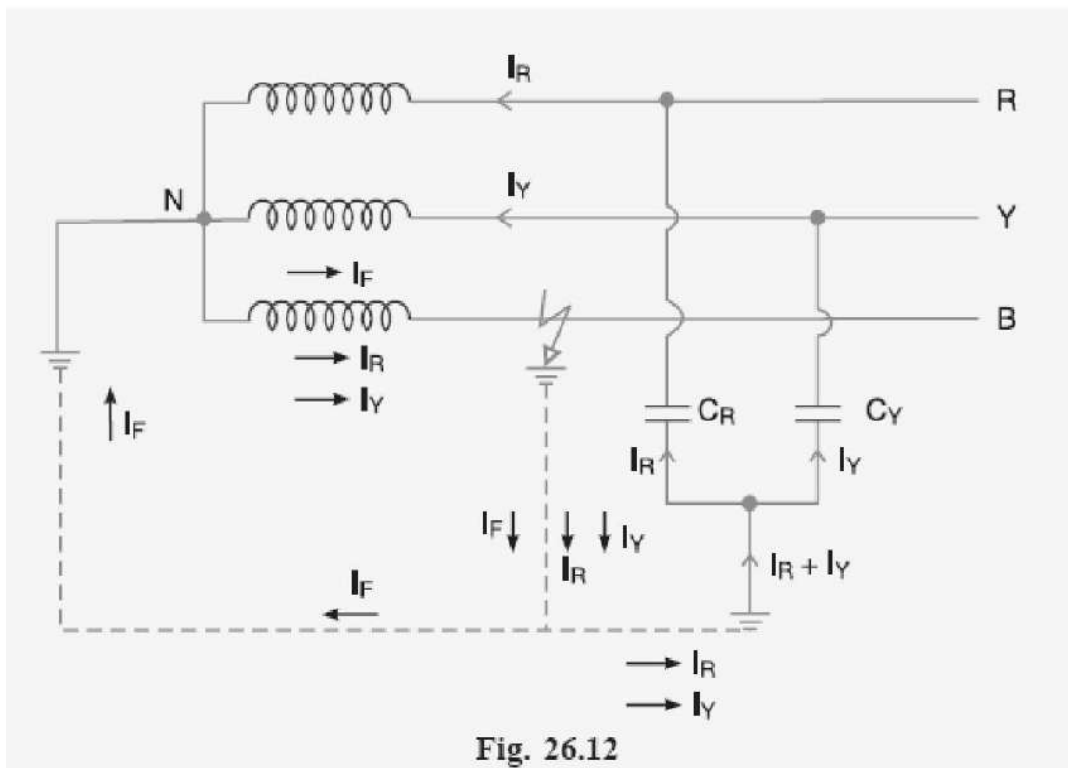
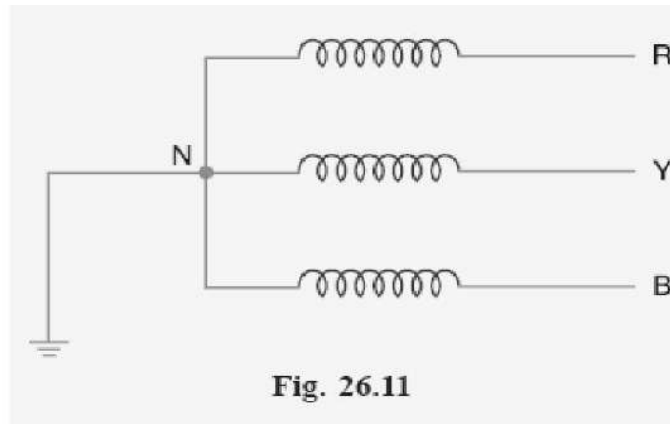

YOUR ROOTS TO SUCCESS...

The solid grounding of neutral point has the following advantages:

- The neutral is effectively held at earth potential.
- When earth fault occurs on any phase, the resultant capacitive current I_C is in phase opposition to the fault current I_F . The two currents completely cancel each other. Therefore, no arcing ground or over voltage conditions can occur. Consider a line to ground fault in line B as shown in Fig. 26.12. The capacitive currents flowing in the healthy phases R and Y are I_R and I_Y respectively. The resultant capacitive current I_C is the phasor sum of I_R and I_Y . In addition to these capacitive currents, the power source also supplies the fault current I_F .
- This fault current will go from fault point to earth, then to neutral point N and back to the fault point through the faulty phase. The path of I_C is capacitive and that of I_F is *inductive.
- The two currents are in phase opposition and completely cancel each other. Therefore, no arcing ground phenomenon or over-voltage conditions can occur.
- When there is an earth fault on any phase of the system, the phase to earth voltage of the faulty phase becomes zero. However, the phase to earth voltages of the remaining two healthy phases remain at normal phase voltage because the potential of the neutral is fixed at earth potential. This permits to insulate the equipment for phase voltage. Therefore, there is a saving in the cost of equipment.
- It becomes easier to protect the system from earth faults which frequently occur on the system. When there is an earth fault on any phase of the system, large fault current flows between the fault point and the grounded neutral. This permits the easy operation of earth fault relay.

The following are the disadvantages of solid grounding:

- Since most of the faults on an overhead system are phase to earth faults, the system has to bear a large number of severe shocks. This causes the system to become unstable.
- The solid grounding results in heavy earth fault currents. Since the fault has to be cleared by the circuit breakers, the heavy earth fault currents may cause the burning of circuit breaker contacts.
- The increased earth fault current results in greater interference in the neighboring communication lines.

Applications:

Solid grounding is usually employed where the circuit impedance is sufficiently high so as to keep the earth fault current within safe limits. This system of grounding is used for voltages upto 33 kV with total power capacity not exceeding 5000 kVA.

RESISTANCE GROUNDING:

In order to limit the magnitude of earth fault current, it is a common practice to connect the neutral point of a 3-phase system to earth through a resistor. This is called resistance grounding.

When the neutral point of a 3-phase system (e.g. 3-phase generator, 3-phase transformer etc.) is connected to earth (i.e. soil) through a resistor, it is called resistance grounding. Fig. 26.13 shows the grounding of neutral point through a resistor R . The value of R should neither be very low nor very high. If the value of earthing resistance R is very low, the earth fault current will be large and the system becomes similar to the solid grounding system. On the other hand, if the earthing resistance R is very high, the system conditions become similar to ungrounded neutral system. The value of R is so chosen such that the earth fault current is limited to safe value but still sufficient to permit the operation of earth fault protection system. In practice, that value of R is selected that limits the earth fault current to 2 times the normal full load current of the earthed generator or transformer.

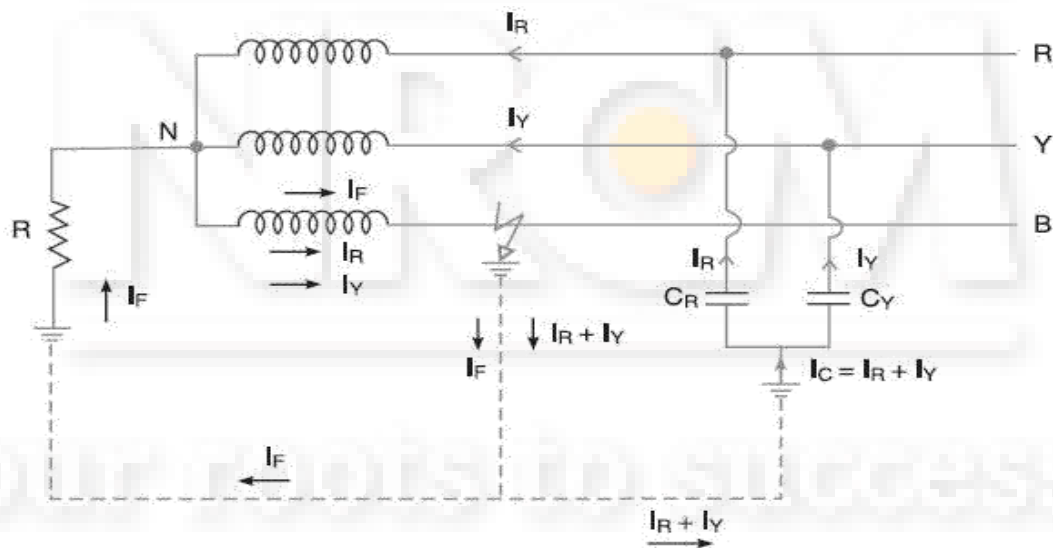
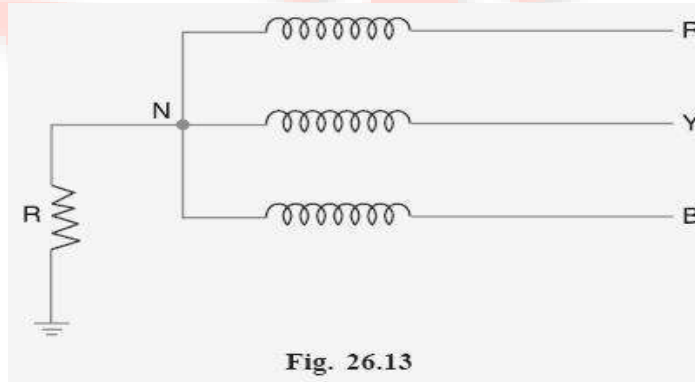

The following are the advantages of resistance earthing:

By adjusting the value of R , the arcing grounds can be minimised. Suppose earth fault occurs in phase B as shown in Fig. 26.14. The capacitive currents I_R and I_Y flow in the healthy phases R and Y respectively. The fault current I_F lags behind the phase voltage of the faulted phase by a certain angle depending upon the earthing resistance R and the reactance of the system upto the point of fault. The fault current I_F can be resolved into two components viz.

- (a) I_{F1} in phase with the faulty phase voltage.
 - (b) I_{F2} lagging behind the faulty phase voltage by 90° .
1. The lagging component I_{F2} is in phase opposition to the total capacitive current I_C . If the value of earthing resistance R is so adjusted that $I_{F2} = I_C$, the arcing ground is completely eliminated and the operation of the system becomes that of solidly grounded system. However, if R is so adjusted that $I_{F2} < I_C$, the operation of the system becomes that of ungrounded neutral system.
 2. The earth fault current is small due to the presence of earthing resistance. Therefore, interference with communication circuits is reduced.
 3. It improves the stability of the system.

The following are the disadvantages of resistance grounding:

1. Since the system neutral is displaced during earth faults, the equipment has to be insulated for higher voltages.
2. This system is costlier than the solidly grounded system.
3. A large amount of energy is produced in the earthing resistance during earth faults. Sometimes it becomes difficult to dissipate this energy to atmosphere.

Applications:

It is used on a system operating at voltages between 2.2 kV and 33 kV with power source capacity more than 5000 kVA.

REACTANCE GROUNDING:

In this system, a reactance is inserted between the neutral and ground as shown in Fig. 26.15. The purpose of reactance is to limit the earth fault current. By changing the earthing reactance, the earth fault current can change to obtain the conditions similar to that of solid grounding.

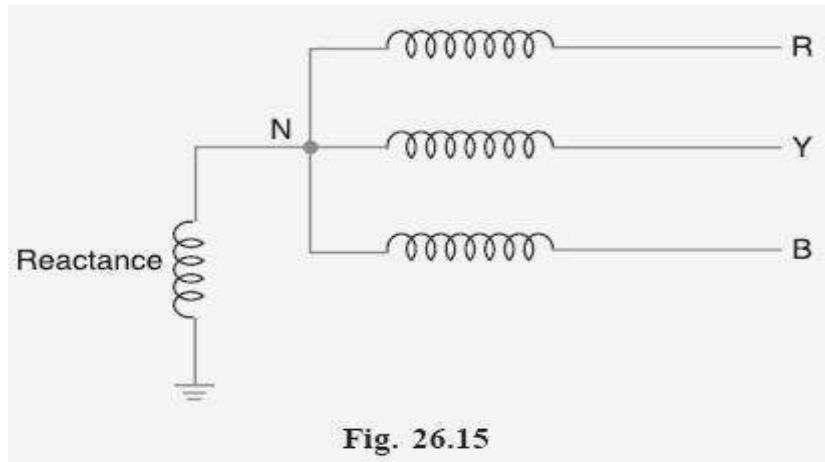

This method is not used these days because of the following disadvantages:

- In this system, the fault current required to operate the protective device is higher than that of resistance grounding for the same fault conditions.
- High transient voltages appear under fault conditions.

ARC SUPPRESSION COIL GROUNDING (OR RESONANT GROUNDING):

We have seen that capacitive currents are responsible for producing arcing grounds. These capacitive currents flow because capacitance exists between each line and earth. If inductance L of appropriate value is connected in parallel with the capacitance of the system, the fault current I_F flowing through L will be in phase opposition to the capacitive current I_C of the system. If L is so adjusted that $I_L = I_C$, then resultant current in the fault will be zero. This condition is known as resonant grounding. When the value of L of arc suppression coil is such that the fault current I_F exactly balances the capacitive current I_C , it is called resonant grounding.

CIRCUIT DETAILS:

An arc suppression coil (also called Peterson coil) is an iron-cored coil connected between the neutral and earth as shown in Fig. 26.16(i). The reactor is provided with tapplings to change the inductance of the coil. By adjusting the tapplings on the coil, the coil can be tuned with the capacitance of the system i.e. resonant grounding can be achieved.

OPERATION:

Fig. 26.16(i) shows the 3-phase system employing Peterson coil grounding. Suppose line to ground fault occurs in the line B at point F. The fault current I_F and capacitive currents I_R and I_Y will flow as shown in Fig. 26.16 (i). Note that I_F flows through the Peterson coil (or Arc suppression coil) to neutral and back through the fault. The total capacitive current I_C is the phasor sum of I_R and I_Y as shown in phasor diagram in Fig. 26.16(ii).

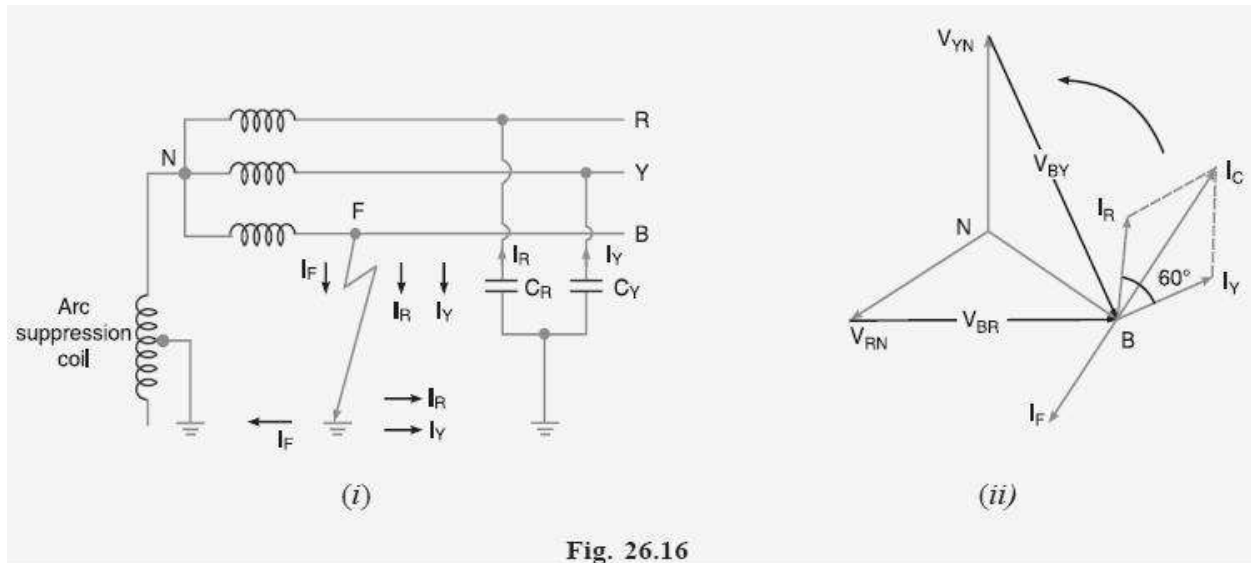

The voltage of the faulty phase is applied across the arc suppression coil. Therefore, fault current I_F lags the faulty phase voltage by 90° . The current I_F is in phase opposition to capacitive current I_C [See Fig. 26.16(ii)]. By adjusting the tapings on the Peterson coil, the resultant current in the fault can be reduced. If inductance of the coil is so adjusted that $I_L = I_C$, then resultant current in the fault will be zero. Value of L for resonant grounding. For resonant grounding, the system behaves as an ungrounded neutral system. Therefore, full line voltage appears across capacitors C_R and C_Y .

$$I_R = I_Y = \frac{\sqrt{3}V_{ph}}{X_C}$$

$$I_C = \sqrt{3} I_R = \sqrt{3} \times \frac{\sqrt{3}V_{ph}}{X_C} = \frac{3V_{ph}}{X_C}$$

Here, X_C is the line to ground capacitive reactance.

Fault current,
$$I_F = \frac{V_{ph}}{X_L}$$

Here, X_L is the inductive reactance of the arc suppression coil.

For resonant grounding, $I_L = I_C$

or
$$\frac{V_{ph}}{X_L} = \frac{3V_{ph}}{X_C}$$

or
$$X_L = \frac{X_C}{3}$$

or
$$\omega L = \frac{1}{3\omega C}$$

∴
$$L = \frac{1}{3\omega^2 C} \quad \dots(i)$$

Exp. (i) gives the value of inductance L of the arc suppression coil for resonant grounding

The Peterson coil grounding has the following advantages:

1. The Peterson coil is completely effective in preventing any damage by an arcing ground.
2. The Peterson coil has the advantages of ungrounded neutral system.

The Peterson coil grounding has the following disadvantages :

1. Due to varying operational conditions, the capacitance of the network changes from time to time. Therefore, inductance L of Peterson coil requires readjustment.
2. The lines should be transposed.

VOLTAGE TRANSFORMER EARTHING:

In this method of neutral earthing, the primary of a single-phase voltage transformer is connected between the neutral and the earth as shown in Fig. 26.17. A low resistor in series with a relay is connected across the secondary of the voltage transformer. The voltage transformer provides a high reactance in the neutral earthing circuit and operates virtually as an ungrounded neutral system. An earth fault on any phase produces a voltage across the relay. This causes the operation of the protective device.

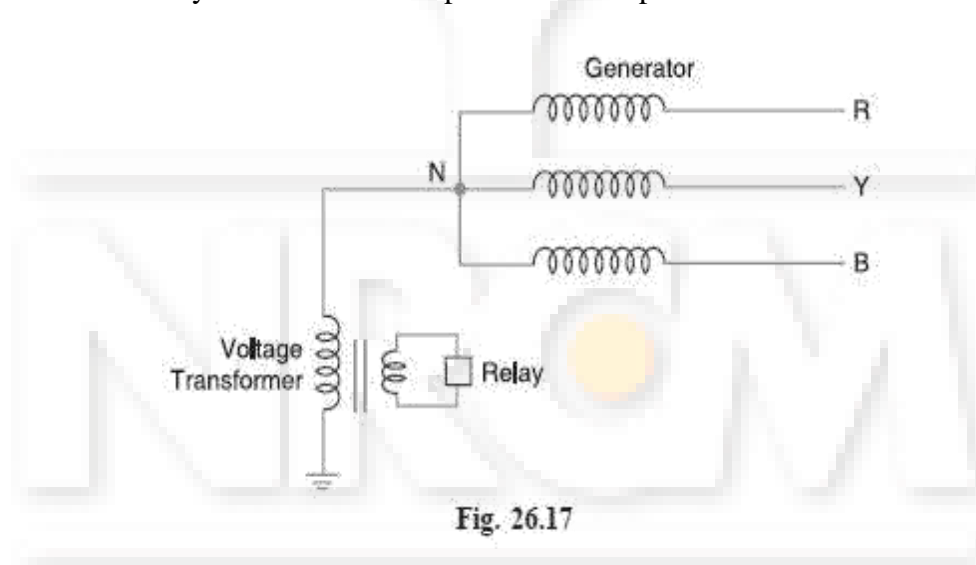

The following are the advantages of voltage transformer earthing :

1. The transient over voltages on the system due to switching and arcing grounds are reduced. It is because voltage transformer provides high reactance to the earth path.
2. This type of earthing has all the advantages of ungrounded neutral system.
3. Arcing grounds are eliminated.

The following are the disadvantages of voltage transformer earthing:

1. When earth fault occurs on any phase, the line voltage appears across line to earth capacitances. The system insulation will be overstressed.
2. The earthed neutral acts as a reflection point for the travelling waves through the machine winding. This may result in high voltage build up.

Applications:

The use of this system of neutral earthing is normally confined to generator equipments which are directly connected to step-up power transformers.

GROUNDING TRANSFORMER:

We sometimes have to create a neutral point on a 3-phase, 3-wire system (e.g. delta connection etc.) to change it into 3-phase, 4-wire system. This can be done by means of a grounding transformer. It is a core type transformer having three limbs built in the same fashion as that of the power transformer. Each limb of the transformer has two identical windings wound differentially (i.e. directions of current in the two windings on each limb are opposite to each other) as shown in

Fig. 26.18. Under normal operating conditions, the total flux in each limb is negligibly small. Therefore, the transformer draws very small magnetizing current

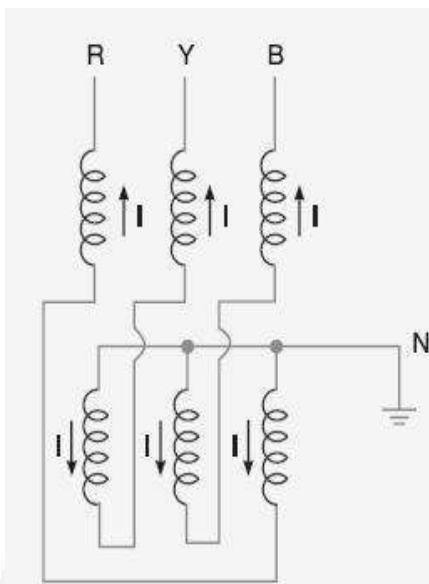

Fig. 26.18

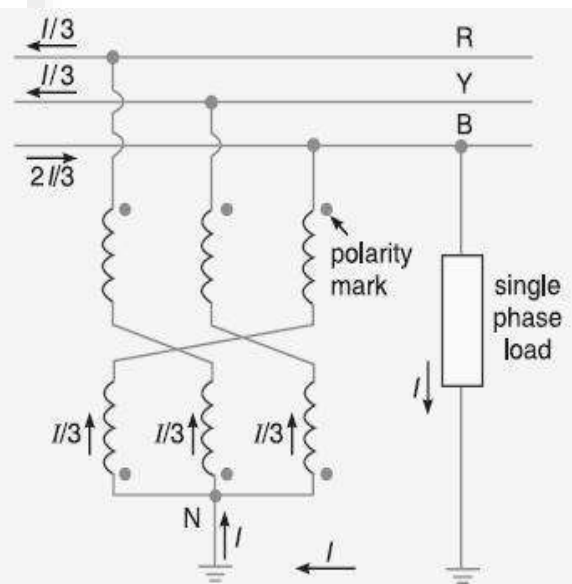

Fig. 26.19

Fig. 26.19 shows the use of grounding transformer to create neutral point N. If we connect a

single- phase load between one line and neutral, the load current I divide into three equal currents in each winding. Because the currents are equal, the neutral point stays fixed and the line to neutral voltages remain balanced as they would be on a regular 4-wire system. In practice, the single-phase loads are distributed as evenly as possible between the three phases and neutral so that unbalanced load current I is relatively small.

he impedance of grounding transformer is quite low. Therefore, when line to earth fault occurs, the fault current will be quite high. The magnitude of fault current is limited by inserting a resistance (not shown in the figure) in the neutral circuit. Under normal conditions, only iron losses will be continuously occurring in the grounding transformer. However, in case of fault, the high fault current will also produce copper losses in the transformer. Since the duration of the fault current is generally between 30-60 seconds, the copper losses will occur only for a short interval.

Grounding Practice:

1. Once the grounding is normally provided at each voltage level. Between generation and distribution, there are various voltage levels. It desirable to have ground available at each voltage level.
2. The generation is normally provided with resistance grounding and synchronous capacitors are provided with reactance grounding.
3. Where several generators are connected to a common neutral bus. The bus is connected to ground through a single grounding device. Disconnect switches can be used to ground the desired generators to the neutral bus.
4. Where the several generators are operating in parallel, only one generator neutral is grounded. This is done to avoid the interference of zero sequence components. Normally two grounds are available in a station but only one is used at a time. The other is used when the first generator is out of service.
5. For low voltages up to 600 volts and for high voltages above 33 KV solid grounding is used whereas for medium voltage between 3.3 KV and 33 KV resistance or reactance grounding is used.

UNIT - V

PROTECTION AGAINST OVER VOLTAGES

8.1 GENERATION OF OVER VOLTAGE IN POWER SYSTEM

The generation of over voltages in power system can be classified into two categories.

1. External over voltages
2. Internal over voltages

These two categories are discussed briefly.

1. External over Voltages

The over voltages caused due to disturbances in atmosphere is termed as external over voltages. They do not depend on the system operating voltage.

The causes for over voltages are

- a) Direct lighting strokes
- b) Over voltages caused by electromagnetic induction due to lighting discharge taking place near the live
- c) Electrostatically induced over voltage due to frictional effect of dust or snow in the atmosphere
- d) Electrostatically induced over voltages due to clouds in the atmosphere
- e) The transmission line is lengthy such that it is subjected to various atmospheric conditions. Due to this over voltages are induced.

2. Internal Over Voltages

Internal over voltages are caused due to changes in the operating conditions of the system. These are further divided into two types.

(i) Transient Overvoltages (Switching Overvoltages)

Transient overvoltages are caused due to transient nature of the system during switching operations or fault conditions. The transient overvoltages are oscillatory with a frequency ranging from few hundred to few KHZ,

Eg:-

- 1) Due to switching of transformer at no load
- 2) Due to fault in one phase, the voltage of healthy phases shoots up

3) Due to closing of circuit breaker contacts to clear a fault which is followed by appearance of restriking voltage. Transient overvoltages are of relatively high frequency

Here we define a term called over-voltage factor. It is the ratio of peak overvoltage to the rated system-frequency phase voltage. This term is also called as amplitude factor.

(ii) Temporary Overvoltages (Steady-State Overvoltages)

These overvoltages are the steady-state over voltages of the system. These over-voltages are of power frequency.

The main cause of steady-state over voltages is due to the disconnection of loads.

The over voltages mentioned above causes damage to the equipment and also insulation of the system, so the system should be protected against these over voltages. The type of protection depends on the factors causing over voltages and also the magnitude, shape and frequency of occurrence of the over voltages.

8.2 PROTECTION AGAINST LIGHTNING OVER VOLTAGES:-

Lightning causes two kinds of over voltages. They are

1. by direct stroke to a line conductor
2. Electromagnetically induced over voltages due to indirect stroke i.e lightning discharge taking place near the line

The over voltages caused due to direct lightning stroke is more severe than due to indirect lightning stroke.

The direct lightning strokes can be approximated to a constant current source since current through the phase conductor due to direct lightning stroke is constant

The transmission lines can be protected against lightning over voltages using lightning arresters or surge diverters.

The surge diverter are connected between line and ground at the substation

These act in parallel with the equipment to be protected, and protects it by

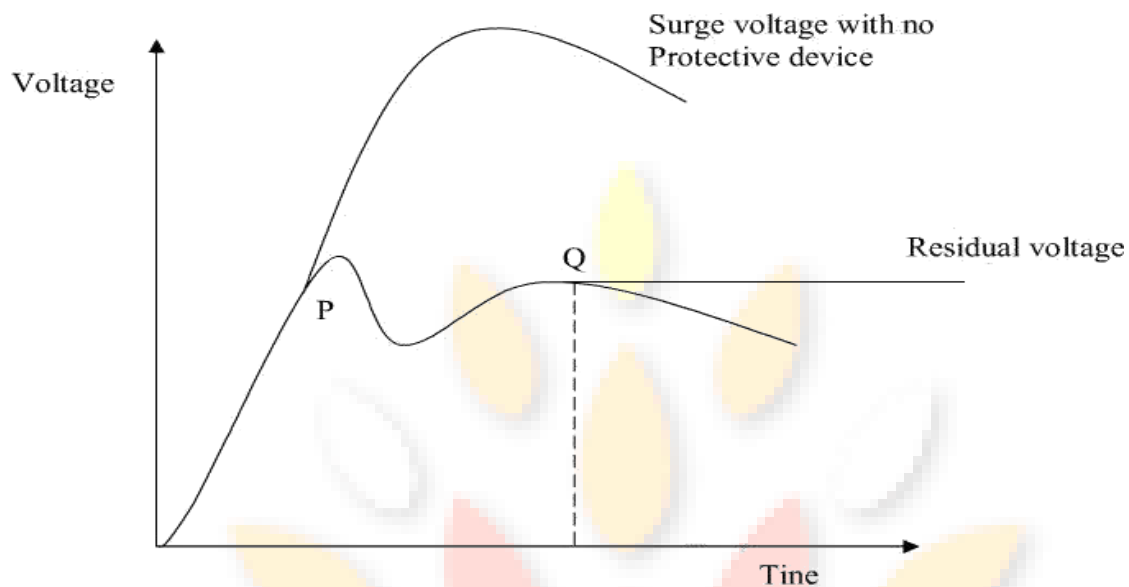

Fig
-8.1

When the traveling wave reaches the diverter, the diverter provides a relatively low impedance path to ground for the surge current. This current limits the amplitude of the over voltage across the line known as residual voltage to a value which protects the insulation of equipment

The characteristics of ideal lightning arrester is

- (i) During normal operations it should not draw any current
- (ii) During transients, it should create low-impedance path for the surge currents
- (iii) The discharge current through the diverter should not be so large such that it damages the surge diverter itself

Impulse Ratio

Impulse ratio is defined as the ratio of the breakdown impulse voltage of a wave of specified duration to the breakdown voltage of a power-frequency wave.

Impulse ratio is a function of time duration of the transient wave.

Two types of lightning arresters are discussed below.

8.2.1 Valve Type Lightning Arrester

This type of diverter is also called Non-linear surge diverter. The construction of valve type lightning arrester is shown below.

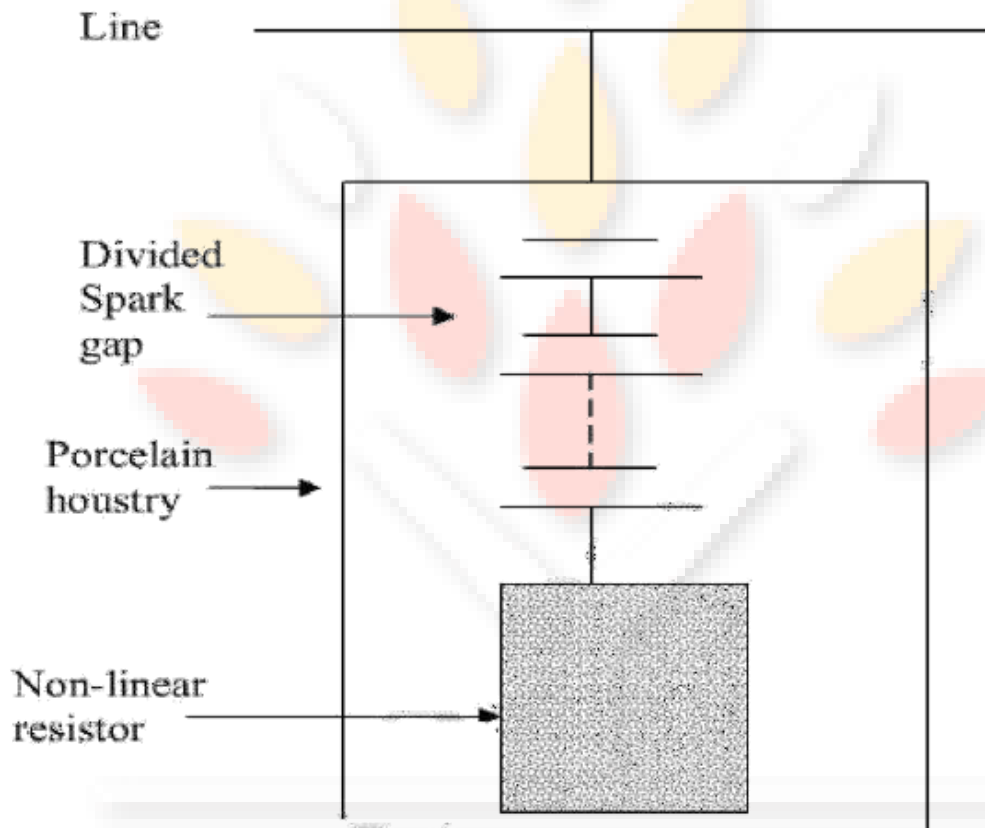

Fig 8.2

It consists of a divided spark gap and a non-linear resistor in series. Divided spark gap consists of number of short gaps in series. These are enclosed in a leaktight porcelain housing.

The divided spark gap consists of several short gaps in series. Each gap has two electrodes and a high resistance is connected across it. The high resistance provides grading of voltage between the various gaps. The resistance connected also raises the interrupting capacity of the divided spark gap.

The function of the divided spark-gap of the diverter is listed below

- i) Under normal conditions, it prevents the flow of current through the diverter
- ii) It sparks over at a predetermined voltage
- iii) It makes the diverter to be capable of interrupting the power frequency follow up current after the surge is discharged to ground

The functions of the non-linear resistors are listed below

- i) They provide a high resistance path for the flow of power frequency follow up current
- ii) A low impedance path is provided for the flow of surge current
- iii) Non-linear resistor provides the dissipating of surge energy

The figure drawn below shown a typical valve type lightning arrester

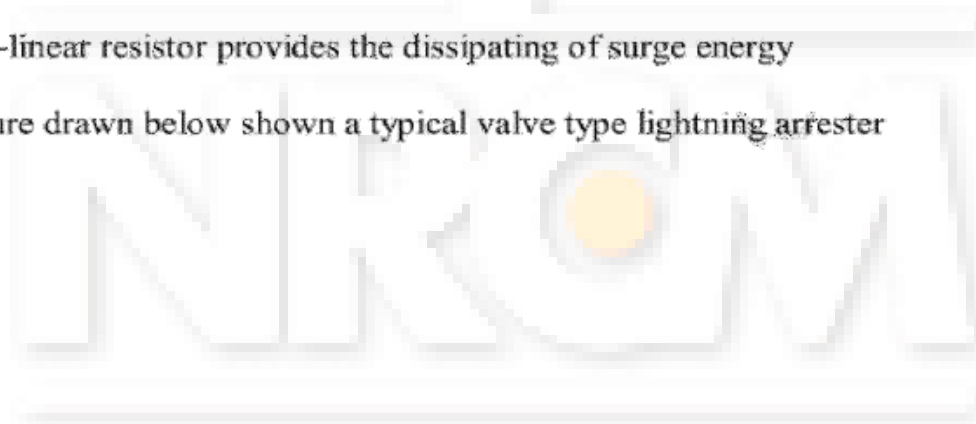

YOUR TOOLS TO SUCCESS...

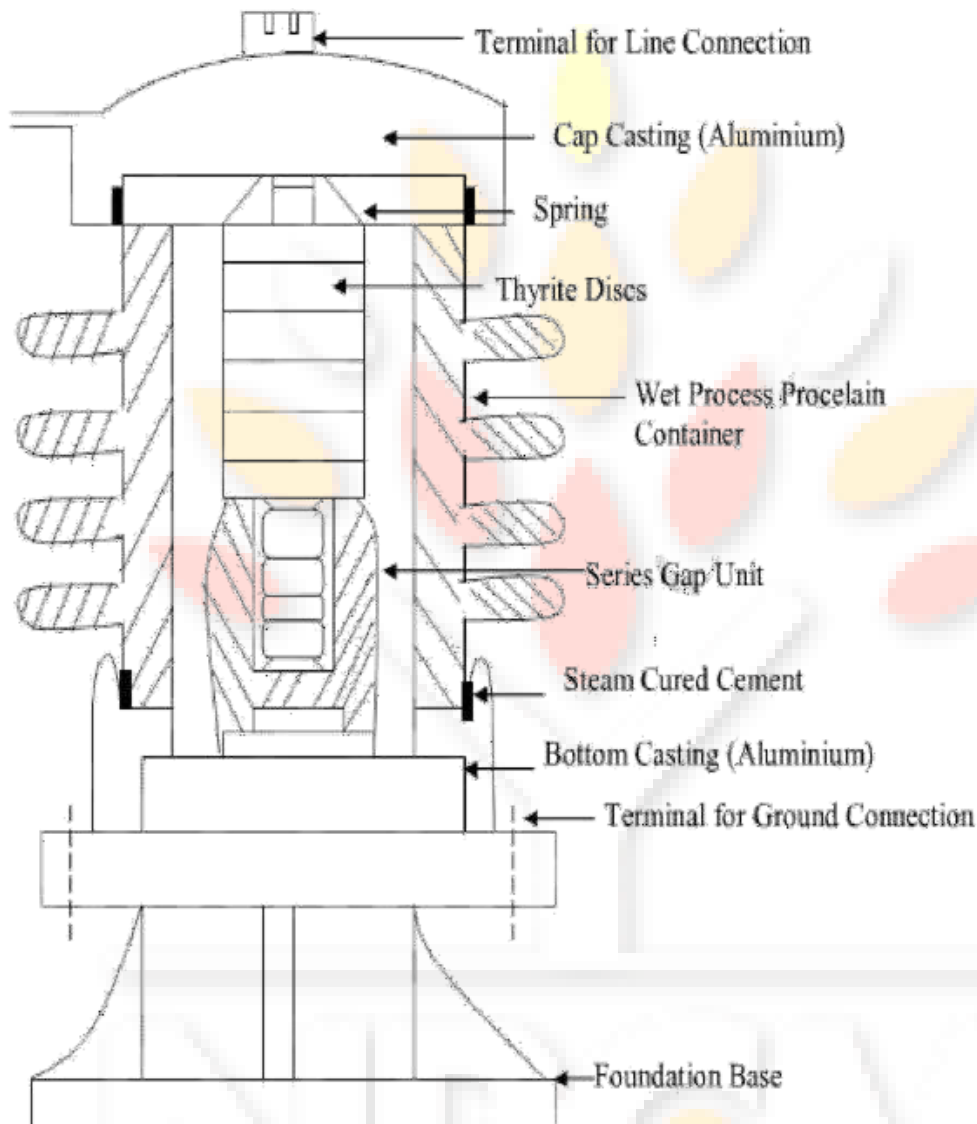

Figure 8.3

Since non-linear resistor changes its resistance inversely proportional to current to maintain voltage constant its ideal characteristics is $RI = \text{constant}$

The non-linear resistor is made up of material named 'thyrite', this type of lightning arrester is also known as 'Thyrite type lightning arrester'

The figure drawn below shown

Volt-ampere characteristics of the non-linear diverter

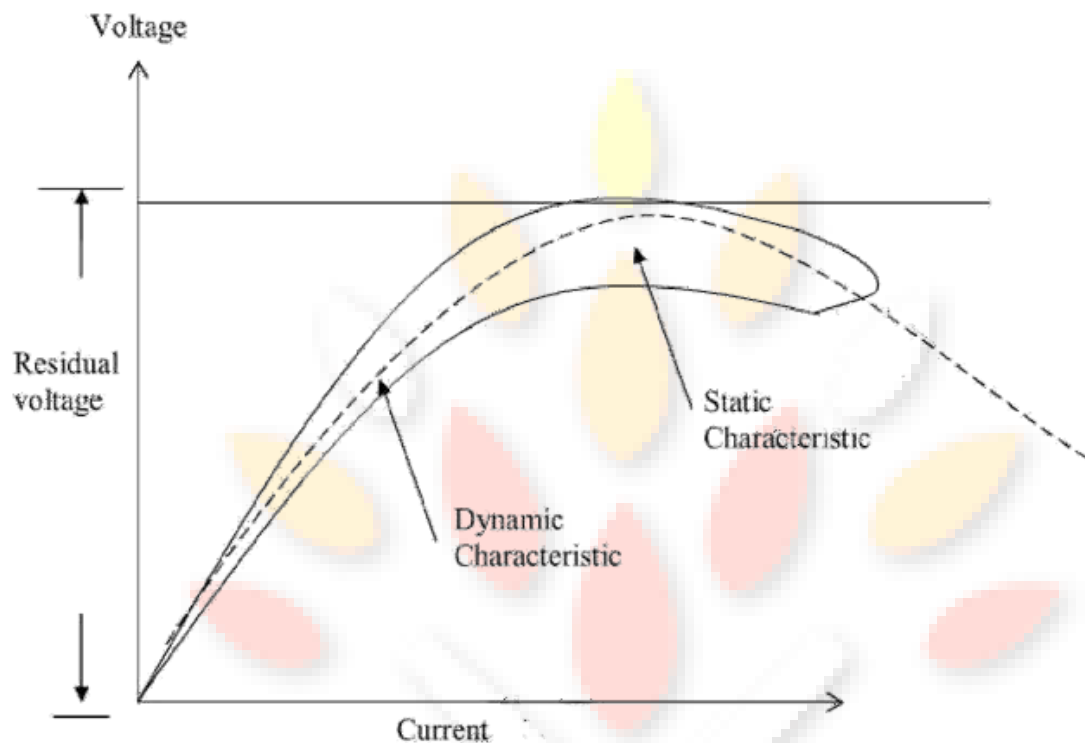

Fig 8.4

The static characteristic is shown by the dotted curve and the dynamic characteristic is shown by the solid curve. The tangent drawn to the dynamic characteristic intersects the voltage axis at a value called “residual voltage”

Hence residual voltage is defined as the “peak value of the voltage between the terminals of the surge diverter at the instant when the surge current discharges through it”.

This type of lightning arrester acts as an insulator at normal working conditions. When there are voltage surges, it creates a low impedance path to the surge currents. After the voltage surges has disappeared, again it acts as an insulator.

Since its function is similar to the valve opening at high surge currents it is called valve type lightning arrester.

8.2.2 Zinc-Oxide Lightning Arrester

The conventional non-linear lightning arresters use silicon carbide (SiC) as the non-linear resistor. But this material does not exhibit ideal non-linear characteristics and there are some design restrictions.

The Zinc-Oxide lightning arrester uses a series of Zinc-Oxide (ZnO) elements in addition with Oxides such as cobalt Oxide, bismuth with out series spark gaps.

Zinc-Oxide element has high degree of non-linearity. Their volt-ampere characteristics are very close to idea.

The lightning arrester which uses Zinc-Oxide element as non-linear resistor is known as metal Oxide surge arrester (MOA)

The operation of Metal Oxide surge arrester is explained in the following points

- (i) At normal conditions, the peak value of phase to ground voltage is less than the sum of the rated voltage of the discs (elements)
- (ii) When an over-voltage occurs, surge current through it rises and it comes into complete conducting state.
- (iii) When the voltage transient disappear, the current through it decreases following the V-I characteristics.

The characteristics of MOA and conventional non-linear arrester in response to surge $V(t)$ is shown below

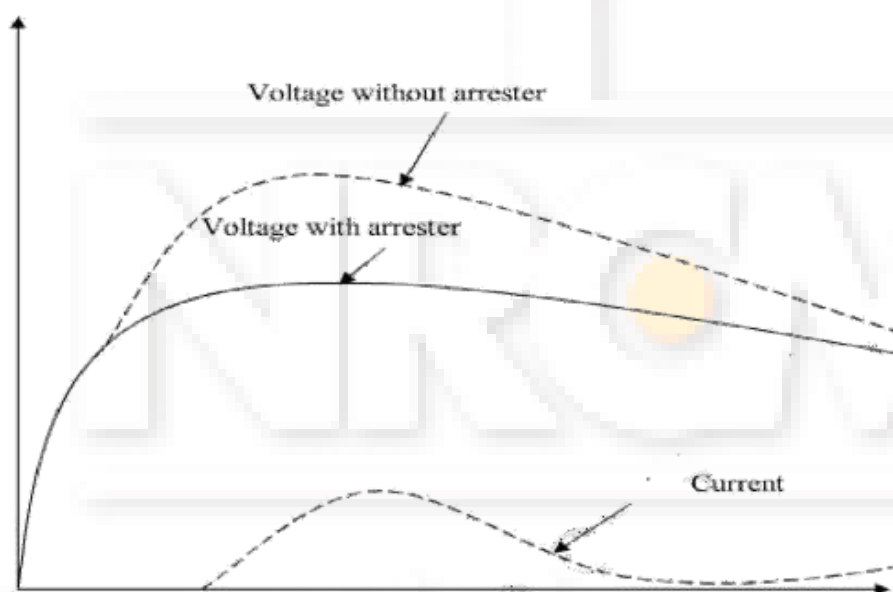

Fig 8.5(a)

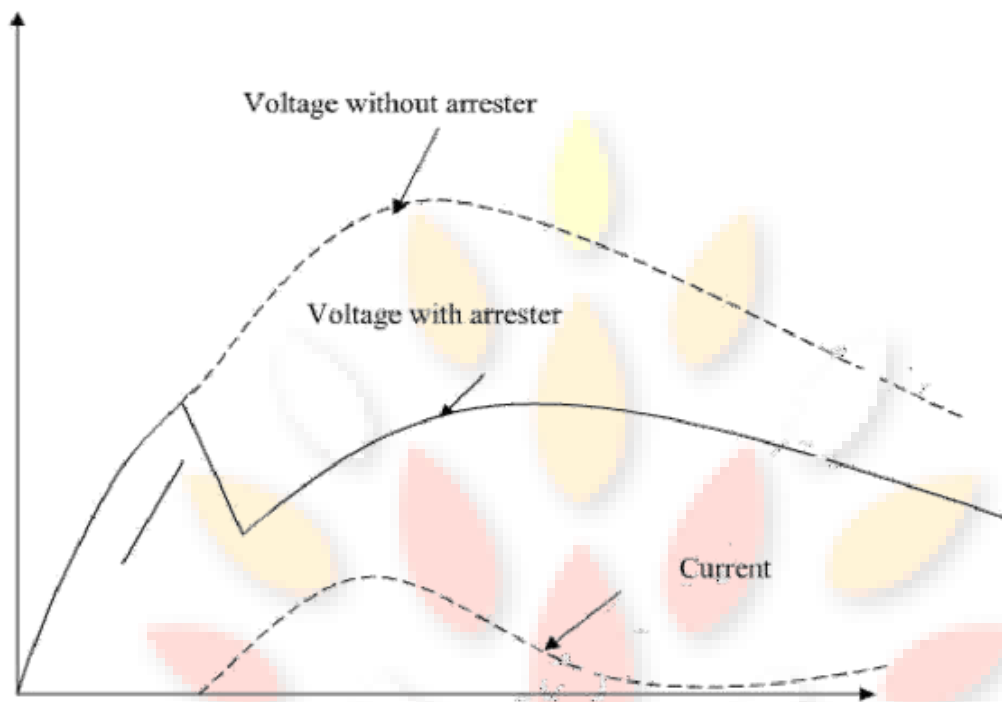

Fig 8.5(b)

Notice that in MOA there is no follow up current

The voltage of MOA expressed as

$$V = 2v(t) - Z_0 i \quad (1)$$

Where Z_0 is the surge impedance and i is the instantaneous current of the arrester. At the time of spark over in a conventional arrester, the voltage is at its peak value known as spark over voltage. After spark over it follows equation

$$V = 2v(t) - Z_0 i$$

From the above discussion we can say that the performance of MOA depends only on discharge voltage but the performance of conventional arrester depends both on spark over voltage and discharge voltage.

Since the protection level of MOA is controlled by maximum discharge voltage, the relation between voltage and current can be expressed as

$$V = v(i) \quad (2)$$

By combining equations (1) and (2) the time dependence of V can be calculated. This can be solved graphically as shown in the figure (a) drawn below.

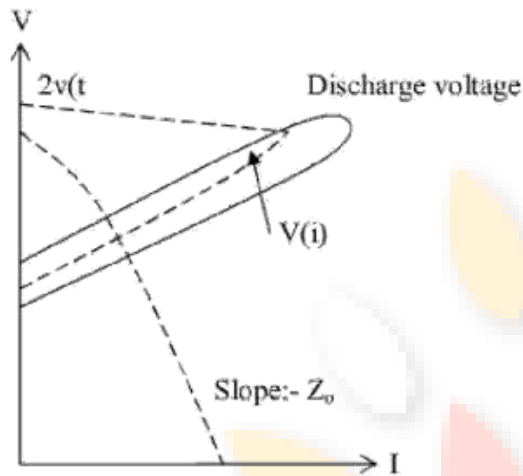

Fig 8.6(a)

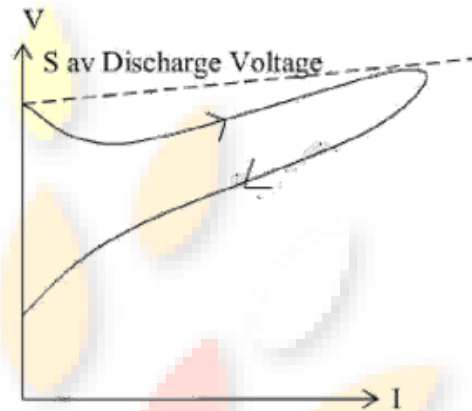

Fig 8.6(b)

Point P_0 in MOA to represent values of V and I corresponding to $v(t)$. It is the intersection point of two curves which is represented by equations (1) and (2). It slides over $v(i)$ curve. The point P moves over the thick line shown in the figure.

The V I characteristics of conventional arrester is shown in figure (6)

The advantages of Zinc-Oxide surge arrester are as follows

- (i) It is a fully solid-state arrester
- (ii) It is suitable for protection of system up to highest voltages
- (iii) Spark gaps are not required
- (iv) Transients do not occur at spark over
- (v) Power follow-up current is negligible after surge operation
- (vi) Its operating time is less

8.3 INSULATION COORDINATION

Definition:-

Insulation coordination is defined as the correlation of the insulation of electrical equipment and lines with the characteristics of protective devices such that the insulation of the whole power system is protected from excessive over voltages.

It chooses a suitable value of insulation level for a protective system and arranges in such a manner such that the equipment is protected from over voltages.

The insulation level of equipment (eg:- transformer) should be higher than that of protective devices (eg:- surge arrester)

The volt-time curve of protective device (curve A) and equipment to be protected (curve B) is shown below



From the above figure we can infer that any equipment whose insulation strength is greater than insulation strength of curve B will be protected by protective device of curve A.

8.3.1 Volt-Time Characteristics

The volt-time characteristics of a particular insulation is a graph of its crest flash over voltage plotted against time of flash over for a series of impulse application of a given wave shape.

A series of impulse voltages of the same wave shape but different peak values is applied to the insulation and the volt-time of the insulation is plotted as shown in the figure drawn below

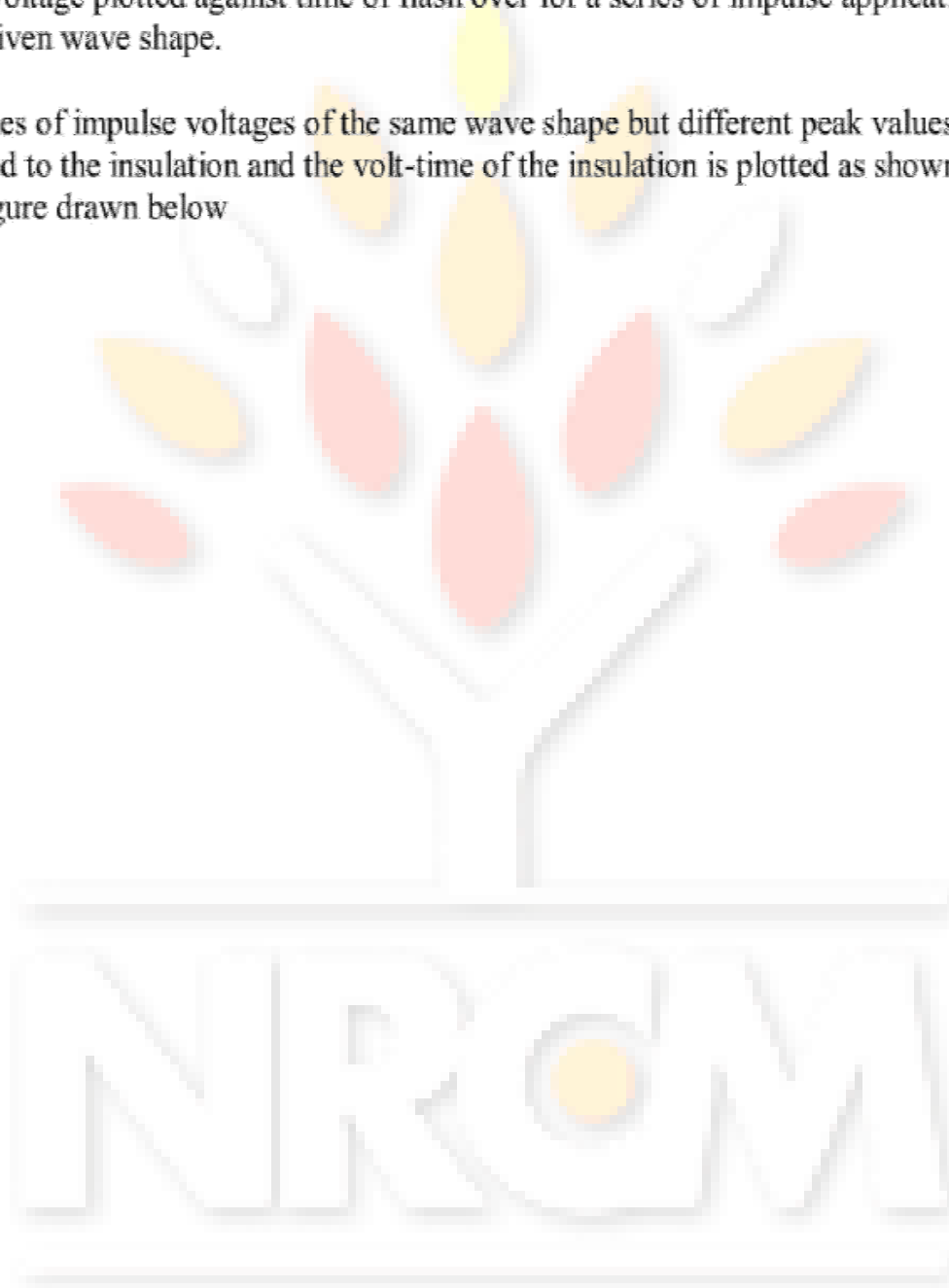

YOUR ROOTS TO SUCCESS...

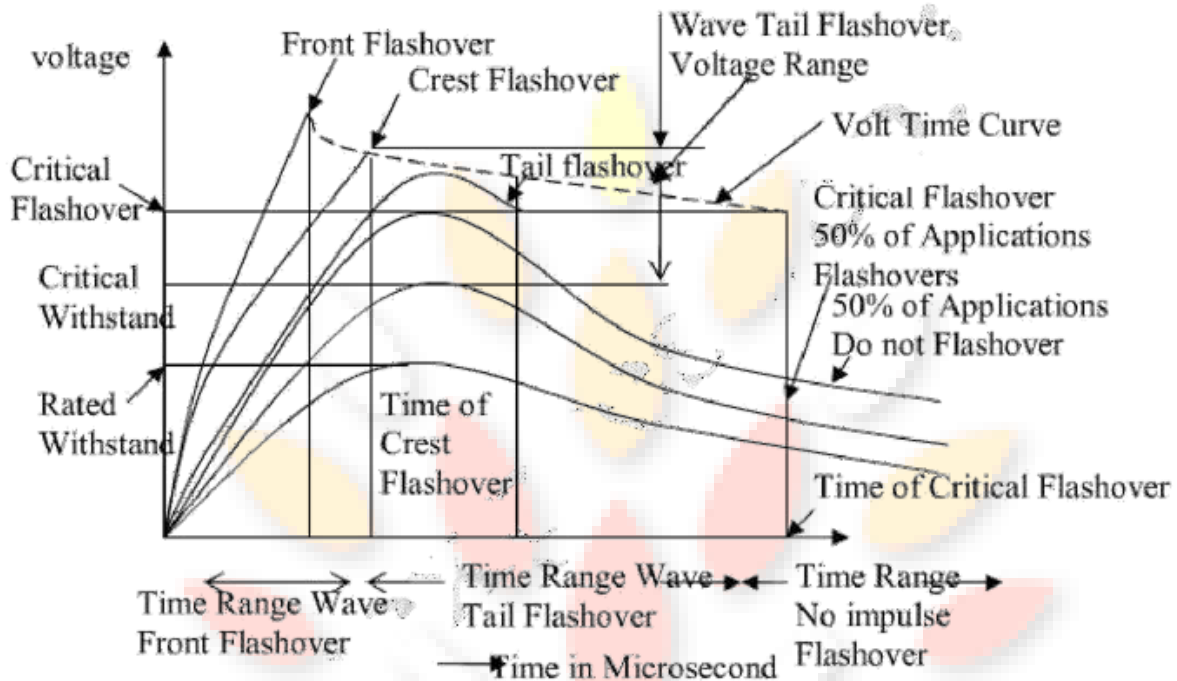

Figure 8.7

If an impulse voltage of given wave shape is applied to a particular insulation and its peak value is adjusted such that it flasher at the front of the wave, then the voltage at point at which front flash over occurs is called front flash over.

If peak value is such that it fails to flash over for 50% of application but flashes over at tail of the wave to other 50% of applications, the peak value of this voltage is called critical flash over.

For an impulse wave, if flash over doesn't take place, then it is called full wave and if flash over takes place then it is called chopped wave.

If the impulse wave is such that its voltage is just below the flash over voltage of the insulation then the voltage called critical with stand voltage.

The peak of impulse wave such that the insulation with stand without disruptive discharge is called rated with stand.

The terminology associated with impulse testing is shown in the figure 8.7

8.3.2 Standard Impulse Test Wave

The standard impulse test wave is obtained from various studies and used for laboratory tests of equipment for proving the with stand capabilities.

The standard impulse test wave for laboratory test wave is shown below

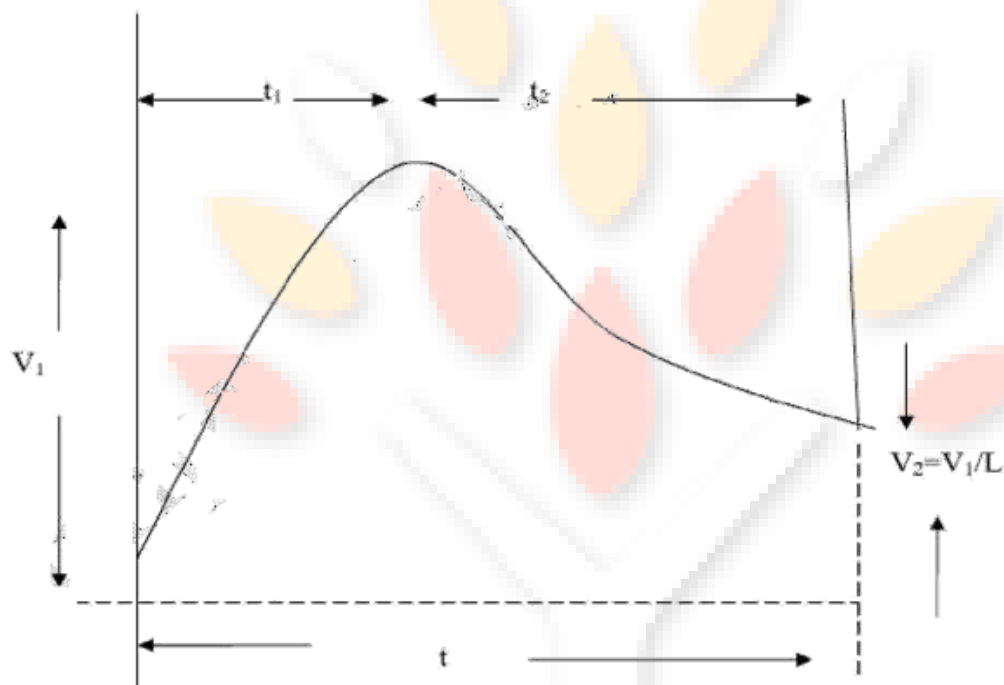

Fig 8.8

In the above figure
For lightning impulse test wave

$$t_1 = 1.2 \mu s$$

$$t_2 = 50 \mu s$$

For switching impulse test wave

$$t_1 = 250 \mu s$$

$$t_2 = 2500 \mu s$$

The peak value of the test wave vary widely

8.3.3 Basic Impulse Insulation Level (BIL)

Definition:-

BIL is the reference value of the peak voltage expressed in KV with standard 1.2/50 μ s lightning impulse wave

The insulation of equipment should with stand the test waves equal to greater than BIL

The BIL for a system to be protected is selected such that the it is protected by suitable lightning protective device.

8.3.4 Impulse Ratio

Impulse ratio for the cause of failure of insulation or flash over is defined as the ratio of 'peak value impulse voltage' to the peak value of power frequency voltage wave to cause the failure of insulation or flash over

$$\text{impuseratio} = \frac{\text{Peakvalueofimpulsevoltage}}{\text{peakvalueofpowerfrequencyvoltagewavetocausetheflashoverorfailureofinsulation}}$$

Surge Diverter | Lightning Arrester Types:

The earthing screen and ground wires can well protect the electrical system against direct lightning strokes but they fail to provide protection against travelling waves which may reach the terminal apparatus. The Lightning Arresters or surge diverter provide protection against such surges.

A lightning arresters or a surge diverter is a protective device which conducts the high voltage surges on the power system to the ground.

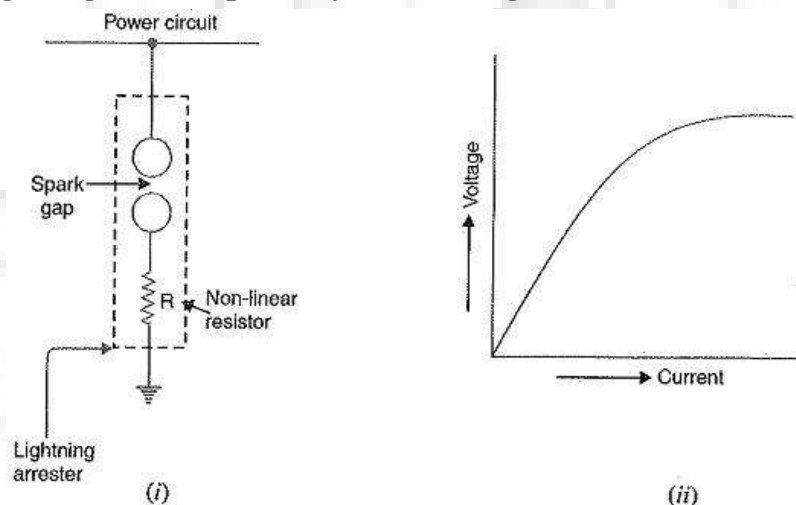

Fig. 24.8

Lightning Arrester Working:

Fig. 24.8 (i) shows the basic form of a surge diverter. It consists of a spark gap in series with a non-linear resistor. One end of the diverter is connected to the terminal of the equipment to be protected and the other end is effectively grounded. The length of the gap is so set that normal line voltage is not enough to cause an arc across the gap but a dangerously high voltage will break down the air insulation and form an arc. The property of the non-linear resistance is that its resistance decreases as the voltage (or current) increases and vice-versa. This is clear from the *volt/amp characteristic of the resistor shown in Fig. 24.8 (ii).

The action of the lightning arresters or surge diverter is as under:

- Under normal operation, the lightning arrester is off the line i.e. it conducts no current to earth or the gap is non-conducting.
- On the occurrence of overvoltage, the air insulation across the gap breaks down and an arc is formed, providing a low resistance path for the surge to the ground. In this way, the excess charge on the line due to the surge is harmlessly conducted through the arrester to the ground instead of being sent back over the line.
- It is worthwhile to mention the function of non-linear resistor in the operation of arrester. As the gap sparks over due to overvoltage, the arc would be a short circuit on the power system and may cause power-follow current in the arrester. Since the characteristic of the resistor is to offer high resistance to high voltage (or current), it prevents the effect of a short circuit. After the surge is over, the resistor offers high resistance to make the gap non-conducting.

Two things must be taken care of in the design of lightning arresters. Firstly, when the Surge Diverter is over, the arc in gap should cease. If the arc does not go out, the current would continue to flow through the resistor and both resistor and gap may be destroyed. Secondly, $I R$ drop (where I is the surge current) across the arrester when carrying surge current should not exceed the breakdown strength of the insulation of the equipment to be protected.

Types of Lightning Arresters:

There are several Types of Lightning Arresters in general use. They differ only in constructional details but operate on the same principle viz. providing low resistance path for the surges to the ground. We shall discuss the following Types of Lightning Arresters:

1. **Rod Gap Arrester**
2. **Horn Gap Arrester**
3. **Multi Gap Arrester**
4. **Expulsion Type Lightning Arrester**
5. **Valve Type Lightning Arrester**

1. ROD GAP ARRESTER:

It is a very simple Line type of diverter and consists of two 1.5 cm rods which are bent at tight angles with a gap in between as shown in Fig. 24.9. One rod is connected to the line circuit and the other rod is connected to earth. The distance between gap and insulator Transformer distance must not be less than one-third of the gap length so that the arc may not reach the insulator and damage it. Generally, the gap length is so adjusted that breakdown should occur at 80% of spark-over voltage in order to avoid cascading of very steep wave fronts across the insulators. The string of insulators for an overhead line on the bushing of transformer has frequently a rod gap across it. Fig. 24.9 shows the rod gap across the bushing of a transformer.

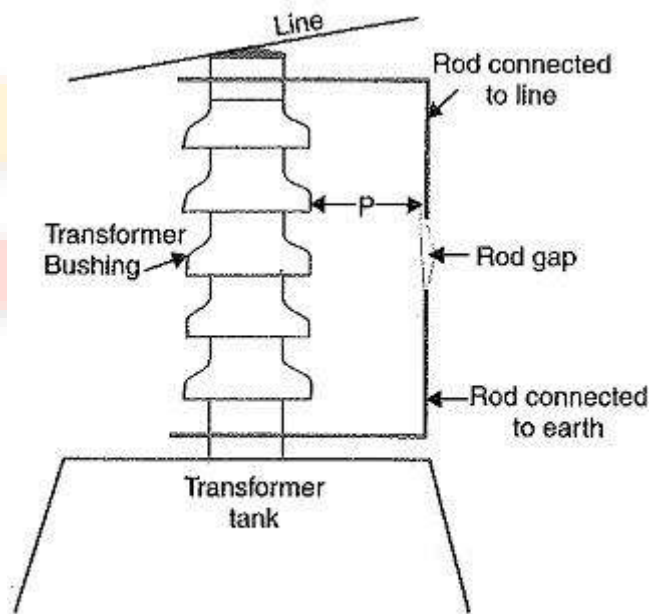

Fig. 24.9

Under normal operating conditions, the gap remains non-conducting. On the occurrence of a high voltage surge on the line, the gap sparks over and the surge current is conducted to earth. In this way, excess charge on the line due to the surge is harmlessly conducted to earth.

Limitations

- After the surge is over, the arc in the gap is maintained by the $\frac{1}{3}$ normal supply voltage, leading to a short-circuit on the system.
- The rods may melt or get damaged due to excessive heat produced by the arc.
- The climatic conditions (e.g. rain, humidity, temperature etc.) affect the performance of rod gap arrester.
- The polarity of the surge also affects the performance of this arrester.

Due to the above limitations, the rod gap arrester is only used as a 'tack-up' protection in case of main arresters.

2. HORN GAP ARRESTER:

Fig. 24.10 shows the horn gap arrester. It consists of two horn shaped metal rods A and B separated by a small air gap. The horns are so constructed that distance between them gradually increases towards the top as shown. The horns are mounted on porcelain insulators.

One end of horn is connected to the line through a resistance R and choke coil L while the other end is effectively grounded. The resistance R helps in limiting the follow current to a small value. The choke coil is so designed that it offers small reactance at normal power frequency but a very high reactance at transient frequency. Thus the choke does not allow the transients to enter the apparatus to be protected. The gap between the horns is so adjusted that normal supply voltage is not enough to cause an arc across the gap.

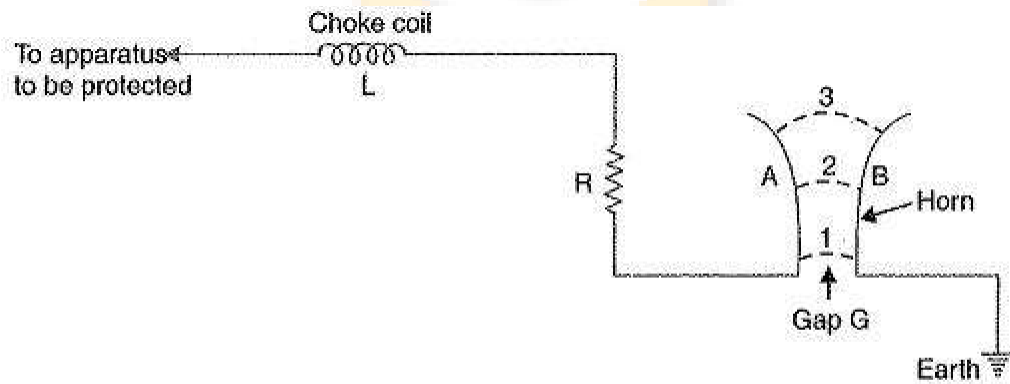

Fig. 24.10

Under normal conditions, the gap is non-conducting i.e. normal supply voltage is insufficient to initiate the arc between the gap. On the occurrence of an overvoltage, spark-over takes place across the small gap G . The heated air around the arc and the magnetic effect of the arc cause the arc to travel up the gap. The arc moves progressively into positions 1, 2 and 3. At some position of the arc (perhaps position 3), the distance may be too great for the voltage to maintain the arc. Consequently, the arc is extinguished. The excess charge on the line is thus, conducted through the arrester to the ground.

Advantages

- The arc is self-clearing. Therefore, this type of arrester does not cause short-circuiting of the system after the Surge Diverter is over as in the case of rod gap.
- Series resistance helps in limiting the follow current to a small value.

Limitations

- The bridging of gap by some external agency (e.g. birds) can render the device useless.
- The setting of horn gap is likely to change due to corrosion or pitting. This adversely affects the performance of the arrester.
- The time of operation is comparatively long, say about 3 seconds. In view of the very short operating time of modern protective gear for feeders, this time is far long.

Due to the above limitations, this type of arrester is not reliable and can only be used as a second line of defense like the rod gap arrester.

3. MULTI GAP ARRESTER:

Fig. 24.11 shows the multigap arrester. It consists of a series of metallic (generally alloy of zinc) cylinders insulated from one another and separated by small intervals of air gaps. The first cylinder (i.e. A) in the series is connected to the line and the other to the ground through a series resistance. The series resistance limits the power arc. By the inclusion of series resistance, the degree of protection against travelling waves is reduced. In order to overcome this difficulty, some of the gaps (B to C in Fig. 24.11) are shunted by a resistance.

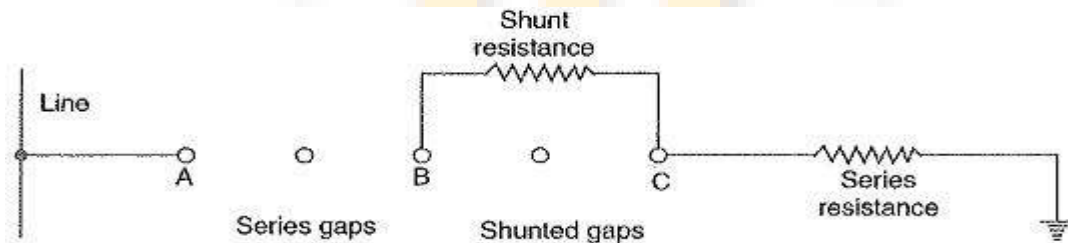

Fig. 24.11

Under normal conditions, the point B is at earth potential and the normal supply voltage is unable to break down the series gaps. On the occurrence of an overvoltage, the breakdown of series gaps A to B occurs. The heavy current after breakdown will choose the straight – through path to earth via the shunted gaps B and C, instead of the alternative path through the shunt resistance. When the surge is over, the arcs B to C go out and any power current following the Surge Diverter is limited by the two resistances (shunt resistance and series resistance) which are now in series. The current is too small to maintain the arcs in the gaps A to B and normal conditions are restored. Such arresters can be employed where system voltage does not exceed 33 kV.

4. EXPULSION TYPE LIGHTNING ARRESTER:

This Expulsion Type Lightning Arrester is also called ‘protector tube’ and is commonly used on system operating at voltages upto 33 kV.

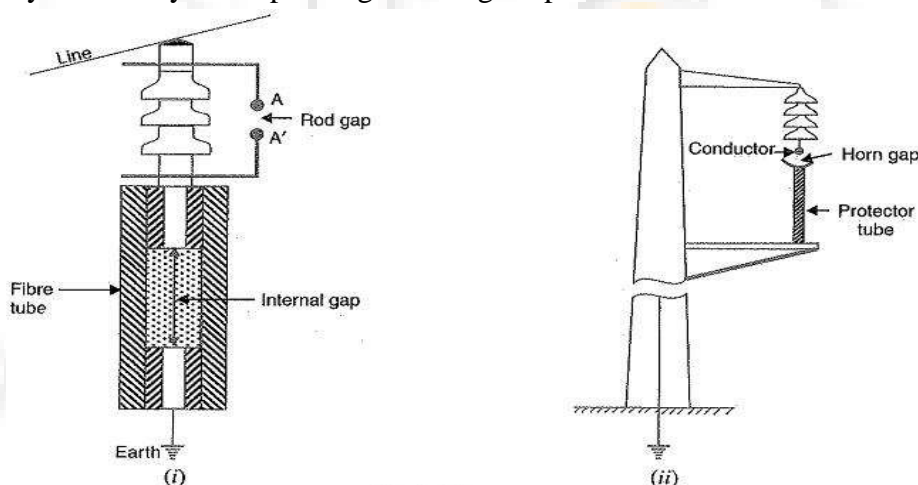

Fig. 24.12

Fig. 24.12 (i) shows the essential parts of an Expulsion Type Lightning Arrester. It essentially consists of a rod gap AA' in series with a second gap enclosed within the fibre tube. The gap in the fibre tube is formed by two electrodes. The upper electrode is connected to rod gap and the lower electrode to the earth. One expulsion arrester is placed under each line conductor. Fig. 24.12 (II) shows the installation of expulsion arrester on an overhead line. On the occurrence of an overvoltage on the line, the series gap AA' is spanned and an arc is struck between the electrodes in the tube. The heat of the arc vaporises some of the fibre of tube walls, resulting in the production of a neutral gas. In an extremely short time, the gas builds up high pressure and is expelled through the lower electrode which is hollow. As the gas leaves the tube violently, it carries away ionised air around the arc. This de-ionising effect is generally so strong that arc goes out at a current zero and will not be re-established.

Advantages

- They are not very expensive.
- They are improved form of rod gap arresters as they block the flow of power frequency follow currents,
- They can be easily installed.

Limitations

- An expulsion type arrester can perform only limited number of operations as during each operation some of the fibre material is used up.
- This type of arrester cannot be mounted in an enclosed equipment due to the discharge of gases during operation.
- Due to the poor volt/amp characteristic of the arrester, is not suitable for the protection of expensive equipment.

5. VALVE TYPE LIGHTNING ARRESTER:

Valve type arresters incorporate non-linear resistors and are extensively used on systems operating at high voltages. Fig. 24.13 (i) shows the various parts of a valve type arrester. It consists of two assemblies (i) series spark gaps and (ii) non-linear resistor discs (made of material such as thyrite or metrosil) in series.

(i) The spark gap is a multiple assembly consisting of a number of identical spark gaps in series. Each gap consists of two electrodes with a fixed gap spacing. The voltage distribution across the gaps is linearised by means of additional resistance elements (called grading resistors) across the gaps. The spacing of the series gaps is such that it will withstand the normal circuit voltage. However, an overvoltage will cause the gap to breakdown, causing the surge current to ground via the non-linear resistors.

(ii) The non-linear resistor discs are made of an inorganic compound such as Thyrite or Metrosil. These discs are connected in series. The non-linear resistors have the property of offering a high resistance to current flow when normal system voltage is applied, but a low resistance to the flow of high-surge currents. In other words, the resistance of these non-linear

elements decreases with the increase in current through them and vice-versa.

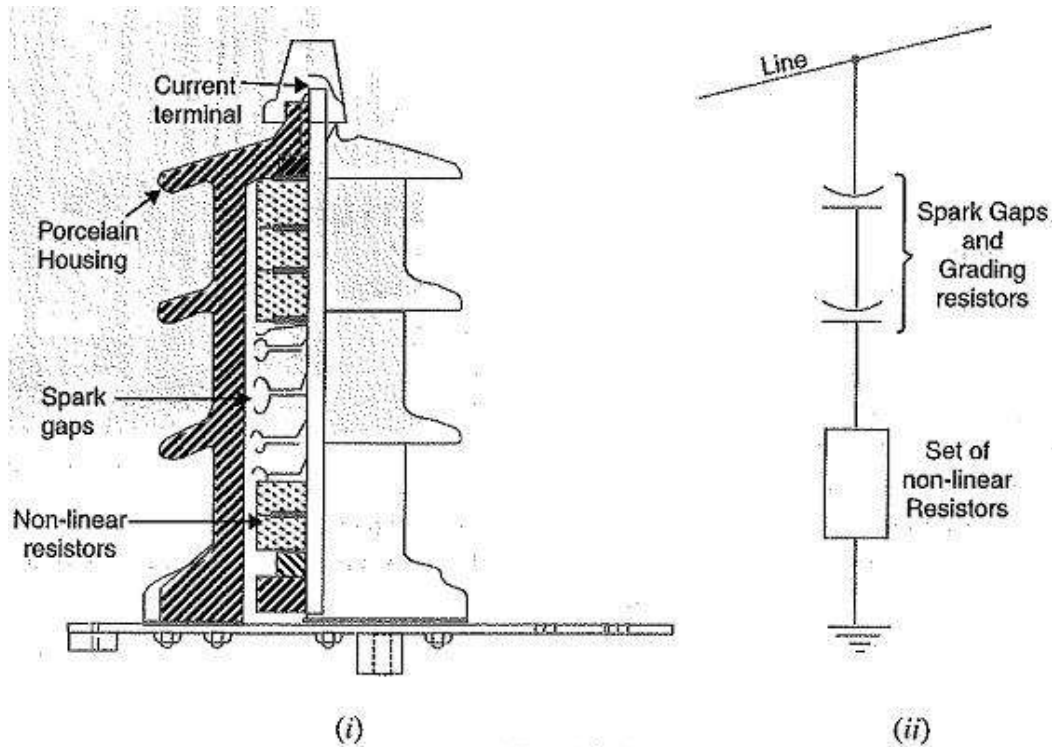

Fig. 24.13

Working: Under normal conditions, the normal system voltage is insufficient to cause the breakdown of air gap assembly. On the occurrence of an overvoltage, the breakdown of the series spark gap takes place and the surge current is conducted to earth via the non-linear resistors. Since the magnitude of surge current is very large, the non-linear elements will offer a very low resistance to the passage of Surge Diverter. The result is that the [surge](#) will rapidly go to earth instead of being sent back over the line. When the surge is over, the non-linear resistors assume high resistance to stop the flow of current.

Advantages

- They provide very effective protection (especially for transformers and cables) against
- They operate very rapidly taking less than a second.
- The impulse ratio is practically unity.

Limitations

- They may fail to check the surges of very steep wave front from reaching the terminal this calls for additional steps to check steep-fronted waves.
- Their performance is adversely affected by the entry of moisture into the enclosure. This necessitates effective sealing of the enclosure at all times.

Applications

According to their application, the valve type arresters are classified as (i) station type and (ii) line type. The station type arresters are generally used for the protection of important equipment in power stations operating on voltages upto 220 kV or higher. The line type arresters are also used for stations handling voltages upto 66 kV