



NARASIMHA REDDY ENGINEERING COLLEGE
UGC - AUTONOMOUS INSTITUTION

COLLEGE CODE: **NRCM**
www.nrcmec.org



ELECTRONIC MEASUREMENTS AND INSTRUMENTATION

Prepared By
Mr. AMGOTH SRINIVAS

UNIT –I

Block Schematics of Measuring Systems

Typical Measurement System Architecture

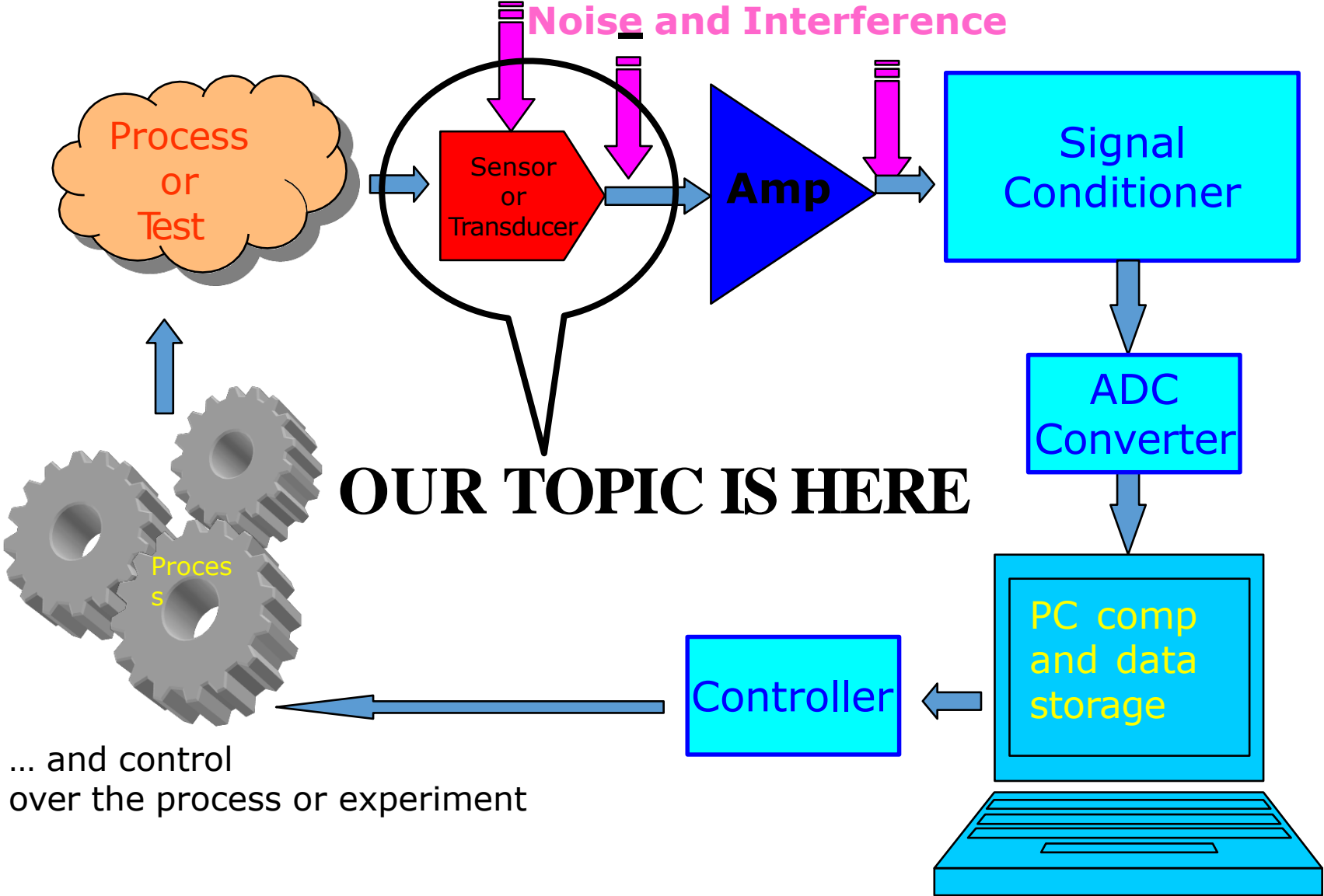

INTRODUCTION

- **Instrumentation** is a technology of measurement which serves sciences, engineering, medicine and etc.
- **Measurement** is the process of determining the amount, degree or capacity by comparison with the accepted standards of the system units being used.
- **Instrument is** a device for determining the value or magnitude of a quantity or variable.
- **Electronic instrument** is based on electrical or electronic principles for its measurement functions.

FUNCTION AND ADVANTAGES

- The 3 basic functions of instrumentation :-
 - Indicating – visualize the process/operation
 - Recording – observe and save the measurement reading
 - Controlling – to control measurement and process
- Advantages of electronic measurement
 - Results high sensitivity rating – the use of amplifier
 - Increase the input impedance – thus lower loading effects
 - Ability to monitor remote signal

PERFORMANCE CHARACTERISTICS

- Performance Characteristics - characteristics that show the performance of an [instrument](#).
 - Eg: accuracy, precision, resolution, sensitivity.
- Allows users to select the most suitable instrument for a specific measuring jobs.
- Two basic characteristics :
 - Static – measuring a constant process condition.
 - Dynamic - measuring a varying process condition.

PERFORMANCE CHARACTERISTICS

- **Accuracy** – the degree of exactness (closeness) of measurement compared to the expected (desired) value.
- **Resolution** – the smallest change in a measurement variable to which an instrument will respond.
- **Precision** – a measure of consistency or repeatability of measurement, i.e successive readings do not differ.
- **Sensitivity** – ratio of change in the output (response) of instrument to a change of input or measured variable.
- **Expected value** – the design value or the most probable value that expect to obtain.
- **Error** – the deviation of the true value from the desired value.

ERROR IN MEASUREMENT

- Measurement always introduce error
- Error may be expressed either as absolute or percentage of error

$$\text{Absolute error, } e = Y_n - X_n$$

where Y_n – expected value

X_n – measured value

$$\% \text{ error} = \left| \frac{Y_n - X_n}{Y_n} \right| \times 100$$

ERROR IN MEASUREMENT

Relative accuracy, $A = 1 - \left| \frac{Y_n - X_n}{Y_n} \right|$

% Accuracy, a = 100% - % error
= $A \times 100$

Precision, P = $1 - \left| \frac{X_n - \overline{X_n}}{\overline{X_n}} \right|$

where X_n - value of the n^{th} measurement

$\overline{X_n}$ - average set of measurement

PRECISION

- The precision of a measurement is a quantitative or numerical indication of the closeness with which a repeated set of measurement of the same variable agree with the average set of measurements.

Example

Given expected voltage value across a resistor is 80V.

The measurement is 79V. Calculate,

- i. The absolute error
- ii. The % of error
- iii. The relative accuracy
- iv. The % of accuracy

Solution (Example 1.1)

Given that , expected value = 80V
measurement value = 79V

i. Absolute error, $e = Y_n - X_n = 80V - 79V = 1V$

ii. % error = $\left| \frac{Y_n - X_n}{Y_n} \right| \times 100 = \frac{80 - 79}{80} \times 100 = 1.25\%$

iii. Relative accuracy, $A = 1 - \left| \frac{Y_n - X_n}{Y_n} \right| = 0.9875$

iv. % accuracy, $a = A \times 100\% = 0.9875 \times 100\% = 98.75\%$

Example 1.2

From the value in table 1.1 calculate the precision of 6th measurement?

Solution

the average of measurement value

$$\bar{X}_n = \frac{98+101+\dots+99}{10} = \frac{1005}{10} = 100.5$$

the 6th reading

$$\text{Precision} = 1 - \left| \frac{100 - 100.5}{100.5} \right| = 1 - \frac{0.5}{100.5} = 0.995$$

Table 1.1

No	X _n
1	98
2	101
3	102
4	97
5	101
6	100
7	103
8	98
9	106
10	99

LIMITING ERROR

- The accuracy of measuring instrument is guaranteed within a certain percentage (%) of full scale reading
- E.g manufacturer may specify the instrument to be accurate at $\pm 2\%$ with full scale deflection
- For reading less than full scale, the limiting error increases

LIMITING ERROR (cont)

Example 1.6

Given a 600 V voltmeter with accuracy $\pm 2\%$ full scale.

Calculate limiting error when the instrument is used to measure a voltage of 250V?

Solution

The magnitude of limiting error, $0.02 \times 600 = 12\text{V}$

Therefore, the limiting error for 250V = $12/250 \times 100 = 4.8\%$

LIMITING ERROR (cont)

Example 1.7

Given for certain measurement, a limiting error for voltmeter at 70V is 2.143% and a limiting error for ammeter at 80mA is 2.813%. Determine the limiting error of the power.

Solution

$$\begin{aligned}\text{The limiting error for the power} &= 2.143\% + 2.813\% \\ &= \underline{4.956\%}\end{aligned}$$

Exercise

- A voltmeter is accurate 98% of its full scale reading.
 - i. If the voltmeter reads 200V on 500V range, what is the absolute error?
 - ii. What is the percentage error of the reading in (i).

Significant Figures

- Significant figures convey actual information regarding the magnitude and precision of quantity
- More significant figure represent greater precision of measurement

Example 1.3

Find the precision value of X_1 and X_2 ?

$$X_n = 101$$

$$X_1 = 98 \implies 2 \text{ s.f.}$$

$$X_2 = 98.5 \implies 3 \text{ s.f.}$$

Solution (Example 1.3)

$$\overline{X}_n = 101$$

$$X_1 = 98 \implies 2 \text{ s.f.}$$

$$X_2 = 98.5 \implies 3 \text{ s.f.}$$

$$X_1 \text{ Precision} = 1 - \left| \frac{98 - 101}{101} \right| = 0.97$$

$$X_2 \text{ Precision} = 1 - \left| \frac{98.5 - 101}{101} \right| = 0.975 \implies \text{more precise}$$

TYPES OF STATIC ERROR

- Types of static error
 - 1) Gross error/human error
 - 2) Systematic Error
 - 3) Random Error

TYPES OF STATIC ERROR

1) **Gross Error**

- ❖ cause by human mistakes in reading/using instruments
- ❖ may also occur due to incorrect adjustment of the instrument and the computational mistakes
- ❖ cannot be treated mathematically
- ❖ cannot eliminate but can minimize
- ❖ Eg: Improper use of an instrument.
- ❖ This error can be minimized by taking proper care in reading and recording measurement parameter.
- ❖ In general, indicating instruments change **ambient conditions** to some extent when connected into a complete circuit.
- ❖ Therefore, several readings (at **three** readings) must be taken to minimize the effect of ambient condition changes.

TYPES OF STATIC ERROR (cont)

2) Systematic Error

- due to shortcomings of the instrument (such as defective or worn parts, ageing or effects of the environment on the instrument)
- In general, systematic errors can be subdivided into static and dynamic errors.
 - Static – caused by **limitations** of the measuring device or the physical laws governing its behavior.
 - Dynamic – caused by the instrument **not responding very fast** enough to follow the changes in a measured variable.

TYPES OF STATIC ERROR (cont)

3 types of systematic error :-

- (i) Instrumental error
- (ii) Environmental error
- (iii) Observational error

TYPES OF STATIC ERROR (cont)

(i) Instrumental error

Inherent while measuring instrument because of their mechanical structure (eg: in a D'Arsonval meter, friction in the bearings of various moving component, irregular spring tension, stretching of spring, etc)

Error can be avoid by:

- (a) selecting a suitable instrument for the particular measurement application
- (b) apply correction factor by determining instrumental error
- (c) calibrate the instrument against standard

TYPES OF STATIC ERROR (cont)

- (ii) Environmental error
 - due to external condition effecting the measurement including surrounding area condition such as change in temperature, humidity, barometer pressure, etc
 - to avoid the error :-
 - (a) use air conditioner
 - (b) sealing certain component in the instruments
 - (c) use magnetic shields

- (iii) Observational error
 - introduce by the observer
 - most common : parallax error and estimation error (while reading the scale)
 - Eg: an observer who tend to hold his head too far to the left while reading the position of the needle on the scale.

TYPES OF STATIC ERROR (cont)

3) Random error

- due to unknown causes, occur when all systematic error has accounted
- accumulation of small effect, require at high degree of accuracy
- can be avoid by
 - (a) increasing number of reading
 - (b) use statistical means to obtain best approximation of true value

Dynamic Characteristics

- Dynamic – measuring a varying process condition.
- Instruments rarely respond instantaneously to changes in the measured variables due to such things as mass, thermal capacitance, fluid capacitance or electrical capacitance.
- Pure delay in time is often encountered where the instrument waits for some reaction to take place.
- Such industrial instruments are nearly always used for measuring quantities that fluctuate with time.
- Therefore, the dynamic and transient behavior of the instrument is important.

Dynamic Characteristics

- The dynamic behavior of an instrument is determined by subjecting its primary element (sensing element) to some **unknown** and predetermined variations in the measured quantity.
- The three most common variations in the measured quantity:
 - Step change
 - Linear change
 - Sinusoidal change

Dynamic Characteristics

- **Step change**-in which the primary element is **subjected to an instantaneous and finite change** in measured variable.
- **Linear change**-in which the primary element is following the measured variable, **changing linearly with time**.
- **Sinusoidal change**-in which the primary element follows a measured variable, the magnitude of which **changes in accordance with a sinusoidal function of constant amplitude**.

The **rapidity** with which an instrument responds changes in measured quantity.

- Dynamic error-The **difference between the true and measured value** with no static error.
- Lag – **delay** in the response of an instrument to changes in the measured variable.
- Fidelity – the degree to which an instrument **indicates the changes** in the measured variable without dynamic error (faithful reproduction).

ELECTRONIC INSTRUMENT

- Basic elements of an electronics instrument



1) Transducer

- convert a non electrical signal into an electrical signal
- e.g: a pressure sensor detect pressure and convert it to electricity for display at a remote gauge.

2) Signal modifier

- convert input signal into a suitable signal for the indicating device

3) Indicating device

- indicates the value of quantity being measure

INSTRUMENT APPLICATION GUIDE

- Selection, care and use of the instrument :-
 - ✓ Before using an instrument, students should be thoroughly familiar with its operation ** read the manual carefully
 - ✓ Select an instrument to provide the degree of accuracy required (accuracy + resolution + cost)
 - ✓ Before used any selected instrument, do the inspection for any physical problem
 - ✓ Before connecting the instrument to the circuit, make sure the _function switch‘ and the _range selector switch‘ has been set-up at the proper function or range

INSTRUMENT APPLICATION GUIDE



Analog Multimeter

INSTRUMENT APPLICATION GUIDE



Digital Multimeter

DC AND AC METER

D'ARSONVAL METER MOVEMENT

- Also called Permanent-Magnet Moving Coil (PMMC).
- Based on the moving-coil galvanometer constructed by Jacques d' Arsonval in 1881.
- Can be used to indicate the value of DC and AC quantity.
- Basic construction of modern PMMC can be seen in Figure .

Operation of D'Arsonval Meter

- When current flows through the coil, the core will rotate.
- Amount of rotation is proportional to the amount of current flows through the coil.
- The meter requires low current ($\sim 50\mu\text{A}$) for a full scale deflection, thus consumes very low power (25-200 μw).
- Its accuracy is about 2% -5% of full scale deflection

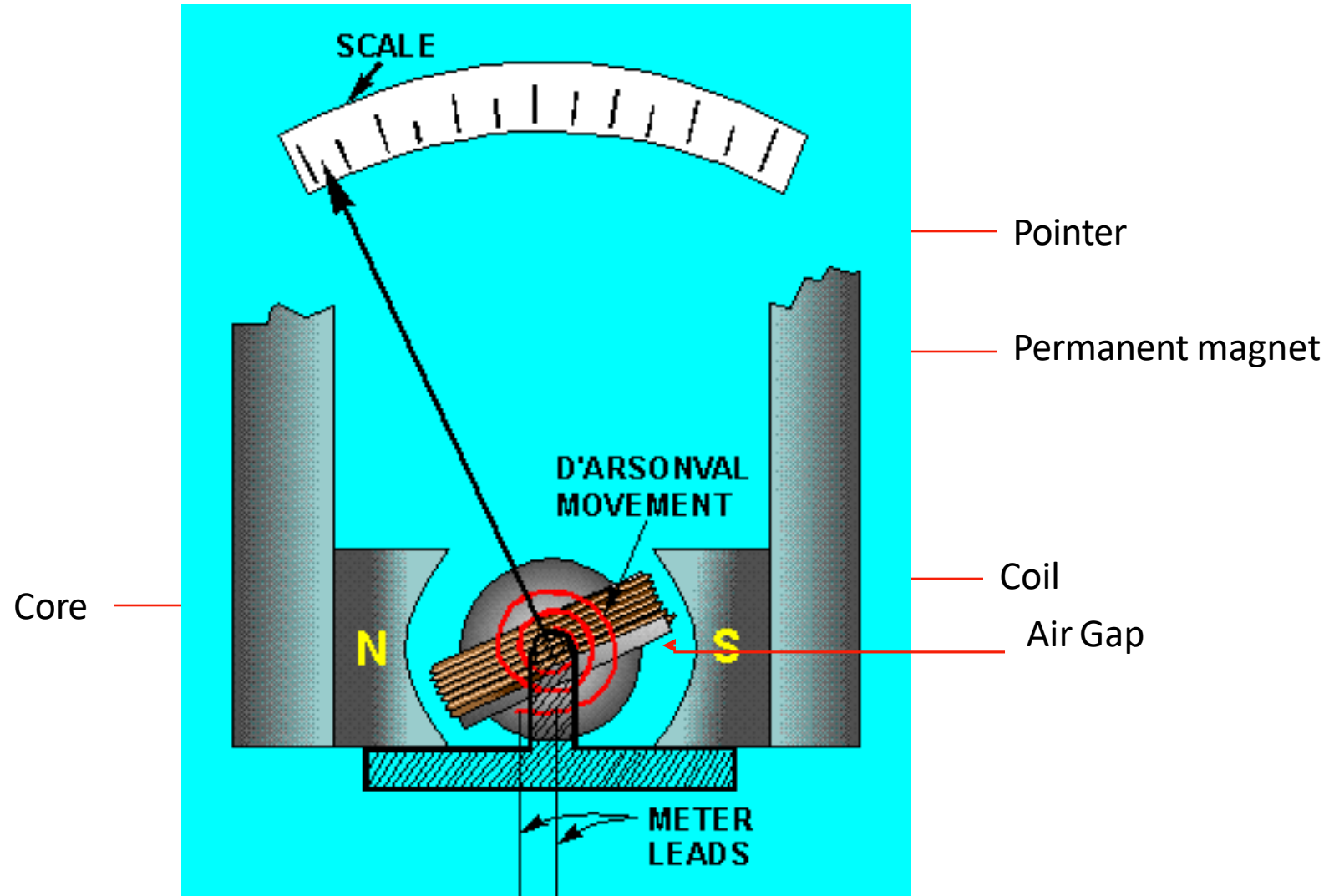

Fig: Modern D'Arsonval Movement

DC AMMETER

- The PMMC galvanometer constitutes the basic movement of a dc ammeter.
- The coil winding of a basic movement is small and light, so it can carry only very small currents.
- A low value resistor (shunt resistor) is used in DC ammeter to measure large current.
- Basic DC ammeter:

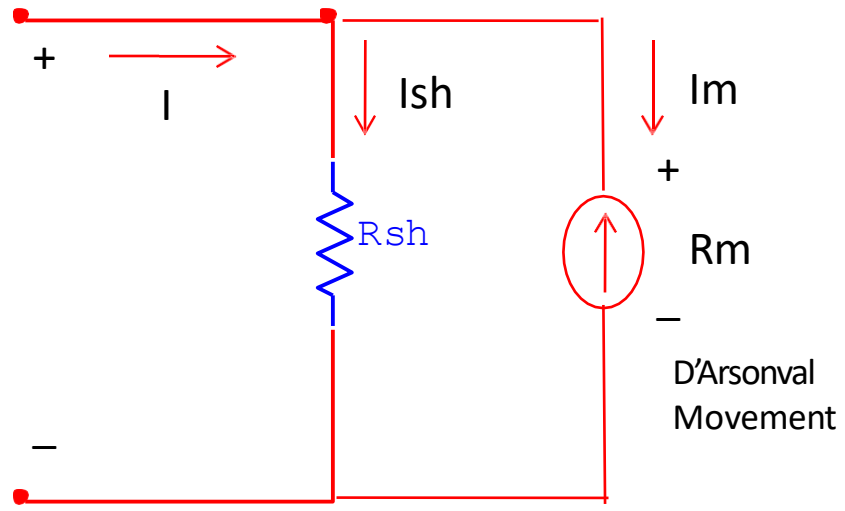

Figure : Basic DC Ammeter

- Referring to Fig.

R_m = internal resistance of the movement

R_{sh} = shunt resistance

I_{sh} = shunt current

I_m = full scale deflection current of the movement

I = full scale current of the ammeter + shunt (i.e. total current)

$$I_{sh} R_{sh} = I_m R_m$$

$$I_{sh} = I - I_m$$

$$R_{sh} = \frac{I_m R_m}{I - I_m}$$

EXAMPLE

- A 1mA meter movement with an internal resistance of 100Ω is to be converted into a 0-100 mA. Calculate the value of shunt resistance required. (ans: 1.01Ω)

MULTIRANGE AMMETER

- ❖ The range of the dc ammeter is extended by a number of shunts, selected by a range switch.
- ❖ The resistors is placed in parallel to give different current ranges
- ❖ Switch S (multi-position switch) protects the meter movement from being damage during range changing.

Increase cost of the meter.

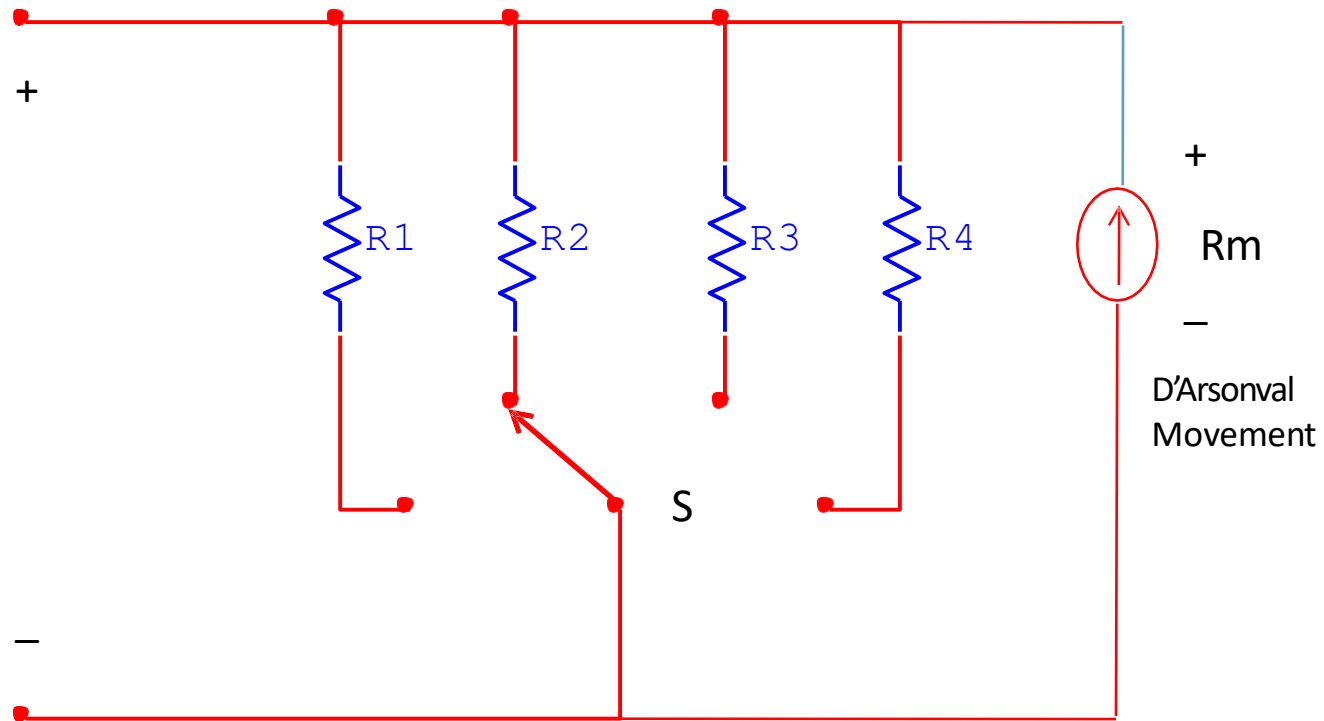

Figure : Multirange Ammeter

Aryton shunt or universal shunt

- ❖ Aryton shunt eliminates the possibility of having the meter in the circuit without a shunt.

- ❖ Reduce cost

- ❖ Position of the switch:

- a)'1': R_a parallel with series combination of R_b , R_c and the meter movement.

- Current through the shunt is more than the current through the meter movement, thereby protecting the meter movement and reducing its sensitivity.

- b)'2': R_a and R_b in parallel with the series combination of R_c and the meter movement. The current through the meter is more than the current through the shunt resistance.

- c)'3': R_a , R_b and R_c in parallel with the meter. Maximum current flows through the meter movement and very little through the shunt. This will increase the sensitivity.

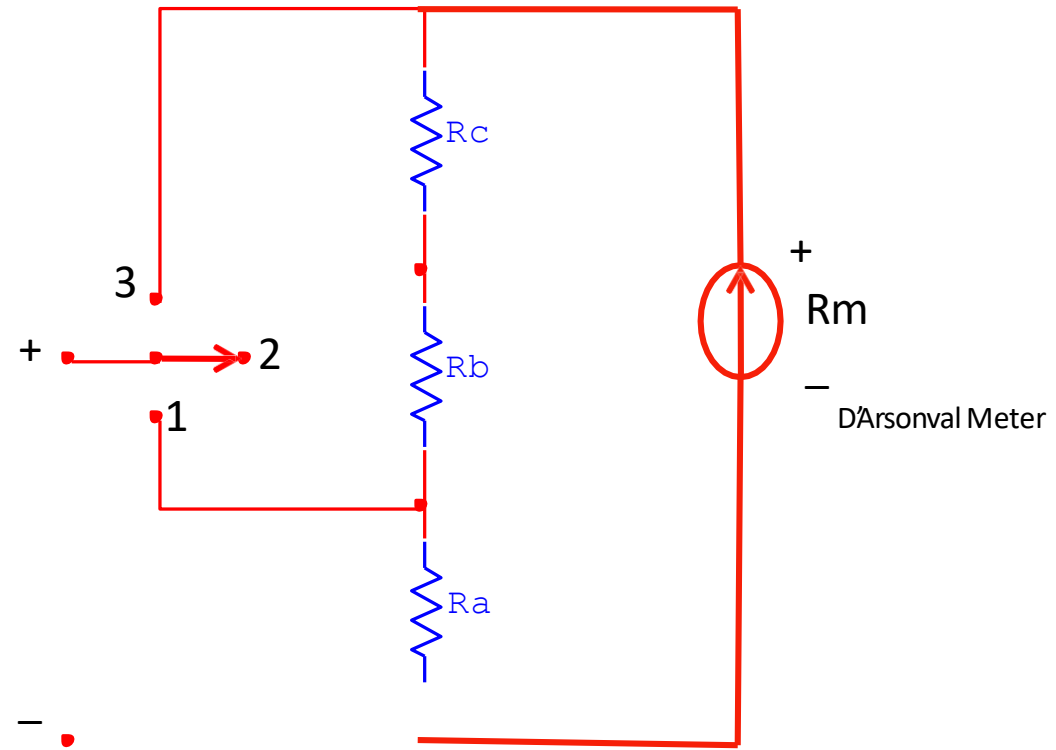
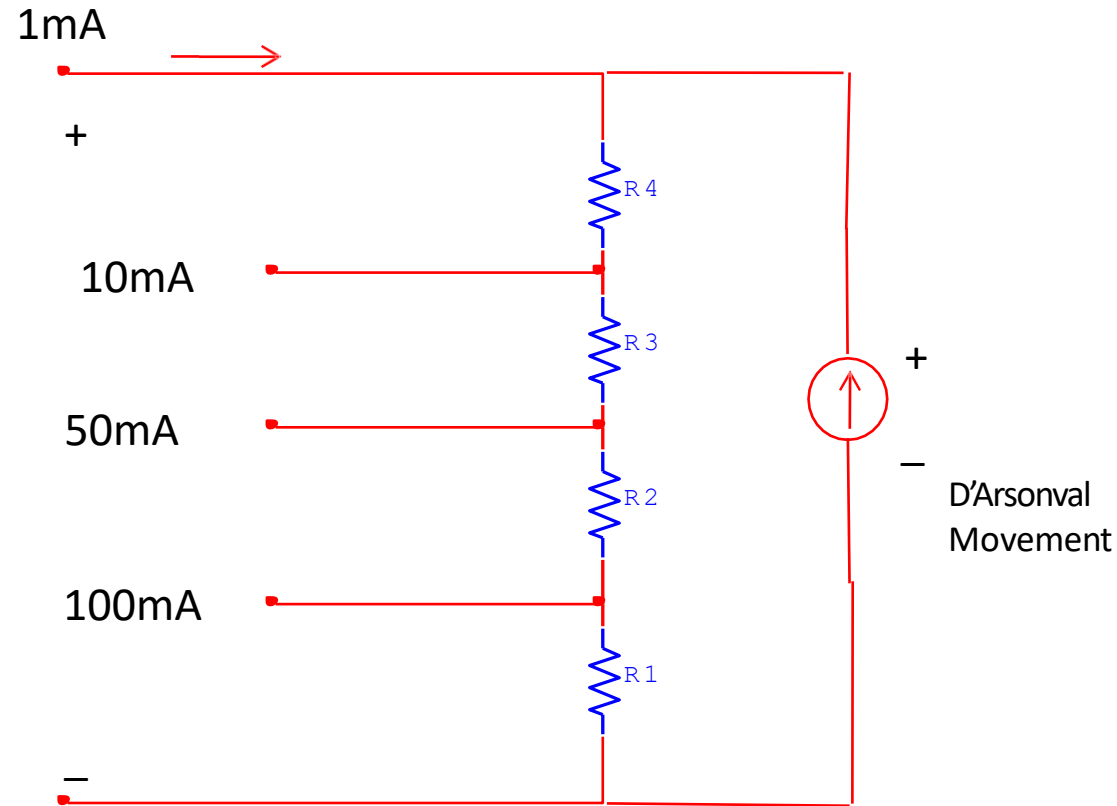

Figure : Ayrton

Shunt

EXAMPLE

- Design an Aryton shunt to provide an ammeter with a current range of 0-1 mA, 10 mA, 50 mA and 100 mA. AD' Arsonval movement with an internal resistance of 100Ω and full scale current of $50\mu\text{A}$ is used.



REQUIREMENT OF A SHUNT

1) **Minimum Thermal Dielectric Voltage Drop**

Soldering of joint should not cause a voltage drop.

2) **Solderability**

- never connect an ammeter across a source of e.m.f

- observe the correct polarity

- when using the multirange meter, first use the highest current range.

BASIC METER AS ADC VOLTMETER

- To use the basic meter as a dc voltmeter, must know the amount of current (I_{fsd}) required to deflect the basic meter to full scale.
- The sensitivity is based on the fact that the full scale current should result whenever a certain amount of resistance is present in the meter circuit for each voltage applied.

$$S = \frac{1}{I_{fsd}}$$

EXAMPLE

Calculate the sensitivity of a 200 μA meter movement which is to be used as a dc voltmeter.

Solution:

$$S = \frac{1}{I_{fsd}} = \frac{1}{200\mu\text{A}} = 5\text{k}\Omega/\text{V}$$

DC VOLTMETER

□ A basic D'Arsonval movement can be converted into a DC voltmeter by adding a series resistor (multiplier) as shown in Figure.

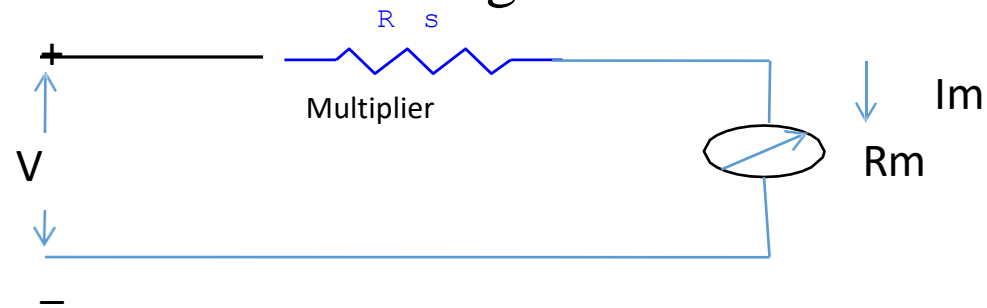

Figure : Basic DC Voltmeter

I_m =full scale deflection current of the movement (I_{fsd})

R_m =internal resistance of the movement

R_s =multiplier resistance

V =full range voltage of the instrument

- From the circuit of Figure

$$V = I_m (R_s + R_m)$$

$$R_s = \frac{V - I_m R_m}{I_m} = \frac{V}{I_m} - R_m$$

$$R_s = \frac{V}{I_m} - R_m$$

EXAMPLE

A basic D' Arsonval movement with a full-scale deflection of 50 μA and internal resistance of 500Ω is used as a DC voltmeter. Determine the value of the multiplier resistance needed to measure a voltage range of 0-10V.

Solution:

$$R_s = \frac{V_m}{I_m} - R_m = \frac{10\text{V}}{50\mu\text{A}} - 500\Omega = 199.5\text{k}\Omega$$

- Sensitivity and voltmeter range can be used to calculate the multiplier resistance, R_s of a DC voltmeter.

$$R_s = (S \times \text{Range}) - R_m$$

- From example 2.4:

$$I_m = 50\mu\text{A}, R_m = 500\Omega, \text{Range} = 10\text{V}$$

Sensitivity,

$$S = \frac{1}{I_m} = \frac{1}{50\mu\text{A}} = 20\text{k}\Omega/\text{V}$$

$$\begin{aligned} \text{So, } R_s &= (20\text{k}\Omega/\text{V} \times 10\text{V}) - 500\Omega \\ &= 199.5\text{ k}\Omega \end{aligned}$$

MULTI-RANGE VOLTMETER

- DC voltmeter can be converted into a multi-range voltmeter by connecting a number of resistors (multipliers) in series with the meter movement.
- A practical multi-range DC voltmeter is shown in Figure

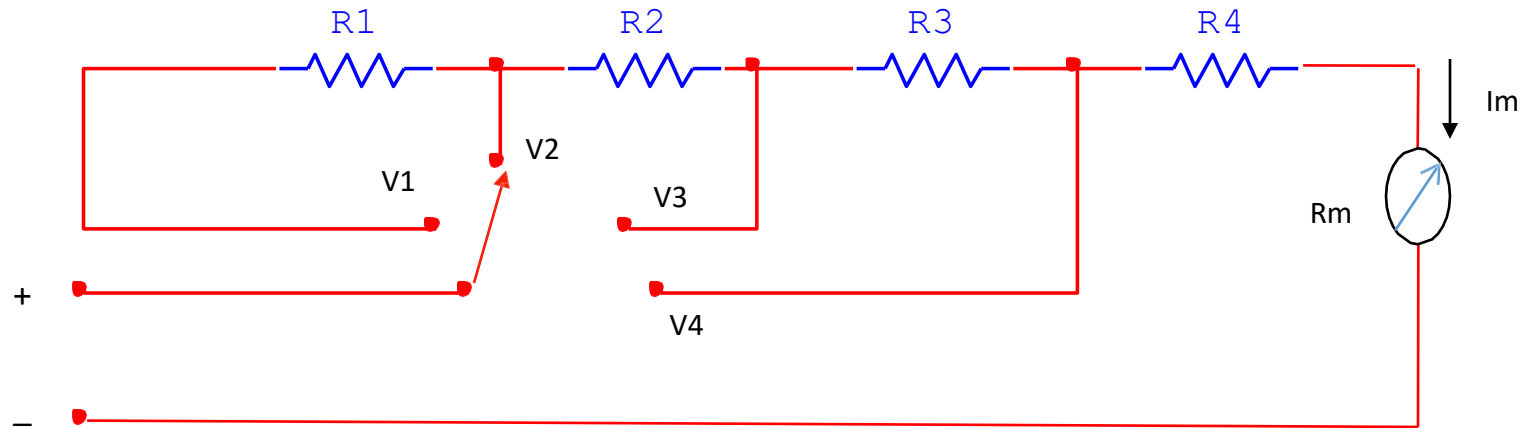

Figure: Multirange voltmeter

EXAMPLE

Convert a basic D'Arsonval movement with an internal resistance of 50Ω and a full scale deflection current of 2 mA into a multirange dc voltmeter with voltage ranges of 0-10V, 0-50V, 0-100V and 0-250V.

VOLTMETER LOADING EFFECTS

- When a voltmeter is used to measure the voltage across a circuit component, the voltmeter circuit itself is in parallel with the circuit component.
- Total resistance will decrease, so the voltage across component will also decrease. This is called voltmeter loading.
- The resulting error is called a loading error.
- The voltmeter loading can be reduced by using a high sensitivity voltmeter.
- How about ammeter??

AMMETER INSERTION EFFECTS

- Inserting Ammeter in a circuit always increases the resistance of the circuit and, thus always reduces the current in the circuit. The expected current:

$$I_e = \frac{E}{R_1}$$

- Placing the meter in series with R1 causes the current to reduce to a value equal to:

$$I_m = \frac{E}{R_1 + R_m}$$

AMMETER INSERTION EFFECTS

- Dividing equation 1 by 2 yields:

$$\frac{I_m}{I_e} = \frac{R_1}{R_1 + R_m}$$

- The Ammeter insertion error is given by :

Insertion Error

$$= \left(1 - \frac{I_m}{I_e} \right) \times 100\%$$

OHMMETER (Series Type)

- Current flowing through meter movements depends on the magnitude of the unknown resistance.
- The meter deflection is non-linearly related to the value of the unknown Resistance, R_x .
- A major drawback – as the internal voltage decreases, reduces the current and meter will not get zero Ohm.
- R_2 counteracts the voltage drop to achieve zero ohm. How do you get zero Ohm?
- R_1 and R_2 are determined by the value of $R_x = R_h$ where $R_h =$ half of full scale deflection resistance.

$$R_h = R_1 + (R_2 // R_m) = R_1 + \frac{R_2 R_m}{R_2 + R_m}$$

- The total current of the circuit, $I_t = V/R_h$
- The shunt current through R_2 is $I_2 = I_t - I_{fsd}$

OHMMETER (Series Type)

- The voltage across the shunt, $V_{sh} = V_m$

So, $I_2 R_2 = I_{fsd} R_m$

Since $I_2 = I_t - I_{fsd}$

Then,
$$R_2 = \frac{I_{fsd} R_m}{I_t - I_{fsd}}$$

Since $I_t = V/R_h$

So,
$$R_2 = \frac{I_{fsd} R_m R_h}{V - I_{fsd} R_h}$$

$$R_1 = R_h - \frac{I_{fsd} R_m R_h}{V}$$

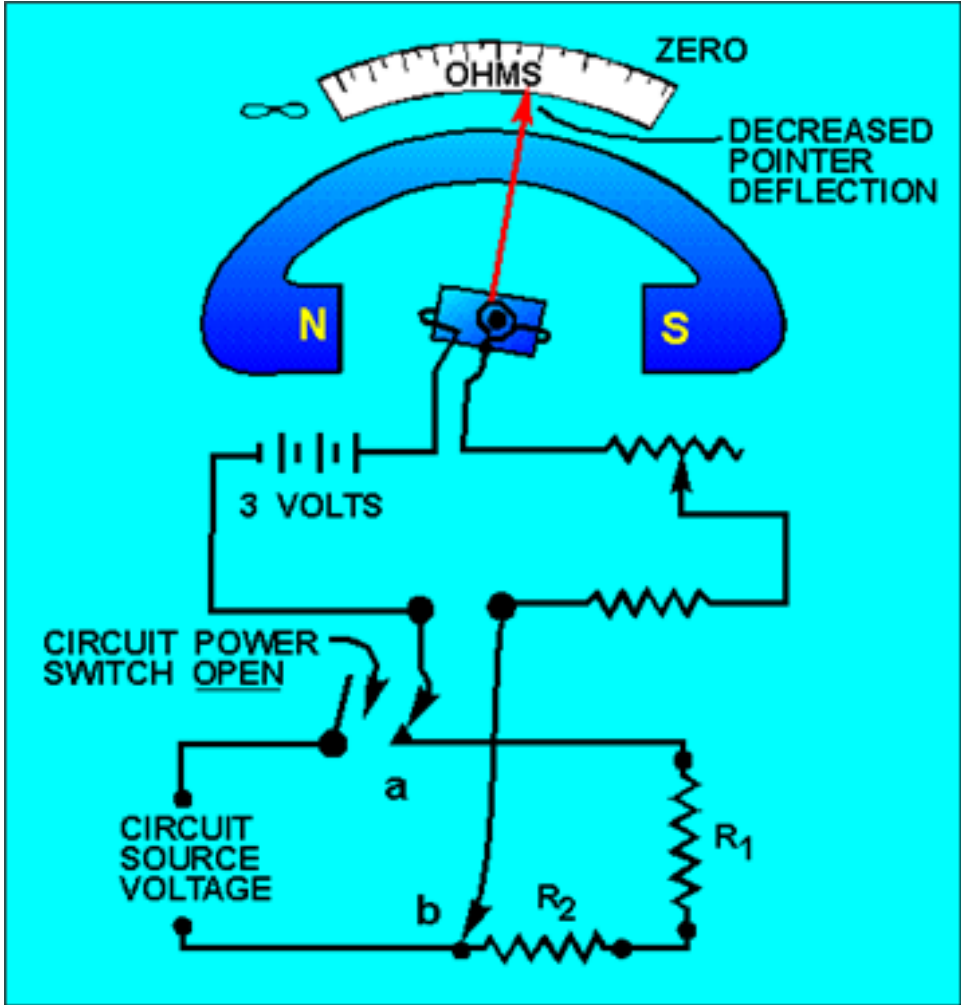

Figure : Measuring circuit resistance with an ohmmeter

Example:

- 1) A $50\mu\text{A}$ full scale deflection current meter movement is to be used in an Ohmmeter. The meter movement has an internal resistance $R_m = 2\text{k}\Omega$ and a 1.5V battery is used in the circuit. Determine R_z at full scale deflection.
- 2) A 100Ω basic movement is to be used as an ohmmeter requiring a full scale deflection of 1mA and internal battery voltage of 3V . A half scale deflection marking of 2k is desired. Calculate:
 - i. value of R_1 and R_2
 - ii. the maximum value of R_2 to compensate for a 5% drop in battery voltage

MULTIMETER

- Multimeter consists of an ammeter, voltmeter and ohmmeter in one unit.
- It has a function switch to connect the appropriate circuit to the D'Arsonval movement.
- Fig.4.33 (in text book) shows DC milliammeter, DC voltmeter, AC voltmeter, microammeter and ohmmeter.

AC VOLTMETER USING HALF-WAVE RECTIFIER

- The D'Arsonval meter movement can be used to measure alternating current by the use of a diode rectifier to produce unidirectional current flow.
- In case of a half wave rectifier, if given input voltage, $E_{in} = 10 V_{rms}$, then:

Peak voltage,

$$E_p = 10V_{rms} \times 1.414 = 14.14V$$

Average voltage,

$$E_{ave} = E_{dc} = 0.636 \times E_p = 8.99V$$

- o Since the diode conducts only during the positive half cycle as shown in Fig 4.18(in text book), the average voltage is given by:

$$E_{ave} / 2 = 4.5V$$

AC VOLTMETER USING HALF-WAVE RECTIFIER

- Therefore, the pointer will deflect for a full scale if 10 Vdc is applied and only 4.5 V when a 10 Vrms sinusoidal signal is applied.
- The DC voltmeter sensitivity is given by:

$$S_{dc} = \frac{1}{I_m} = \frac{1}{1mA} = 1k\Omega/V$$

- For the circuit in Figure 4.18, the AC voltmeter sensitivity is given by:

$$S_{ac} = 0.45S_{dc} = 0.45k\Omega/V$$

- This means that an AC voltmeter is not as sensitive as a DC voltmeter.

AC VOLTMETER USING HALF-WAVE RECTIFIER

- To get the multiplier resistor, R_s value:

$$E_{dc} = 0.45 \times E_{rms}$$

$$R_s = \frac{E_{dc}}{I_{dc}} - R_m = \frac{0.45 \times E_{rms}}{I_{dc}} - R_m$$

o The AC meter scale is usually calibrated to give the RMS value of an alternating sine wave input.

- A more general AC voltmeter circuit is shown in Fig. 4.17 (in text book)
- A shunt resistor, R_{sh} is used to draw more current from the diode D1 to move its operating point to a linear region.
- Diode D2 is used to conduct the current during the negative half cycle.
- The sensitivity of AC voltmeter can be doubled by using a full wave rectifier.

Important statistical definitions

➤ *Deviation*

$$d_n \equiv X_n - \langle X \rangle$$

➤ *Average deviation*

$$D_N \equiv \frac{\sum_{n=1}^N X_n - \langle X \rangle}{N}$$

➤ *Standard deviation*

$$S_N \equiv \sqrt{\frac{1}{N} \sum_{n=1}^N (X_n - \langle X \rangle)^2} = \sigma_X$$

➤ *Signal-to-noise Ratio*

$$SNR \equiv \frac{\langle X \rangle}{\sigma_X} = \frac{\langle X \rangle}{\sqrt{\frac{1}{N} \sum_{n=1}^N (X_n - \langle X \rangle)^2}} \propto \sqrt{N}$$

SNR improves as

$$SNR \equiv \frac{\langle X \rangle}{\sigma_X} \propto \sqrt{N}$$

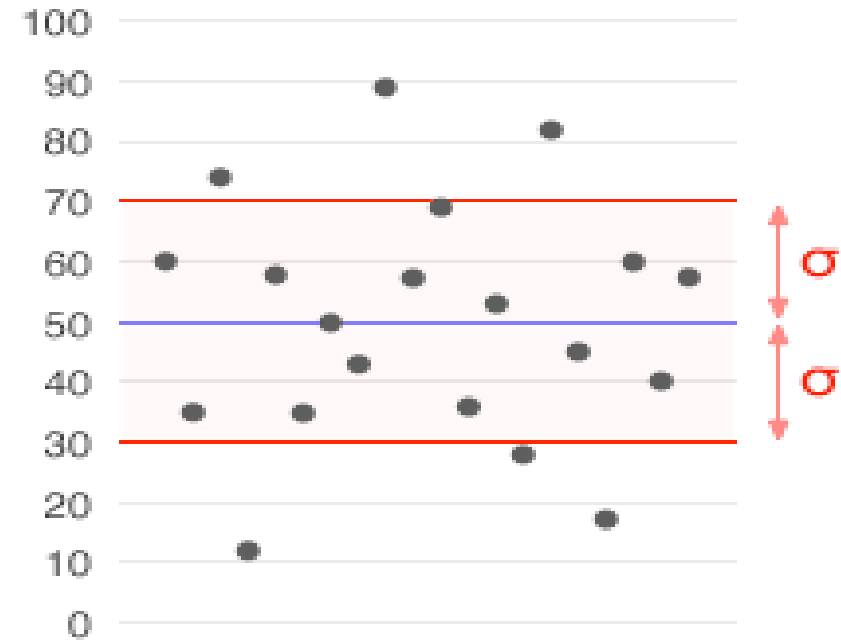

Sensitivity, Span, Precision

- *Sensitivity* is a parameter extracted from the instrument response (based on the assumption that the response is linear). If *input quantity* changes by ΔQ_{INP} , resulting in the *output quantity* change of ΔQ_{OUT} , then the sensitivity is

$$S = \frac{\Delta Q_{out}}{\Delta Q_{inp}}$$

- *Span* of the Instrument is the difference between the upper and the lower limits of operation

$$\text{span} = \text{Upper} - \text{Lower}$$

- *Precision Measurement* requires a measurement system capable of resolving very small signals, (say, one part in 10^7). In other words, the precise measurement is such for which

$$\text{Span} / \text{Resolution} \gg 1$$

Signal Analyzers

UNIT-II

INTRODUCTION

- In the CRO we discussed measurement techniques in the time domain, that is, measurement of parameters that vary with time. Electrical signals contain a great deal of interesting and valuable information in the frequency domain as well. Analysis of signals in the frequency domain is called spectrum analysis, which is defined as the study of the distribution of a signal's energy as a function of frequency.

INTRODUCTION

- This analysis provides both electrical and physical system information which is very useful in performance testing of both mechanical and electrical systems. This chapter discusses the basic theory and applications of the principal instruments used for frequency domain analysis: distortion analyzers, wave analyzers, spectrum analyzers, and Fourier analyzers
- Each of these instruments quantifies the magnitude of the signal of interest through a specific bandwidth, but each measurement technique is different as will be seen in the discussion that follows.

DISTORTION ANALYZERS

- When an amplifier is not operating in a linear fashion, the output signal will be distorted. Distortion caused by nonlinear operation is called amplitude distortion or harmonic distortion. It can be shown mathematically that an amplitude-distorted sine wave is made up of pure sine-wave components including the fundamental frequency f of the input signal and harmonic multiples of the fundamental frequency, $2f$, $3f$, $4f \dots$, and so on.

DISTORTION ANALYZERS

- When harmonics are present in considerable amount, their presence can be observed with an oscilloscope. The waveform displayed will either have unequal positive and negative peak values or will exhibit a change in shape. In either case, the oscilloscope will provide a qualitative check of harmonic distortion. However, the distortion must be fairly severe (around 10%) to be noted by an untrained observer.

DISTORTION ANALYZERS

- In addition, most testing situations require a better quantitative measure of harmonic distortion. Harmonic distortion can be quantitatively measured very accurately with a harmonic distortion analyzer, which is generally referred to simply as a distortion analyzer.

DISTORTION ANALYZERS

- A block diagram for a fundamental-suppression harmonic analyzer is shown in Fig. 1. When the instrument is used, switch S_1 is set to the "set level" position, the band pass filter is adjusted to the fundamental frequency and the attenuator network is adjusted to obtain a full-scale voltmeter reading.

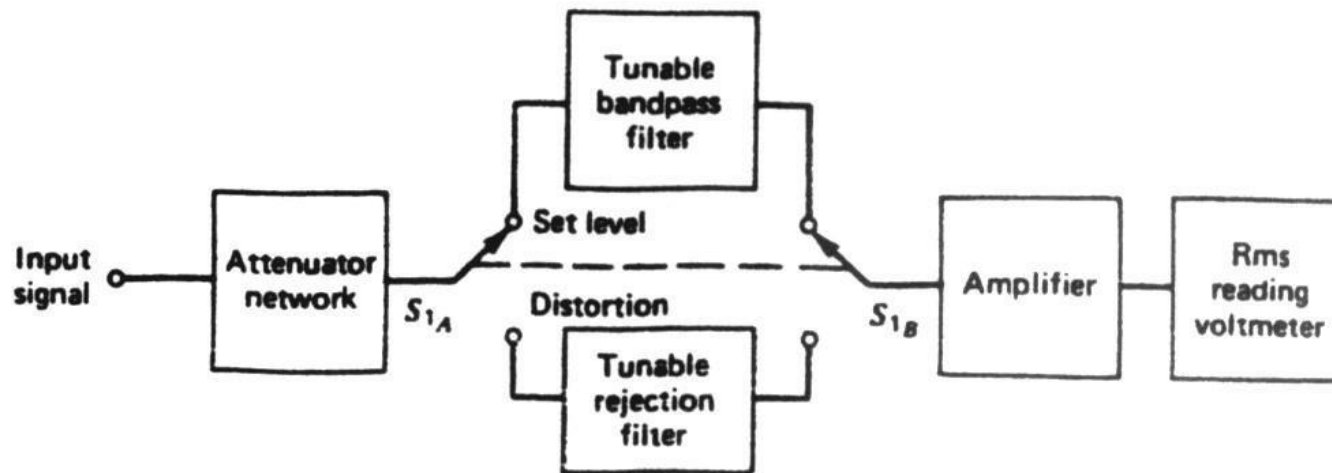

Fig. 1 Block diagram of a distortion analyzer.

DISTORTION ANALYZERS

- Switch S, is then set to the "distortion" position, the rejection filter is turned to the fundamental frequency, and the attenuator is adjusted for a maximum reading on the voltmeter.
- The total harmonic distortion (THD), which is frequently expressed as a percentage, is defined as the ratio of the rms value of all the harmonics to the rms value of the fundamental,

or

$$THD = \frac{\sqrt{\Sigma(\text{harmonics})^2}}{\text{fundamental}}$$

DISTORTION ANALYZERS

- This defining equation is somewhat inconvenient from the standpoint of measurement. An alternative working equation expresses total harmonic distortion as the ratio of the rms value of all the harmonics to the rms value of the total signal including distortion. That is,

$$THD = \frac{\sqrt{\Sigma(\text{harmonics})^2}}{\sqrt{(\text{fundamental})^2 + \Sigma(\text{harmonics})^2}} \quad (2)$$

DISTORTION ANALYZERS

- On the basis of the assumption that any distortion caused by the components within the analyzer itself or by the oscillator signal are small enough to be neglected. Eq. 2 can be expressed as

$$THD = \frac{\sqrt{E_2^2 + E_3^2 + \dots + E_n^2}}{E_f} \quad (3)$$

where

THD = the total harmonic distortion

E_f = the amplitude of the fundamental frequency including the harmonics

$E_2 E_3 E_n$ = the amplitude of the individual harmonics

THD = E(harmonics) / fundamental

DISTORTION ANALYZERS

- **EXAMPLE 1:**

Compute the total harmonic distortion of a signal that contains a fundamental signal with an rms value of 10 V, a second harmonic with an rms value of 3 V, a third harmonic with an rms value of 1.5 V, and a fourth harmonic with an rms value of 0.6 V.

SOLUTION:

$$\begin{aligned} THD &= \frac{\sqrt{3^2 + 1.5^2 + 0.6^2}}{10} \\ &= \frac{\sqrt{11.6}}{10} = 34.07\% \end{aligned}$$

DISTORTION ANALYZERS

A typical laboratory-quality distortion analyzer is shown in Fig. 2. The instrument shown, a Hewlett-Packard Model [334A](#), is capable of measuring total distortion as small as 0.1% of full scale at any frequency between 5 Hz and 600 kHz. Harmonics up to 3 MHz can be measured.

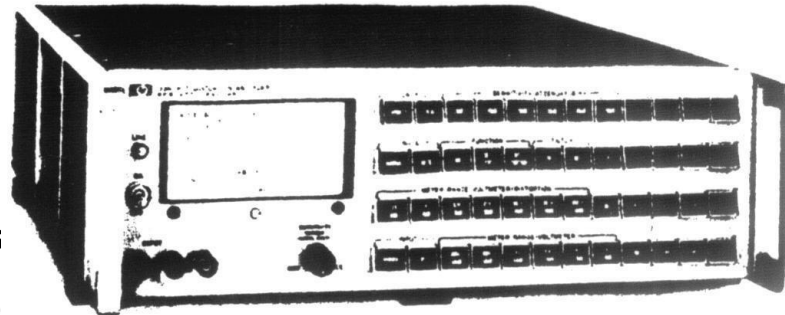

Fig. 15-2 L
(Court

WAVE ANALYZERS

- Harmonic distortion analyzers measure the total harmonic content in waveforms. It is frequently desirable to measure the amplitude of each harmonic individually. This is the simplest form of analysis in the frequency domain and can be performed with a set of tuned filters and a voltmeter.

WAVE ANALYZERS

- Such analyzes have various names, including frequency-selective voltmeters, carrier frequency voltmeters selective level meters and wave analyzers. Any of these names is quite descriptive of the instrument's primary function and mode of operation.

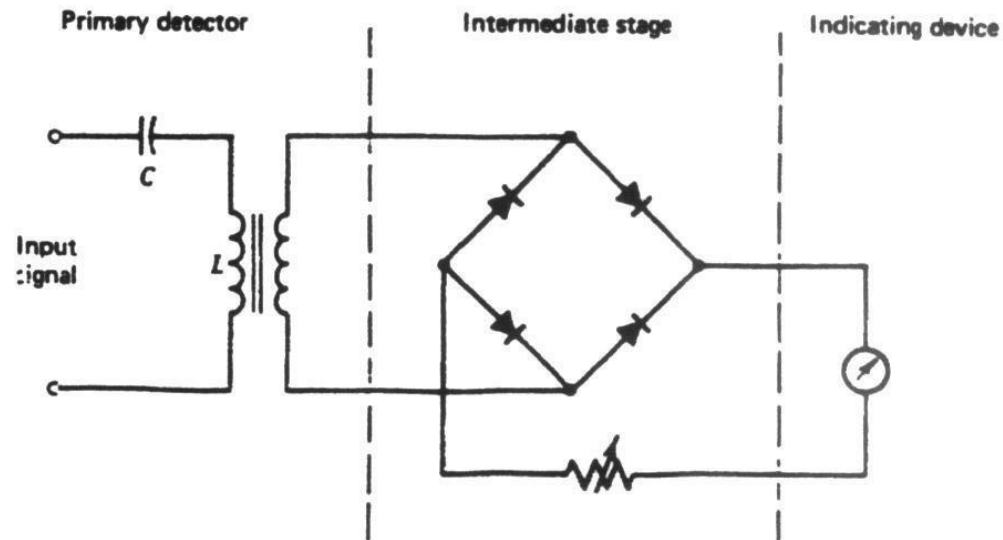

Fig. 3 Basic wave analyzer circuit

WAVE ANALYZERS

- A very basic wave analyzer is shown in Fig. 3. The primary detector is a simple LC circuit which is adjusted for resonance at the frequency of the particular harmonic component to be measured. The intermediate stage is a full-wave rectifier, and the indicating device may be a simple dc voltmeter that has been calibrated to read the peak value of a sinusoidal input voltage.

WAVE ANALYZERS

- Since the LC filter in Fig. 3 passes only the frequency to which it is tuned and provides a high attenuation to all other frequencies. many tuned filters connected to the indicating device through a selector switch would be required for a useful wave analyzer.

- Since wave analyzers sample successive portions of the frequency spectrum through a movable "window." as shown in Fig. 4, they are called non-real-time analyzers. However, if the signal being sampled is a periodic waveform, its energy distribution as a function of frequency does not change with time. Therefore, this sampling technique is completely satisfactory.
- Rather than using a set of tuned filters, the heterodyne wave analyzer shown in Fig. 5 uses a single, tunable, narrow-bandwidth filter, which may be regarded as the window through which a small portion of the frequency spectrum is examined at any one time.

WAVE ANALYZERS

- In this system, the signal from the internal, variable-frequency oscillator will heterodyne with the input signal to produce output signals having frequencies equal to the sum and difference of the oscillator frequency f_o and the input frequency f_i .

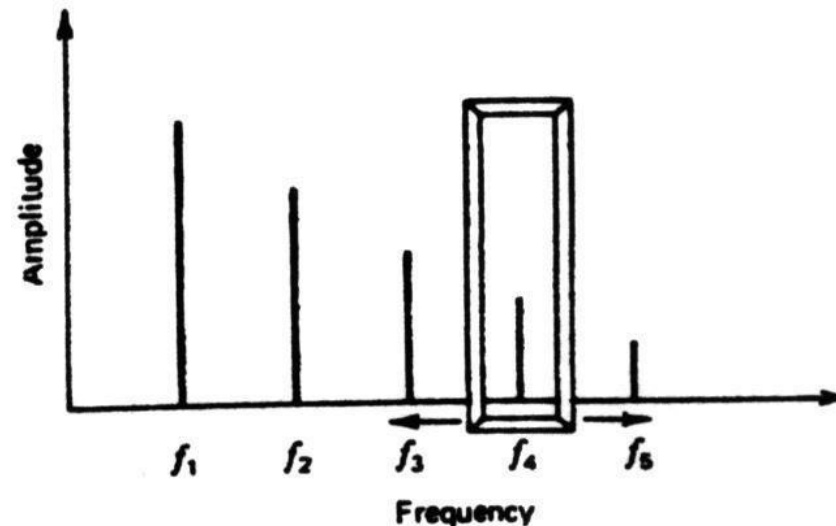
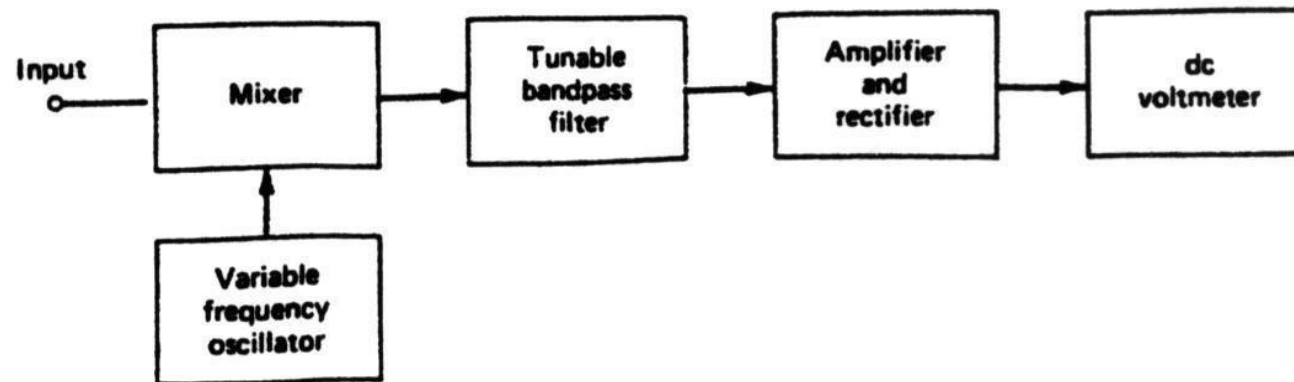

Fig. 15-4 Wave analyzer tunable filter or "window."

Heterodyne-type wave analyzer

- In a typical heterodyne wave analyzer, the band pass filter is tuned to a frequency higher than the maximum oscillator frequency. Therefore, the "sum frequency" signal expressed as is passed by the filter to the amplifier.

$$F_s = f_o + f_i$$



Heterodyne-type wave analyzer

- As the frequency of the oscillator is decreased from its maximum frequency, a point will be reached where $f_o + f_i$ is within the band of frequencies that the band pass filter will pass. The signal out of the filter is amplified and rectified.

Heterodyne-type wave analyzer

- The indicated quantity is amplified and rectified. The indicated quantity is then proportional to the peak amplitude of the fundamental component of the input signal. As the frequency of the oscillator is further decreased, the second harmonic and higher harmonics will be indicated.
- The bandwidth of the filter is very narrow, typically about 1 % of the frequency of interest. The attenuation characteristics of a typical commercial audio-frequency analyzer is shown in Fig. As can be seen, at $0.5f$ and at $2f$, attenuation is approximately 75 dB. The bandwidth of a heterodyne wave analyzer is usually constant.

An introduction to RF Spectrum Analysers

What is a RF Spectrum Analyser?

The name says it all – it is an instrument that enables the analysis of a spectrum.

In our case this is the Radio Frequency (RF) spectrum.

In its simplest form, a Spectrum Analyser is simply a radio receiver with a calibrated 'S meter'.

- Spectrum analysers are widely used to measure the frequency response, noise and distortion characteristics of all kinds of RF circuits by comparing the input and output spectra.
- In telecommunications applications, spectrum analysers can be used to determine the occupied bandwidth and track interference sources. In EMC testing applications, a spectrum analyser can be used for basic pre-compliance testing (detecting radiated and conducted emissions) .
- With suitable additions, such as a Tracking Generator and a VSWR Bridge, RF filters and band limited functions can be easily checked and transmission line losses/impedance mismatches plus antenna matching measurements at multiple frequencies is simply achieved.

A spectrum analyser may be used to determine if a wireless transmitter is working according to licence defined standards for purity of emissions.

Output signals at frequencies other than the intended communications frequency (harmonics) will be apparent on the display.

The analyser may also be used to determine, by direct observation, the bandwidth of a digital or analogue signal.

A spectrum analyser interface is a device that connects to a wireless receiver or a personal computer to allow visual detection and analysis of electromagnetic signals over a defined band of frequencies.

This is called panoramic reception and it is used to determine the frequencies of sources of interference to wireless networking equipment, such as Wi-Fi and wireless routers.

Spectrum analysers can also be used to assess RF shielding. This is particularly important for high RF power devices such as transmitters, where poor shielding can lead to unwanted cross coupling between units, or even danger to nearby personnel.

Difference between a Spectrum Analyser and an Oscilloscope

Both items enable measurement of the level of a signal, but,

An RF Spectrum Analyser measures a signal with respect to frequency, i.e. in the FREQUENCY DOMAIN

An Oscilloscope measures a signal with respect to time, i.e. in the TIME DOMAIN

An RF Spectrum Analyser usually presents a terminated input to the signal to be measured at a defined impedance – usually 50Ω

An Oscilloscope usually presents a high impedance input to the signal being measured (usually $1M\Omega$) but can be set to 50Ω as well for some instruments.

Signal Analysis, frequency and time domains

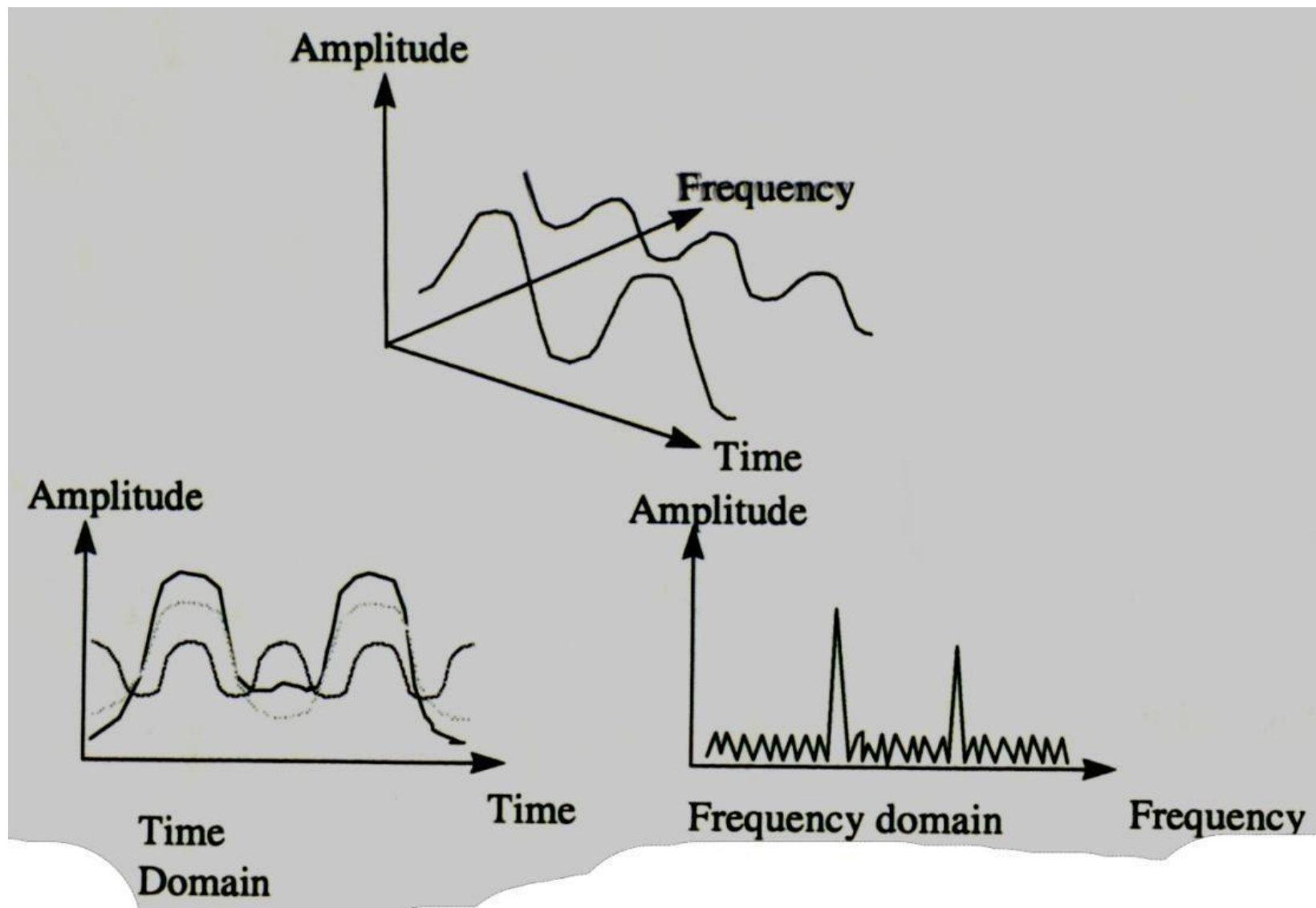

Oscilloscope Display, amplitude modulated signal

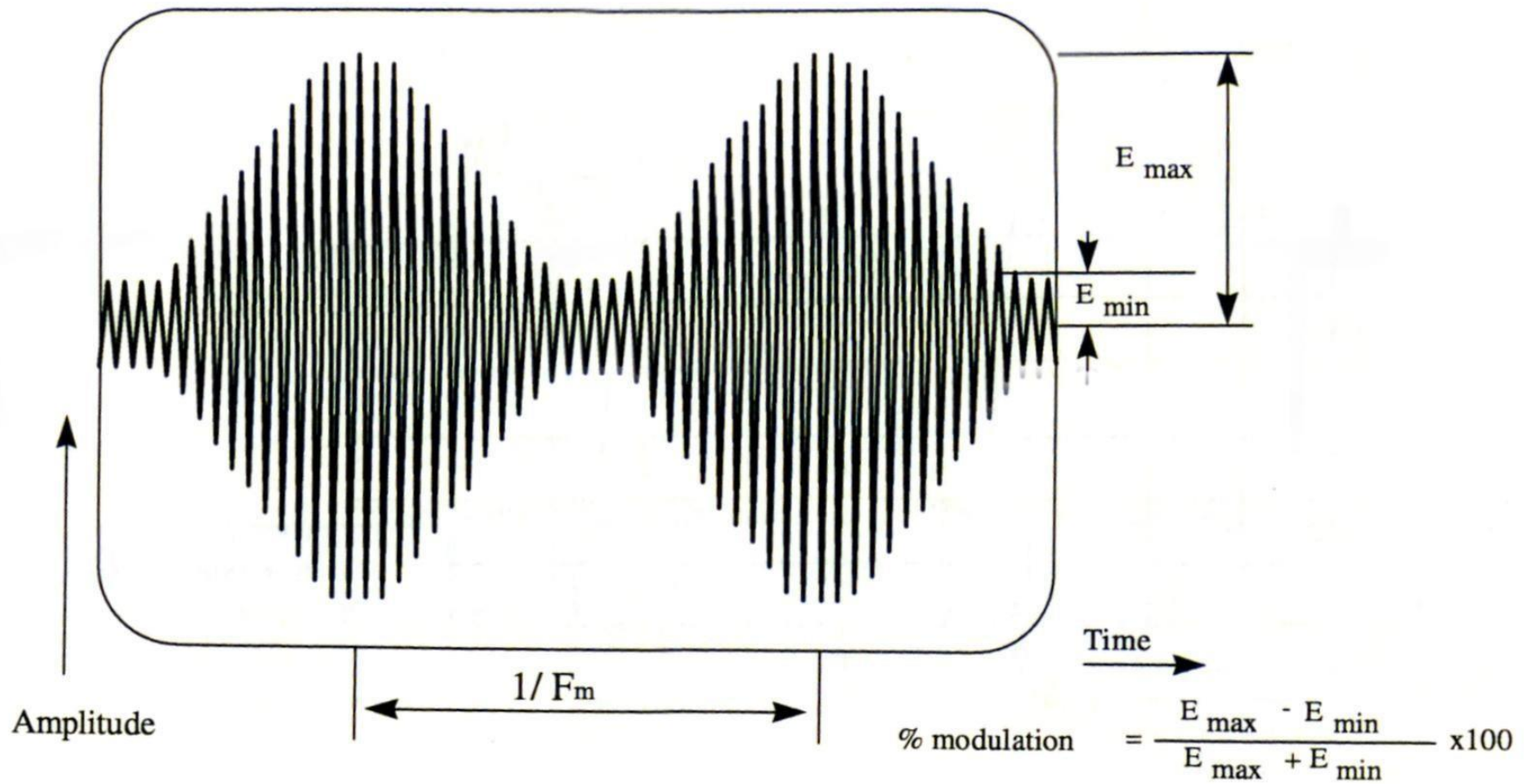

Spectrum Analyser Display, amplitude modulated signal

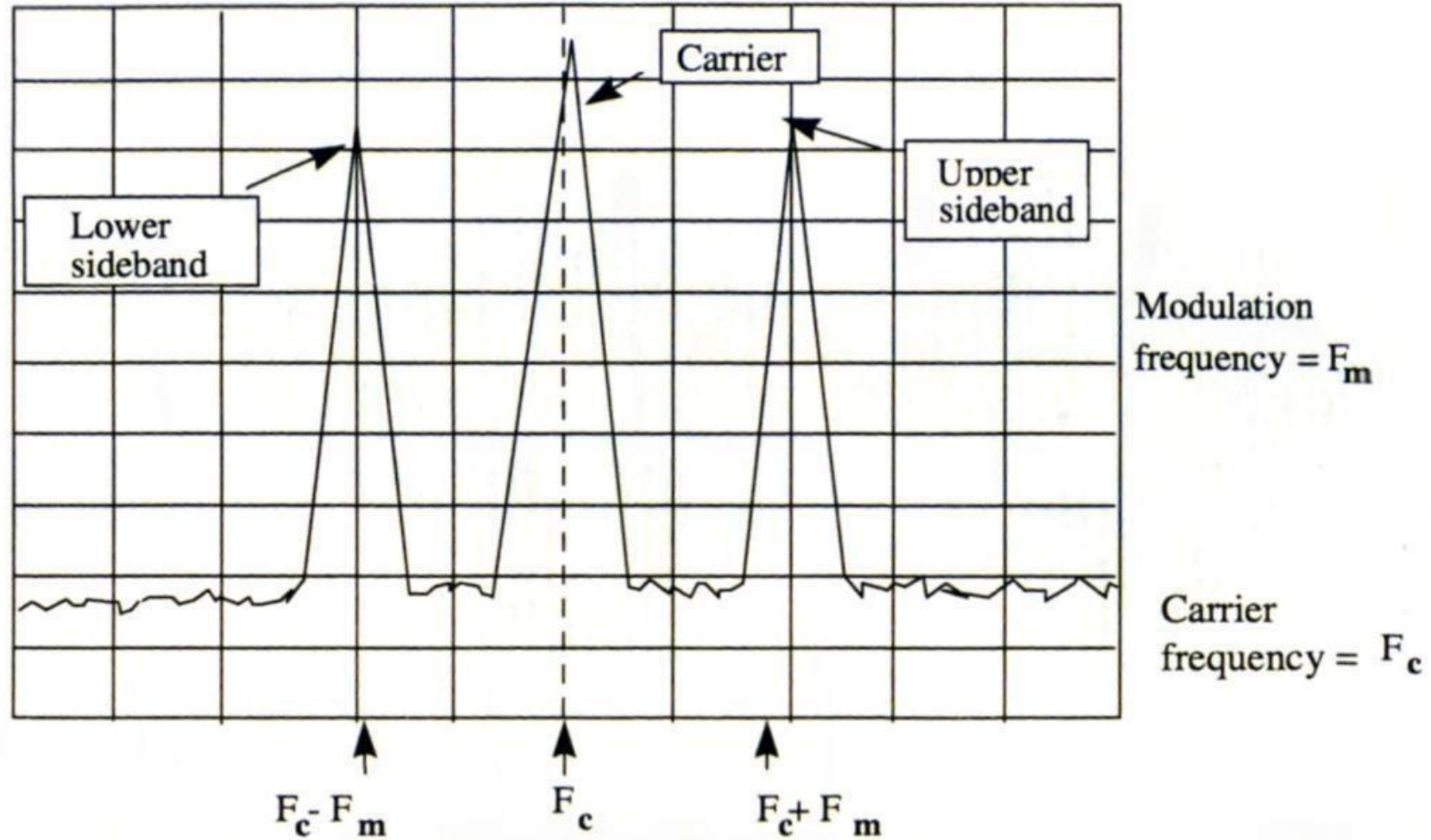

Spectrum Analyser Display, Harmonic Distortion

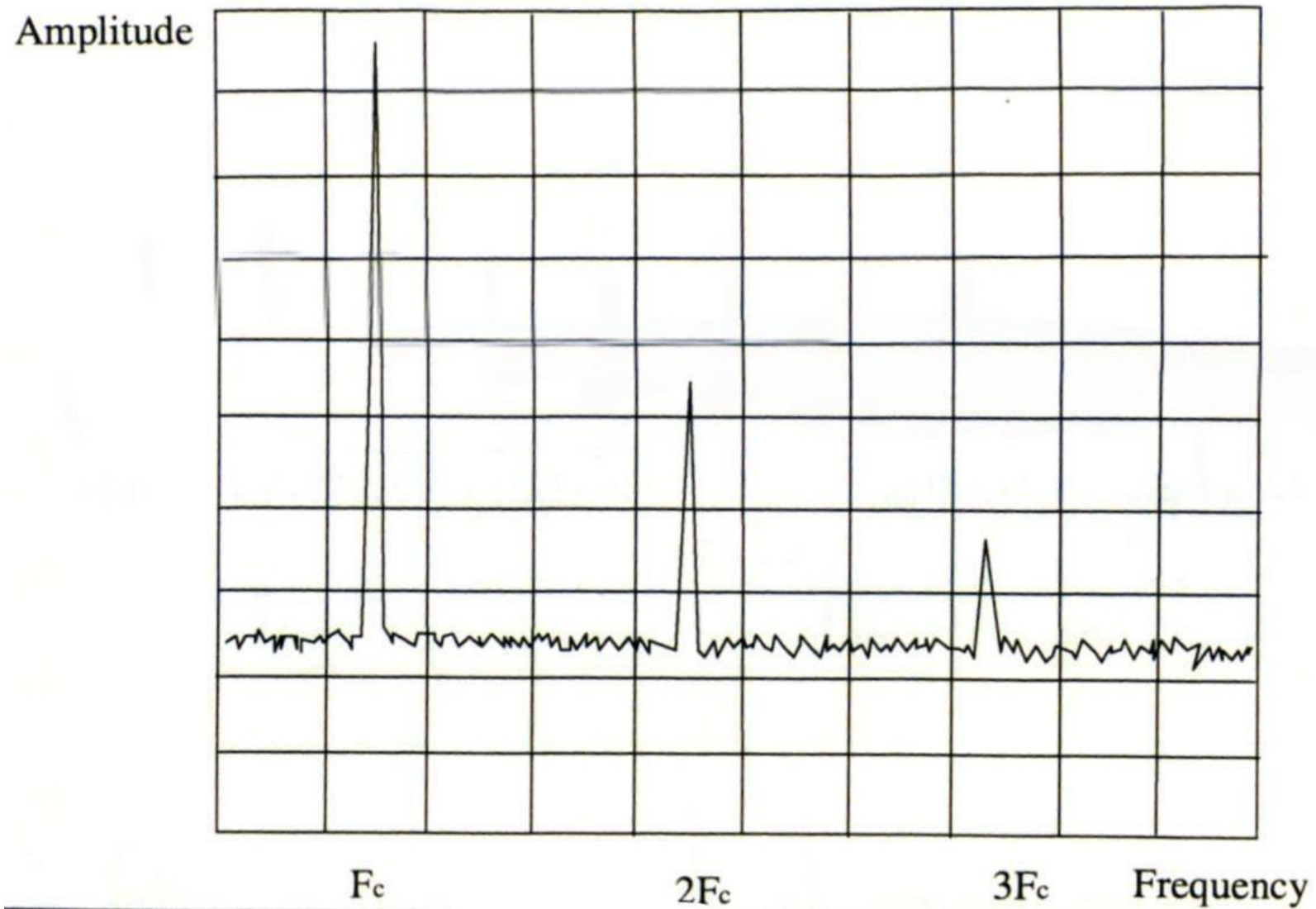

Spectrum Analyser Display, data signal



Spectrum Analyser types

Spectrum analyser types are defined by the methods used to obtain the spectrum of a signal.

Fundamentally, there are swept-tuned and FFT (Fast Fourier Transform) based spectrum analysers

Older instruments tend to be swept-tuned, whilst modern day instruments are usually FFT based, which take advantage of modern signal processing techniques.

Swept Tuned Spectrum Analyser

A swept-tuned spectrum analyser uses a super heterodyne receiver to down convert all, or a portion of the input signal spectrum, using a voltage controlled oscillator (VCO) and a mixer to the centre frequency of a band pass filter.

With this super heterodyne architecture, the VCO is swept through a range of frequencies, as selected by the instrument's SPAN control.

The bandwidth of the band pass filter dictates the resolution bandwidth, which is related to the minimum bandwidth detectable by the instrument.

FFT Spectrum Analyser

- A FFT spectrum analyser computes the Discrete Fourier Transform (DFT), a mathematical process that transforms the input signal waveform into the components of its frequency spectrum.
- Some spectrum analysers, such as real-time spectrum analysers, use a hybrid technique where the incoming signal is first down converted to a lower frequency using super heterodyne techniques and then analysed using Fast Fourier Transformation (FFT) techniques.

Spectrum Analyser, typical Block Diagram

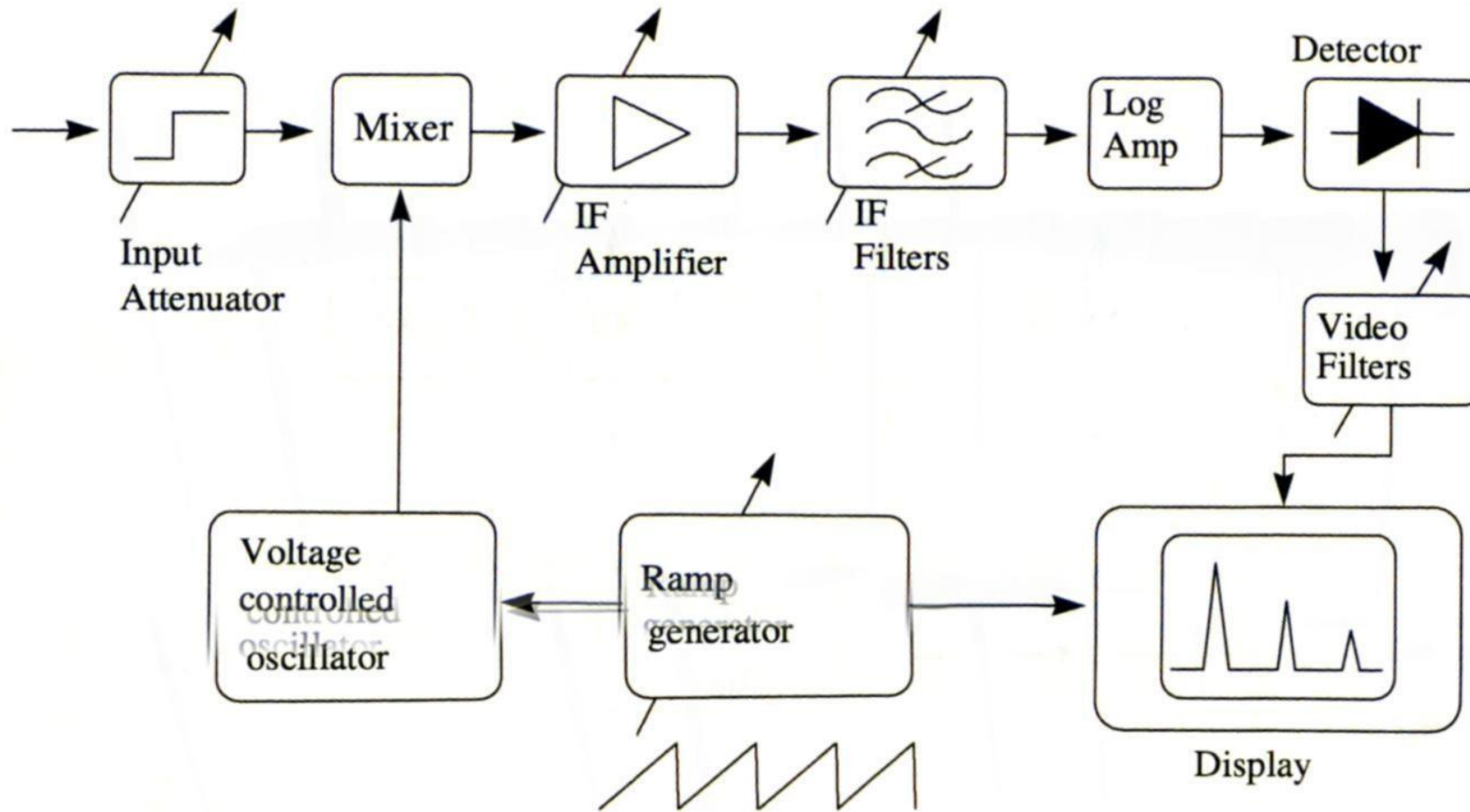

Terminology, Centre Frequency & Span

In a typical spectrum analyser there are options to set the start, stop, and centre frequency.

The frequency halfway between the stop and start frequencies on a spectrum analyser display is known as the centre frequency. This is the frequency that is in the middle of the display's frequency axis.

The Span specifies the range between the start and stop frequencies.

These two parameters allow for adjustment of the display within the frequency range of the instrument to enhance the visibility of the spectrum being measured.

Terminology, resolution bandwidth

- The bandwidth of the band pass filter dictates the resolution bandwidth, which is related to the minimum bandwidth detectable by the instrument.
- However, there is a trade-off between how quickly the display can update the full frequency span being examined and the frequency resolution presented, which is relevant for distinguishing frequency components that are close together.
- Here, selecting a slower rate (longer time) to traverse the selected frequency span enhances the achieved resolution.

Spectrum Analyzer

INTRODUCTION

- A spectrum in the practical sense is a collection of sine waves , when combined properly produces the required time domain signal.
- The frequency domain also has its measurement strengths.
- The frequency domain is better for determining the harmonic content of a signal.

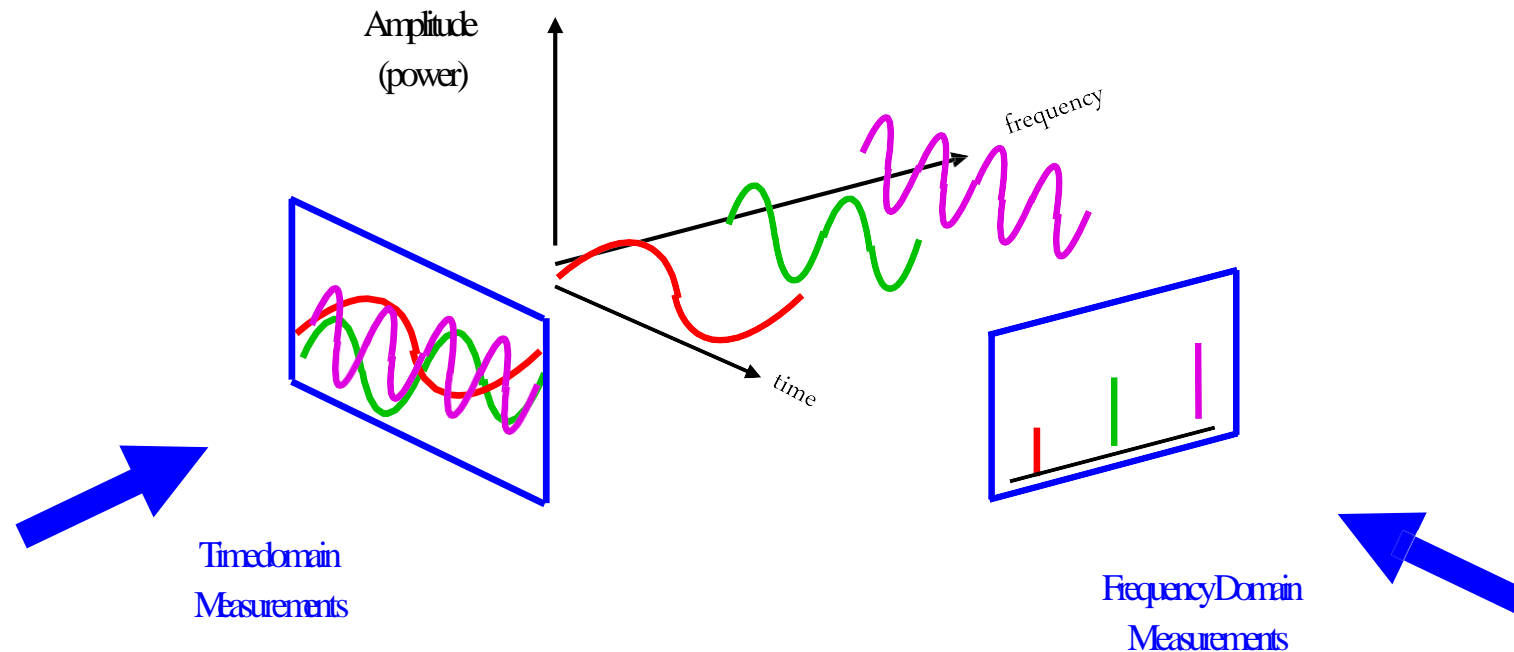



- A **spectrum analyzer** is a device used to examine the spectral composition of some electrical, acoustic, or optical waveform.
- Mostly it finds application in measurement of power spectrum .

Analog & Digital



- An *analog* spectrum analyzer uses either a variable band pass filter whose mid-frequency is automatically tuned (shifted, swept) through the range of frequencies of which the spectrum is to be measured or a super heterodyne receiver where the local oscillator is swept through a range of frequencies. A *digital* spectrum analyzer computes the Fast Fourier transform (FFT), a mathematical process that transforms a waveform into the components of its frequency spectrum

Spectrum Analysis

- In various field operations involving signals there is need to ascertain the nature of the signal at several points.
- Signal characteristics affect the parameters of operation of a system.
- Spectrum analysis mostly involves study of the signal entering a system or that produced by it .
- Spectrum analyzers usually display raw, unprocessed signal information such as voltage, power, period, wave shape, sidebands, and frequency. They can provide you with a clear and precise window into the frequency spectrum.

FFT Spectrum Analyzer

THE MEASUREMENT SYSTEM

- The analyzer is looking at the entire frequency range at the same time using parallel filters measuring simultaneously.
- It is actually capturing the time domain information which contains all the frequency information in it.
- With its real-time signal analysis capability, the Fourier analyzer is able to capture periodic as well as random and transient events.
- It also can provide significant speed improvement over the more traditional swept analyzer and can measure phase as well as magnitude.

Swept Spectrum Analyzer

- Very basically, these analyzers "sweep" across the frequency range of interest, displaying all the frequency components present.
- The swept-tuned analyzer works just like the AM radio in your home except that on your radio, the dial controls the tuning and instead of a display, your radio has a speaker.
- The swept receiver technique enables frequency domain measurements to be made over a large dynamic range and a wide frequency range.
- It has significant contributions to frequency-domain signal analysis for numerous **applications**, including the manufacture and maintenance of microwave communications links, radar, telecommunications equipment, cable TV systems, and broadcast equipment; mobile communication systems; EMI diagnostic testing; component testing; and signal surveillance.

Theory of Operation

Spectrum Analyzer Block Diagram

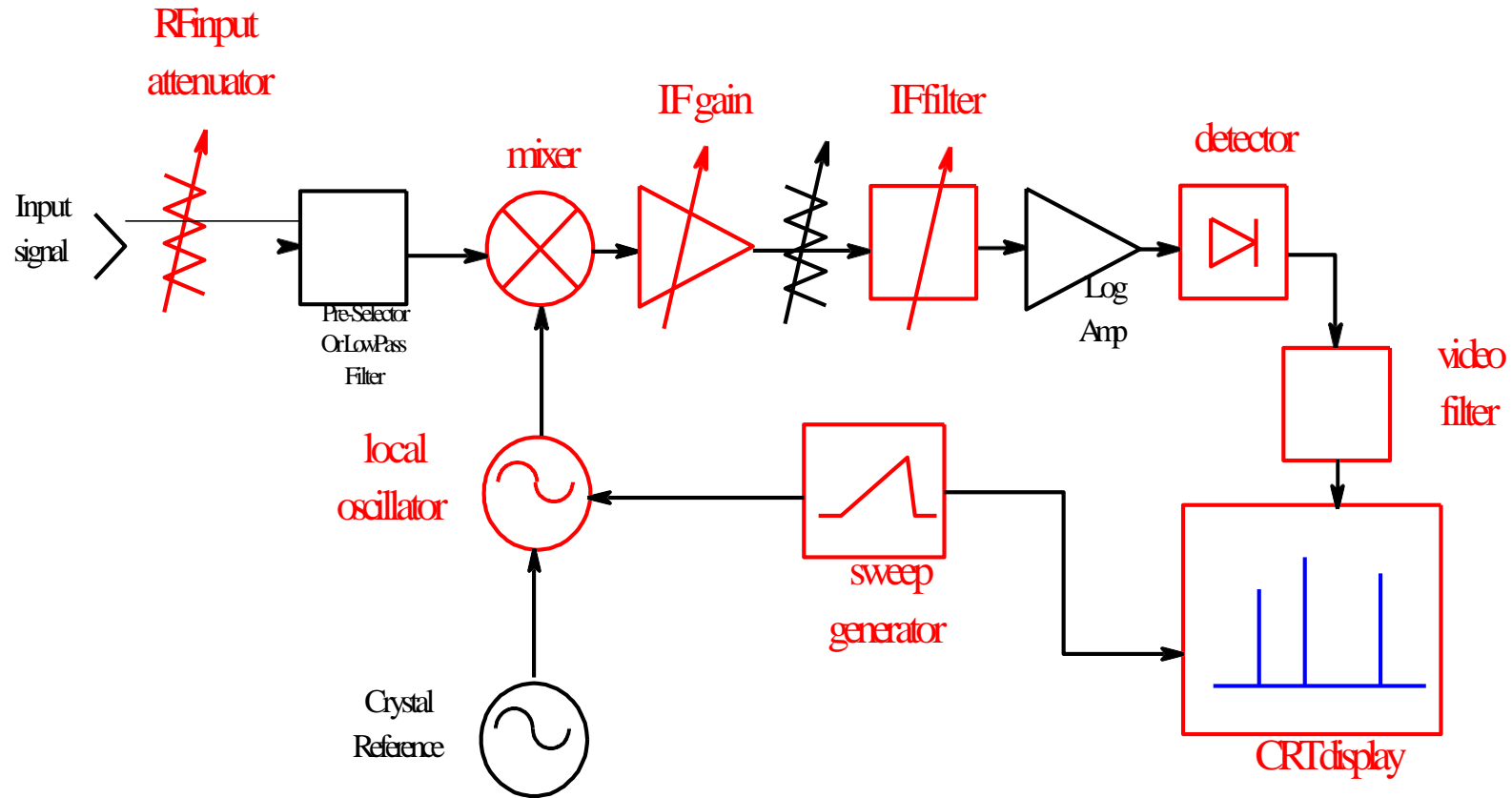

- The major components in a spectrum analyzer are the
 - RF input attenuator, mixer,
 - IF (Intermediate Frequency) gain,
 - IF filter, detector,
 - video filter
 - local oscillator,
 - sweep generator
 - CRT display.

MIXER

- A mixer is a device that converts a signal from one frequency to another.
- It is sometimes called a frequency-translation device.
- A mixer is a non-linear device (frequencies are present at the output that were not present at the input).
- The output of a mixer consists of the two original signals (f_{sig} and f_{LO}) as well as the sum ($f_{\text{LO}}+f_{\text{sig}}$) and difference ($f_{\text{LO}}-f_{\text{sig}}$) frequencies of these two signals.
- In a spectrum analyzer, the difference frequency is actually the frequency of interest. The mixer has converted our RF input signal to an IF (Intermediate Frequency) signal that the analyzer can now filter, amplify and detect for the purpose of displaying the signal on the screen.

IF FILTER

- The IF filter is a band pass filter which is used as the "window" for detecting signals.
- It's bandwidth is also called the resolution bandwidth (RBW) of the analyzer and can be changed via the front panel of the analyzer.
- By giving a broad range of variable resolution bandwidth settings, the instrument can be optimized for the sweep and signal conditions, letting trade-off frequency selectivity (the ability to resolve signals), signal-to-noise ratio (SNR), and measurement speed.
- As RBW is narrowed, selectivity is improved (we are able to resolve the two input signals). This will also often improve SNR.

Theory of Operation

Detector

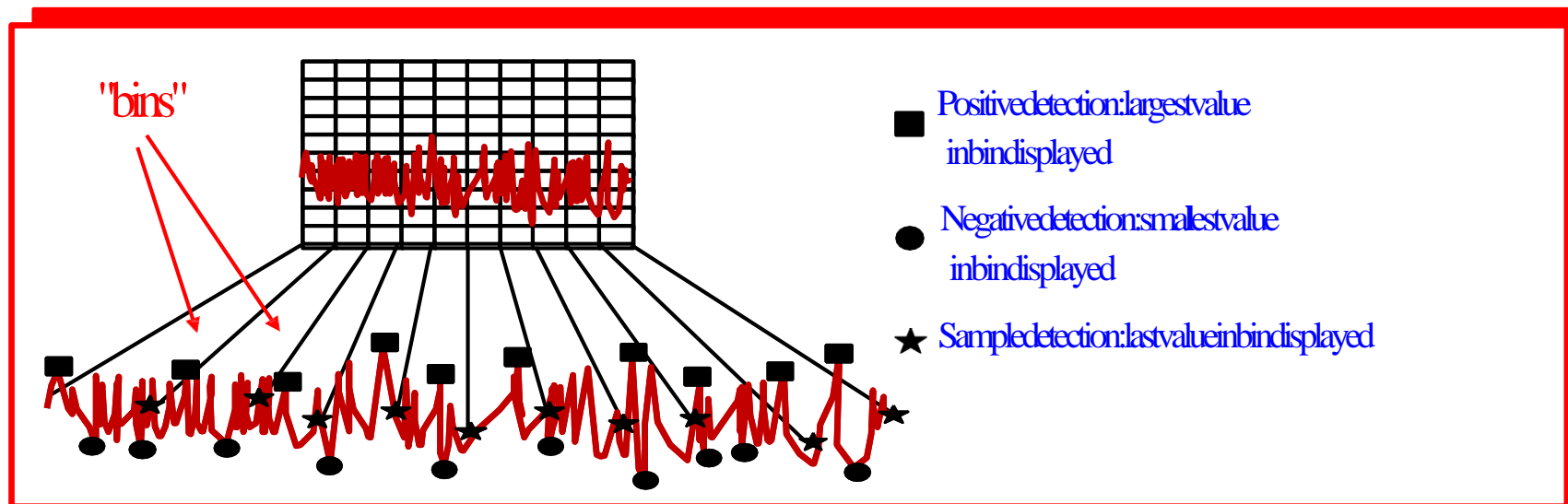
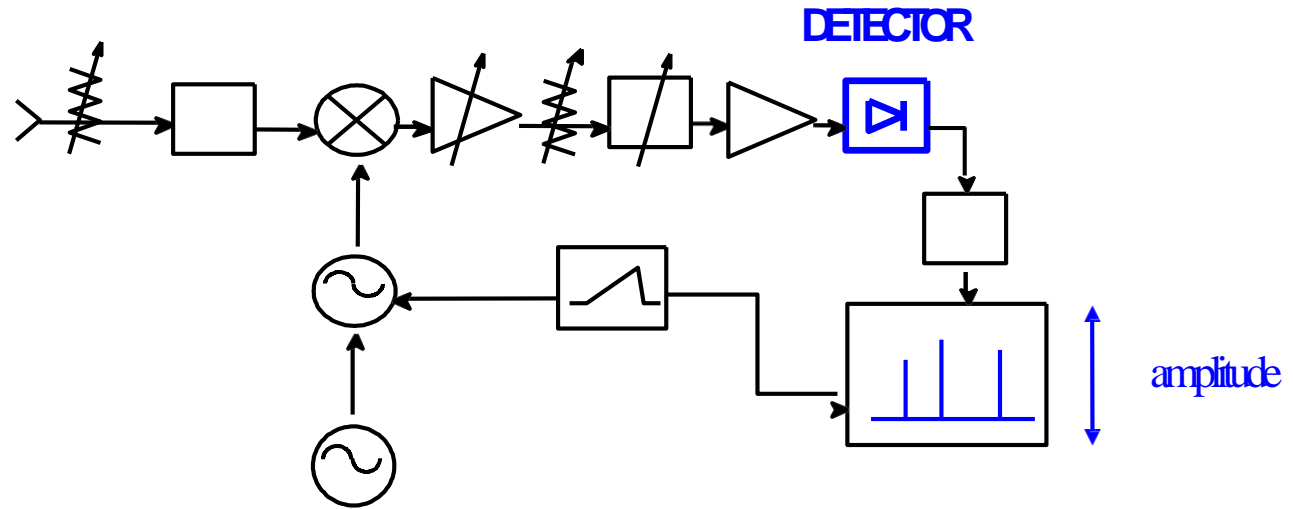

Continued...

- In *sample detection mode*, a random value for each "bin" of data (also called a trace element) is produced. This detector mode is best for computing the rms value of noise or noise-like signals, but it may miss the peaks of burst signals and narrowband signals when the RBW is narrower than the frequency spacing of the bins.
- For displaying both signals and noise, a detector mode called the *normal detector mode*

DETECTOR

- The analyzer must convert the IF signal to a baseband or video signal so it can be viewed on the instrument's display. This is accomplished with an envelope detector which then deflects the CRT beam on the y-axis, or amplitude axis. Many modern spectrum analyzers have digital displays which first digitize the video signal with an analog-to-digital converter (ADC). The *positive-peak detector mode* captures and displays the peak value of the signal over the duration of one trace element
- The *negative-peak detector mode* captures the minimum value of the signal for each bin.

Theory of Operation

Video Filter

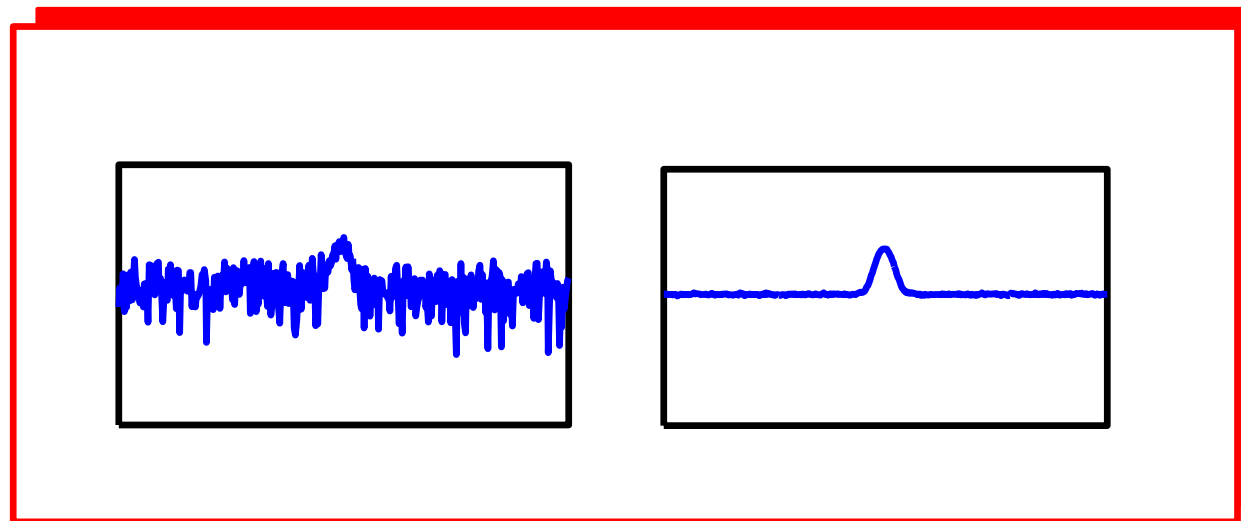
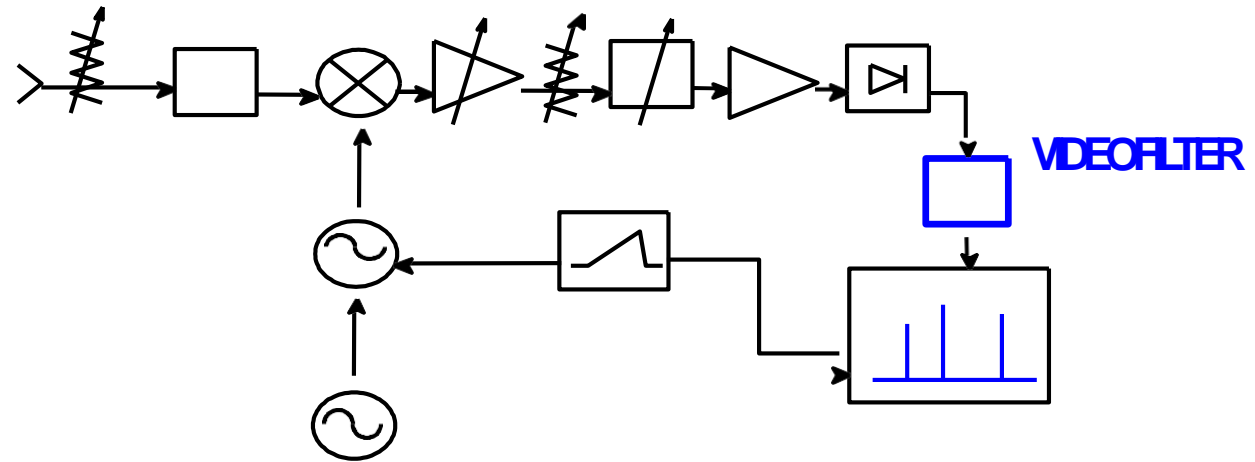

VIDEO FILTER

- The video filter is a low-pass filter that is located after the envelope detector and before the ADC.
- This filter determines the bandwidth of the video amplifier, and is used to average or smooth the trace seen on the screen.
- By changing the video bandwidth (VBW) setting, we can decrease the peak-to-peak variations of noise.

Theory of Operation

Other Components

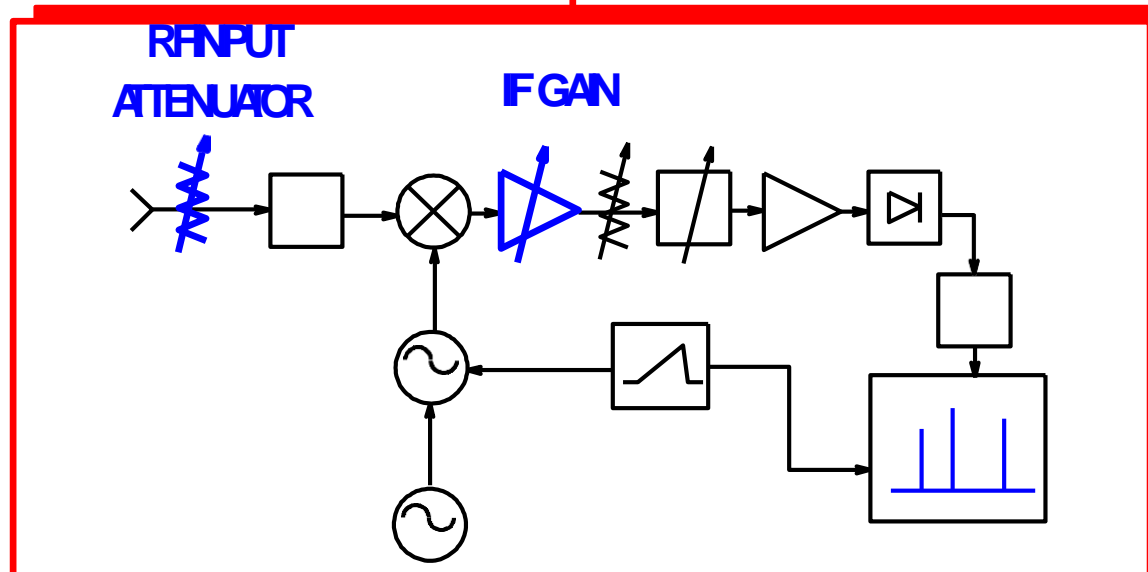
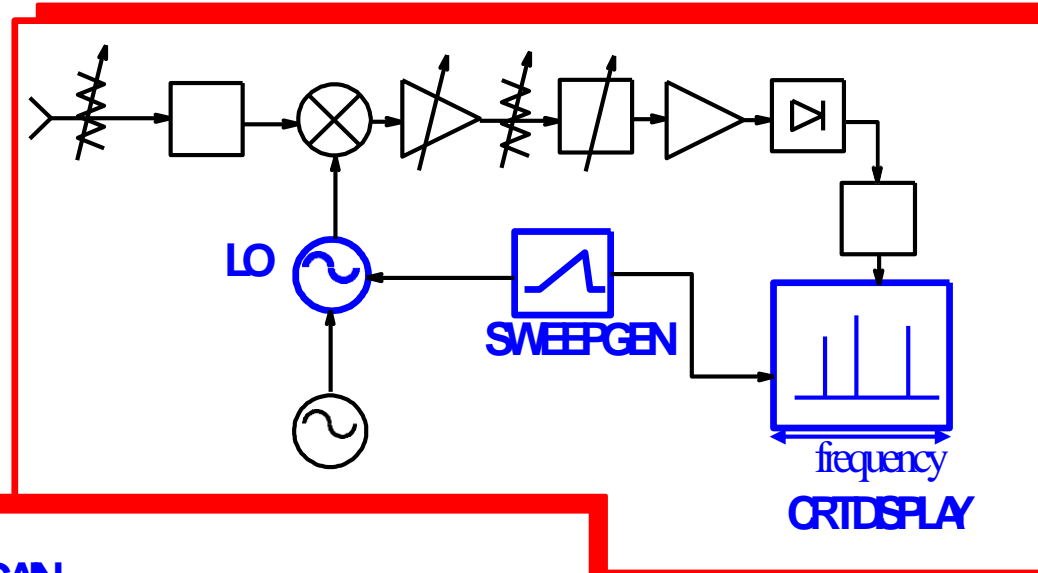

THE AUXILIARIES

- The *local oscillator* is a Voltage Controlled Oscillator (VCO) which in effect tunes the analyzer.
- The *sweep generator* actually tunes the LO so that its frequency changes in proportion to the ramp voltage.
- This also deflects the CRT beam horizontally across the screen from left to right, creating the frequency domain in the x-axis.
- The *RF input attenuator* is a step attenuator located between the input connector and the first mixer. It is also called the RF attenuator.
- This is used to adjust the level of the signal incident upon the first mixer.
- This is important in order to prevent mixer gain compression and distortion due to high-level and/or broadband signals.

Continued...

- The *IF gain* is located after the mixer but before the IF, or RBW, filter.
- This is used to adjust the vertical position of signals on the display without affecting the signal level at the input mixer.
- When it changed, the value of the reference level is changed accordingly.
- The IF gain will automatically be changed to compensate for input attenuator changes, so signals remain stationary on the CRT display, and the reference level is not changed.

Theory of Operation

How it all works together

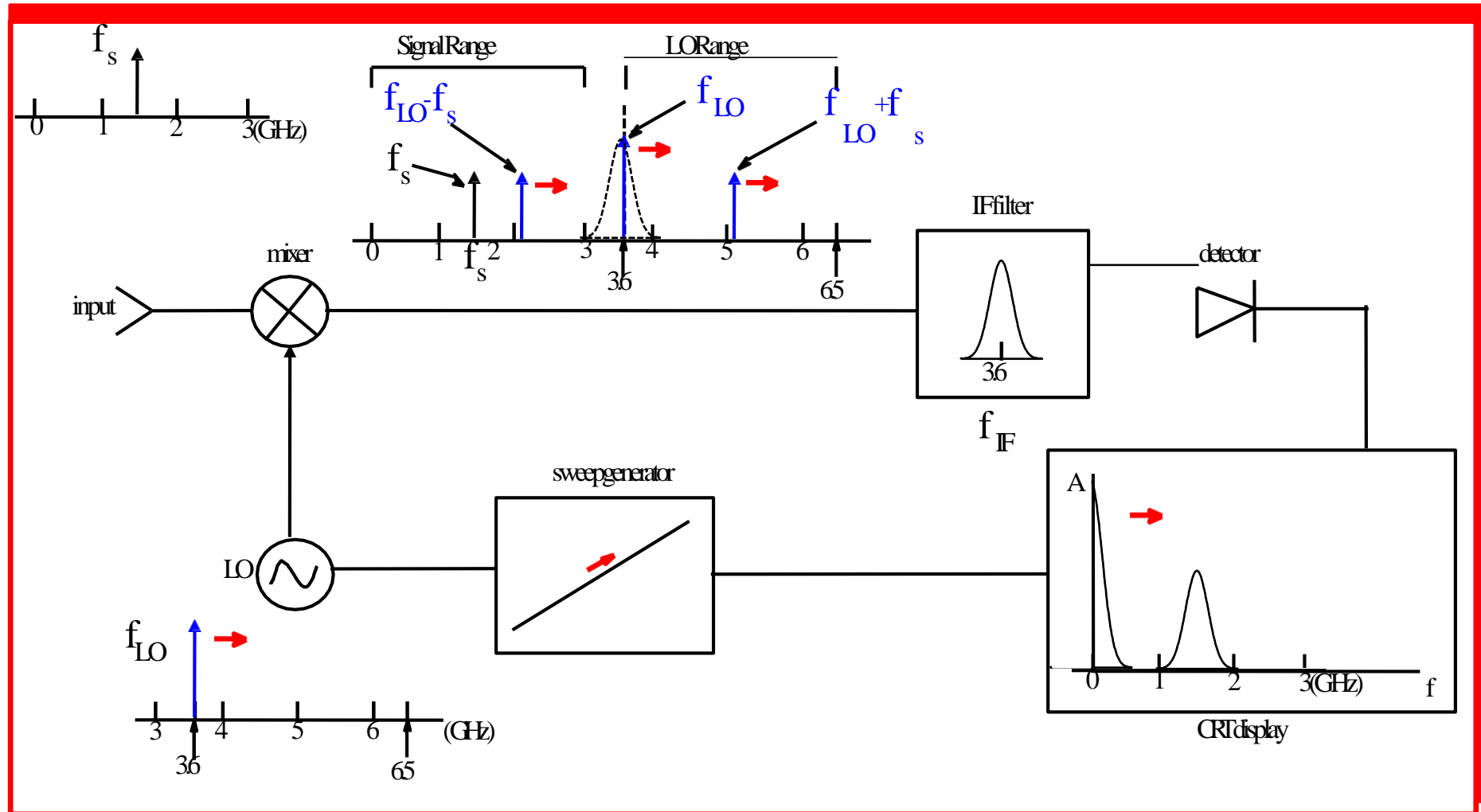

- First of all, the signal to be analyzed is connected to the input of the spectrum analyzer. This input signal is then combined with the LO through the mixer, to convert (or translate) it to an intermediate frequency (IF). These signals are then sent to the IF filter.
- The output of this filter is detected, indicating the presence of a signal component at the analyzer's tuned frequency. The output voltage of the detector is used to drive the vertical axis (amplitude) of the analyzer display.
- The sweep generator provides synchronization between the horizontal axis of the display (frequency) and tuning of the LO. The resulting display shows amplitude versus frequency of spectral components of each incoming signal.
- The horizontal arrows are intended to illustrate the "sweeping" of the analyzer. Starting with LO at 3.6 GHz, the output of the mixer has four signals, one of which is at 3.6 GHz (f_{LO}).

- IF filter is also at 3.6 GHz (it's shape has been imposed onto the frequency graph for clarity). Therefore, we expect to see this signal on the display. At 0 Hz on the CRT, we do indeed see a signal - this is called "LO Feedthrough".
- Sweep generator moving to the right, causes the LO to sweep upward in frequency. As the LO sweeps, so two will three of the mixer output signals (the input signal is stationary).
- As the LO Feedthrough moves out of the IF filter bandwidth, we see it taper off on the display. As soon as the difference frequency ($f_{LO}-f_s$) comes into the envelop of the IF filter, we start to see it.
- When it is at the center (e.g. 3.6 GHz) we see the full amplitude of this signal on the display.
- And, as it moves further to the right, it leaves the filter envelop, and no signal is seen on the display.
- The signal is being swept through the fixed IF filter, and properly displayed on the analyzer screen.

Theory of Operation

Front Panel Operation

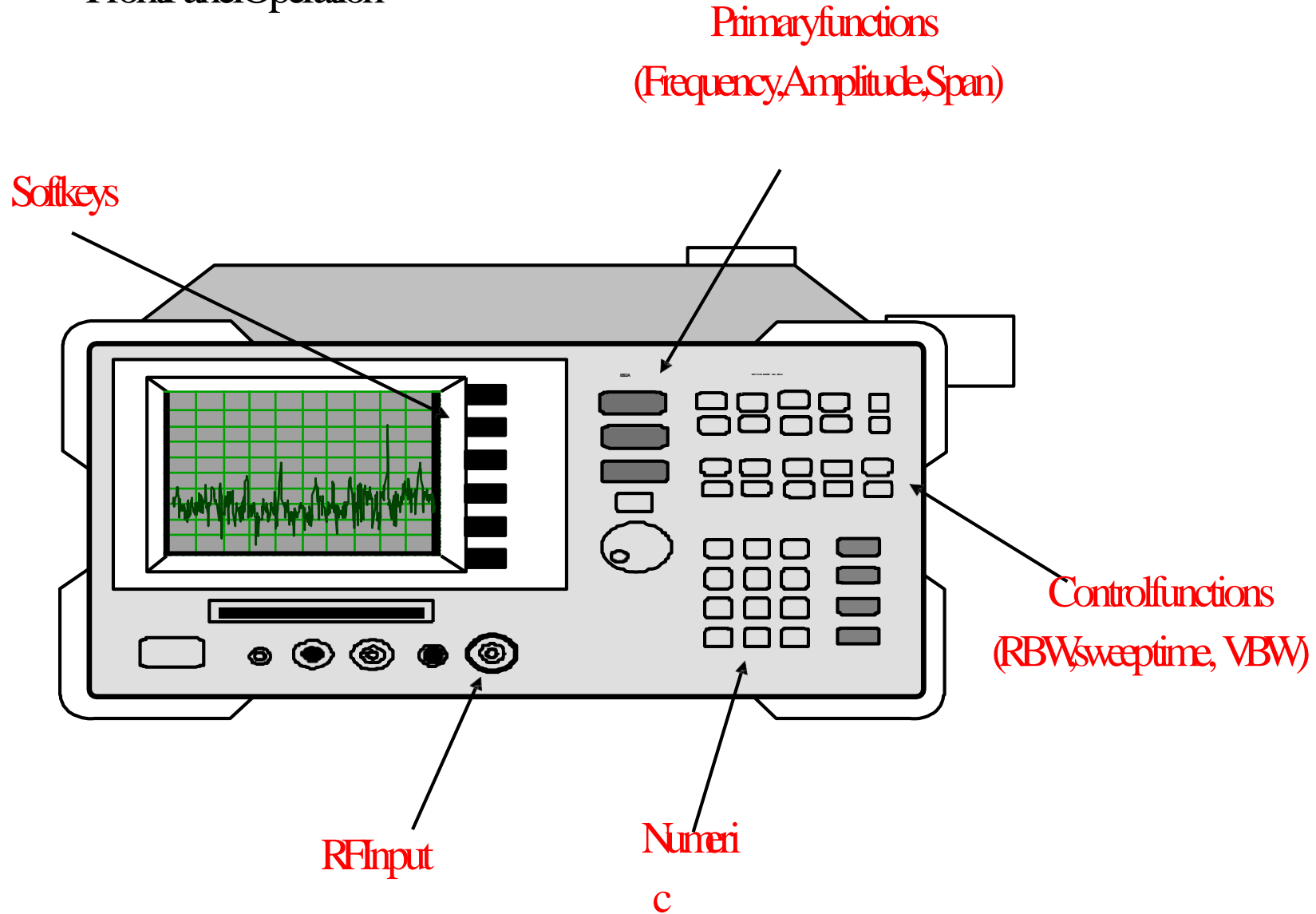

Signal Generator

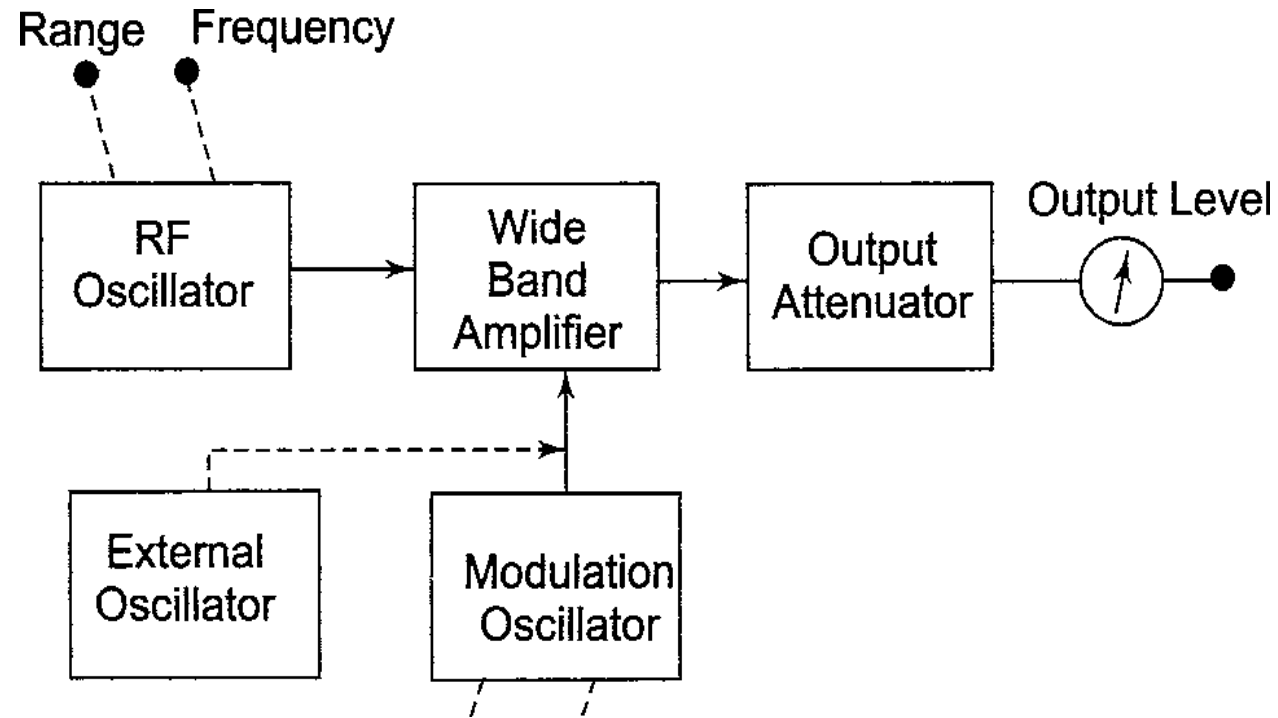

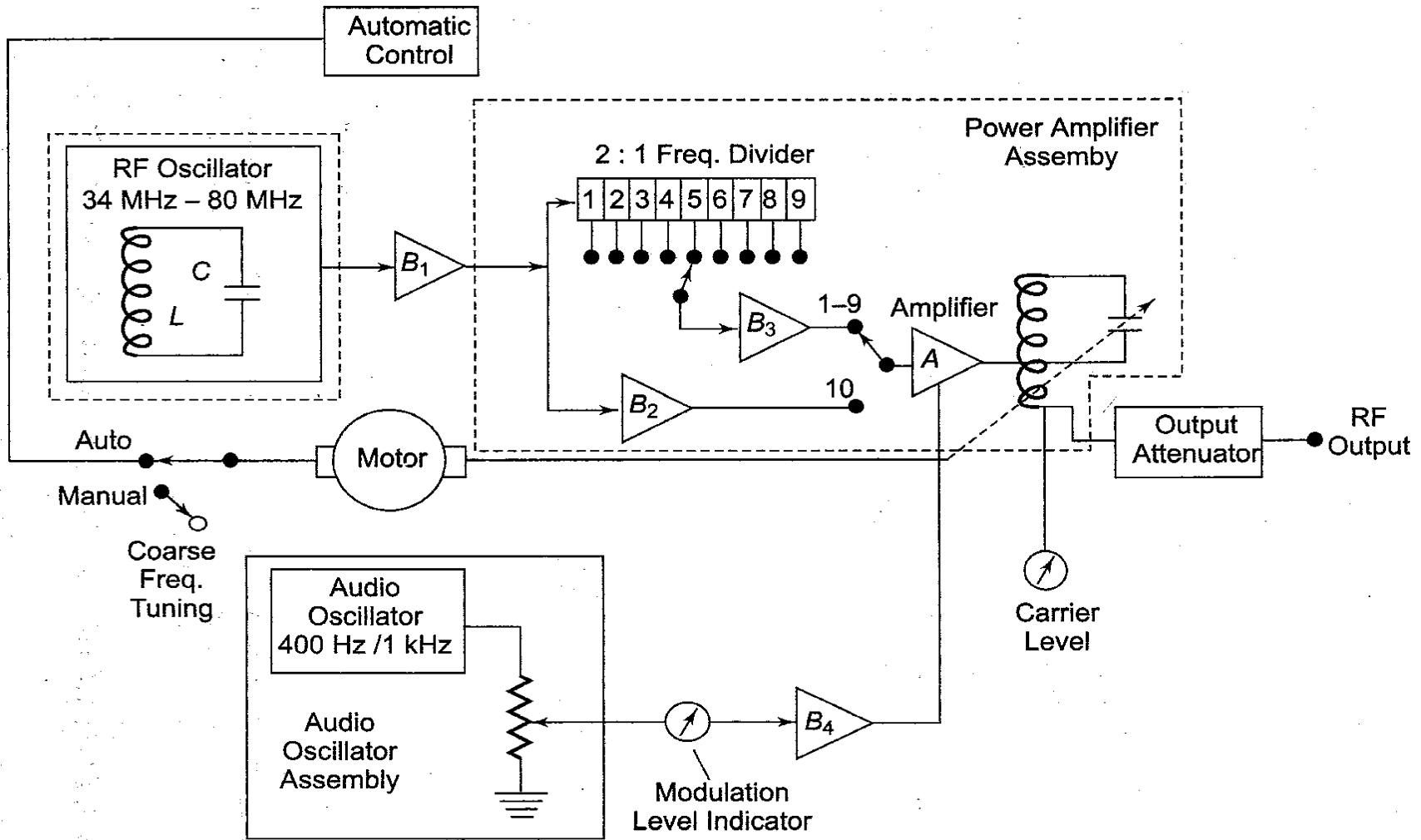

- Highest freq. ranges are provided by RF Oscillator (34MHz – 80MHz).
- „ Lowest freq. ranges are obtained by using **frequency divider**.
- ‰ 34MHz – 80MHz divided by 512 (2^9) \approx 67kHz – 156kHz.
- „ Buffer amplifiers (B_1 , B_2 , B_3) provide isolation between the master oscillator and power amplifier.
- ‰ Eliminates frequency effects (signal distortion) between input and output circuits.

❑ Compared to conventional std. signal gen, modern signal generator uses same oscillator on all bands.‰

❑ Eliminates range switching effects.

‰ Master oscillator is tuned by a motor driven variable capacitor.

„ Coarse freq. tuning – 7% frequency changes per second.

„ Fine tuning – at 0.01% of the main dial.

„ Modulation process is done at the power amplifier stage.

‰ Two internally generated signal are used (400Hz & 1kHz) for modulation.

FUNCTION GENERATOR

- „A **function generator** produces different waveforms of
- adjustable frequency.
- The common output waveforms are the sine, square, triangular.
- „The block diagram of a function generator is shown in Figure 3.
- Freq. Control – regulates two currents sources (control the freq).
- Upper current source – supplies constant current to the integrator, produces an output voltage .
- Lower current source – supplies a reverse current to the
- integrator so that its output decreases linearly with time.

FUNCTION GENERATOR

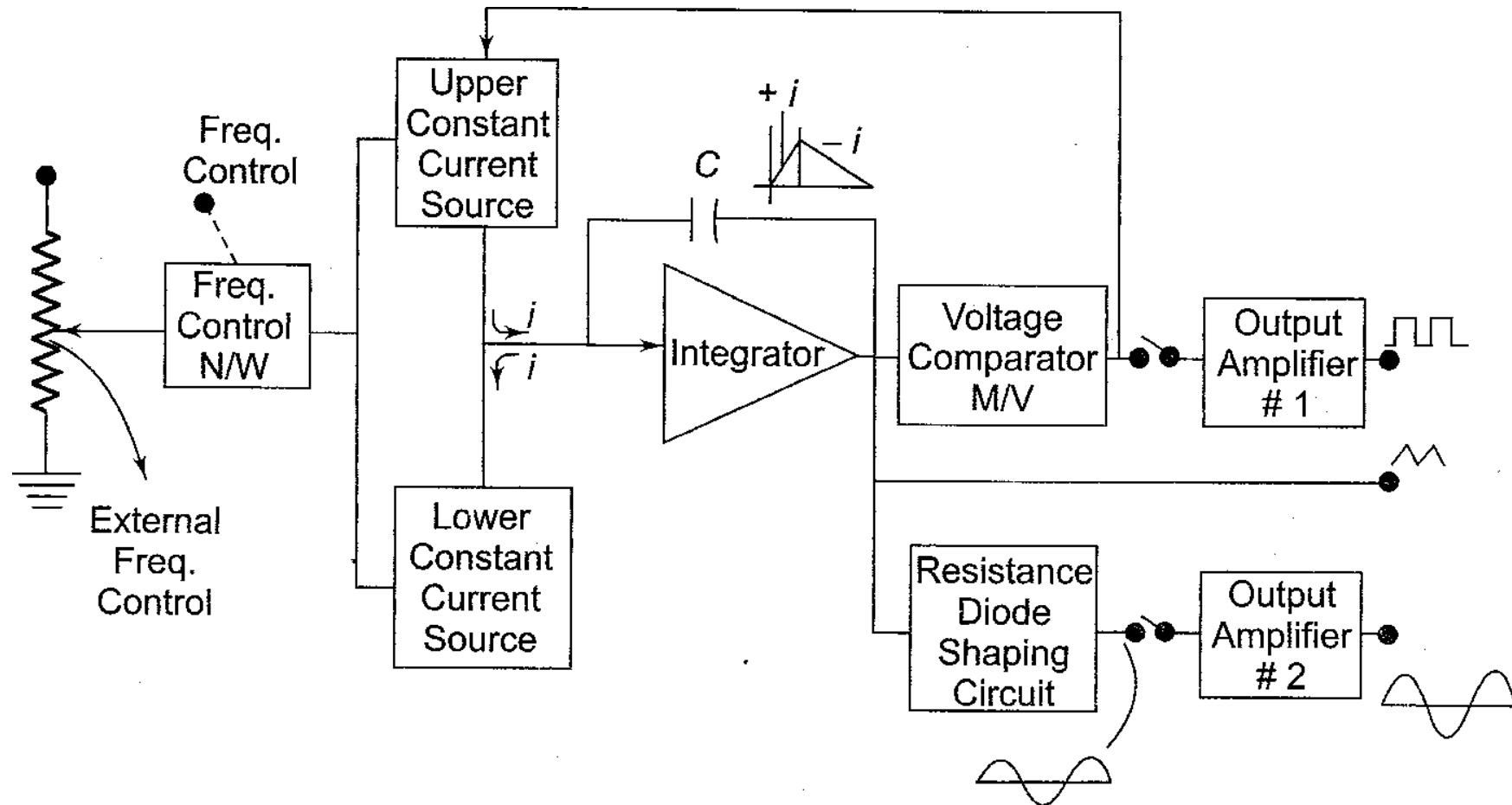

- Frequency is controlled by varying upper and lower currents.
- An increase or decrease in the current will increase or decrease the slope of the output voltage, hence controls the frequency.
- The **voltage comparator** – changes states at a pre-determined maximum and minimum level of the integrator output voltage.
- **When** the pre-determined level is reached, it changes the state and switches the current source.
- **Produces** a square wave.

- The **integrator** output is a triangular waveform whose frequency is determined by the magnitude of the constant current sources.
- The **comparator** output delivers a square wave of the same frequency.
- The **resistance diode network** produces a sine wave from the triangular wave with less than 1% distortion.

PULSE GENERATOR

- **Pulse generators** are instruments that produce a rectangular waveform similar to a square wave but with a different duty cycle.
- Duty cycle = pulse width/pulse period,,
- A square wave generator has a 50% duty cycle.
- The basic circuit for pulse generation is the **asymmetrical multi-vibrator**.
- Figure . shows block diagram of a pulse generator.

PULSE GENERATOR

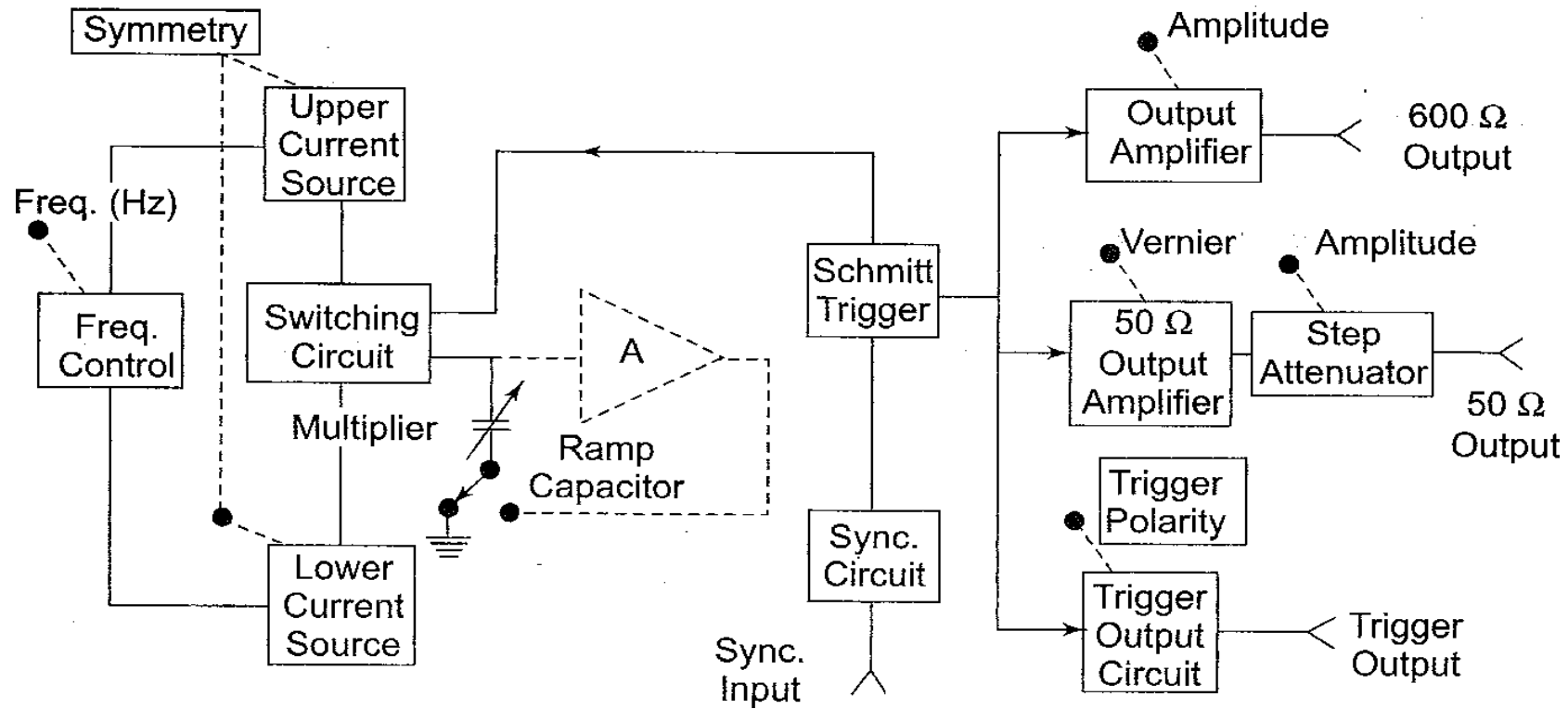

- „The duty cycle can be varied from 25 to 75%
 - Two independent outputs:
 - 50Ω - supplies pulses with a rise and fall time of 5ns at 5Vp.
 - 600Ω -supplies pulses with a rise and fall time of 70ns at 30Vp.
 - The instrument can operate as a free-running or can be
- Basic generating loop** consists of the current sources, the ramp capacitor, the Schmitt trigger, and the current switching circuit

PULSE GENERATOR

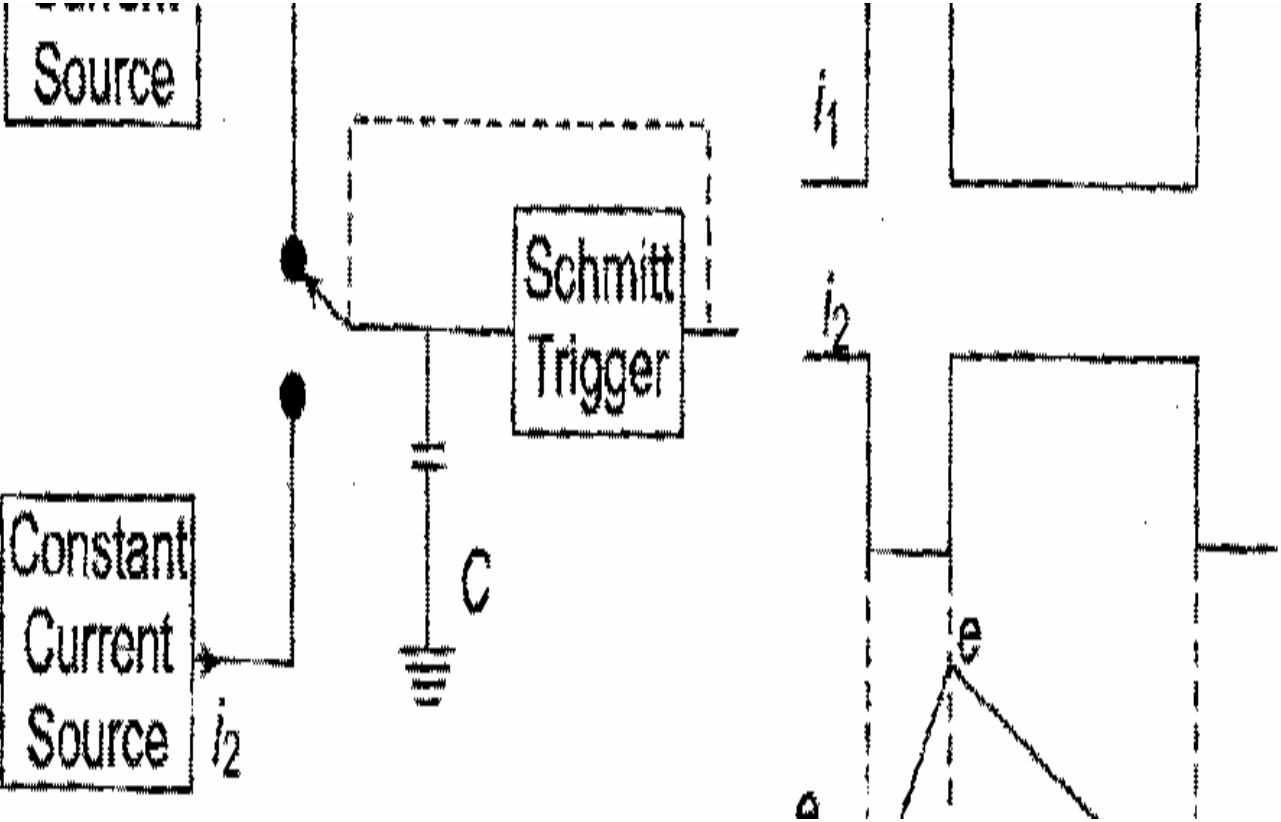

PULSE GENERATOR

- „Upper current source – supplies a constant current to the ramp capacitor and the capacitor voltage increases linearly.
- When the positive slope of the ramp reaches the upper limit
- Schmitt trigger will change a state
- Reverses the condition of the current switch.
- Capacitor discharges linearly. (lower current source takes part)
- When the negative slope of the ramp reaches the lower limit, upper current will control the circuit.
- The process is repeated.
- The ratio i_1/i_2 determines the duty cycle, and is controlled by **symmetry control**. The sum of i_1 and i_2 determines the frequency.
- The size of the capacitor is selected by the **multiplier switch**.

SWEEP GENERATOR

- **Sweep frequency generators** are instruments that provide a sine wave in the RF range.
- Its frequency can be varied smoothly and continuously over an entire frequency band.
- Figure 8 shows the block diagram of the sweep generator.
- The **frequency sweeper** provides a varying sweep voltage for synchronization to drive the horizontal deflection plates of the CRO.
- „ A sweep rate can be of the order of 20 sweeps/sec.
- „ Figure 9 shows the modulated sinewave by a **voltage-controlled oscillator** (VCO).

SWEEP GENERATOR

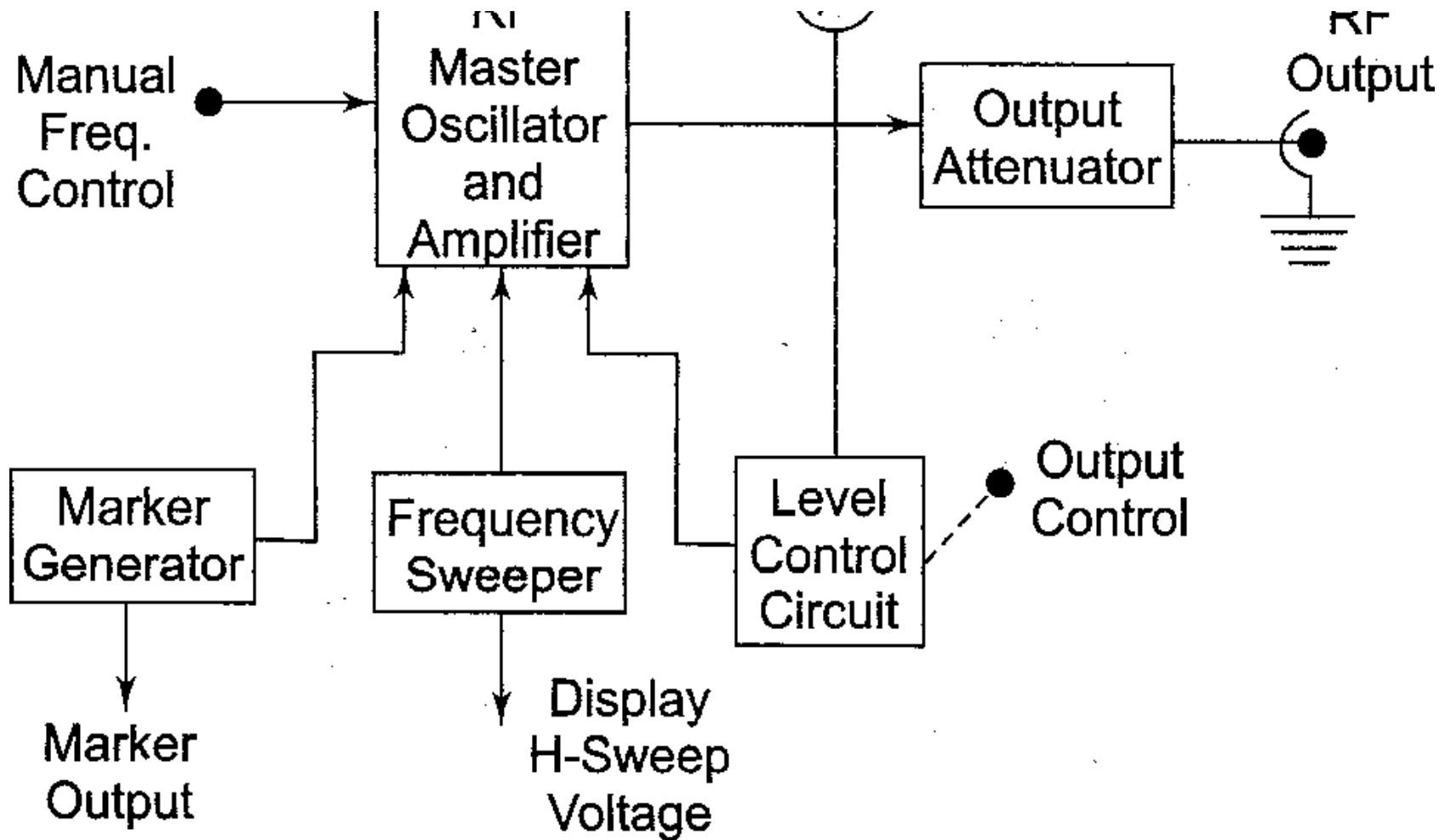

- Radio Frequency Generator
- **Radio frequency generators** are designed to provide an output signal over a wide range of frequencies from approximately 30 kHz to nearly 3000 MHz.
- Contain a precision output attenuator network that permits selection of output voltages from 1 uV to 3V in precise steps.

output impedance= 50Ω .

- „Figure. shows a block diagram for a basic RF signal generator.
- The frequency range is selected with the **band selector** and exact freq. is selected with the Vernier freq. selector.
- Broadband amplifier – provides buffering between the oscillator and the load connected to the output terminal.
- The output of the attenuator is monitored by the output meter.

UNIT-III

OSCILLOSCOPES

Objectives:

- This final chapter discusses the key instruments of electronic measurement with special emphasis on the most versatile instrument of electronic measurement—the cathode-ray oscilloscope (CRO).
- The objective of this book will remain unrealized without a discussion on the CRO.
- The chapter begins with the details of construction of the CRO, and proceeds to examine the active and passive mode input–output waveforms for filter circuits and lead-lag network delay.
- This will be followed by a detailed study of the dual beam CRO and its uses in op-amp circuit integrator, differentiator, inverting and non-inverting circuits, comparative waveform study, and accurate measurement with impeccable visual display.
- In addition to the CRO, the chapter also examines the sweep frequency generator, the function generator, the sine wave generator, the square wave generator and the AF signal generator.

INTRODUCTION:

- The cathode-ray oscilloscope (CRO) is a multipurpose display instrument used for the observation, measurement, and analysis of waveforms by plotting amplitude along *y-axis* and *time* along *x-axis*.
- *CRO is generally an x-y plotter; on a single screen it can display different signals applied to different channels. It can measure amplitude, frequencies and phase shift of various signals. Many physical quantities like temperature, pressure*
- and strain can be converted into electrical signals by the use of transducers, and the signals can be displayed on the CRO.
- A moving luminous spot over the screen displays the signal. CROs are used to study waveforms, and other time-varying phenomena from very low to very high frequencies.
- The central unit of the oscilloscope is the cathode-ray tube (CRT), and the remaining part of the CRO consists of the circuitry required to operate the cathode-ray tube.

Block diagram of a cathode-ray oscilloscope:

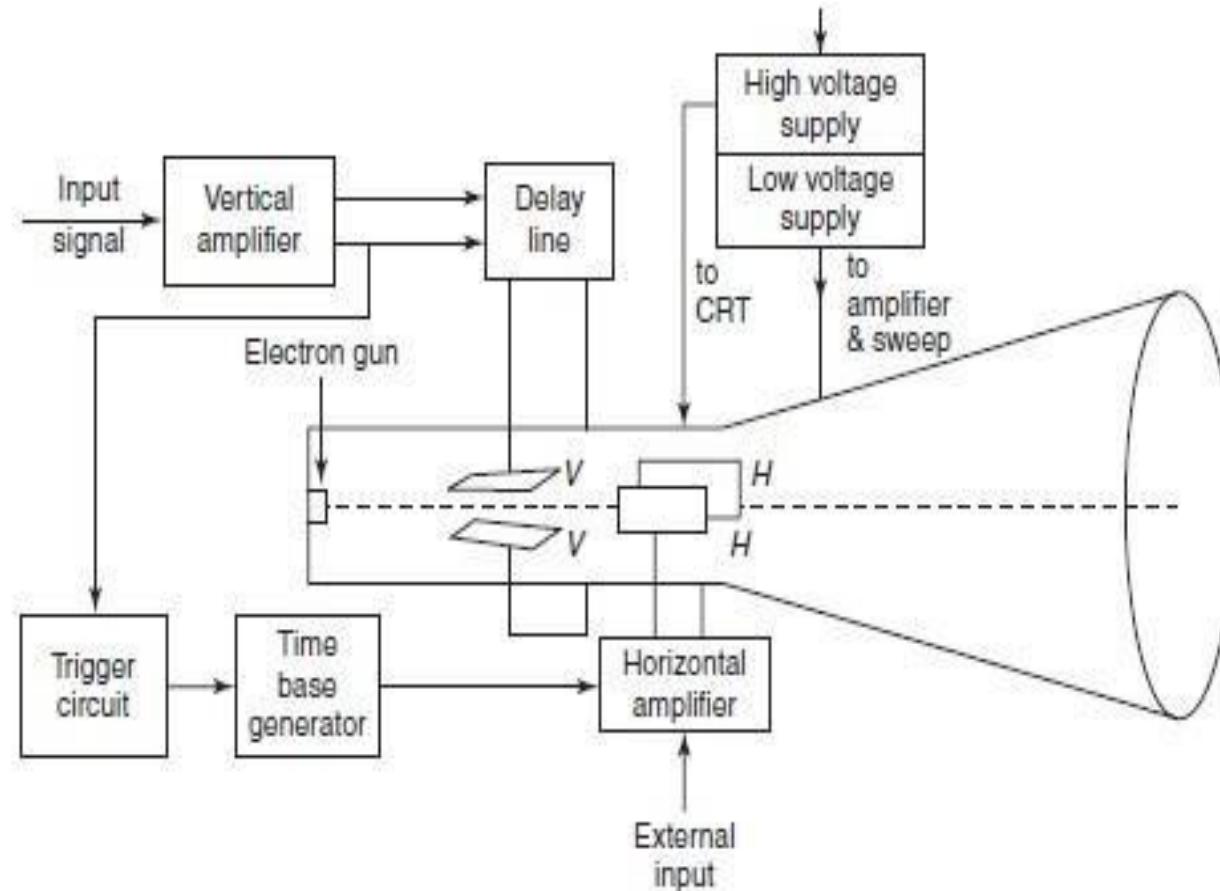

Figure 14-1 Block diagram of a cathode-ray oscilloscope

COMPONENTS OF THE CATHODE-RAY OSCILLOSCOPE:

The CRO consists of the following:

- (i) CRT
- (ii) Vertical amplifier
- (iii) Delay line
- (iv) Horizontal amplifier
- (v) Time-base generator
- (vi) Triggering circuit
- (vii) Power supply

CATHODE-RAY TUBE

- The **electron gun or electron emitter, the deflecting system** and **the fluorescent screen** are the three major components of a general purpose CRT. A detailed diagram of the cathode-ray oscilloscope is given in Fig. 14-2.

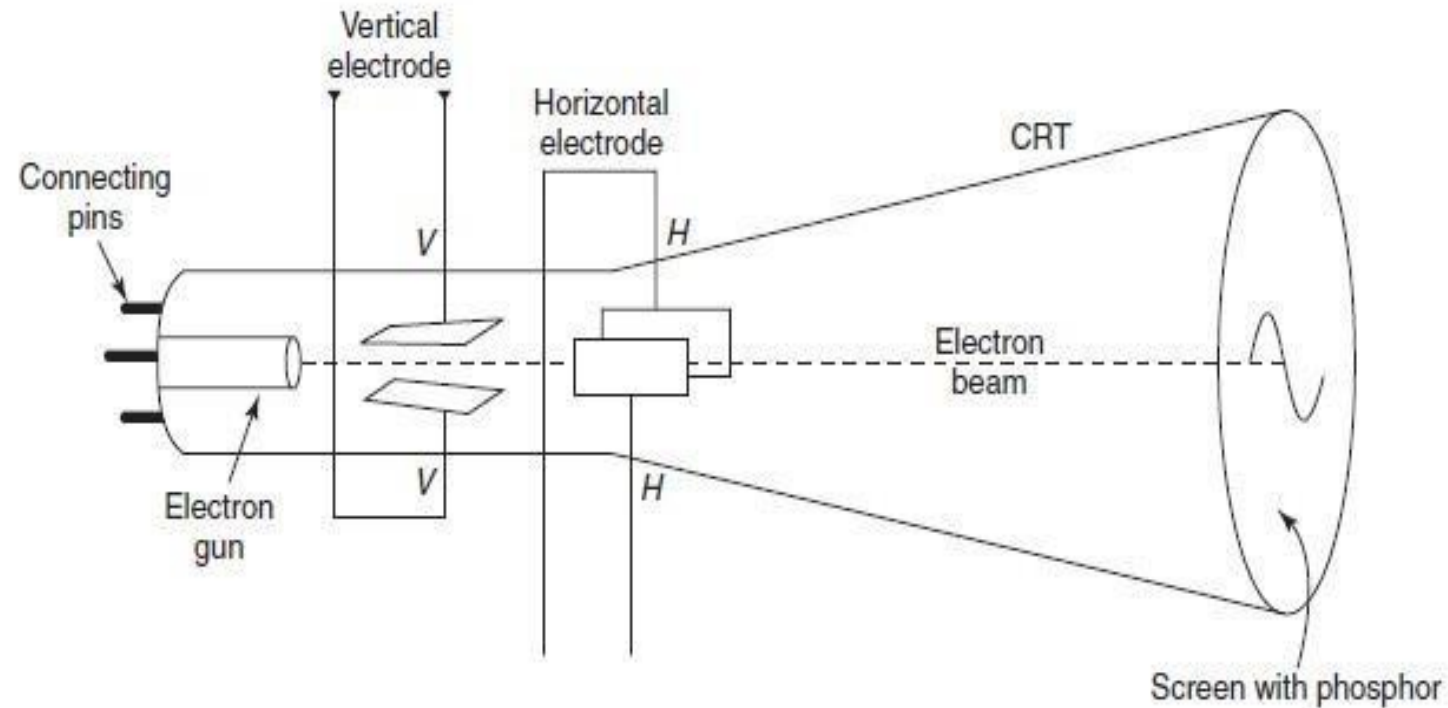

Figure 14-2 Components of a cathode-ray oscilloscope

Electron Gun:

- In the electron gun of the CRT, electrons are emitted, converted into a sharp beam and focused upon the fluorescent screen.
- The electron beam consists of an indirectly heated cathode, a control grid, an accelerating electrode and a focusing anode.
- The electrodes are connected to the base pins. The cathode emitting the electrons is surrounded by a control grid with a fine hole at its center.
- The accelerated electron beam passes through the fine hole.
- The negative voltage at the control grid controls the flow of electrons in the electron beam, and consequently, the brightness of the spot on the CRO screen is controlled.

Deflection Systems:

- Electrostatic deflection of an electron beam is used in a general purpose oscilloscope. The deflecting system consists of a pair of horizontal and vertical deflecting plates.
- Let us consider two parallel vertical deflecting plates $P1$ and $P2$. The beam is focused at point O on the screen in the absence of a deflecting plate voltage.
- If a positive voltage is applied to plate $P1$ with respect to plate $P2$, the negatively charged electrons are attracted towards the positive plate $P1$, and these electrons will come to focus at point $Y1$ on the fluorescent screen.

Deflection Systems:

- *The deflection is proportional to the deflecting voltage between the plates. If the polarity of the deflecting voltage is reversed, the spot appears at the point Y_2 , as shown in Fig.*

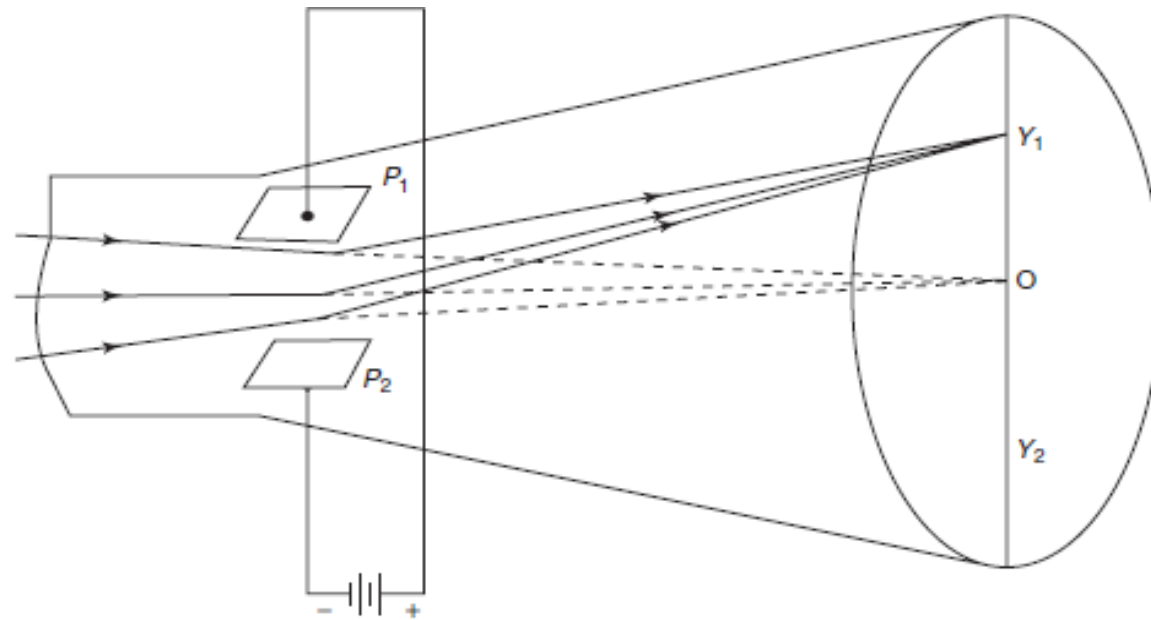

Figure 14-3(a) Deflecting system using parallel vertical plates

Deflection Systems:

- To deflect the beam horizontally, an alternating voltage is applied to the horizontal deflecting plates and the spot on the screen horizontally, as shown in Fig. 14-3(b).
- The electrons will focus at point X_2 . *By changing the polarity of voltage, the beam will focus at point X_1 . Thus, the horizontal movement is controlled along X_1OX_2 line.*

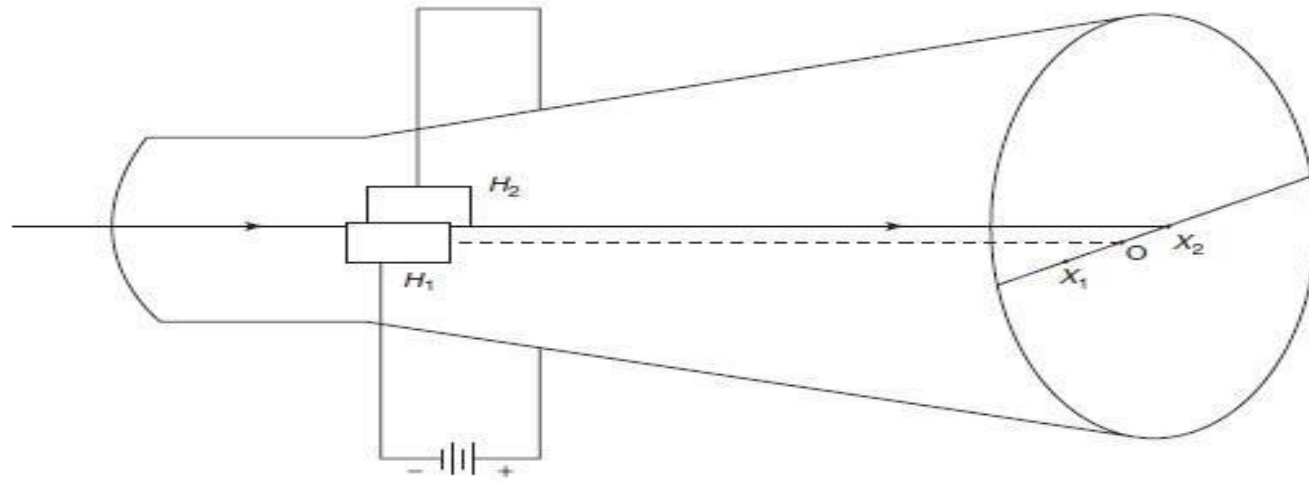

Figure 14-3(b) Deflecting system using parallel horizontal plate

Spot Beam Deflection Sensitivity:

The deflection sensitivity of a CRT is defined as the distance of the spot-beam deflection on the screen per unit voltage. If I_{total} is the total amount of deflection of the spot beam on the screen for the deflecting voltage V_d , as shown in Fig.14-4, the sensitivity can be expressed as:

$$S = \frac{I_{\text{total}}}{V_d} \quad (14-1)$$

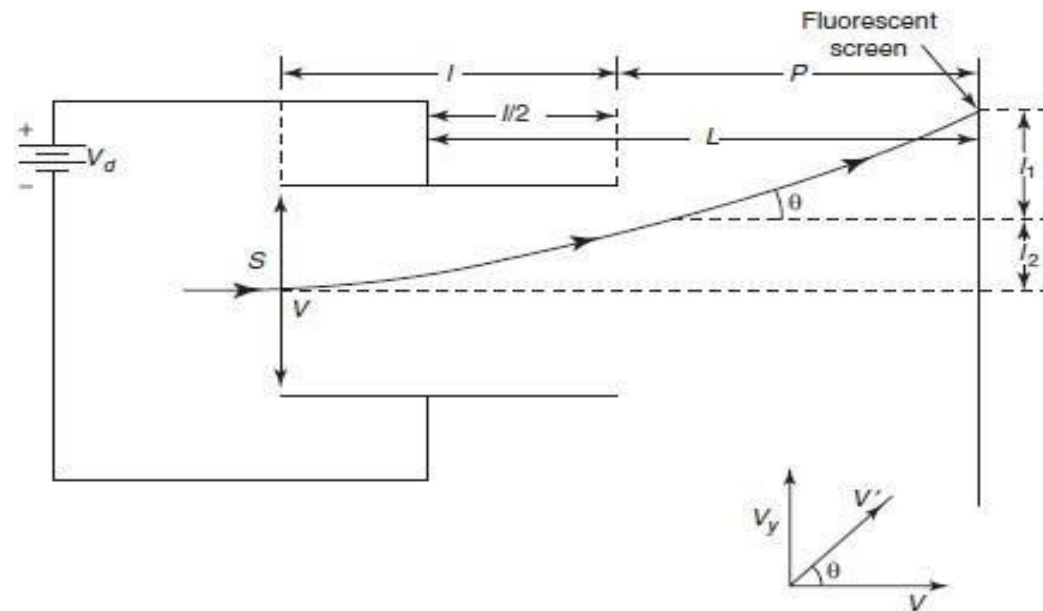

Figure 14-4 Schematic diagram of electrostatic deflection systems

Electrostatic Deflection:

Electrostatic Deflection

s = separation between deflecting plates

P = distance between the plate and screen S

l = length of each deflecting plate

V_d = deflecting voltage applied across the plates

m = mass of the electron

e = charge of the electron

v = velocity of the entering electron

V_a = accelerating anode voltage

Thus:

$$\frac{1}{2}mv^2 = eV_a \quad (14-2)$$

$$v^2 = \frac{2eV_a}{m} \quad (14-3)$$

Force exerted on the electron towards the positive deflecting plate is:

$$F \cdot s = eV_d$$

$$F = \frac{eV_d}{s} \quad (14-4)$$

Electrostatic Deflection:

$$mf = \frac{eV_d}{s}$$

Hence, acceleration is:

$$f = \frac{eV_d}{ms} \quad (14-5)$$

Time taken by the electron to move through the deflecting plates is:

$$t = \frac{l}{v}$$

Therefore, the upward velocity acquired by the emerging electron is:

$$v_y = ft$$

$$v_y = \frac{fl}{v}$$

$$v_y = \frac{fl}{v} = \frac{eV_d l}{sm v} \quad (14-6)$$

Electrostatic Deflection:

where, D is the distance traversed by an electron, u is the initial velocity, f is the acceleration of an electron, and t is the time taken.

As the electron is starting from rest, the initial velocity is zero, i.e., $u = 0$ and the distance travelled by the electron $D = l_2$.

Substituting this value of D in the expression for D , from the formula of mechanics, we get:

$$l_2 = \frac{1}{2} ft^2 \quad (14-7)$$

Substituting the value of t in Eq. (14-7) we get:

$$l_2 = \frac{1}{2} f \left(\frac{l}{v}\right)^2 = \frac{eV_d l}{2 sm} \left(\frac{l}{v}\right)^2 \quad (14-8)$$

$$\tan \theta = \frac{v_y}{v} = \frac{l_1}{P} \quad (14-9)$$

$$l_{\text{total}} = l_1 + l_2 = \frac{eV_d l}{smv^2} \left(\frac{l}{2} + P\right) \quad (14-10)$$

Here:

$$L = \left(\frac{l}{2} + P\right) \quad (14-11)$$

Electrostatic Deflection:

Substituting v^2 from Eq. (14-3) and L from Eq. (14-11) in Eq. (14-10) we have:

$$l_{\text{total}} = \frac{ILV_d}{2sV_a} \quad (14-12)$$

The deflection sensitivity of the CRT is, by definition:

$$S = \frac{l_{\text{total}}}{V_d} = \frac{IL}{2sV_a} \text{ m/V} \quad (14-13)$$

The deflection factor of the CRT is:

$$G = \frac{1}{S} = \frac{2sV_a}{IL} \text{ V/m} \quad (14-14)$$

Fluorescent Screen:

- Phosphor is used as screen material on the inner surface of a CRT. Phosphor absorbs the energy of the incident electrons. The spot of light is produced on the screen where the electron beam hits.
- The bombarding electrons striking the screen, release secondary emission electrons. These electrons are collected or trapped by an aqueous solution of graphite called —Aquadag|| which is connected to the second anode.
- Collection of the secondary electrons is necessary to keep the screen in a state of electrical equilibrium.
- The type of phosphor used, determines the color of the light spot. The brightest available phosphor isotope, P31, produces yellow–green light with relative luminance of 99.99%.

Display waveform on the screen:

- Figure 14-5(a) shows a sine wave applied to vertical deflecting plates and a repetitive ramp or saw-tooth applied to the horizontal plates.
- The ramp waveform at the horizontal plates causes the electron beam to be deflected horizontally across the screen.
- If the waveforms are perfectly synchronized then the exact sine wave applied to the vertical display appears on the CRO display screen.

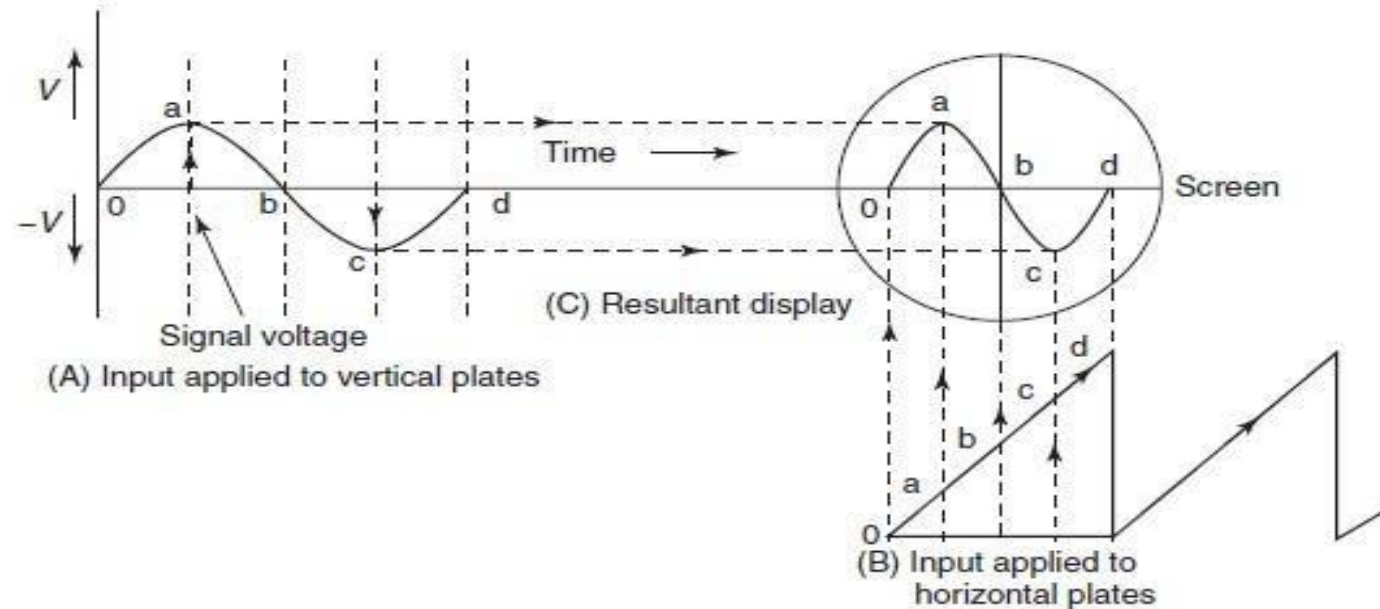

Figure 14-5(a) A typical display waveform on the screen

Triangular wave form

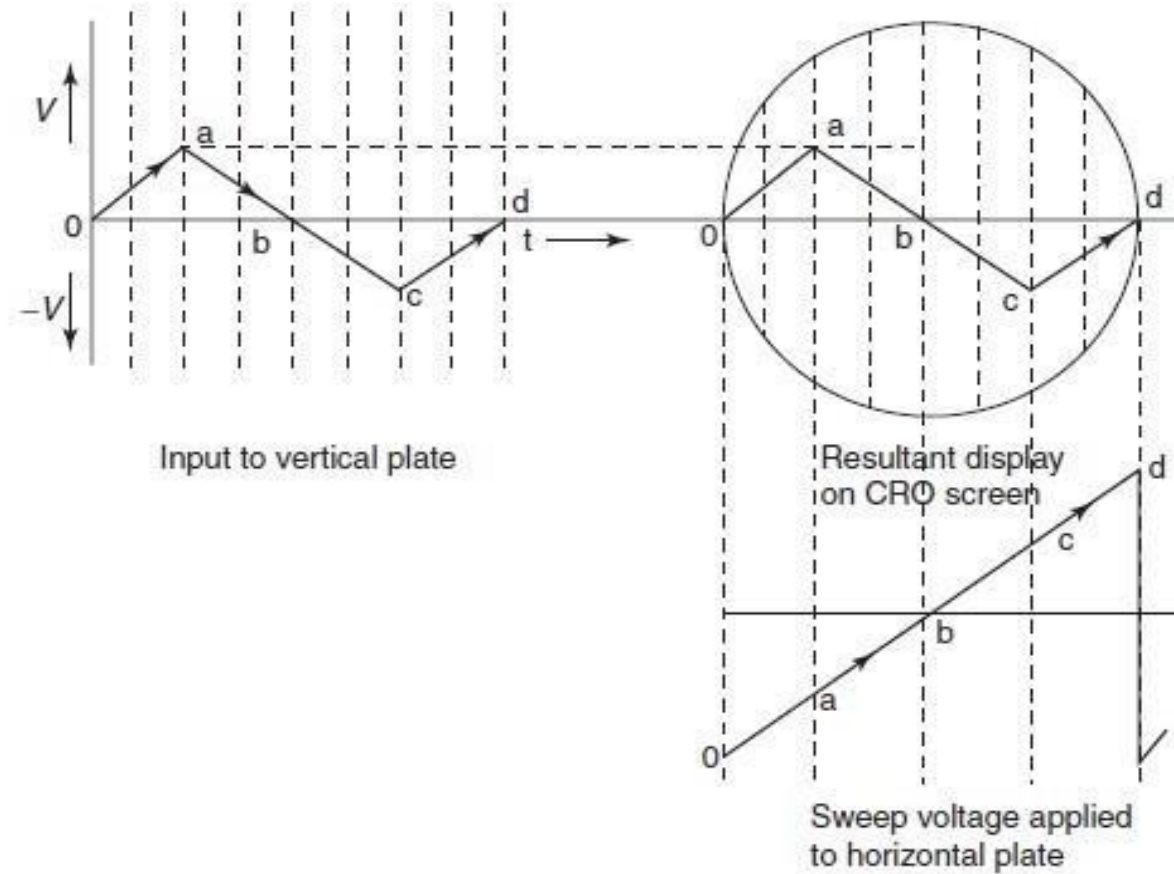

Figure 14-5(b) Triangular waveform input applied to the vertical deflecting plates of CRO

TIME-BASE GENERATORS

be accurately reproduced, the beam should have a constant horizontal velocity.

- As the beam velocity is a function of the deflecting voltage, the deflecting voltage must increase linearly with time.
- A voltage with such characteristics is called a ramp voltage. If the voltage decreases rapidly to zero—with the waveform repeatedly produced, as shown in Fig. 14-6—we observe a pattern which is generally called a saw-tooth waveform.
- The time taken to return to its initial value is known as fly back or return time.

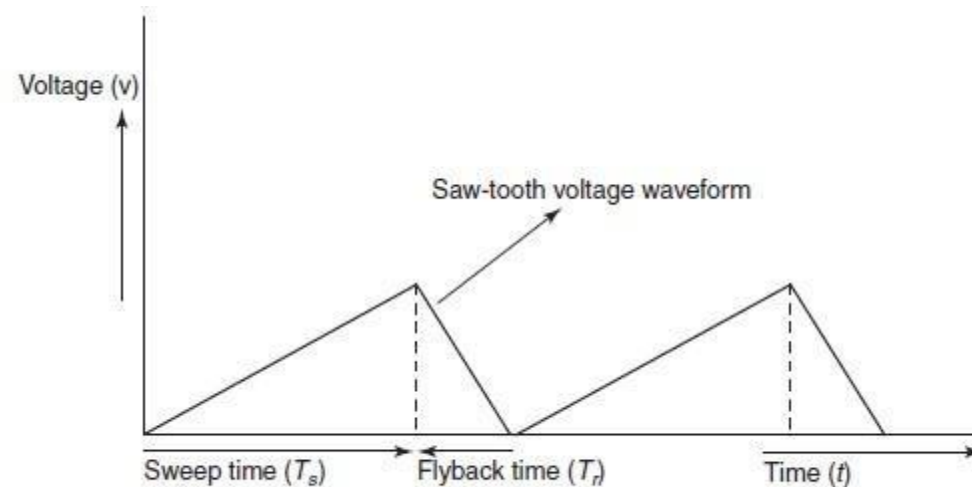

Figure 14-6 Typical saw-tooth waveform applied to the horizontal deflection plates

Simple saw-tooth generator & associated waveforms:

- The circuit shown in Fig. 14-7(a) is a simple sweep circuit, in which the capacitor C charges through the resistor R .
- The capacitor discharges periodically through the transistor T_1 , which causes the waveform shown in Fig. 14-7(b) to appear across the capacitor.
- The signal voltage, V_i which must be applied to the base of the transistor to turn it ON for short time intervals is also shown in Fig. 14-7(b).

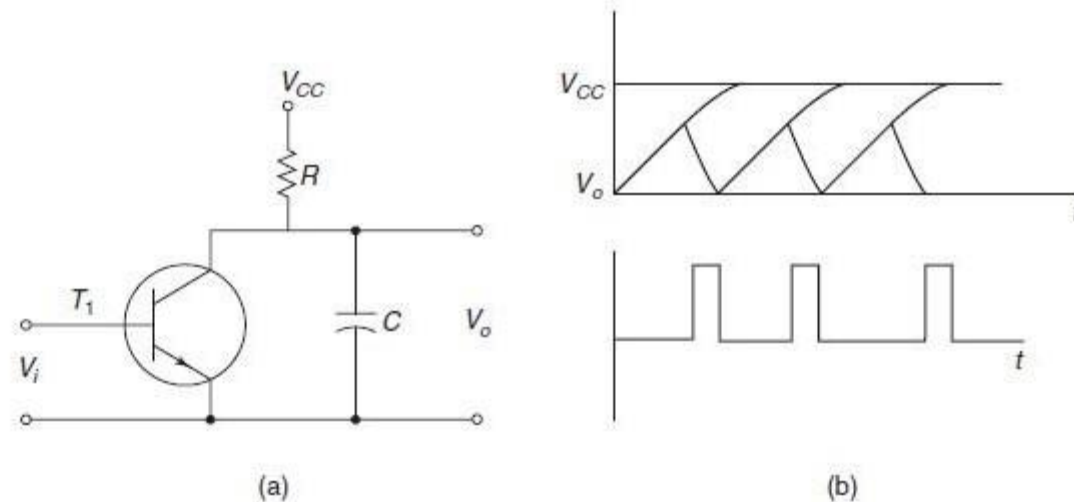

Figure 14-7: (a) simple saw-tooth generator (b) associated waveforms.

Time-base generator using UJT:

- The continuous sweep CRO uses the UJT as a time-base generator. When power is first applied to the UJT, it is in the OFF state and C_T charges exponentially through R_T .
- *The UJT emitter voltage V_E rises towards V_{BB} and V_E reaches the plate voltage V_P .*
- The emitter-to-base diode becomes forward biased and the UJT triggers ON. This provides a low resistance discharge path and the capacitor discharges rapidly.
- When the emitter voltage V_E reaches the minimum value rapidly, the UJT goes OFF. The capacitor recharges and the cycles repeat.

- To improve the sweep linearity, two separate voltage supplies are used; a low voltage supply for the UJT and a high voltage supply for the $RTCT$ circuit. This circuit is as shown in Fig. 14-7(c).
- *R_T is used for continuous control of frequency within a range and C_T is varied or changed in steps. They are sometimes known as timing resistor and timing capacitor.*

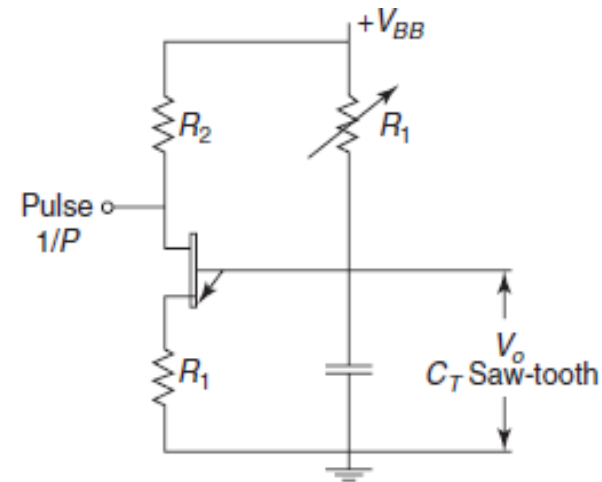

Figure 14-7 (c) Time-base generator using UJT

Oscilloscope Amplifiers:

- The purpose of an oscilloscope is to produce a faithful representation of the signals applied to its input terminals.
- Considerable attention has to be paid to the design of these amplifiers for this purpose. The oscillographic amplifiers can be classified into two major categories.
 - (i) AC-coupled amplifiers
 - (ii) DC-coupled amplifiers
- The low-cost oscilloscopes generally use ac-coupled amplifiers. The ac amplifiers, used in oscilloscopes, are required for laboratory purposes. The dc-coupled amplifiers are quite expensive. They
 - offer the advantage of responding to dc voltages, so it is possible to measure dc voltages as pure signals
 - and ac signals superimposed upon the dc signals.
- DC-coupled amplifiers have another advantage. They eliminate the problems of low-frequency phase shift and waveform distortion while observing low-frequency pulse train.
- The amplifiers can be classified according to bandwidth use also:
 - (i) Narrow-bandwidth amplifiers
 - (ii) Broad-bandwidth amplifiers

Vertical Amplifiers:

- Vertical amplifiers determines the sensitivity and bandwidth of an oscilloscope. Sensitivity, which is expressed in terms of V/cm of vertical deflection at the mid-band frequency.
- The gain of the vertical amplifier determines the smallest signal that the oscilloscope can satisfactorily measure by reproducing it on the CRT screen.
- The sensitivity of an oscilloscope is directly proportional to the gain of the vertical amplifier. So, as the gain increases the sensitivity also increases.
- The vertical sensitivity measures how much the electron beam will be deflected for a specified input signal. The CRT screen is covered with a plastic grid pattern called a graticule.
 - The spacing between the grids lines is typically 10 mm. Vertical sensitivity is generally expressed in volts per division.
- The vertical sensitivity of an oscilloscope measures the smallest deflection factor that can be selected with the rotary switch.

Frequency response:

- The bandwidth of an oscilloscope detects the range of frequencies that can be accurately reproduced on the CRT screen. The greater the bandwidth, the wider is the range of observed frequencies.
- The bandwidth of an oscilloscope is the range of frequencies over which the gain of the vertical amplifier stays within 3 db of the mid-band frequency gain, as shown in Fig. 14-8.
- Rise time is defined as the time required for the edge to rise from 10–90% of its maximum amplitude. An approximate relation is given as follows:

$$t_r \times BW = 0.35$$

where, t_r is the rise time in seconds and BW is the band width in Hertz.

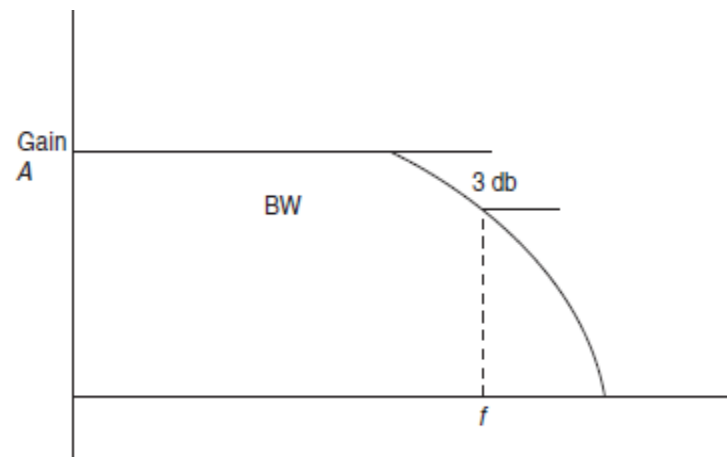

Figure 14-8 Frequency response graphs

MEASUREMENTS USING THE CATHODE-RAY OSCILLOSCOPE:

1) Measurement of Frequency:

Time-base Measurement

Time-base measurement helps to determine the frequency of a time-varying signal displayed on the CRT screen. If a time interval t has x complete cycles, then the time period of the signal is:

$$T = \frac{t}{x}$$

or,

$$f = \frac{1}{T} = \frac{x}{t}$$

Hence, the frequency is determined.

Measurement Using Lissajous Figures

The application of sinusoidal waves at the same time to the deflection plates produces various patterns. These patterns, are generated on the basis of the relative amplitudes, frequencies and phases of the different waveforms and are known as Lissajous figures.

Figure 14-9 shows the Lissajous figure as a form of ellipse.

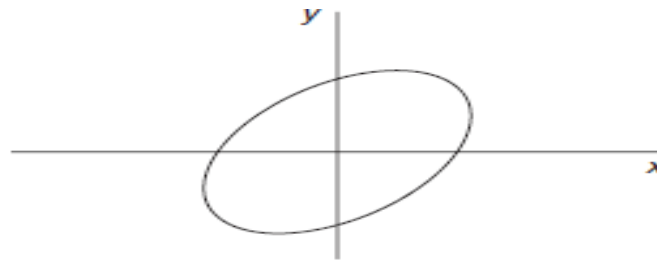

Figure 14-9 Lissajous figure as a form of ellipse

Frequency can be determined from:

$$\frac{f_v}{f_h} = \frac{\text{Number of horizontal tangencies}}{\text{Number of vertical tangencies}}$$

where, f_v and f_h are the frequencies of the vertical and the horizontal signals, respectively.

• 2) Measurement of Phase:

The phase difference of two different waveforms displayed on the CRT screen can be found from the time axis. Two sinusoidal signals of time period T are in the same phase at time t_1 and t_2 respectively, and the phase difference between them is expressed as:

$$\varphi = \frac{2\pi}{T} (t_1 - t_2) \quad (14-16)$$

Figure 14-10 shows the phase difference of two different waveforms.

• 3 Measurement of Phase Using Lissajous Figures:

Lissajous figures are used to measure the phase difference between two sinusoidal voltages of the same amplitude and frequency. The signals are applied simultaneously to the horizontal and vertical deflection plates. The values of the deflection voltages are given by:

$$v_y = A \sin (\omega t + \varphi) \quad (14-17)$$

and

$$v_x = A \sin \omega t \quad (14-18)$$

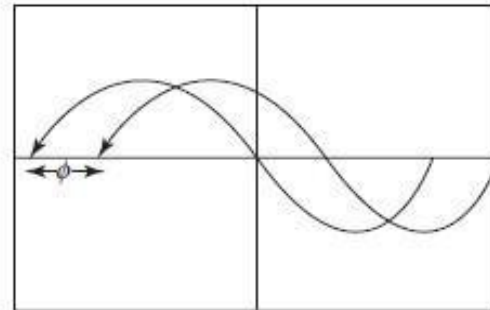

Figure 14-10 Measurement of phase difference

Measurement of Phase Using Lissajous

Fig The values of the deflection voltages are given by:

$$v_y = A \sin (\omega t + \varphi)$$

$$v_x = A \sin \omega t$$

Here A is the amplitude, ω is the angular frequency and φ is the phase angle by which v_y leads v_x . Eq. (14-17) can be expanded as:

$$v_y = A \sin \omega t \cos \varphi + A \cos \omega t \sin \varphi \quad (14-19)$$

Equation (14-18) yields:

$$A \cos \omega t = \sqrt{A^2 - v_x^2} \quad (14-20)$$

Substituting the sine and cosine terms from Eqs. (14-17) and (14-18) in Eq. (14-19), we get:

$$v_y = A \sin \omega t \cos \varphi + \sqrt{A^2 - v_x^2} \sin \varphi$$

$$v_y = v_x \cos \varphi + \sqrt{A^2 - v_x^2} \sin \varphi$$

$$v_y - v_x \cos \varphi = \sqrt{A^2 - v_x^2} \sin \varphi$$

$$(v_y - v_x \cos \varphi)^2 = (A^2 - v_x^2) \sin^2 \varphi$$

$$v_y^2 - 2v_x \cos \varphi v_y + v_x^2 \cos^2 \varphi = A^2 \sin^2 \varphi - v_x^2 \sin^2 \varphi$$

$$v_y^2 - 2v_x \cos \varphi v_y + v_x^2 \cos^2 \varphi - v_x^2 \sin^2 \varphi = A^2 \sin^2 \varphi$$

$$v_y^2 - 2v_x \cos \varphi v_y + v_x^2 (\cos^2 \varphi + \sin^2 \varphi) = A^2 \sin^2 \varphi$$

$$v_y^2 - 2v_x \cos \varphi v_y + v_x^2 = A^2 \sin^2 \varphi$$

$$v_x^2 + v_y^2 - 2v_x v_y \cos \varphi = A^2 \sin^2 \varphi. \quad (14.21)$$

The Lissajous figure is thus, an ellipse represented by Eq. (14-21). The ellipse is depicted in Fig. 14-9.

Measurement of Phase Using Lissajous Figures:

Case I: When $\varphi = 0^\circ$, $\cos \varphi = 1$, $\sin \varphi = 0$

Then, Eq. (14-21) reduces to:

$$\begin{aligned}v_x^2 + v_y^2 - 2v_x v_y &= 0 \\(v_x - v_y)^2 &= 0 \\v_x &= v_y\end{aligned}\tag{14-22}$$

Equation (14-22) represents a straight line with slope 45° , i.e., $m = 1$. The straight line diagram is shown in Fig. 14-11(a).

Case II: When $0 < \varphi < 90$, $\varphi = 45^\circ$, $\cos \varphi = \frac{1}{\sqrt{2}}$, $\sin \varphi = \frac{1}{\sqrt{2}}$

Then Eq. (14-21) reduces to:

$$v_x^2 + v_y^2 - \sqrt{2}v_x v_y = \frac{A^2}{2}\tag{14-23}$$

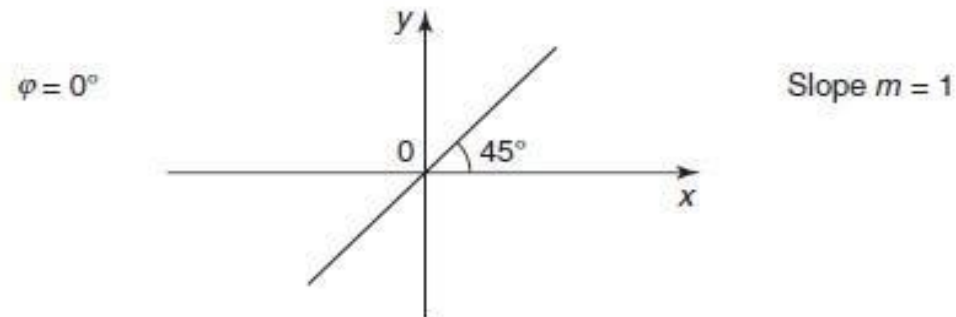

Figure 14-11(a) Lissajous figure at $\varphi = 0^\circ$ is a straight line with slope $m = 1$

Measurement of Phase Using Lissajous Figures:

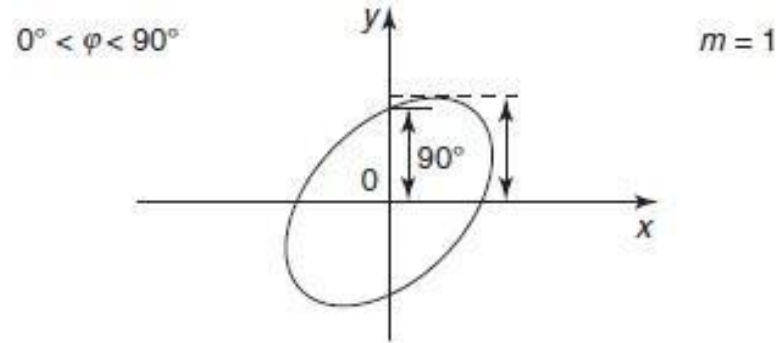

Figure 14-11(b) Lissajous figure at $0^\circ < \varphi < 90^\circ$ takes the shape of an ellipse

Equation (14-11) represents an ellipse, as shown in Fig. 14-11(b).

Case III: When $\varphi = 90^\circ$, $\cos \varphi = 0$, $\sin \varphi = 1$

Then Eq. (14-21) reduces to:

$$v_x^2 + v_y^2 = A^2 \quad (14-24)$$

Equation (14-24) represents a circle shown in Fig. 14-12.

Case IV: When $90 < \varphi < 180$; say $\varphi = 135^\circ$,

$$\cos \varphi = -\frac{1}{\sqrt{2}}, \quad \sin \varphi = \frac{1}{\sqrt{2}}$$

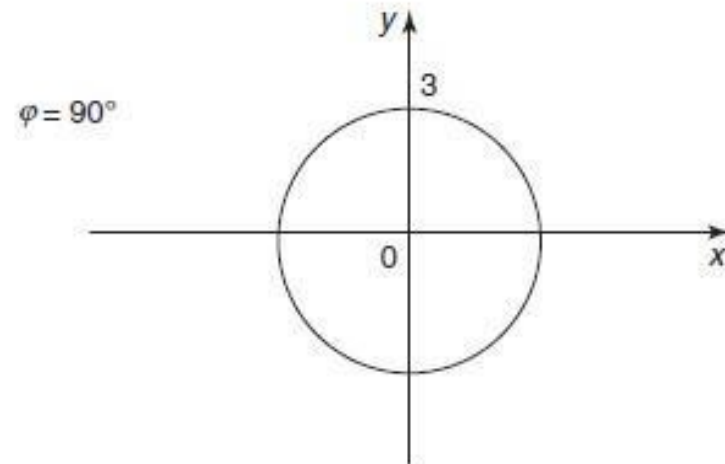

Figure 14-12 Lissajous figure at $\varphi = 90^\circ$: it forms a circle

Measurement of Phase Using Lissajous Figures:

Then Eq. (14-21) reduces to:

$$v_x^2 + v_y^2 + \sqrt{2}v_x v_y = \frac{A^2}{2} \quad (14-25)$$

Equation (14-25) represents an ellipse shown in Fig. 14-13.

Case V: $\varphi = 180^\circ$, $\cos \varphi = -1$, $\sin \varphi = 0$

Then Eq. (14-21) reduces to:

$$\begin{aligned} v_x^2 + v_y^2 + 2v_x v_y &= 0 \\ (v_x + v_y)^2 &= 0 \\ v_x &= -v_y \end{aligned} \quad (14-26)$$

Equation (14-26) represents a straight line with slope $m = -1$; a slope of 45° in the negative direction of the x -axis, as shown in Fig. (14-14).

The maximum y -displacement, A , and the vertical displacement, V_y , at time $t = 0$ can be measured from the vertical scale of the CRO. Putting $t = 0$ in Eq. (14-17), we get:

$$v_{y0} = A \sin \varphi \quad (14-27)$$

$$\sin \varphi = \frac{v_{y0}}{A} \quad (14-28)$$

Thus, the phase angle can be found from Eq. (14-28) using any form of the Lissajous figure.

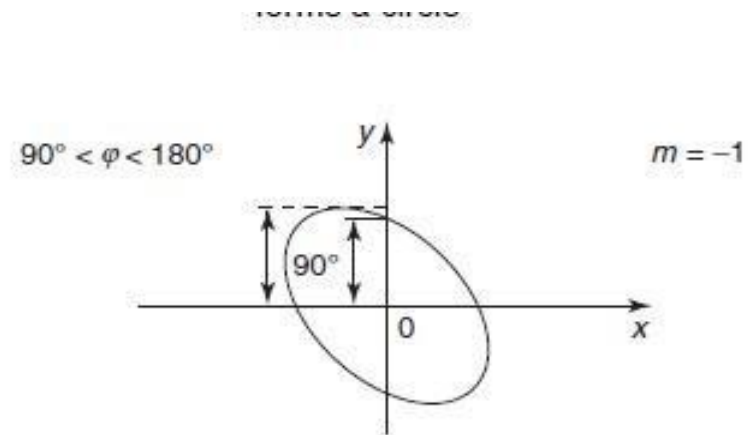

Figure 14-13 Lissajous figure when $90 < \varphi < 180$

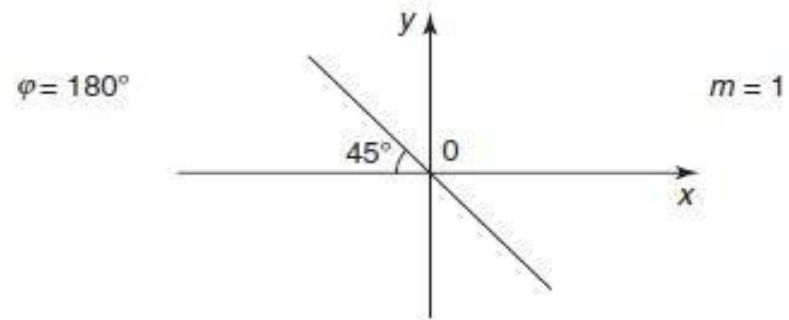

Figure 14-14 Lissajous figure at $\varphi = 180^\circ$ with negative slope $m = -1$

Applications of the Sweep Frequency

1. Sweep frequency generators are used to display the response curve of the various stages of frequency of television or radio receivers.
2. Sweep frequency generators can be used to determine the characteristics of a device over a wide continuous range of frequencies.

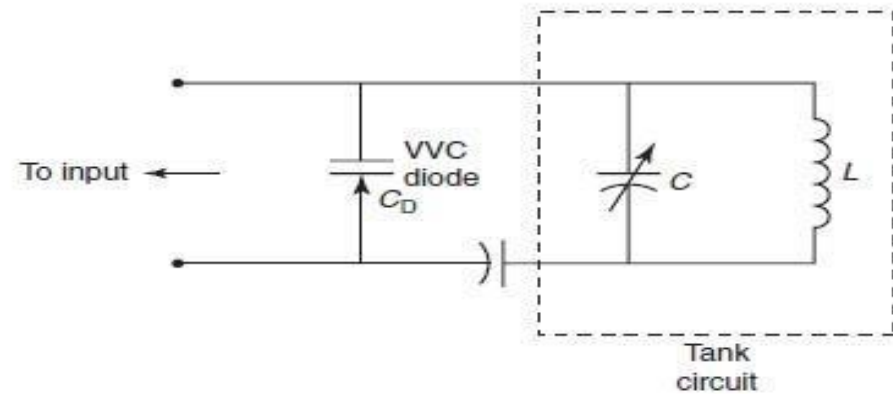

Figure 14-16 Oscillator tank circuit

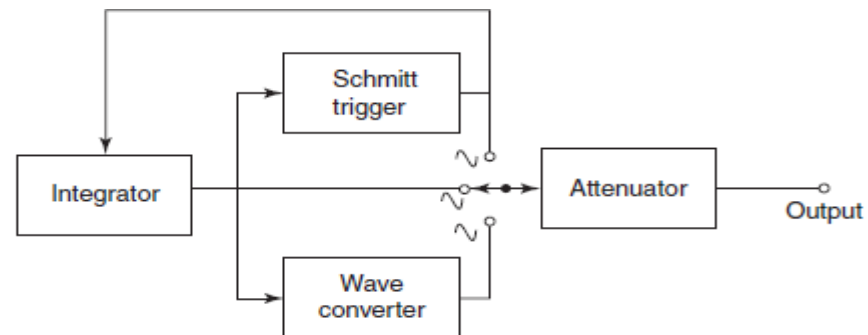

Figure 14-17 Block diagram of a function generator

Lissajous' Figures

- Lissajous' figure can be displayed by applying two a.c. signals simultaneously to the X-plates and Y-plates of an oscilloscope.
- As the frequency, amplitude and phase difference are altered, different patterns are seen on the screen of the CRO.

Lissajous' Figures

Same amplitude but different frequencies

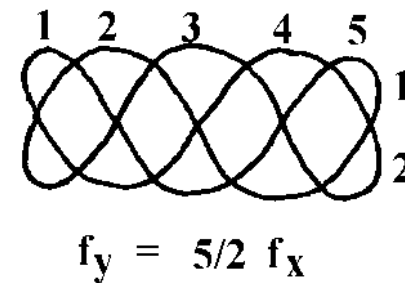
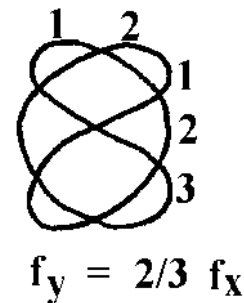
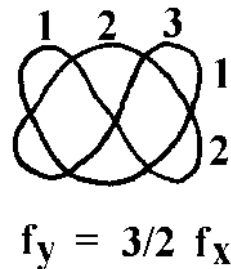
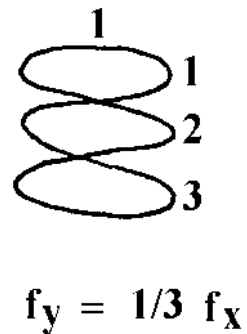
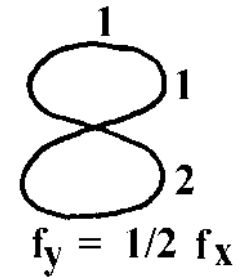
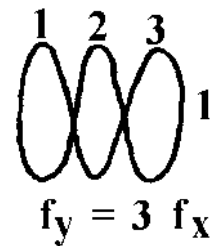
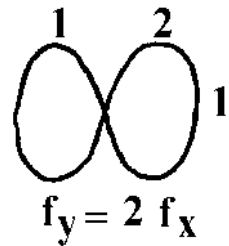
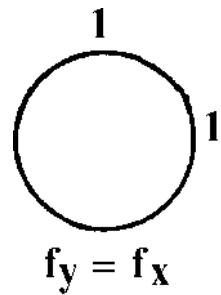

- Combined effects: approximation
 - Serial delay
 - The frequency response of a probe, being a combination of several random filter poles near each other in frequency, is Gaussian.

$$T_{rise_composite} = \left(T_1^2 + T_2^2 + \dots + T_N^2 \right)^{\frac{1}{2}}$$

- Rise time is 10-90% rise time
 - When figuring a composite rise time, the squares of 10-90% rise times add
- Manufacturer usually quotes 3-db bandwidth F_{3db}
 - approximations $T_{10-90} = 0.338/F_{3dB}$ for **each stage** (obtained by simulation)

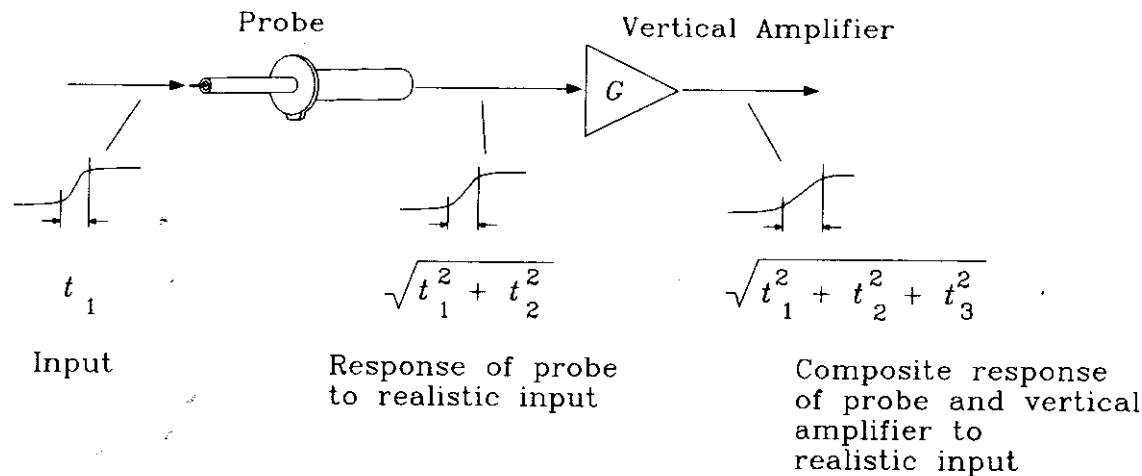

Example:

e:

Given: Bandwidth of probe and scope = 300 MHz

$$T_{\text{signal}} = 2.0 \text{ ns}$$

$$T_{\text{scope}} = 0.338 / 300 \text{ MHz} = 1.1 \text{ ns}$$

$$T_{\text{probe}} = 0.338 / 300 \text{ MHz} = 1.1 \text{ ns}$$

$$T_{\text{displayed}} = (1.1^2 + 1.1^2 + 2.0^2)^{1/2}$$
$$= 2.5 \text{ ns}$$

For the same system, if $T_{\text{displayed}} = 2.2 \text{ ns}$, what is the actual rise time?

$$T_{\text{actual}} = (2.2^2 - 1.1^2 - 1.1^2)^{1/2}$$
$$= 1.6 \text{ ns}$$

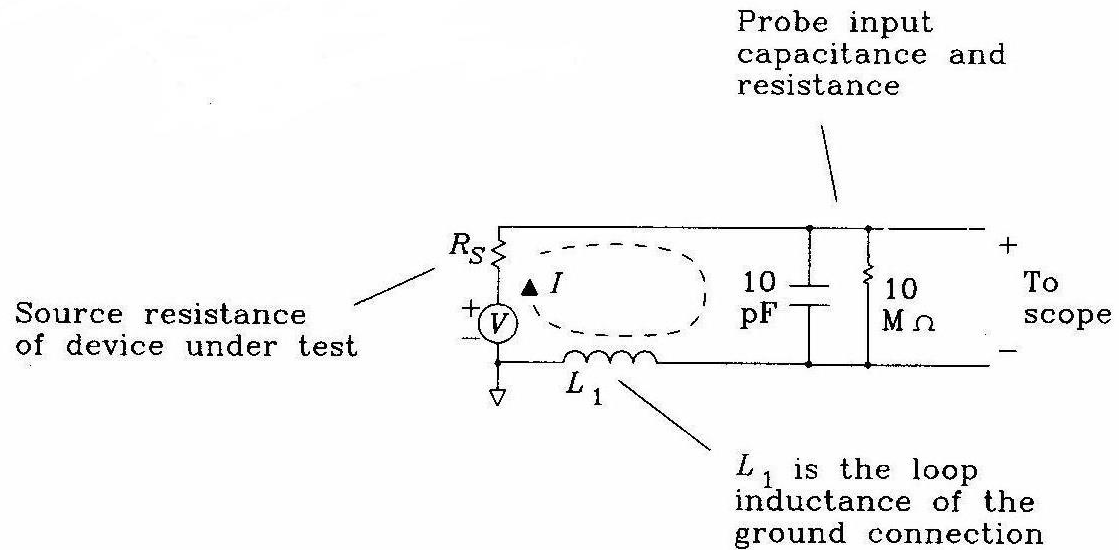

- Typically, 3 inches (of 0.02" Gauge wire loop) wire on ground plane equals to (approx) 200 nH
- Input $C = 10\text{pf}$
- $T_{LC} = (LC)^{1/2} = 1.4\text{ns}$
- $T_{10-90} = 3.4 T_{LC} = 4.8\text{ns}$
- This will slow down the response a lot.

Estimation of circuit

- Output resistance of source combine with the loop inductance & input capacitance is a ringing circuit.
- Where

$$Q \approx \frac{(L/C)^{1/2}}{R_s}$$

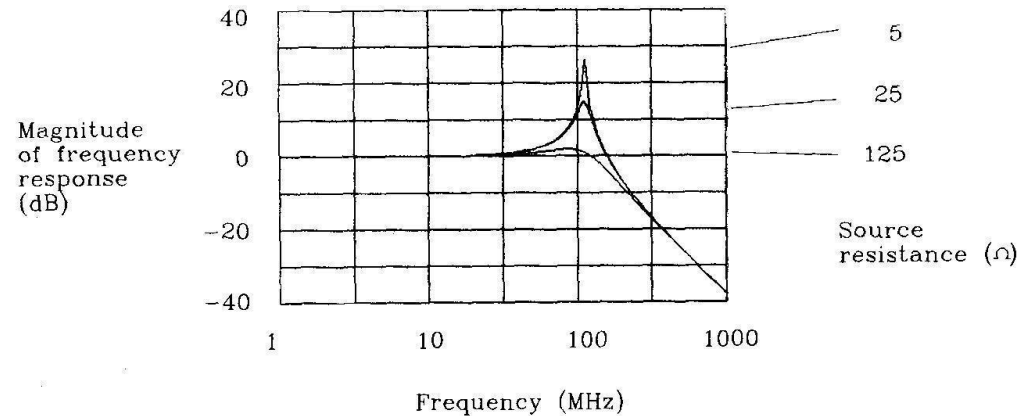

Probe ground loop is
1 in. \times 3 in.
Probe input impedance
is 10 pF, 10 M Ω

- Q is the ratio of energy stored in the loop to energy lost per radian during resonant decay.
- Fast digital signals will exhibit overshoots. We need the right R_s to damp the circuit. On the other hand, it slows down the response.

- **Impact:** probe having ground wires, when using to view very fast signals from low-impedance source, will display artificial ringing and overshoot.
- A 3" ground wire used with a 10 pf probe induces a 2.8 ns 10-90% rise time. In addition, the response will ring when driven from a low-impedance source.

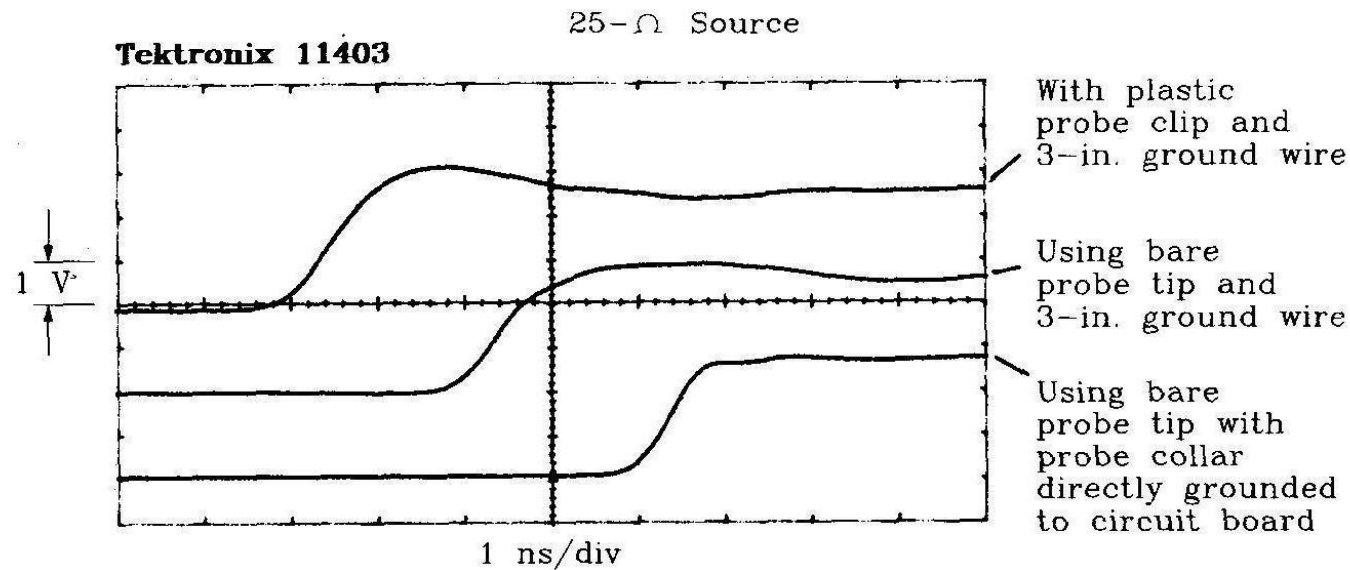

Traces have been artificially delayed to improve the appearance of the figure

Ringing induced in a 1.7-pF probe by a 3-in. ground wire when viewing a 25- Ω source.

Remedy Try to minimize the earth loop

wire

- Grounding the probe close to the signal source

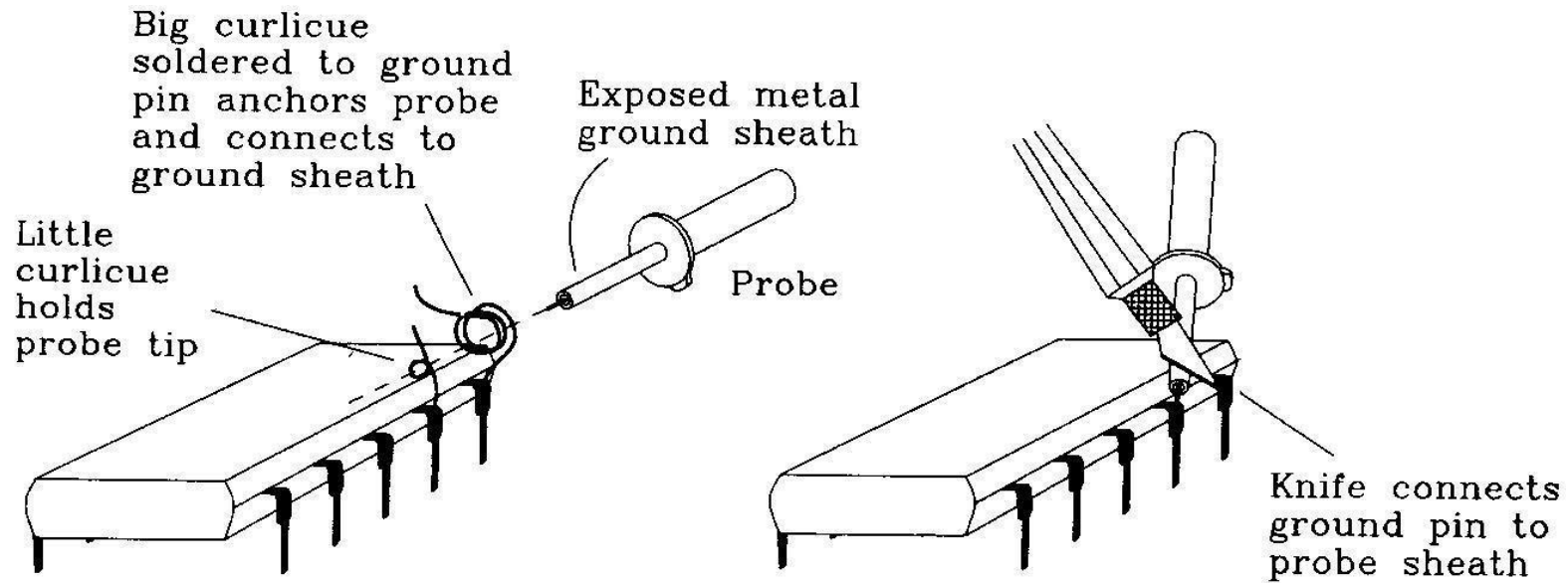

Both methods reduce the inductance of the probe ground loop

Methods for grounding a probe tip near a signal under test.

Spurious signal pickup from probe ground loops

- Mutual inductance between Signal loop A and Loop B

$$L_M = 5.08 \frac{A_1 A_2}{r^3}$$

where

- A1 (A2) = areas of loops
 - r = separation of loops
 - Refer to figure for values.
 - In this example, $L_M = 0.17\text{nH}$
- Typically IC outputs
 - $\max \text{d}I/\text{d}t = 7.0 * 10^7 \text{ A/s}$

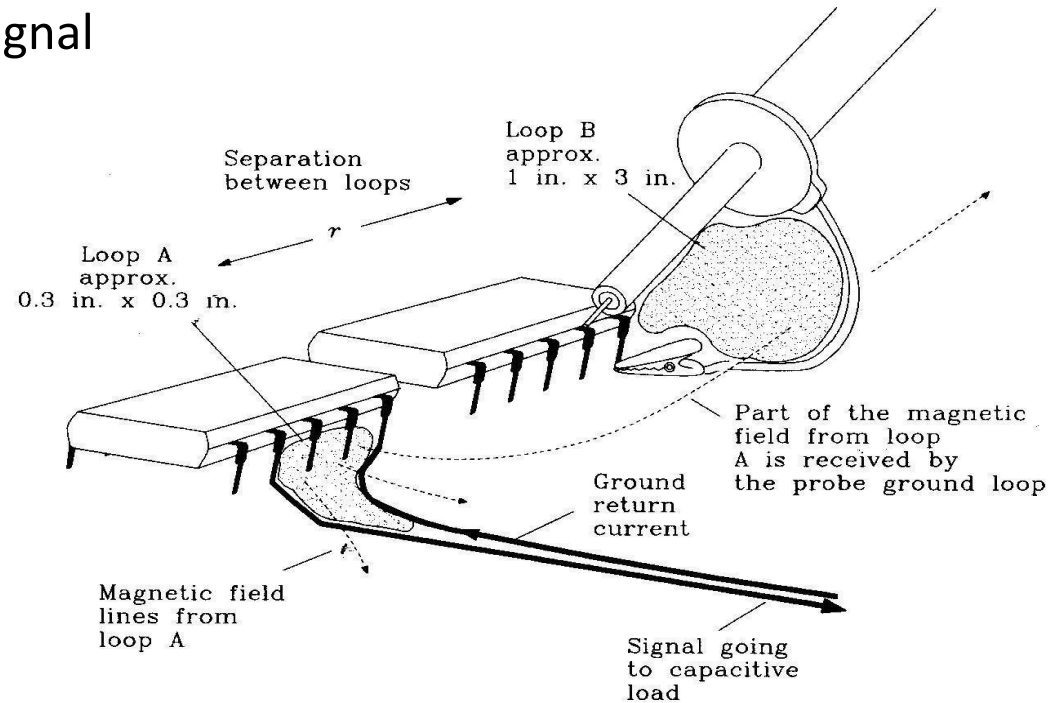

A probe ground loop picks up spurious noise voltages.

$$V_{noise} = L_M \frac{dI}{dt} = (0.17\text{nh})(7.0 \times 10^7 \text{ V/s}) = 12\text{mV}$$

- 12mV is not a lot until you have a 32-bit bus; must try to minimize loop area

How probes load down a circuit

- Common experience
 - Circuit works when probe is inserted. It fails when probe is removed.
- Effect is due to loading effect, impedance of the circuit has changed. The frequency response of the circuit will change as a result.
- To minimize the effect, the probe should have no more than 10% effect on the circuit under test.
 - E.g. the probe impedance must be 10 times higher than the source impedance of the circuit under test.

An experiment showing the probe loading effect

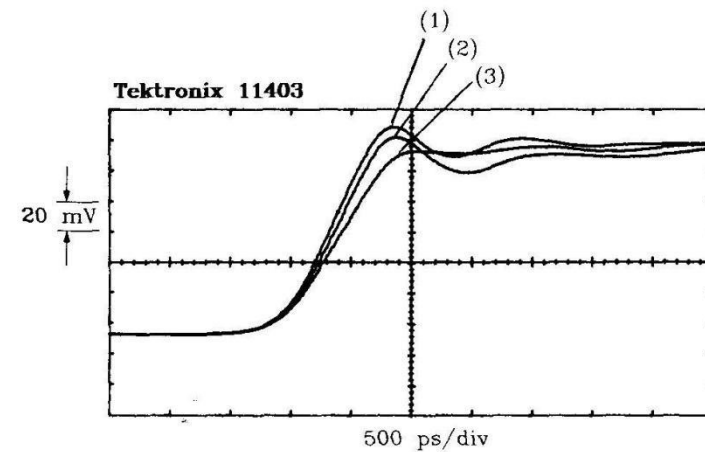
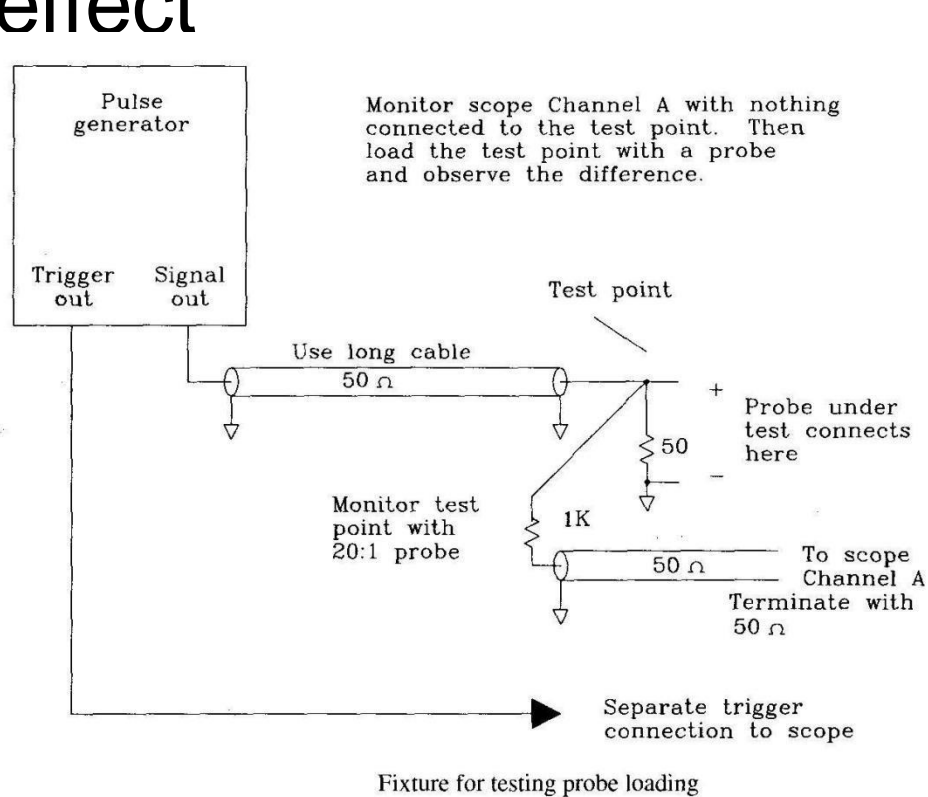

- (1) No load
- (2) P6137 10-pF probe using 6-in. ground wire
- (3) P6137 10-pF probe with collar directly grounded using small knife blade

A 10 pf probe loading a 25 ohm circuit

- A 10 pf probe looks like 100 ohms to a 3 ns rising edge
- Less probe capacitance means less circuit loading and better measurements.

Special probing fixtures

- Typical probes with 10 pf inputs and one 3" to 6" ground wire are not good enough for anything with faster than 2ns rising edges
- Three possible techniques to attack this problem
 - Shop built 21:1 probe
 - Fixtures for a low-inductance ground loop
 - Embedded Fixtures for probing

Advantages of the 21:1 probe

- High input impedance = 1050 ohm
- Shunt capacitance of a 0.25 W 1K resistor is around 0.5 pf, that is small enough.
 - But when the frequency is really high, this shunt capacitance may create extra loading to the signal source.
- Very fast rise time, the signal source is equivalent to connecting to a 1K load, the L/R rise time degradation is much smaller than connecting the signal to a standard 10 pf probe.

Avoiding pickup from probe shield Currents

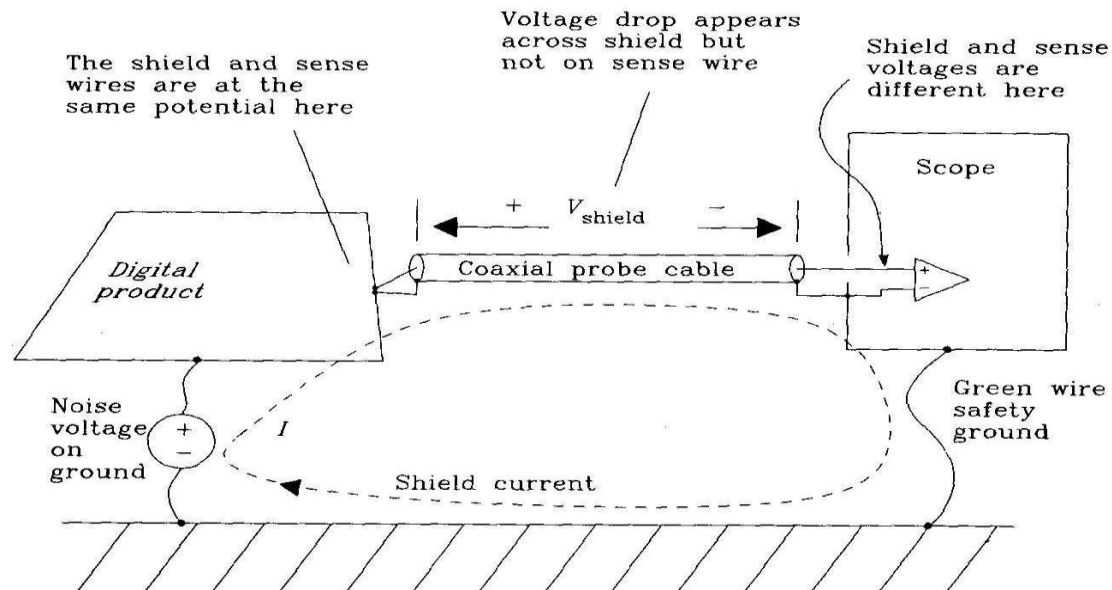

- Shield is also part of a current path.
- Voltage difference exists between logic ground and scope chassis; current will flow.
- This “shield current * shield resistance R_{shield} ” will produce noise V_{shield}

- V_{Shield} is proportional to shield resistance, not to shield inductance because the shield and the centre conductor are magnetically coupled. Inductive voltage appear on both signal and shield wires.
- To observe V_{Shield}
 - Connect your scope tip and ground together
 - Move the probe near a working circuit without touching anything. At this point you see only the magnetic pickup from your probe sense loop
 - Cover the end of the probe with Al foil, shorting the tip directly to the probe's metallic ground shield. This reduces the magnetic pickup to near zero.
 - Now touch the shorted probe to the logic ground. You should see only the V_{Shield}

- Use a 1:1 probe to avoid the 10 time magnification when using 10X probe
- Use a differential probe arrangement

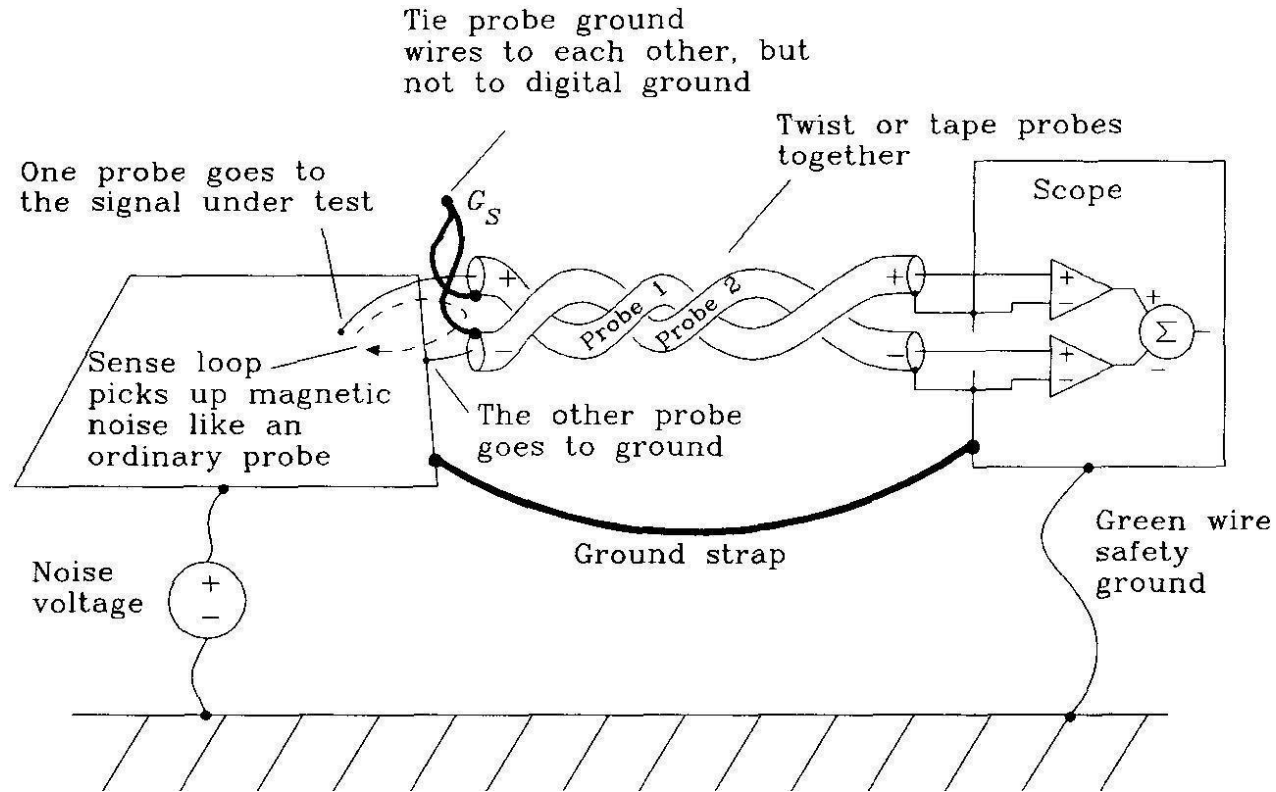

- No jitter at trigger point due to repeated syn with positive-going edge.
 - This could be misleading
- For proper measurement, trigger with the source clock
 - The jitter is around half of the previous one.
 - If source clock is not available, trigger on the source data signal point A or B (where is minimal jitter)

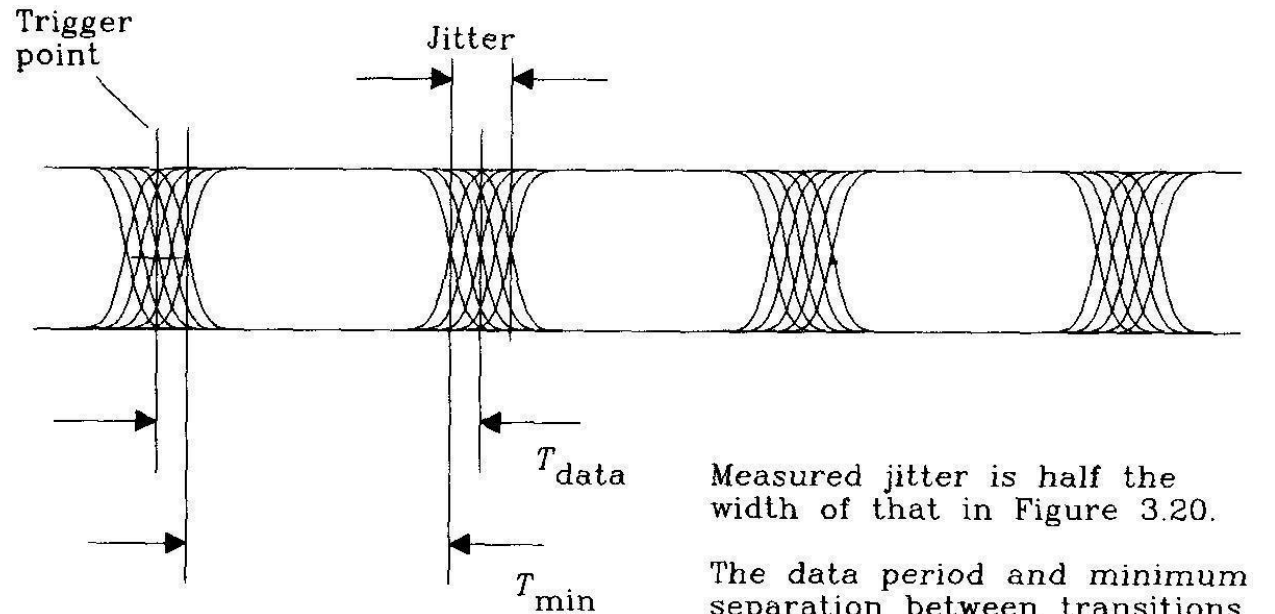

Measured jitter is half the width of that in Figure 3.20.

The data period and minimum separation between transitions are the same as in Figure 3.20.

Slowing Down the System clock

- Not easy to observe high speed digital signals which include ringing, crosstalk and other noises.
- Trigger on a slower clock (divide the system clock) allows better observations because it allows all signals to decay before starting the next cycle.
- It will help debugging timing problems.

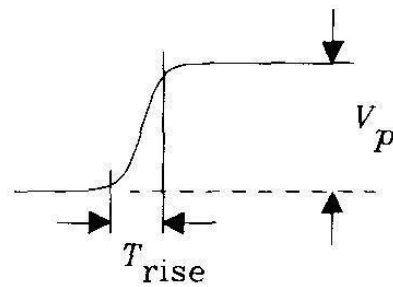
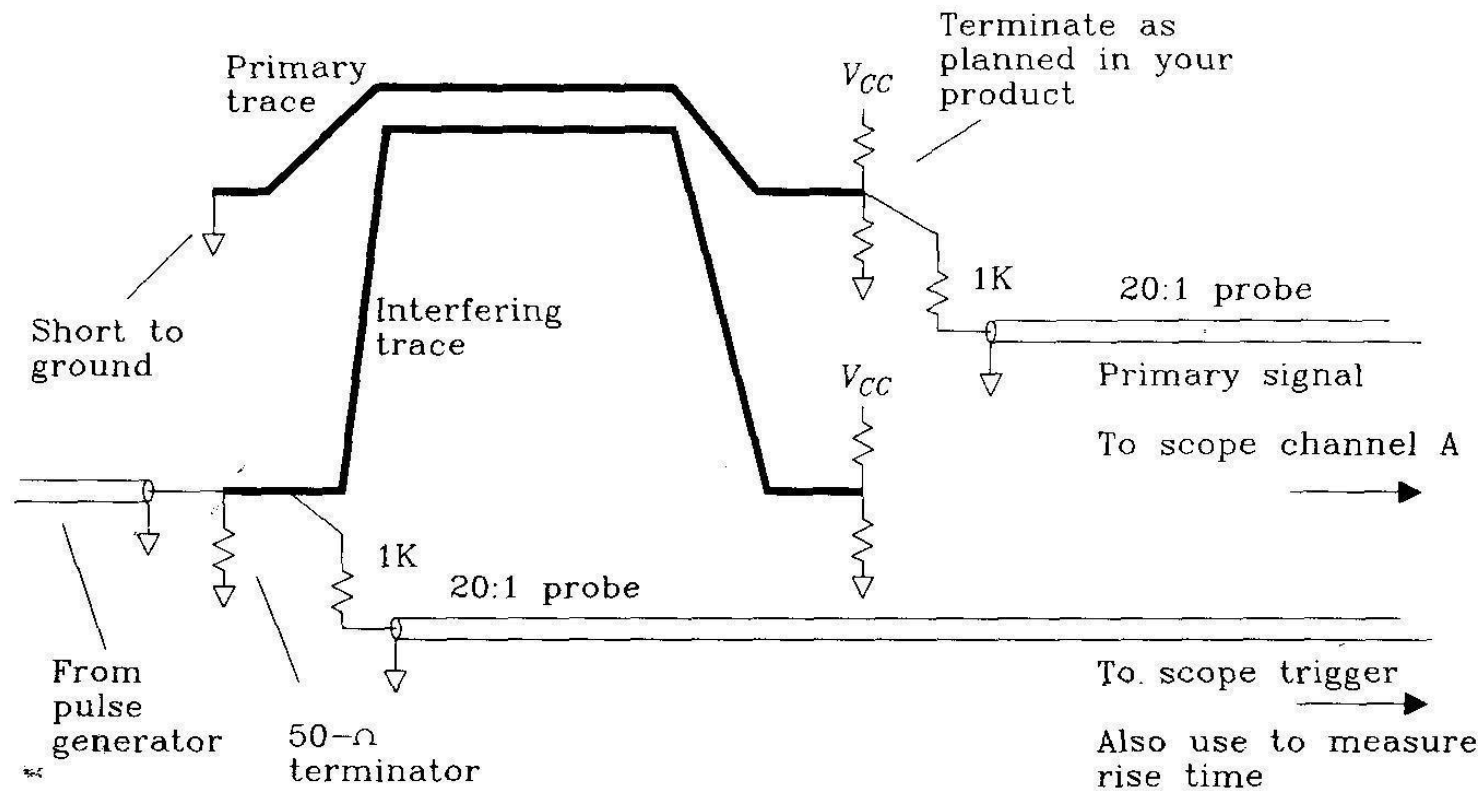

$$\left(\frac{dV}{dt}\right)_{\max} = \frac{V_p}{T_{\text{rise}}}$$

Measuring crosstalk between two signal traces.

- Try one of the followings to observe the cross talk
 - Turn off primary signal (or short the bus drivers)
 - Varying the possible noise source signal (e.g. signal patterns for the bus)
 - Compare signals when noise source is on and off
 - Take photos with the suspected noise source ON and source OFF.
 - The difference is the crosstalk
 - Generating artificial crosstalk
 - Turn off, disabled, short the driving end of the primary signal. Induce a step edge of known rise time on the interfering trace and measure the induced voltage.
 - Useful technique when measuring empty board without components.

POINTS TO REMEMBER:

- 1. CRO is used to study waveforms.
- 2. CRT is the main component of a CRO.
- 3. Prosperous P31 is used for the fluorescent screen of a CRO.
- 4. A CRO has the following components:
 - (a) Electron gun
 - (b) Deflecting system
 - (c) Florescent screen
- 5. Lissajous figures are used to measure frequency and phase of the waves under study.
- 6. A time-base generator produces saw-tooth voltage.
- 7. An oscilloscope amplifier is used to provide a faithful representation of input signal applied to its input terminals.

IMPORTANT FORMULAE:

1. The deflection sensitivity of the CRT is:

$$S = \frac{l_{\text{total}}}{V_d} = \frac{IL}{2sV_a} \text{ m/V}$$

2. The deflection factor of the CRT is:

$$G = \frac{1}{S} = \frac{2sV_a}{IL} \text{ V/m}$$

3. Phase angle is given by:

$$\varphi = \frac{2\pi}{T}(t_1 - t_2)$$

4. Lissajous equation is given by:

$$v_x^2 + v_y^2 - 2v_x v_y \cos \varphi = A^2 \sin^2 \varphi$$

SPECIAL PURPOSE OSCILLOSCOPES

DUAL BEAM OSCILLOSCOPE

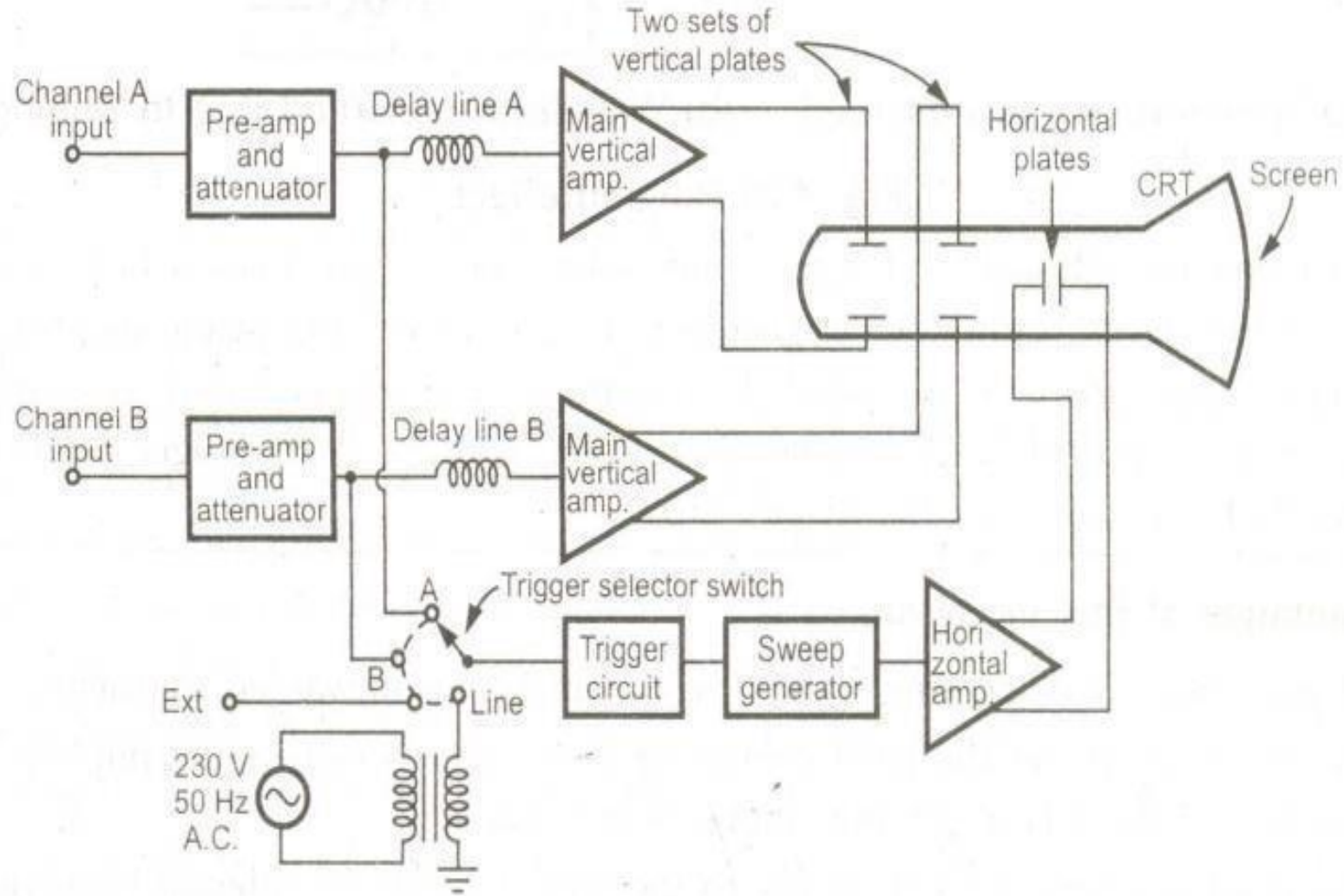

- This is the Another method of studying two voltages simultaneously on the screen is to use special cathode ray
- Tube having two separate electron guns generating two separate beam Each electron beam has its
- Own vertical deflection plates.
- But the two beams are deflected horizontally by the common set of horizontal plate\ The time base circuit may be same or different. Such an oscilloscope is called **Dual Beam Oscilloscope**.
- The oscilloscope has two vertical deflection plates and two separate channels A and B for the two
- separate input signals. Each channel consists of a preamplifier and an attenuator. A delay line,
- main vertical amplifier and a set of vertical deflection plates together forms a single channel. There is a single set of horizontal plates and single time base circuit.

- The sweep generator drives the horizontal amplifier which in turn drives the plates. The horizontal plates sweep both the beams across the screen at the same rate. The sweep generator can be triggered internally by the channel A signal or channel B signal. Similarly it can also be triggered from an external signal or line frequency signal. This is possible with the help of trigger selector switch, a front panel control.

- Such an oscilloscope may have separate time base circuit for separate channel. This allows

- different sweep rates for the two channels but increases the size and

- weight of the oscilloscope.

DUAL TRACE OSCILLOSCOPE

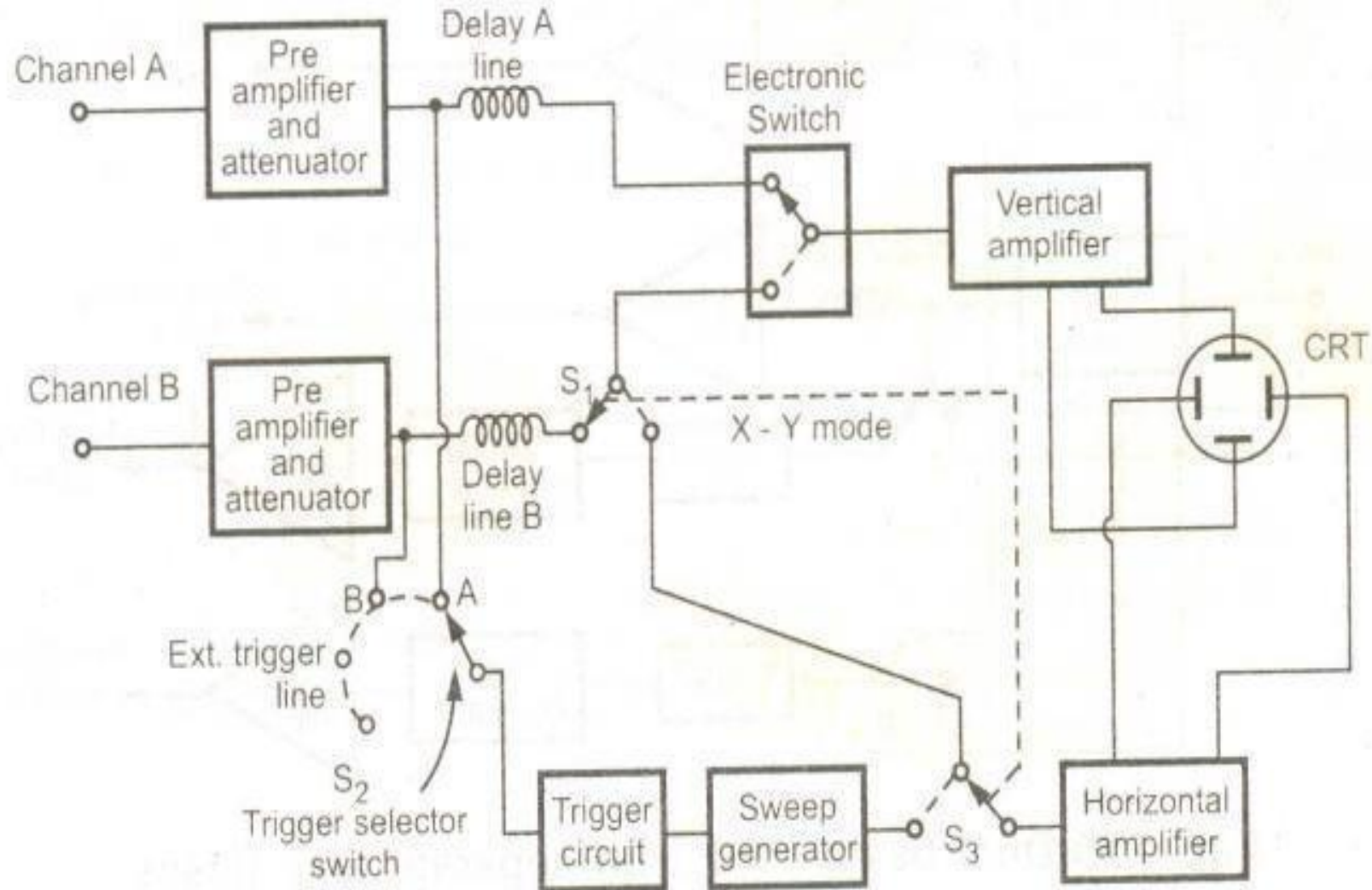

- The comparison of two or more voltages is very much ,necessary in the analysis and study of many electronic circuits and systems.
- This is possible by using more than one oscilloscope but in such a case it is difficult to trigger the sweep of each oscilloscope precisely at the same time.
- A common and less costly method to solve this problem is to use dual trace or multi trace oscilloscopes.
- In this method, the same electron beam is used to generate two traces which can be deflected from two independent vertical sources.
- The methods are used to generate two independent traces which the alternate sweep method and other is chop method.

DIGITAL STORAGE OSCILLOSCOPE

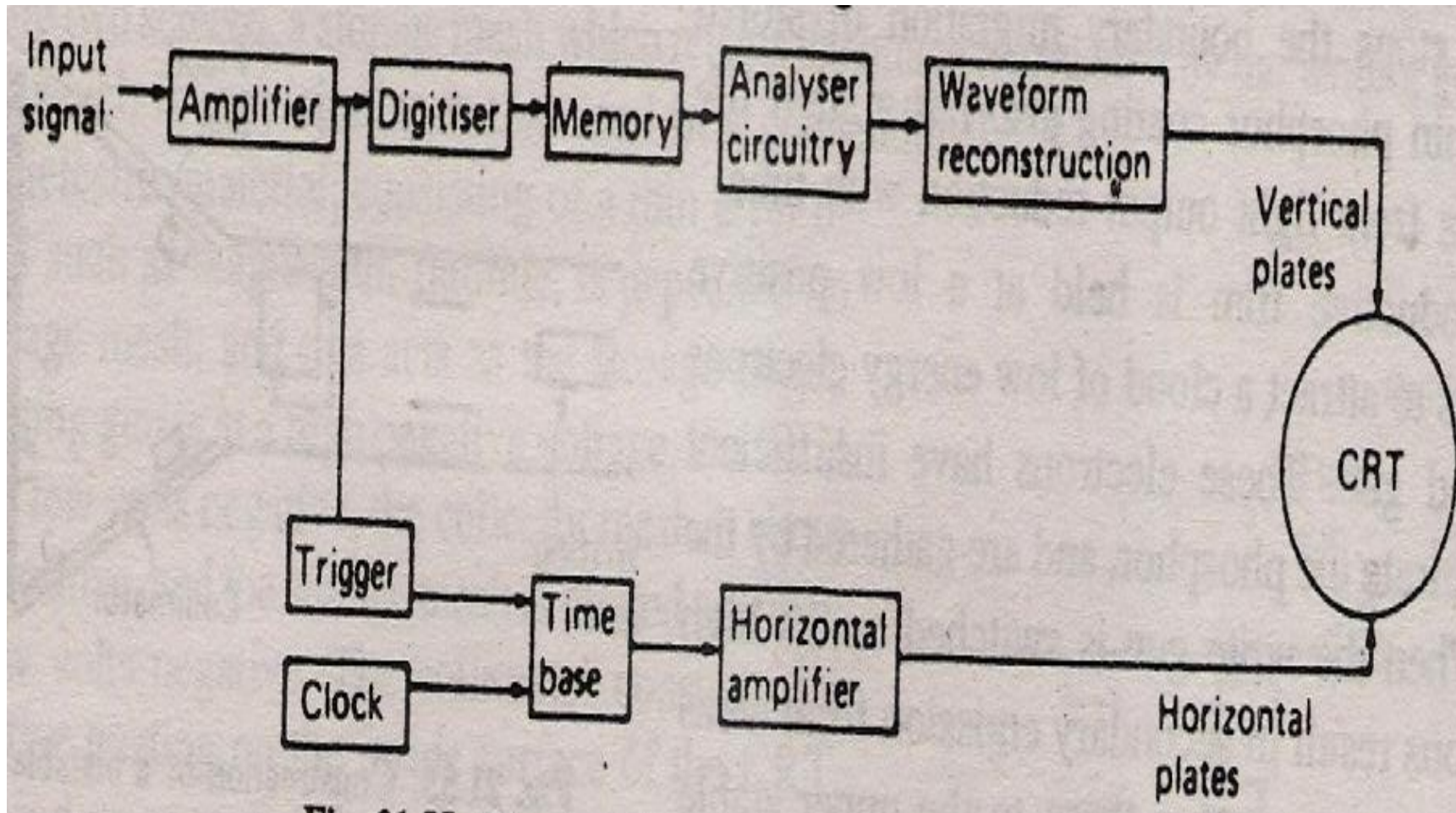

- The input signal is digitized and stored in memory in digital form.
- In this state it is capable of being analyzed to produce a variety of different information.
- To view the display on the CRT the data from memory is reconstructed in analog form.
- The analog input voltage is sampled at adjustable rates (up to 100,000 samples per
- second) and data points are read onto the memory.

- If the memory is read out rapidly and repetitively, an input event which is a single shot transient becomes a repetitive or continuous waveform that can be observed easily on an ordinary scope (not a storage scope).
- The digital memory also may be read directly (without going through DAC) to, say, a computer where a stored program can manipulate the data in almost any way desired

COMPLETE BLOCK DIAGRAM OF DSO

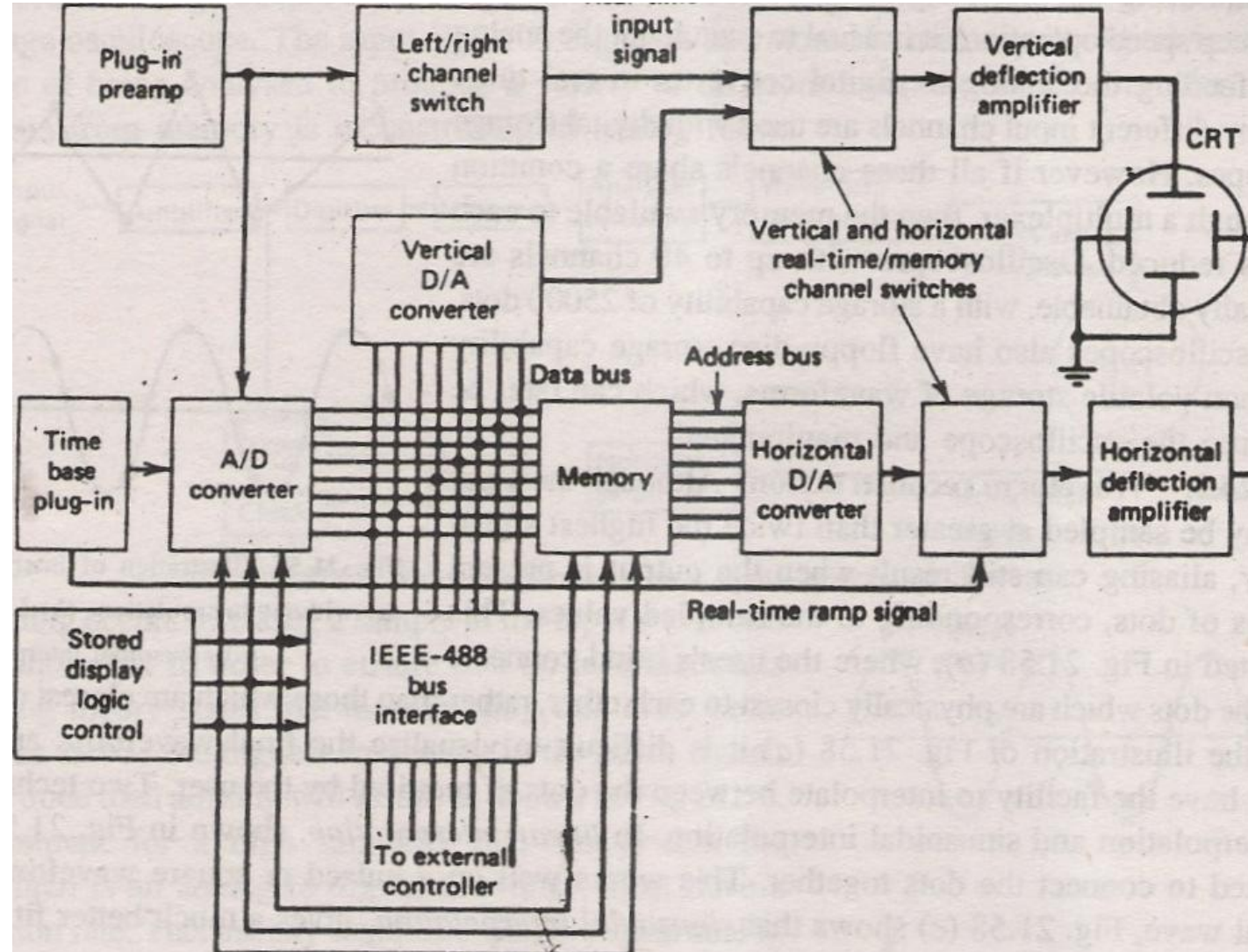

SAMPLING OSCILLOSCOPE

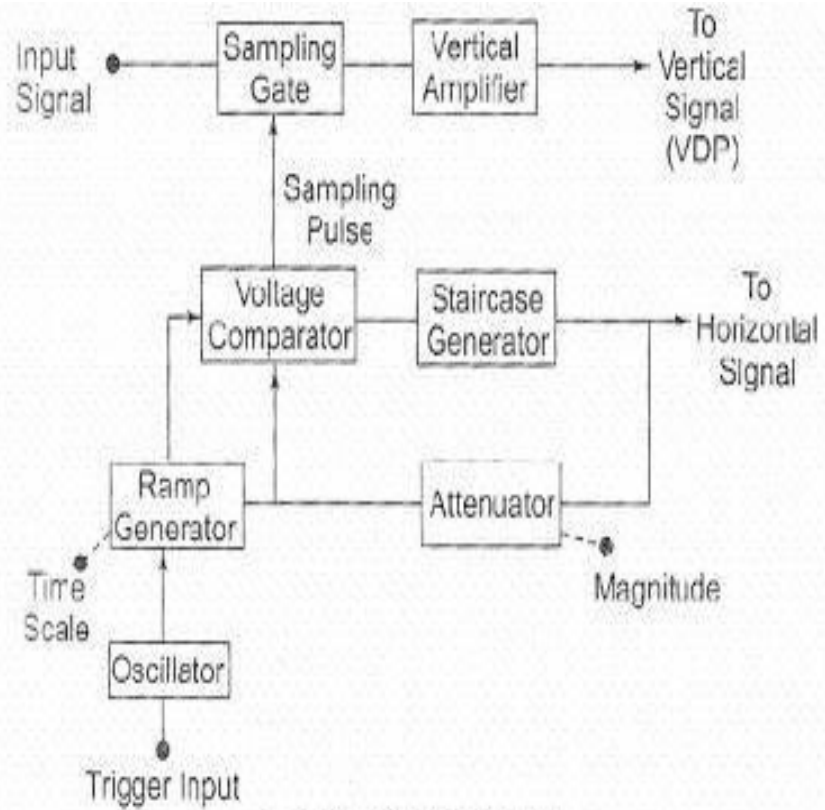

fig 4.1 Sampling Oscilloscope

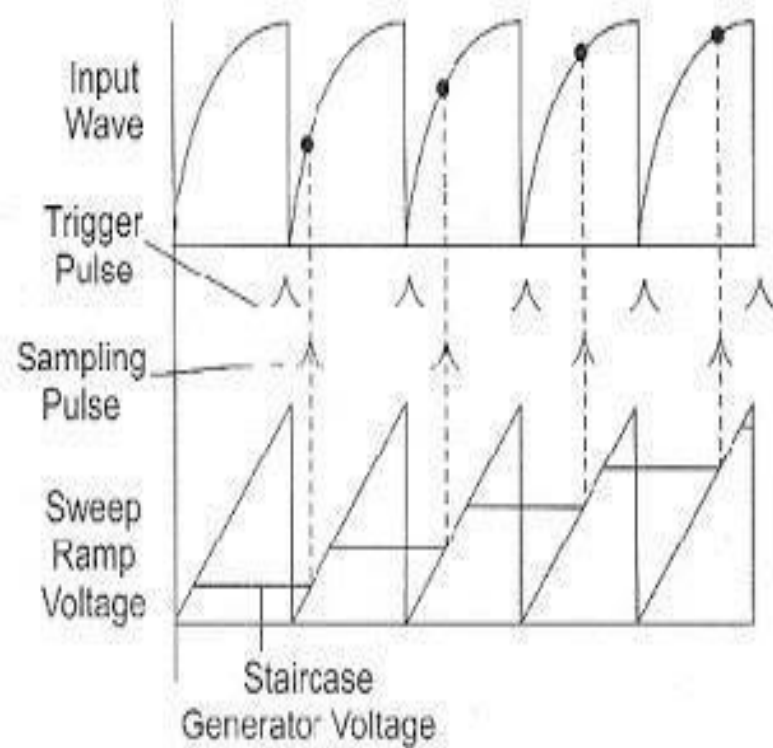

fig 4.2 Various Wave Forms at each block of oscilloscope.

- An ordinary oscilloscope has a B.W. of 10 MHz the HF performance can be improved by means of sampling the input waveform and reconstructing its shape from the sample, i.e. the signal to be observed is sampled and after a few cycles sampling point is advanced and another sample is taken.
- The shape of the wave form is reconstructed by joining the sample levels together. The sampling frequency may be as low as 1/10th of the input signal frequency (if the input signal frequency is 100 MHz, the bandwidth of the CRO vertical amplifier can be as low as 10 MHz). As many as 1000 samples are used to reconstruct the original waveform.

- The input is applied to the sampling gate. The input waveform is sampled whenever a sampling pulse opens the sampling gate.
- The sampling must be synchronized with the input signal frequency.
- The signal is delayed in the vertical amplifier, allowing the horizontal sweep to be initiated by the input signal.
- At the beginning of each sampling cycle, the trigger pulse activates an oscillator and a linear ramp voltage is generated.

- This ramp voltage is applied to a voltage comparator which compares the ramp voltage to a staircase generate-When the two voltages are equal in amplitude, the staircase advances one step and a sampling pulse is generated, which opens the sampling gate for a sample of input voltage.
- The resolution of the final image depends upon the size of the steps of the staircase generator. The smaller the size of the steps the larger the number of samples and higher the resolution of the image.

UNIT-4
TRANSDUCERS

INTRODUCTION OF TRANSDUCERS

- A transducer is a device that convert one form of energy to other form. It converts the measurand to a usable electrical signal.
- In other word it is a device that is capable of converting the physical quantity into a proportional electrical quantity such as voltage or current.

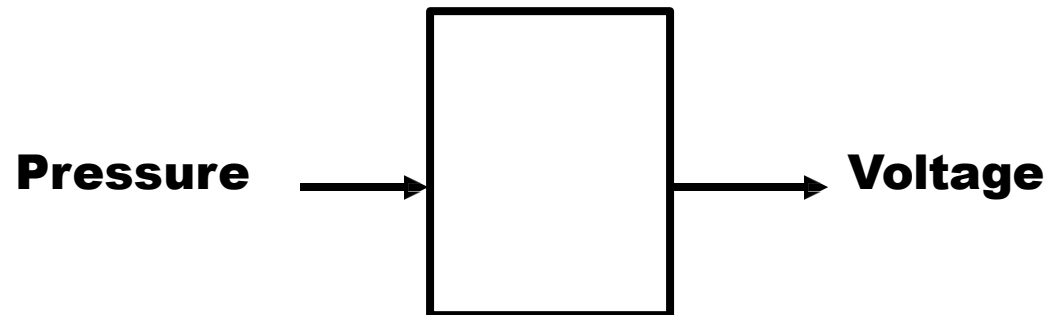

BLOCK DIAGRAM OF TRANSDUCERS

- Transducer contains two parts that are closely related to each other i.e. the sensing element and transduction element.
- The sensing element is called as the sensor. It is device producing measurable response to change in physical conditions.
- The transduction element convert the sensor output to suitable electrical form.

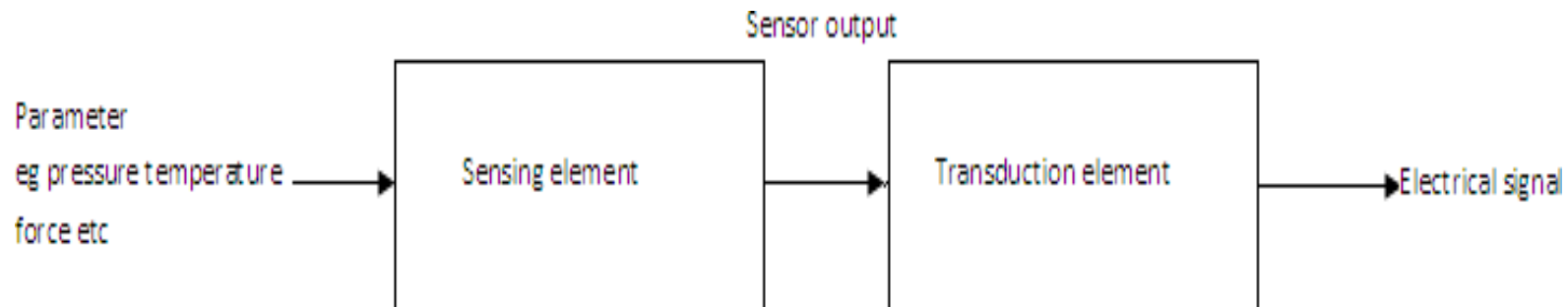

CHARACTERISTICS OF TRANSDUCERS

1. Ruggedness
2. Linearity
3. Repeatability
4. Accuracy
5. High stability and reliability
6. Speed of response
7. Sensitivity
8. Small size

TRANSDUCERS SELECTION FACTORS

- 1. Operating Principle:** The transducer are many times selected on the basis of operating principle used by them. The operating principle used may be resistive, inductive, capacitive , optoelectronic, piezo electric etc.
- 2. Sensitivity:** The transducer must be sensitive enough to produce detectable output.
- 3. Operating Range:** The transducer should maintain the range requirement and have a good resolution over the entire range.
- 4. Accuracy:** High accuracy is assured.
- 5. Cross sensitivity:** It has to be taken into account when measuring mechanical quantities. There are situation where the actual quantity is being measured is in one plane and the transducer is subjected to variation in another plan.
- 6. Errors:** The transducer should maintain the expected input-output relationship as described by the transfer function so as to avoid errors.

Contd.

7. **Transient and frequency response :** The transducer should meet the desired time domain specification like peak overshoot, rise time, setting time and small dynamic error.
8. **Loading Effects:** The transducer should have a high input impedance and low output impedance to avoid loading effects.
9. **Environmental Compatibility:** It should be assured that the transducer selected to work under specified environmental conditions maintains its input- output relationship and does not break down.
10. **Insensitivity to unwanted signals:** The transducer should be minimally sensitive to unwanted signals and highly sensitive to desired signals.

CLASSIFICATION OF TRANSDUCERS

The transducers can be classified as:

- I. Active and passive transducers.
- II. Analog and digital transducers.
- III. On the basis of transduction principle used.
- IV. Primary and secondary transducer
- V. Transducers and inverse transducers.

ACTIVE AND PASSIVE TRANSDUCERS

- **Active transducers :**

- These transducers do not need any external source of power for their operation. Therefore they are also called as self generating type transducers.

- I. The active transducer are self generating devices which operate under the energy conversion principle.
- II. As the output of active transducers we get an equivalent electrical output signal e.g. temperature or strain to electric potential, without any external source of energy being used.

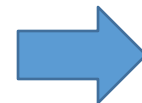

Piezoelectric Transducer

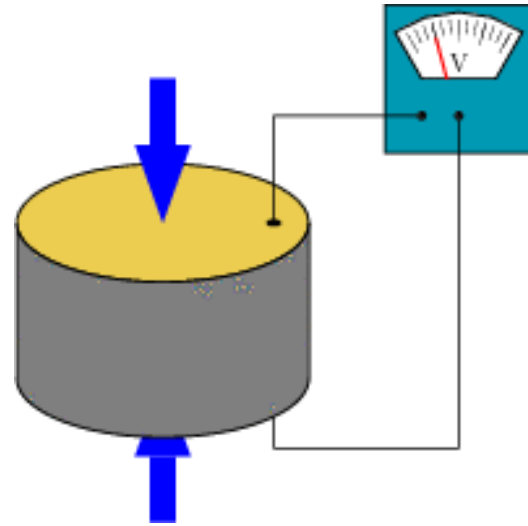

CLASSIFICATION OF ACTIVE TRANSDUCERS

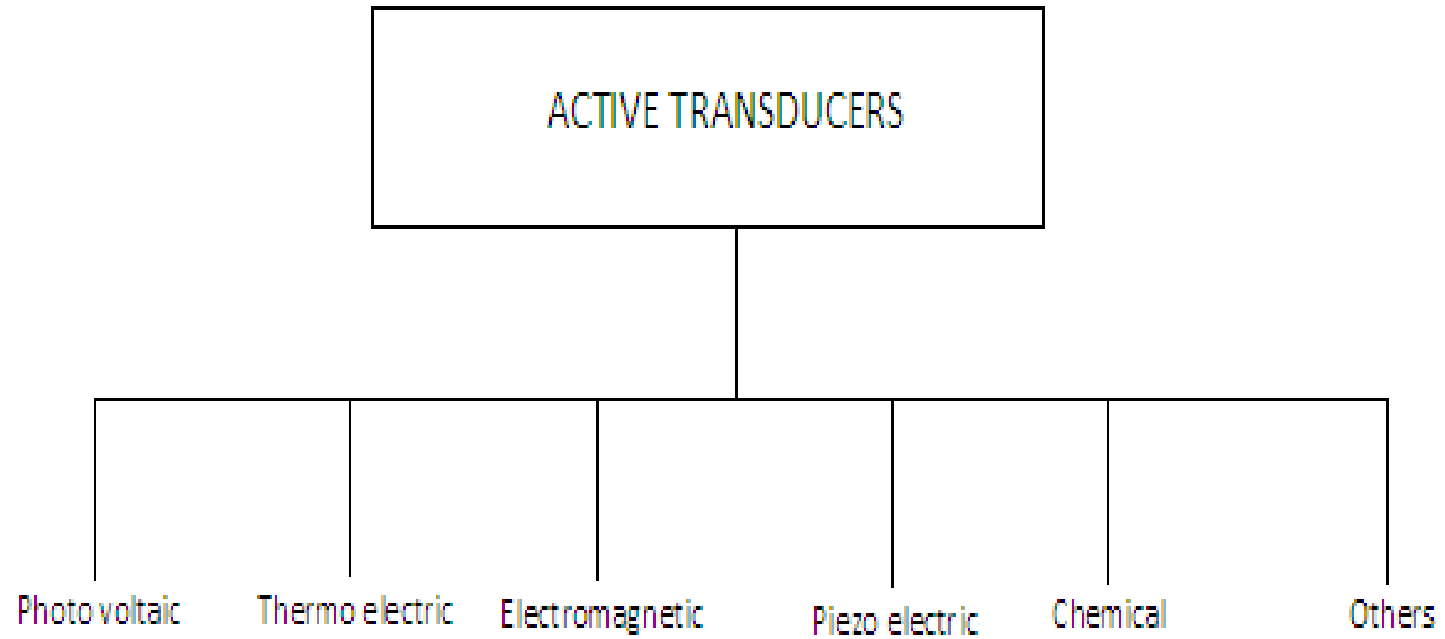

ACTIVE AND PASSIVE TRANSDUCERS

- **Passive Transducers :**

- I. These transducers need external source of power for their operation. So they are not self generating type transducers.
- II. A DC power supply or an audio frequency generator is used as an external power source.
- III. These transducers produce the output signal in the form of variation in resistance, capacitance, inductance or some other electrical parameter in response to the quantity to be measured.

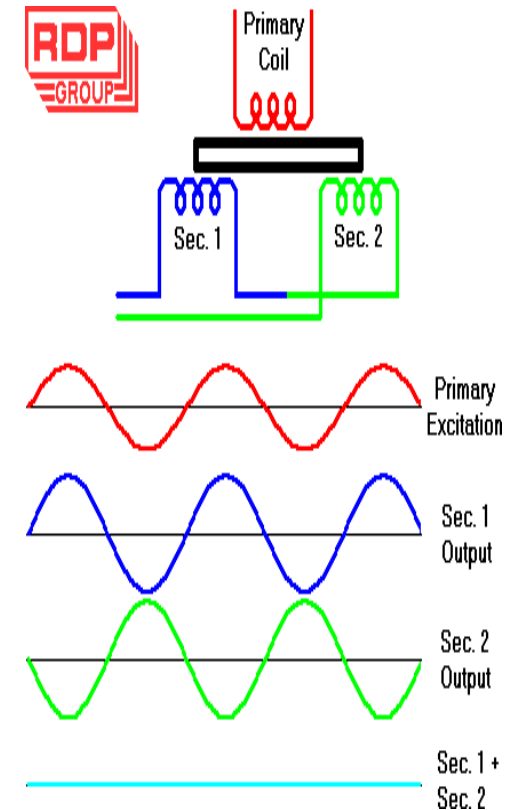

CLASSIFICATION OF PASSIVE TRANSDUCERS

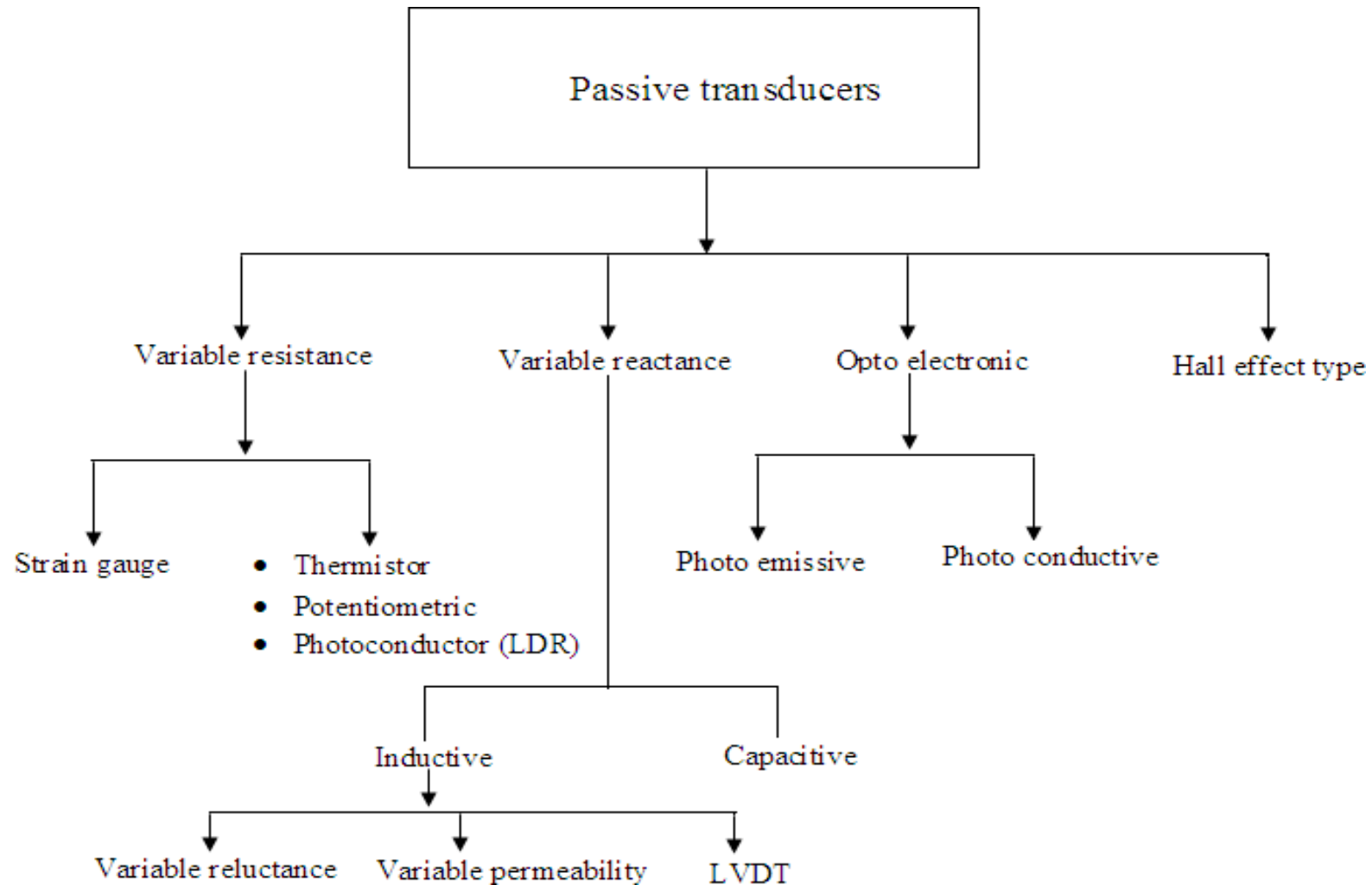

PRIMARY AND SECONDARY TRANSDUCERS

- Some transducers contain the mechanical as well as electrical device. The mechanical device converts the physical quantity to be measured into a mechanical signal. Such mechanical device are called as the primary transducers, because they deal with the physical quantity to be measured.
- The electrical device then convert this mechanical signal into a corresponding electrical signal. Such electrical device are known as secondary transducers.

CONTD

- Ref fig in which the diaphragm act as primary transducer. It convert pressure (the quantity to be measured) into displacement(the mechanical signal).
- The displacement is then converted into change in resistance using strain gauge. Hence strain gauge acts as the secondary transducer.

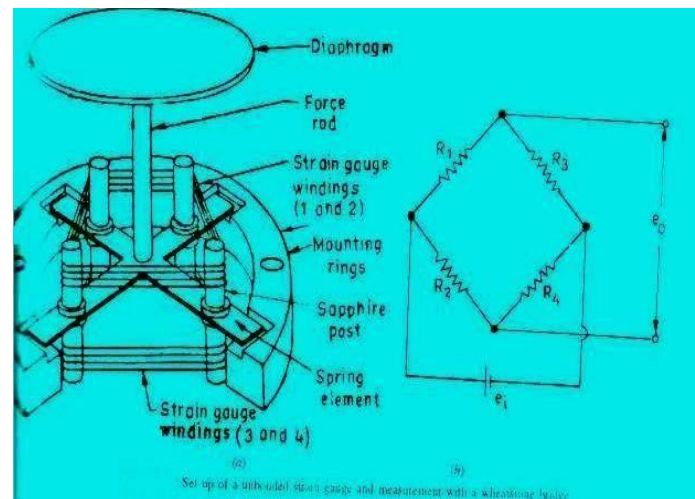

CLASSIFICATION OF TRANSDUCERS

According to Transduction Principle

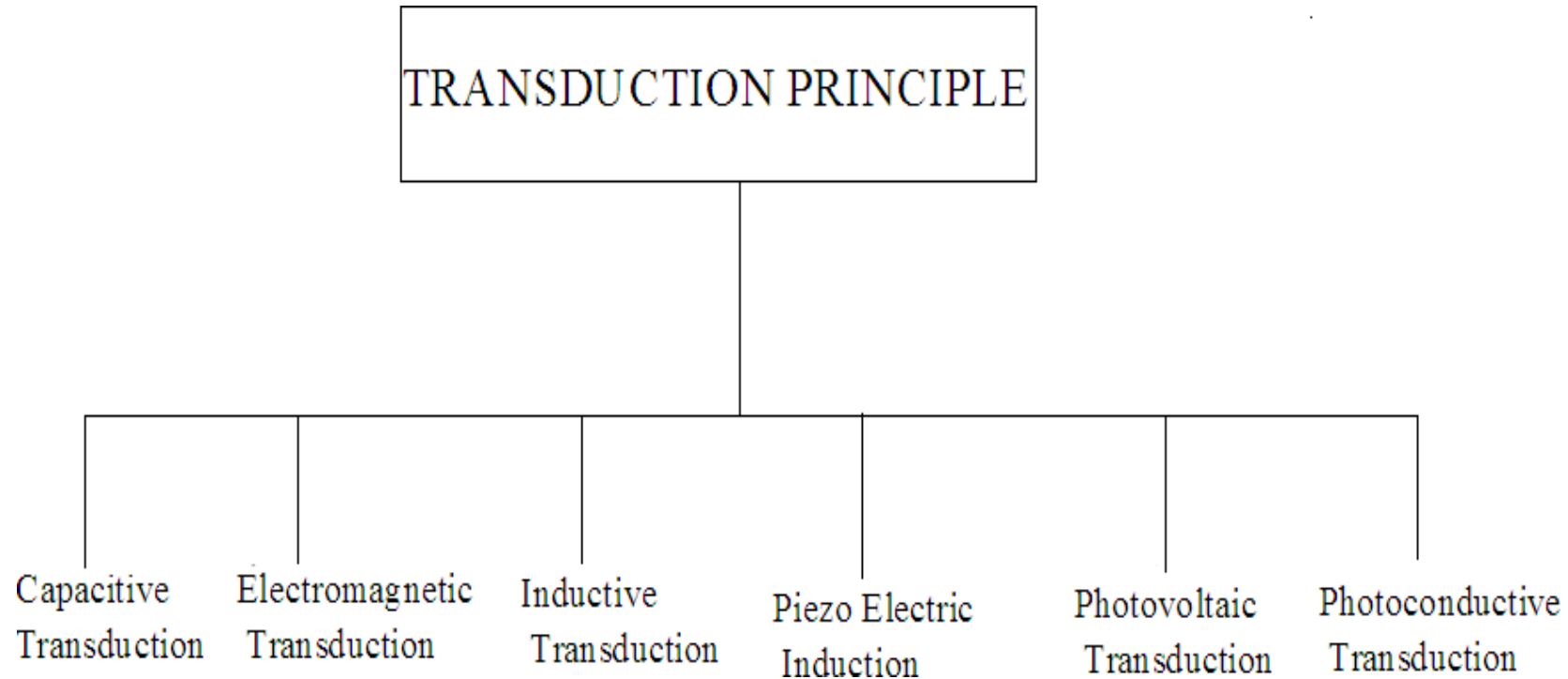

CLASSIFICATION OF TRANSDUCERS

According to Transduction Principle

CAPACITIVE TRANSDUCER:

- In capacitive transduction transducers the measurand is converted to a change in the capacitance.
- A typical capacitor is comprised of two parallel plates of conducting material separated by an electrical insulating material called a dielectric. The plates and the dielectric may be either flattened or rolled.
- The purpose of the dielectric is to help the two parallel plates maintain their stored electrical charges.
- The relationship between the capacitance and the size of capacitor plate, amount of plate separation, and the dielectric is given by

$$C = \epsilon_0 \epsilon_r A / d$$

d is the separation distance of plates (m)

C is the capacitance (F Farad)

ϵ_0 : absolute permittivity of vacuum

ϵ_r : relative permittivity

A is the effective (overlapping) area of capacitor plates (m²)

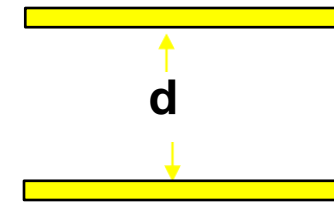

Area=A

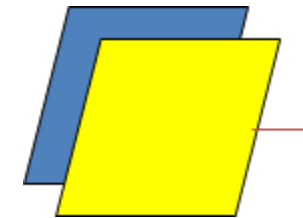

Either A, d or ϵ can be varied.



CLASSIFICATION OF TRANSDUCERS

According to Transduction Principle

ELECTROMAGNETIC TRANSDUCTION:

- In electromagnetic transduction, the measurand is converted to voltage induced in conductor by change in the magnetic flux, in absence of excitation.
- The electromagnetic transducer are self generating active transducers
- The motion between a piece of magnet and an electromagnet is responsible for the change in flux

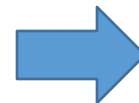
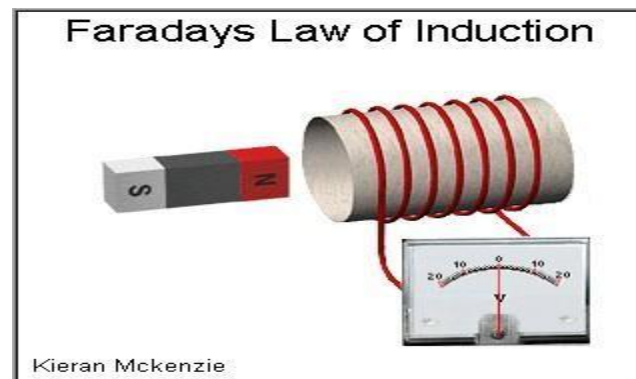

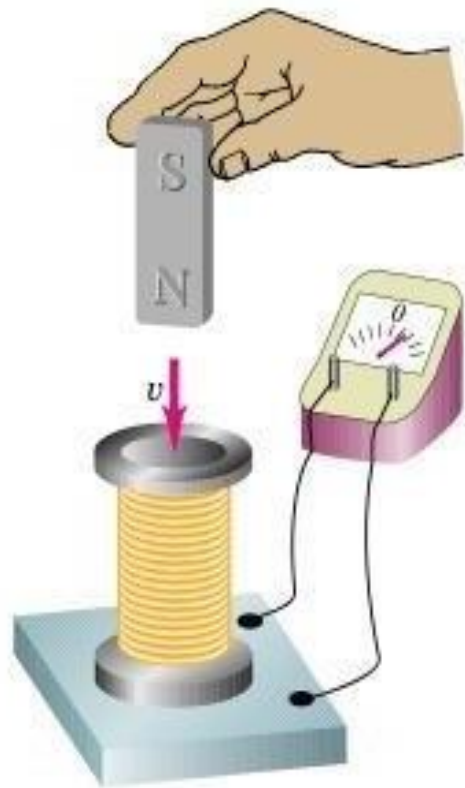

(a)

Copyright © Addison Wesley Longman, Inc.

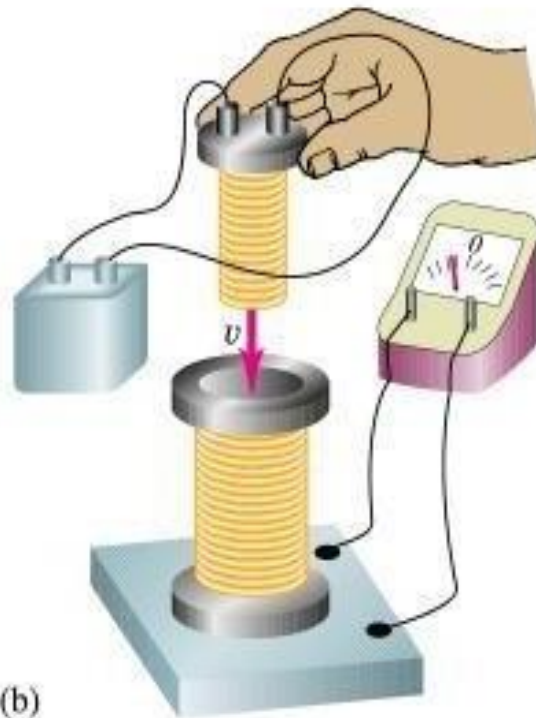

(b)



(c)

Current induced in a coil.

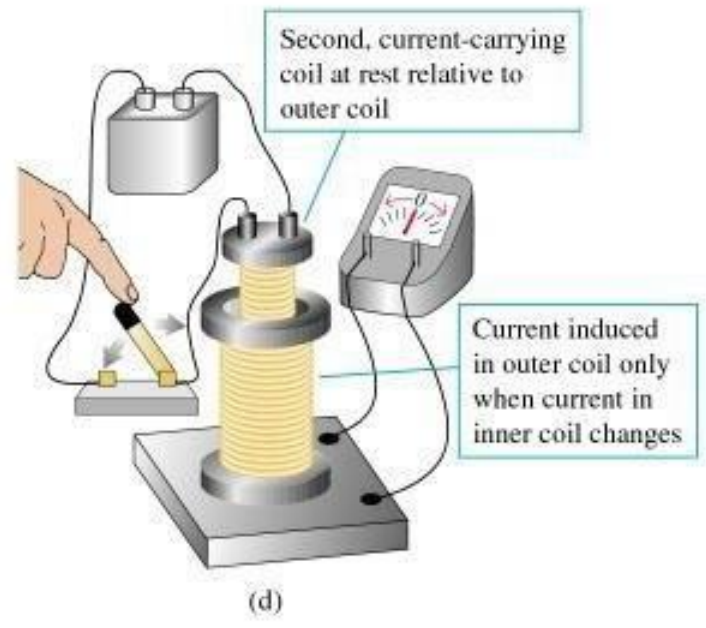
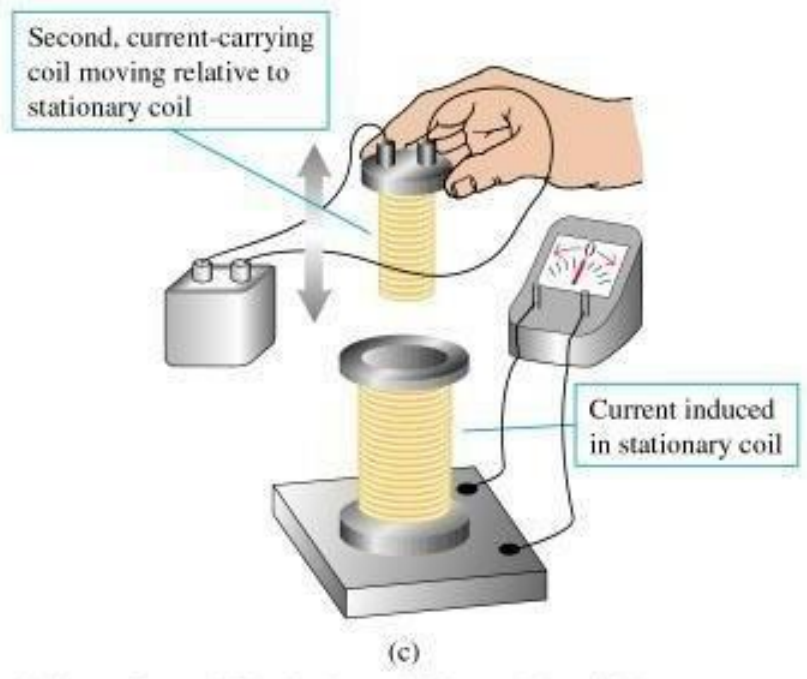
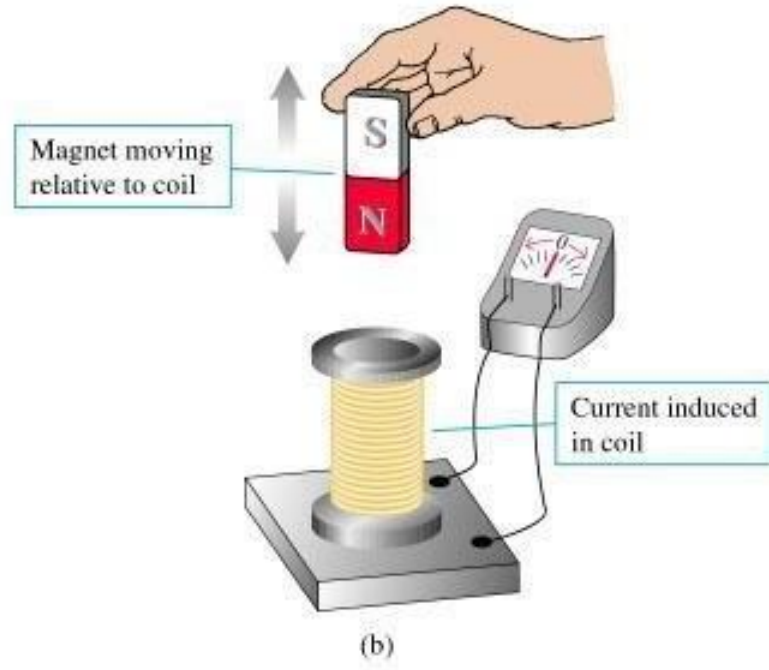
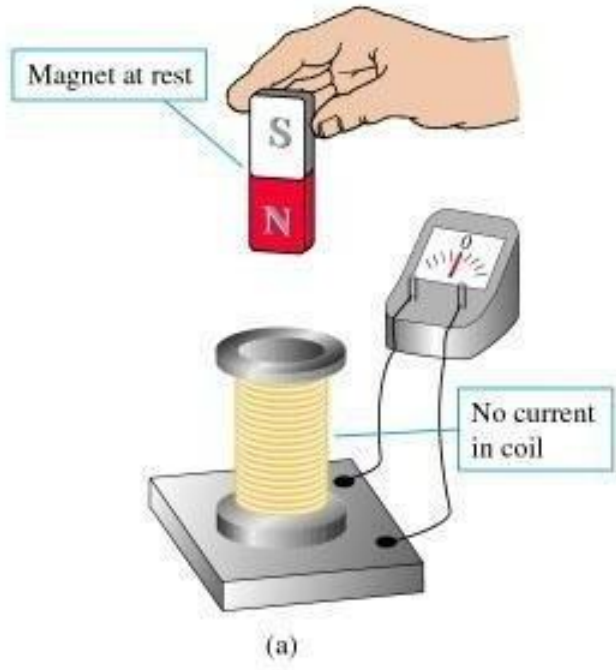

CLASSIFICATION OF TRANSDUCERS

According to Transduction Principle

INDUCTIVE TRANSDUCER:

- In inductive transduction, the measurand is converted into a change in the self inductance of a single coil. It is achieved by displacing the core of the coil that is attached to a mechanical sensing element

CLASSIFICATION OF TRANSDUCERS

According to Transduction Principle

PIEZO ELECTRIC INDUCTION :

•In piezoelectric induction the measurand is converted into a change in electrostatic charge q or voltage V generated by crystals when mechanically it is stressed as shown in fig.

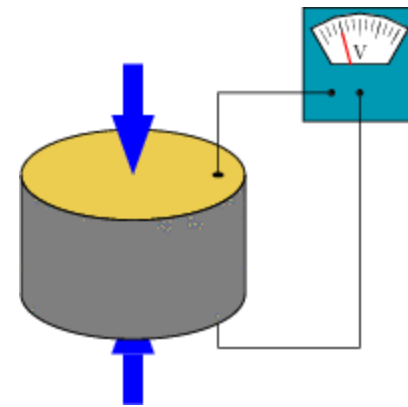

CLASSIFICATION OF TRANSDUCERS

According to Transduction Principle

PHOTOVOLTAIC TRANSDUCTION :

- In photovoltaic transduction the measurand is converted to voltage generated when the junction between dissimilar material is illuminated as shown in fig.

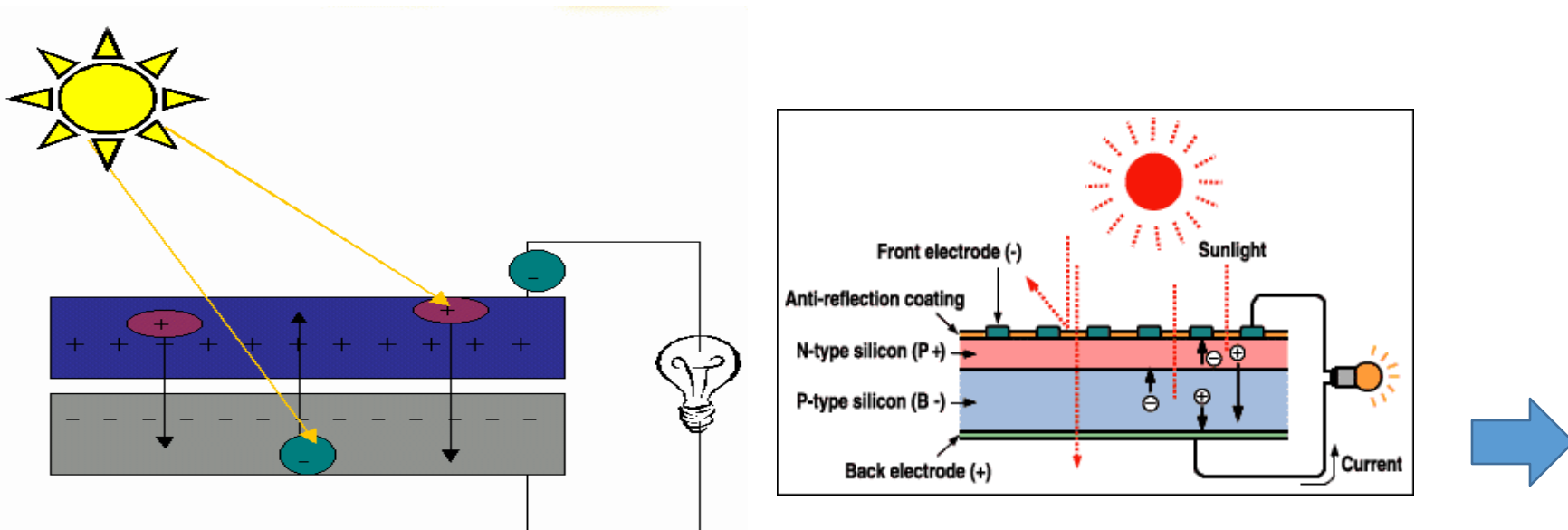

Physics of Photovoltaic Generation

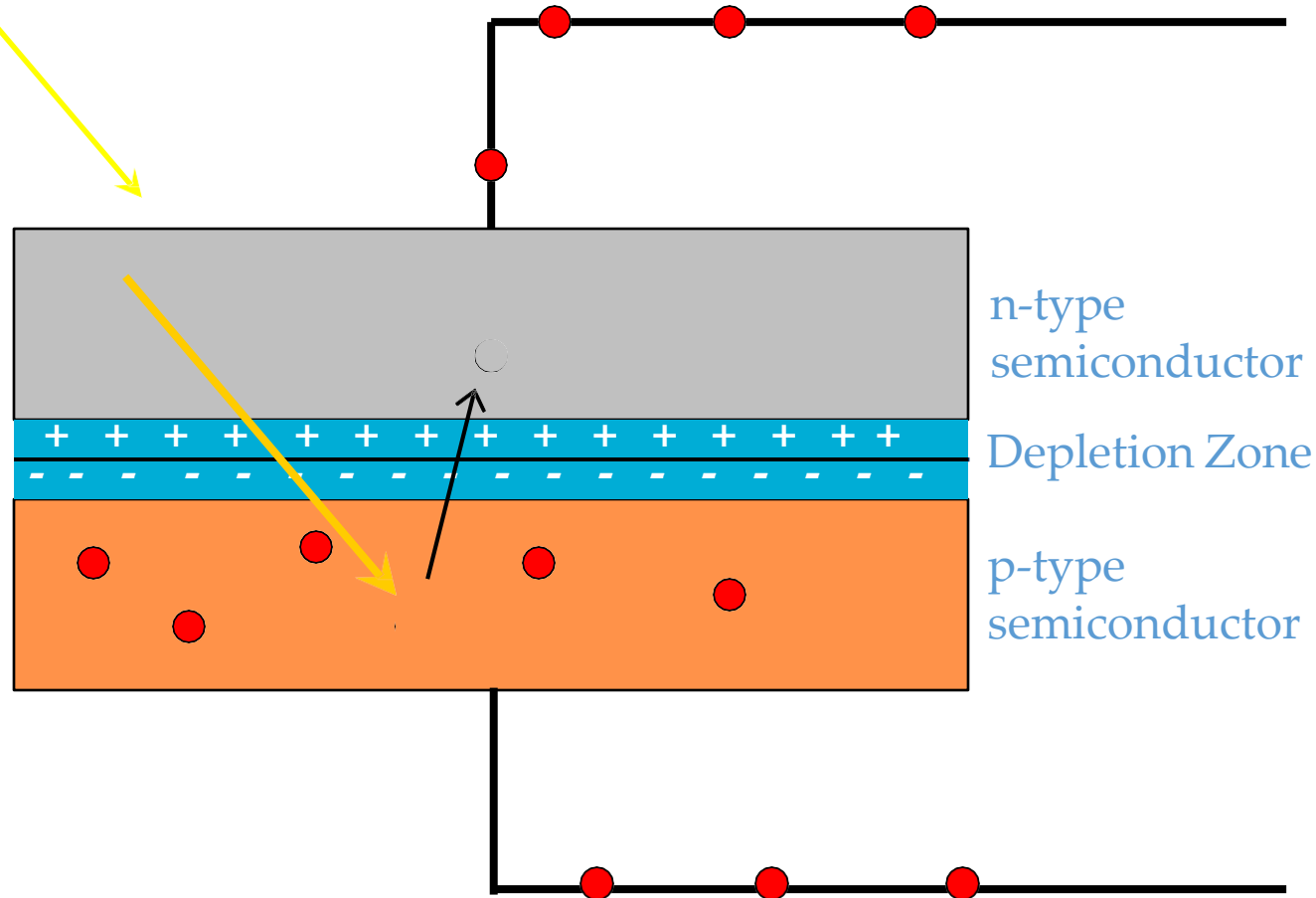
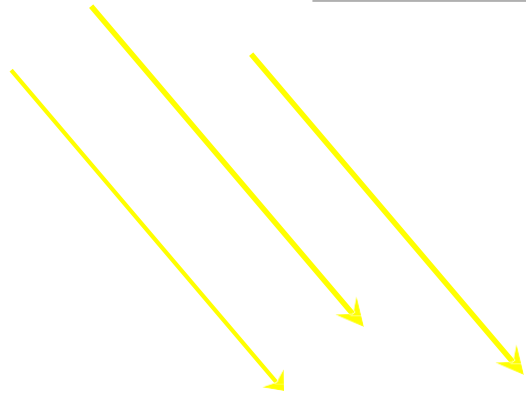
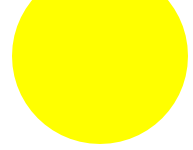

n-type
semiconductor

Depletion Zone

p-type
semiconductor

CLASSIFICATION OF TRANSDUCERS

According to Transduction Principle

PHOTO CONDUCTIVE TRANSDUCTION :

- In photoconductive transduction the measurand is converted to change in resistance of semiconductor material by the change in light incident on the material.

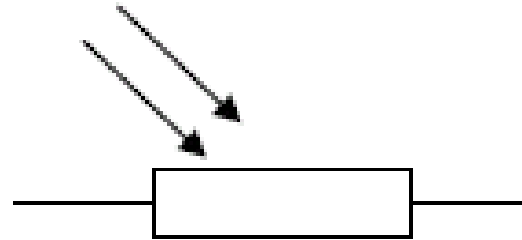

CLASSIFICATION OF TRANSDUCERS

Transducer and Inverse Transducer

TRANSDUCER:

- Transducers convert non electrical quantity to electrical quantity.

INVERSE TRANSDUCER:

- Inverse transducers convert electrical quantity to a non electrical quantity

PASSIVE TRANSDUCERS

- **Resistive transducers :**

- Resistive transducers are those transducers in which the resistance change due to the change in some physical phenomenon.

- The resistance of a metal conductor is expressed by a simple equation.

- $R = \rho L/A$

- Where R = resistance of conductor in Ω L = length of conductor in m

A = cross sectional area of conductor in m^2

ρ = resistivity of conductor material in Ω -m.

RESISTIVE TRANSDUCER

There are 4 type of resistive transducers.

1. Potentiometers (POT)
2. Strain gauge
3. Thermistors
4. Resistance thermometer

POTENTIOMETER

- The potentiometer are used for voltage division. They consist of a resistive element provided with a sliding contact. The sliding contact is called as wiper.
- The contact motion may be linear or rotational or combination of the two. The combinational potentiometer have their resistive element in helix form and are called helipots.
- Fig shows a linear pot and a rotary pot.

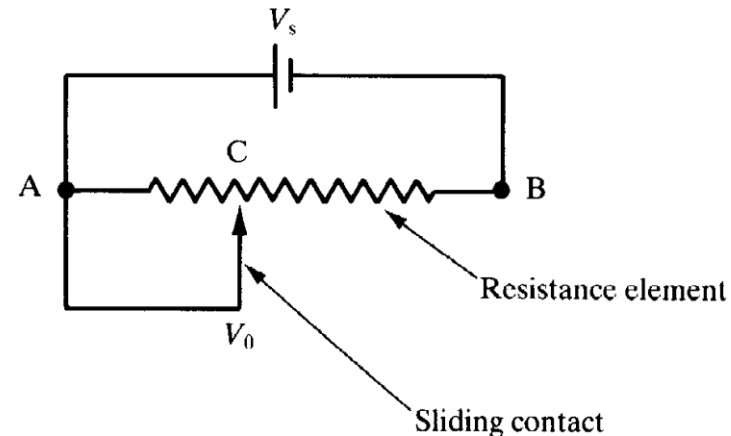
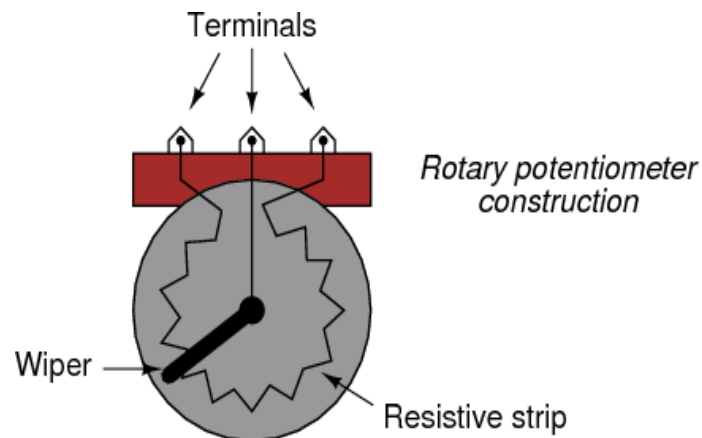

STRAIN GAUGE

- The strain gauge is a passive, resistive transducer which converts the mechanical elongation and compression into a resistance change.
- This change in resistance takes place due to variation in length and cross sectional area of the gauge wire, when an external force acts on it.

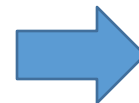
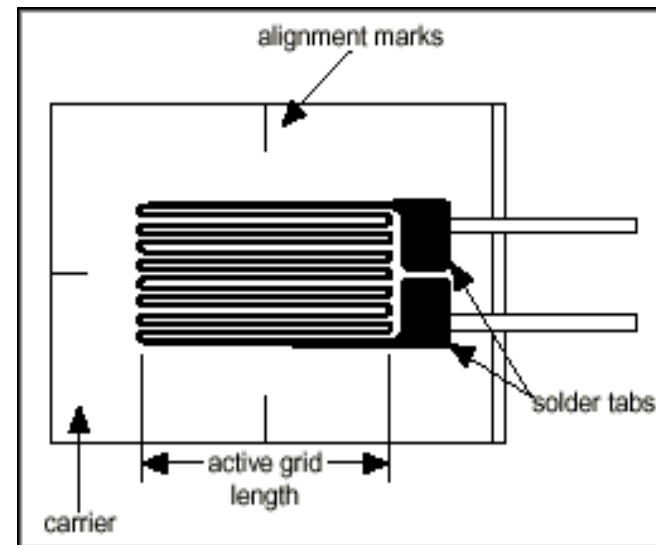
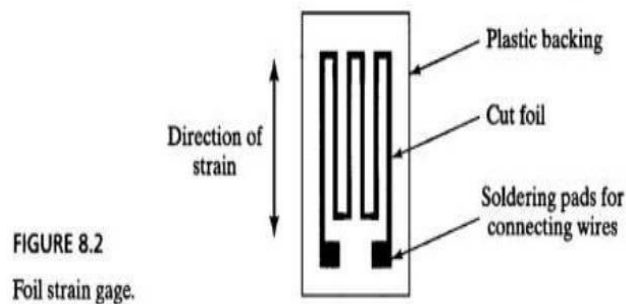

TYPES OF STRAIN GAUGE

- The type of strain gauge are as
 1. Wire gauge
 - a) Unbonded
 - b) Bonded
 - c) Foil type
 2. Semiconductor gauge

UNBONDED STRAIN GAUGE

- An unbonded meter strain gauge is shown in fig
- This gauge consist of a wire stretched between two point in an insulating medium such as air. The wires may be made of various copper, nickel, crome nickle or nickle iron alloys.
- In fig the element is connected via a rod to diaphragm which is used for sensing the pressure. The wire are tensioned to avoid buckling when they experience the compressive force.

- The unbounded meter wire gauges used almost exclusively in transducer application employ preloaded resistance wire connected in Wheatstone bridge as shown in fig.
- At initial preload the strain and resistance of the four arms are nominally equal with the result the output voltage of the bridge is equal to zero.
- Application of pressure produces a small displacement , the displacement increases a tension in two wire and decreases it in the other two thereby increase the resistance of two wire which are in tension and decreasing the resistance of the remaining two wire .
- This causes an unbalance of the bridge producing an output voltage which is proportional to the input displacement and hence to the applied pressure .

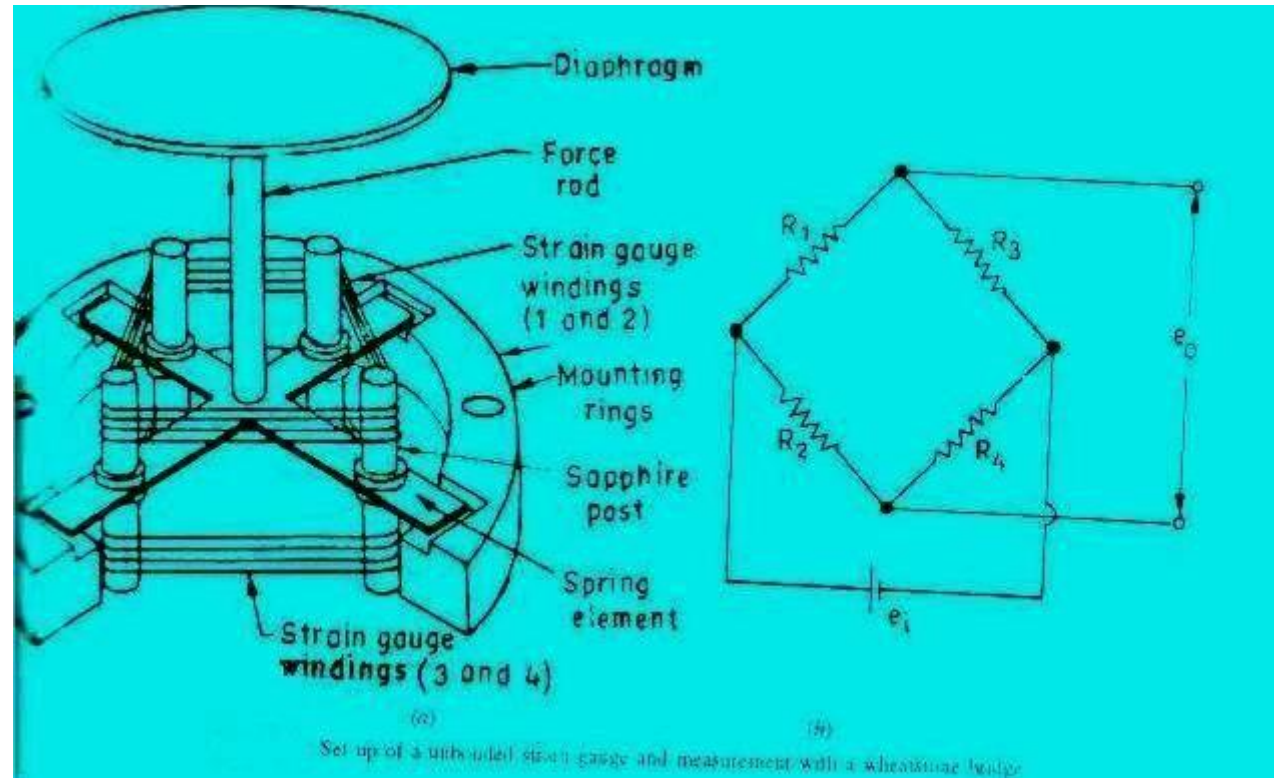

BONDED STRAIN GAUGE

- The bonded metal wire strain gauge are used for both stress analysis and for construction of transducer.
- A resistance wire strain gauge consist of a grid of fine resistance wire. The grid is cemented to carrier which may be a thin sheet of paper Bakelite or Teflon.
- The wire is covered on top with a thin sheet of material so as to prevent it from any mechanical damage.
- The carrier is bonded with an adhesive material to the specimen which permit a good transfer of strain from carrier to grid of wires.

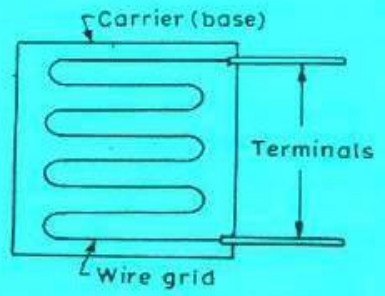

(a) Linear strain gauge.

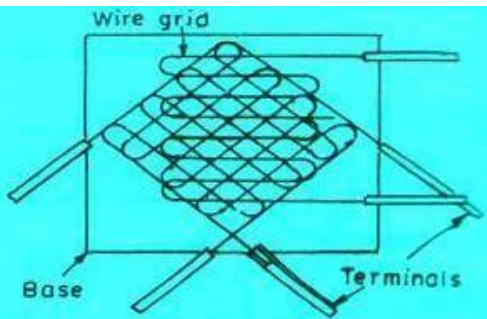

(b) Rosette.

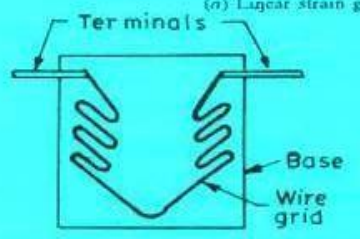

(c) Torque gauge.

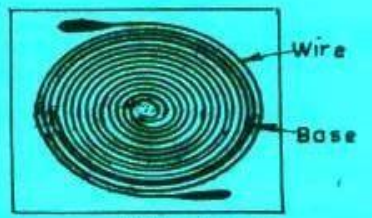

(d) Helical gauge.

Resistance wire strain gauge.

BONDED METAL FOIL STRAIN GAUGE

- It consist of following parts:

1. **Base (carrier) Materials:** several types of base material are used to support the wires. Impregnated paper is used for room temp. applications.
2. **Adhesive:** The adhesive acts as bonding materials. Like other bonding operation, successful strain gauge bonding depends upon careful surface preparation and use of the correct bonding agent.

In order that the strain be faithfully transferred on to the strain gauge, the bond has to be formed between the surface to be strained and the plastic backing material on which the gauge is mounted .

.

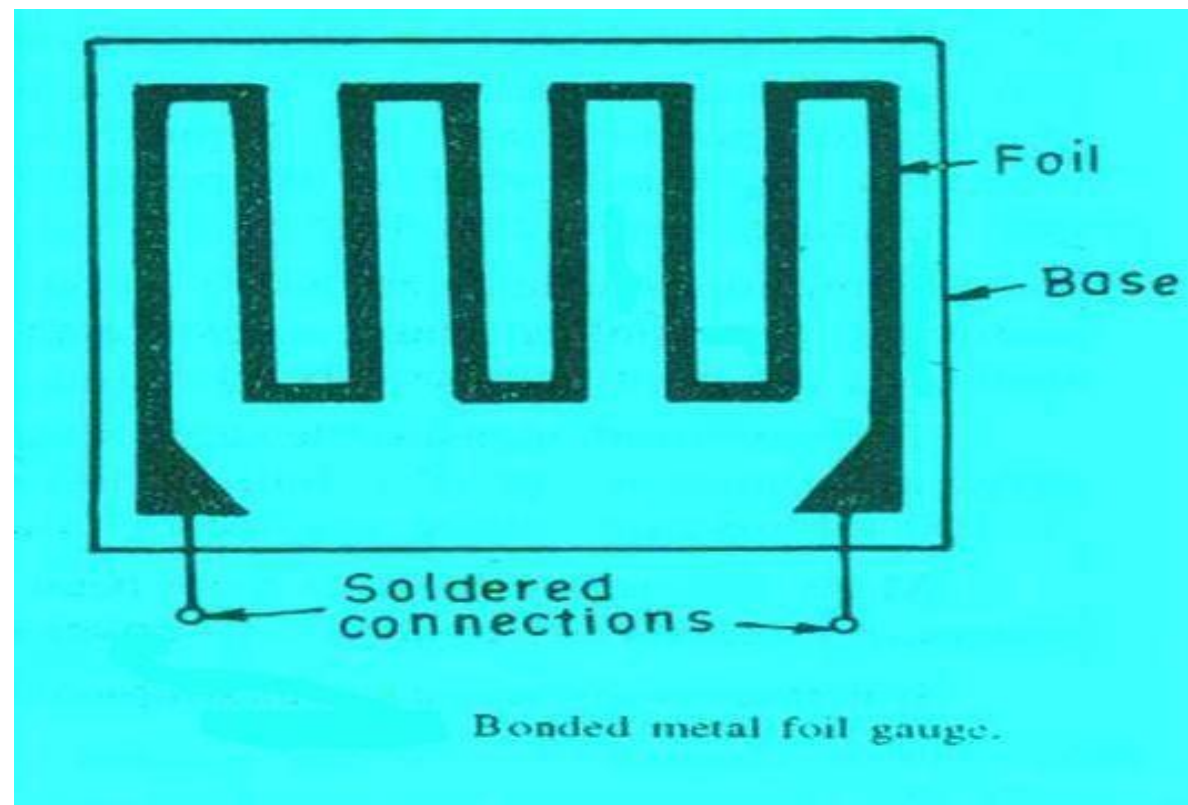

It is important that the adhesive should be suited to this backing and adhesive material should be quick drying type and also insensitive to moisture.

3. Leads: The leads should be of such materials which have low and stable resistivity and also a low resistance temperature coefficient.

Contd.

- This class of strain gauge is only an extension of the bonded metal wire strain gauges.
- The bonded metal wire strain gauge have been completely superseded by bonded metal foil strain gauges.
- Metal foil strain gauge use identical material to wire strain gauge and are used for most general purpose stress analysis application and for many transducers.

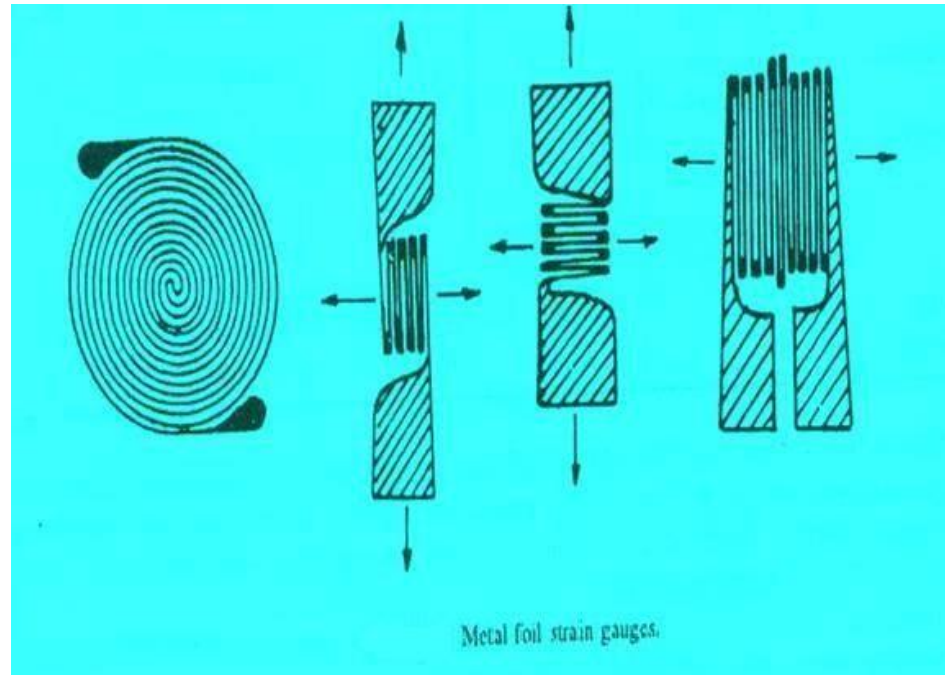

SEMICONDUCTOR GAUGE

- Semiconductor gauge are used in application where a high gauge factor is desired. A high gauge factor means relatively higher change in resistance that can be measured with good accuracy.
- The resistance of the semiconductor gauge change as strain is applied to it. The semiconductor gauge depends for their action upon the piezo-resistive effect i.e. change in value of resistance due to change in resistivity.
- Silicon and germanium are used as resistive material for semiconductor gauges.

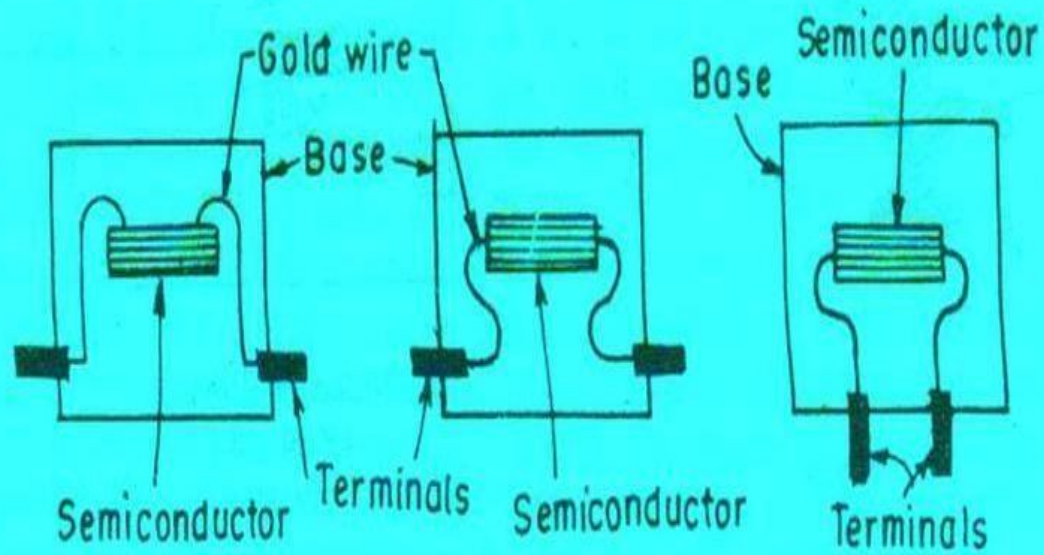

Semi-conductor strain gauge.

RESISTANCE THERMOMETER

- Resistance of metal increase with increases in temperature. Therefore metals are said to have a positive temperature coefficient of resistivity.
- Fig shows the simplest type of open wire construction of platinum resistance thermometer. The platinum wire is wound in the form of spirals on an insulating material such as mica or ceramic.
- This assembly is then placed at the tip of probe
- This wire is in direct contact with the gas or liquid whose temperature is to be measured.

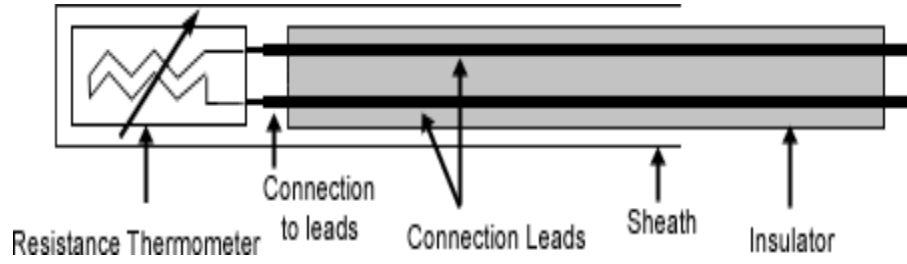
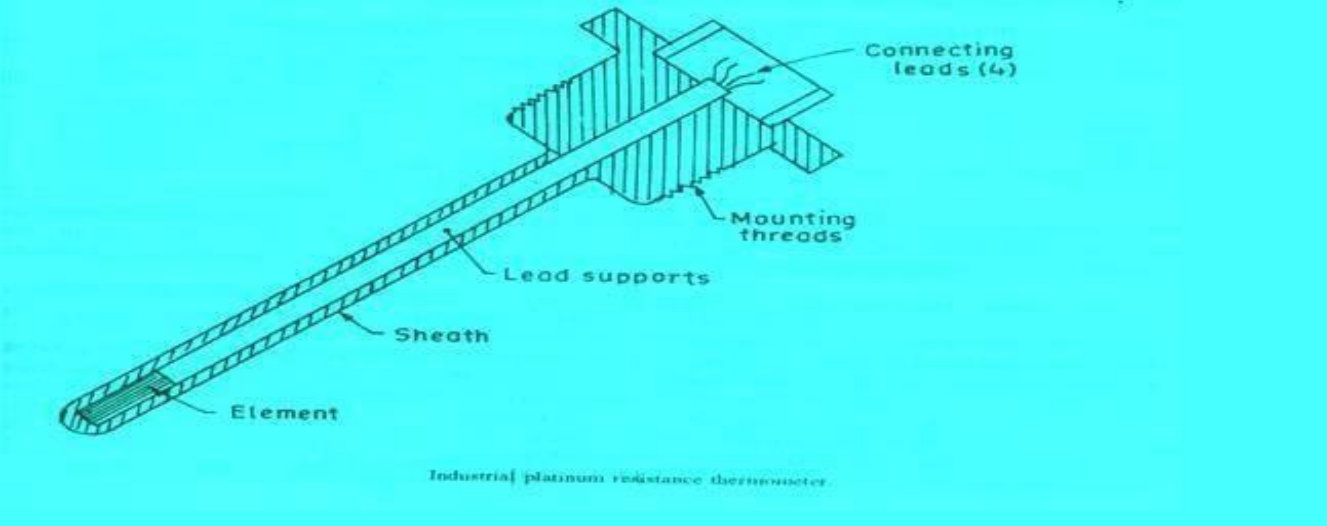

- The resistance of the platinum wire changes with the change in temperature of the gas or liquid
- This type of sensor have a positive temperature coefficient of resistivity as they are made from metals they are also known as resistance temperature detector
- Resistance thermometer are generally of probe type for immersion in medium whose temperature is to be measured or controlled.

THERMISTOR

- Thermistor is a contraction of a term —thermal resistor.
- Thermistors are temperature dependent resistors. They are made of semiconductor material which have negative temperature coefficient of resistivity i.e. their resistance decreases with increase of temperature.
- Thermistors are widely used in applications which involve measurement in the range of 0-60° Thermistors are composed of sintered mixture of metallic oxides such as manganese, Nickel, cobalt, copper, iron and uranium.



Temperature measurement using thermistor

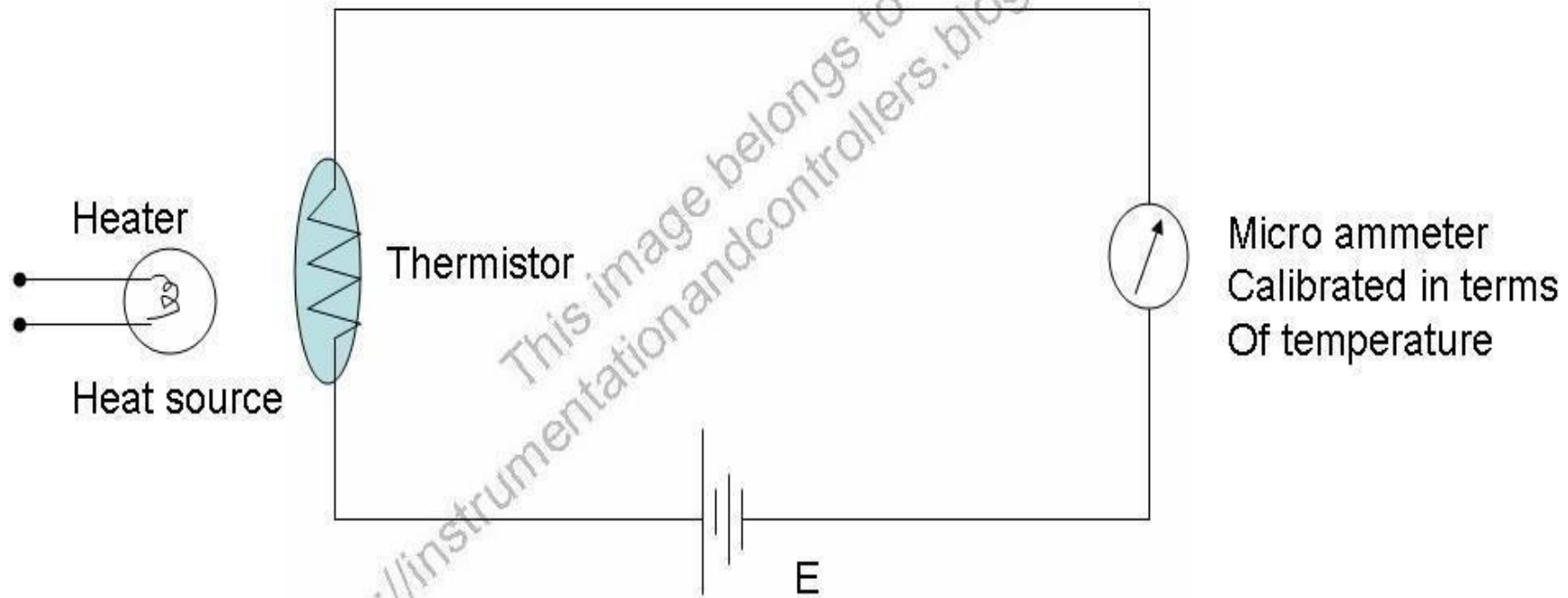

Contd.

- The thermistor may be in the form of beads, rods and discs.
- The thermistor provide a large change in resistance for small change in temperature. In some cases the resistance of thermistor at room temperature may decreases as much as 6% for each 1°C rise in temperature.

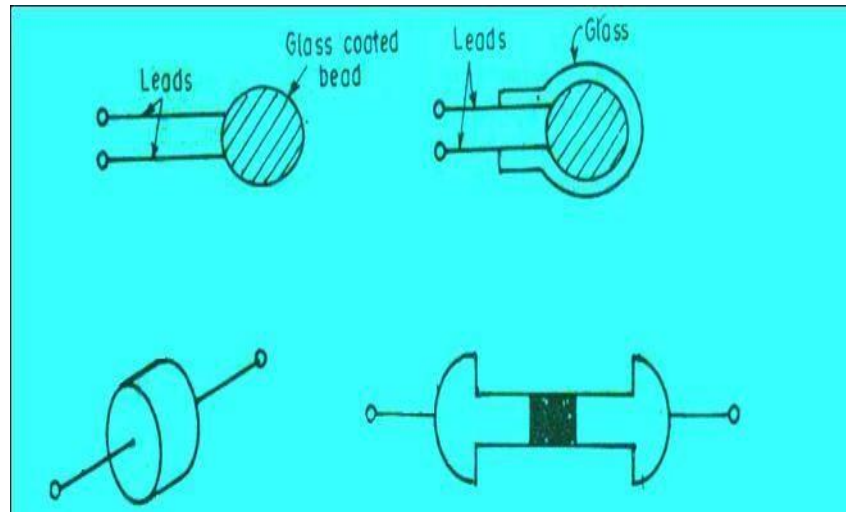

Thermocouples

Seebeck Effect

When a pair of dissimilar metals are joined at one end, and there is a temperature difference between the joined ends and the open ends, thermal emf is generated, which can be measured in the open ends.

This forms the basis of thermocouples.

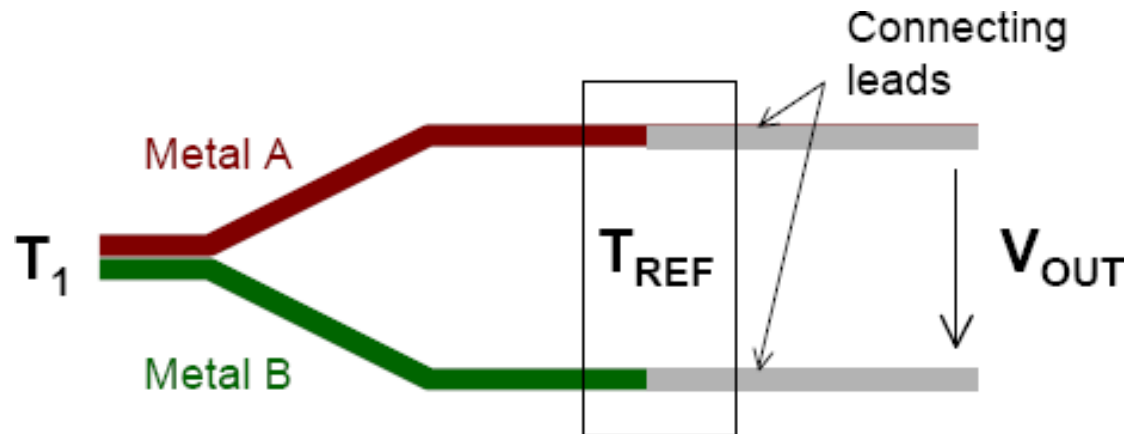

VARIABLE-INDUCTANCE TRANSDUCERS

- An inductive electromechanical transducer is a transducer which converts the physical motion into the change in inductance.
- Inductive transducers are mainly used for displacement measurement.



- The inductive transducers are of the self generating or the passive type. The self generating inductive transducers use the basic generator principle i.e. the motion between a conductor and magnetic field induces a voltage in the conductor.
- The variable inductance transducers work on the following principles.
 - Variation in self inductance
 - Variation in mutual inductance

PRINCIPLE OF VARIATION OF SELF INDUCTANCE

- Let us consider an inductive transducer having N turns and reluctance R. when current I is passed through the transducer, the flux produced is
- $\Phi = Ni / R$
- Differentiating w.r.t. to t,
- $d\Phi/dt = N/R * di/dt$
- The e.m.f. induced in a coil is given by
- $e = N * d\Phi/dt$

- $e = N * N/R * di/dt$
- $e = N^2 / R * di/dt$
- Self inductance is given by
- $L = e/di/dt = N^2 / R$
- The reluctance of the magnetic circuit is $R = l/\mu A$
- Therefore $L = N^2 / l/\mu A = N^2 \mu A / l$
- From eqn we can see that the self inductance may vary due to
 - i. Change in number of turns N
 - ii. Change in geometric configuration
 - iii. Change in permeability of magnetic circuit

CHANGE IN SELF INDUCTANCE WITH CHANGE IN NUMBER OF TURNS N

- From eqn we can see the output may vary with the variation in the number of turns. As inductive transducers are mainly used for displacement measurement, with change in number of turns the self inductance of the coil changes in-turn changing the displacement
- Fig shows transducers used for linear and angular displacement fig a shows an air cored transducer for the measurement of linear displacement and fig b shows an iron cored transducer used for angular displacement measurement.

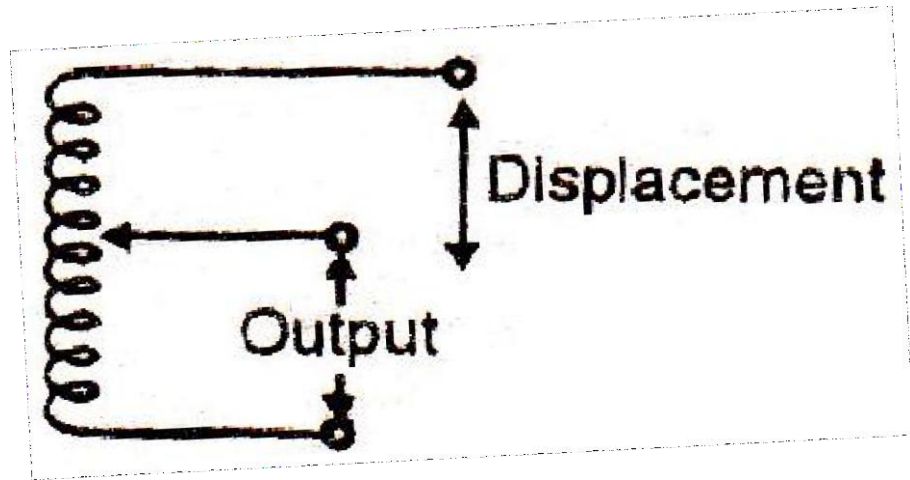

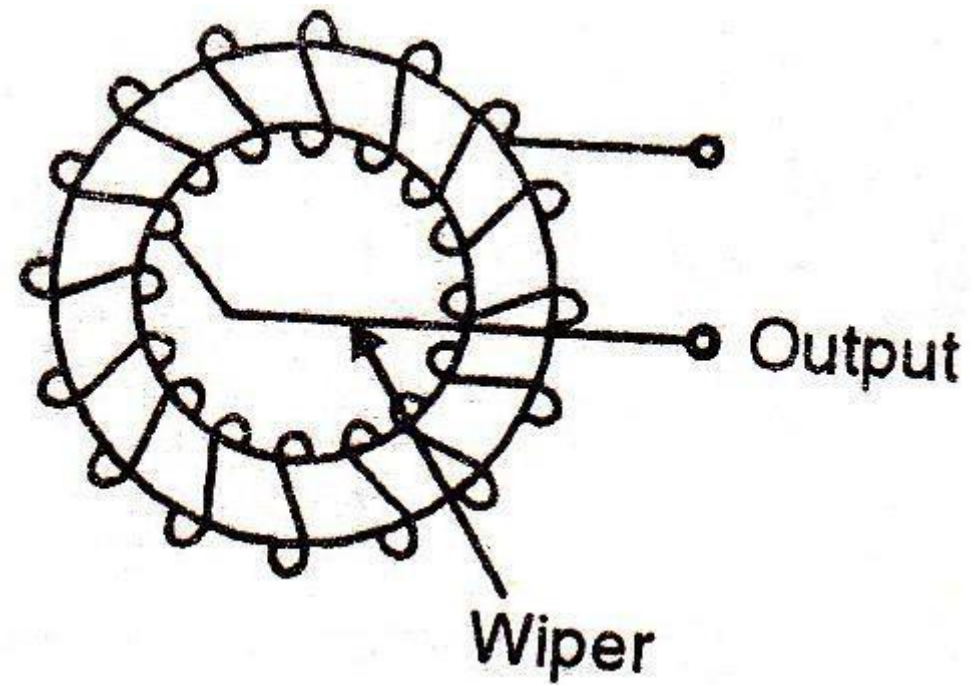

CHANGE IN SELF INDUCTANCE WITH CHANGE IN PERMEABILITY

- An inductive transducer that works on the principle of change in self inductance of coil due to change in the permeability is shown in fig
- As shown in fig the iron core is surrounded by a winding. If the iron core is inside the winding then the permeability increases otherwise permeability decreases. This cause the self inductance of the coil to increase or decrease depending on the permeability.
- The displacement can be measured using this transducer

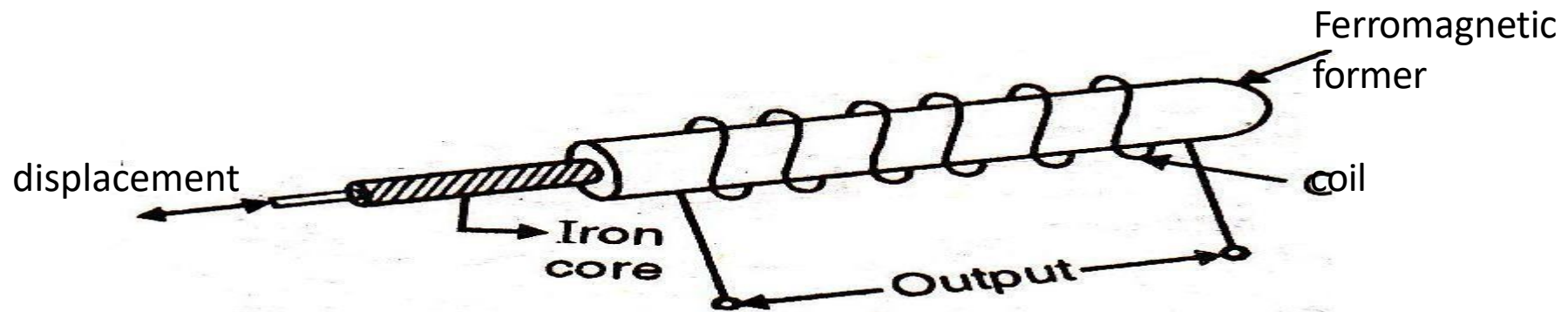

VARIABLE RELUCTANCE INDUCTIVE TRANSDUCER

- Fig shows a variable reluctance inductive transducer.
- As shown in fig the coil is wound on the ferromagnetic iron. The target and core are not in direct contact with each other. They are separated by an air gap.
- The displacement has to be measured is applied to the ferromagnetic core
- The reluctance of the magnetic path is found by the size of the air gap.
- The self inductance of coil is given by
- $L = N^2 / R = N^2 / R_i + R_a$
- N : number of turns
- R : reluctance of coil
- R_i : reluctance of iron path
- R_a : reluctance of air gap

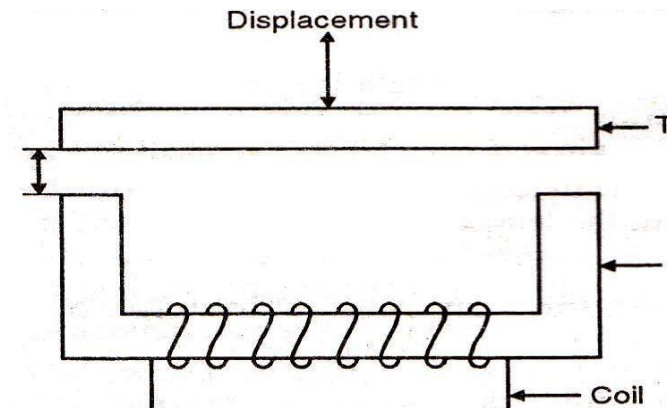

CONTD.

- The reluctance of iron path is negligible
- $L = N^2 / R_a$
- $R_a = l_a / \mu_0 A$
- Therefore $L \propto 1 / l_a$ i.e. self inductance of the coil is inversely proportional to the air gap l_a .
- When the target is near the core, the length is small. Hence the self inductance is large. But when the target is away from the core, the length is large. So reluctance is also large. This result in decrease in self inductance i.e. small self inductance.
- Thus inductance is function of the distance of the target from the core. Displacement changes with the length of the air gap, the self inductance is a function of the displacement.

PRINCIPLE OF CHANGE IN MUTUAL INDUCTANCE

- Multiple coils are required for inductive transducers that operate on the principle of change in mutual inductance.
- The mutual inductance between two coils is given by
 - $M = K\sqrt{L_1L_2}$
 - Where M : mutual inductance
 - K : coefficient of coupling
 - L1: self inductance of coil 1
 - L2 : self inductance of coil 2
- By varying the self inductance or the coefficient of coupling the mutual inductance can be varied

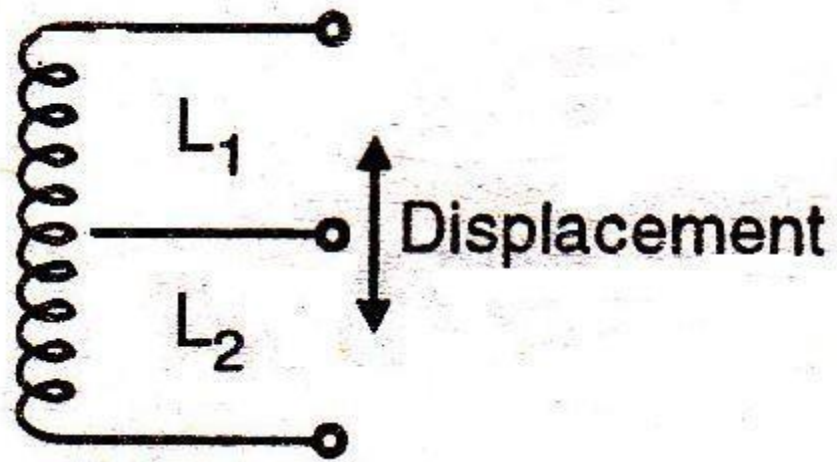

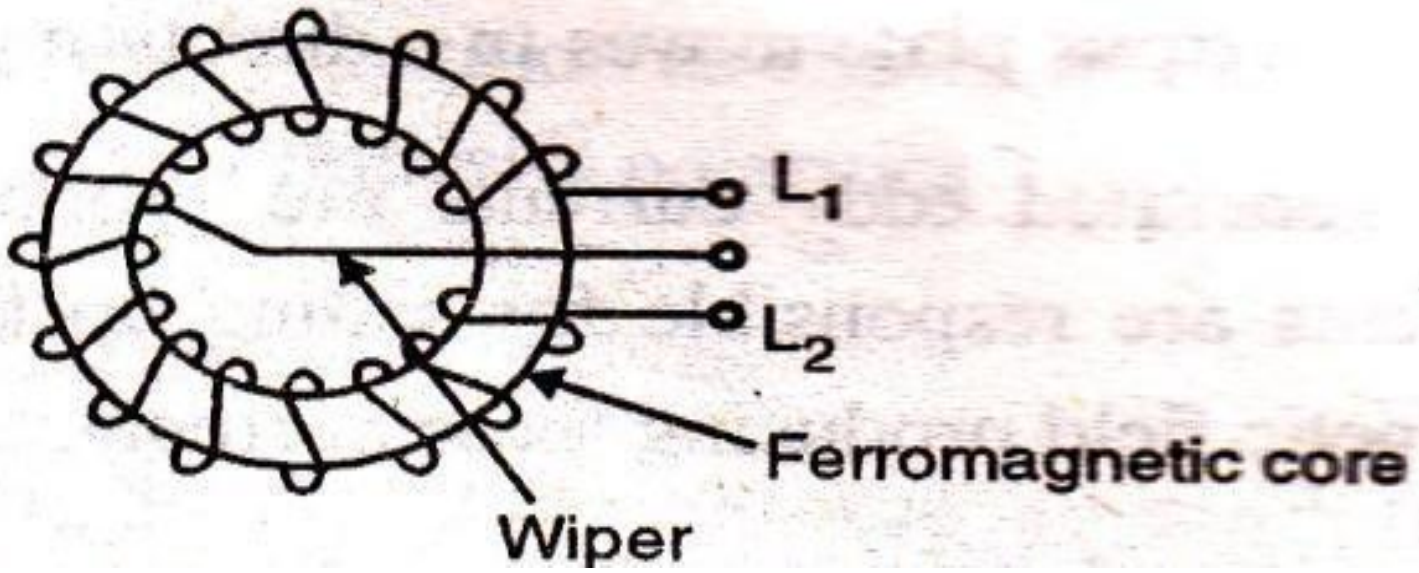

DIFFERENTIAL OUTPUT TRANSDUCERS

- Usually the change in self inductance ΔL for inductive transducers is insufficient for the detection of stages of an instrumentation system.
- The differential arrangement comprises of a coil that is divided in two parts as shown in fig a and b.
- In response to displacement, the inductance of one part increases from L to $L+\Delta L$ while the inductance of the other part decreases from L to $L-\Delta L$. The difference of two is measured so to get output $2\Delta L$. This will increase the sensitivity and minimize error.
- .

- Fig c shows an inductive transducer that provides differential output.

Due to variation in the reluctance, the self inductance of the coil changes. This is the principle of operation of differential output inductive transducer

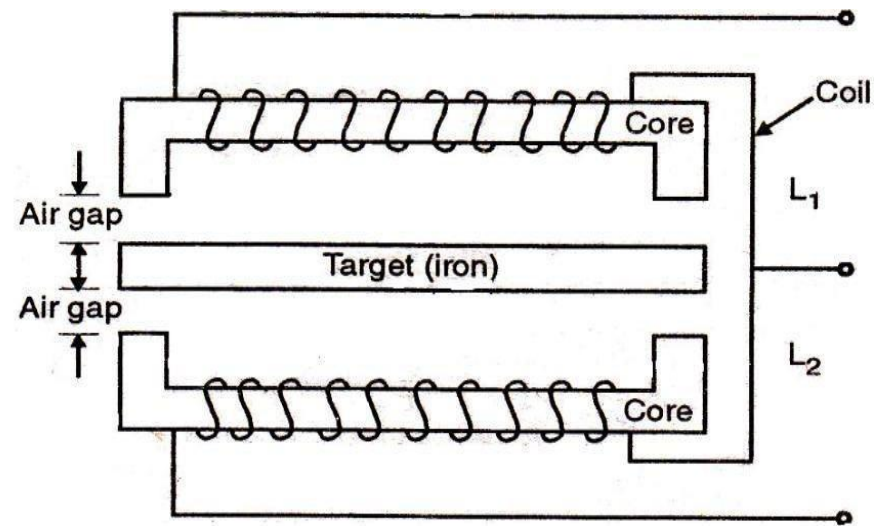

LINEAR VARIABLE DIFFERENTIAL TRANSFORMER(LVDT)

- AN LVDT transducer comprises a coil former on to which three coils are wound.
- The primary coil is excited with an AC current, the secondary coils are wound such that when a ferrite core is in the central linear position, an equal voltage is induced in to each coil.
- The secondary are connected in opposite so that in the central position the outputs of the secondary cancels each other out.

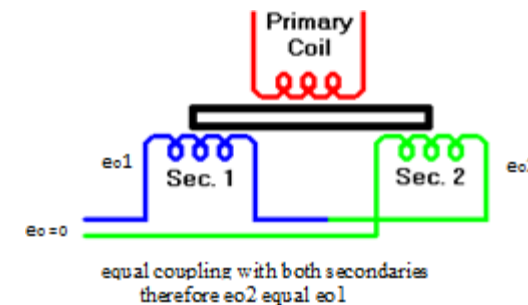
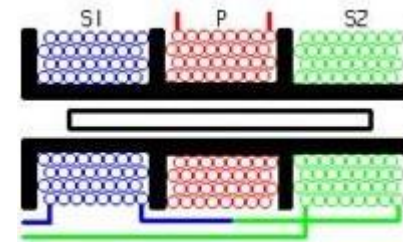

LVDT contd...

- The excitation is applied to the primary winding and the armature assists the induction of current in to secondary coils.
- When the core is exactly at the center of the coil then the flux linked to both the secondary winding will be equal. Due to equal flux linkage the secondary induced voltages (e_{o1} & e_{o2}) are equal but they have opposite polarities. Output voltage e_o is therefore zero. This position is called ~~—null position~~

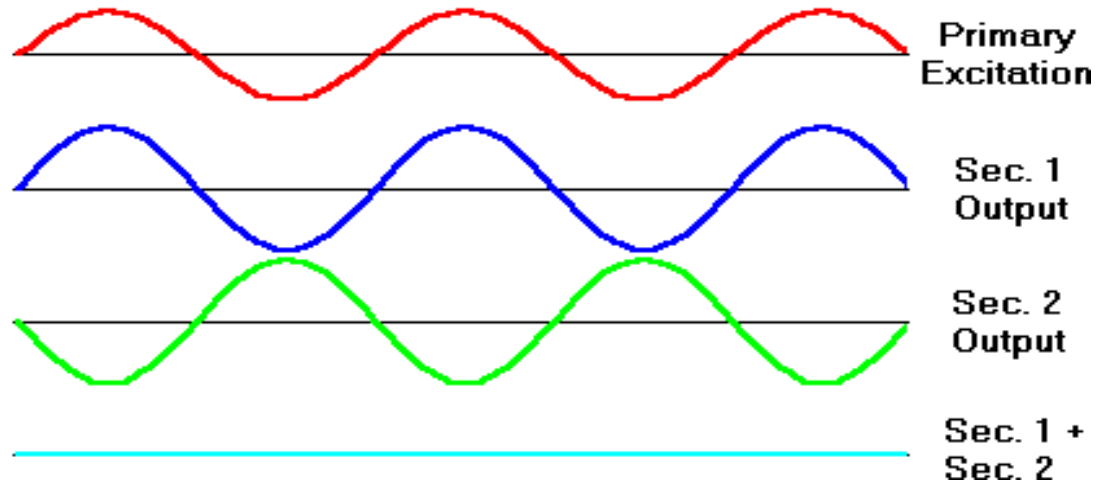
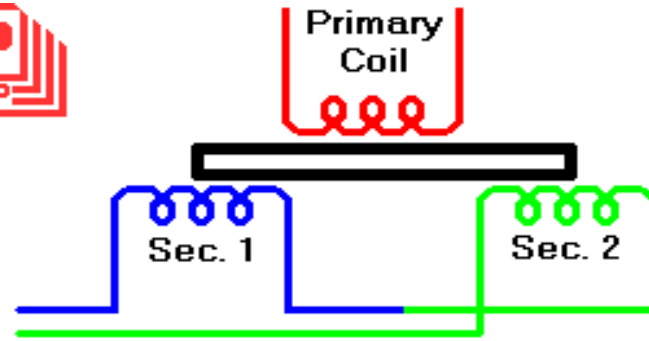

- Now if the core is displaced from its null position toward sec1 then flux linked to sec1 increases and flux linked to sec2 decreases. Therefore $e_{o1} > e_{o2}$ and the output voltage of LVDT e_o will be positive
- Similarly if the core is displaced toward sec2 then the $e_{o2} > e_{o1}$ and the output voltage of LVDT e_o will be negative.

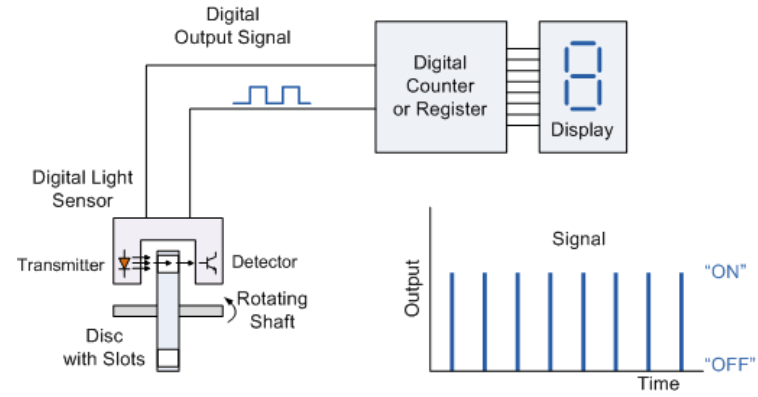

Transducers

Terminology

- Transducer that convert one form of energy into another
- **Sensors/Actuators** are input/output transducers
- Sensors can be *passive* (e.g. change in resistance) or *active* (output is a voltage or current level)
- Sensors can be *analog* (e.g. thermocouples) or *digital* (e.g. digital tachometer)

Transducer Types

Quantity being Measured	e Input Device (Sensor)	Output Device (Actuator)
Light Level	Light Dependant Resistor (LDR), Photodiode, Phototransistor, Solar Cell	Lights & Lamps, LED's & Displays, Fiber Optics
Temperature	Thermocouple, Thermistor, Thermostat, Resistive temperature detectors (RTD)	Heater, Fan, Peltier Elements
Force/Pressure	Strain Gauge, Pressure Switch, Load Cells	Lifts & Jacks, Electromagnetic, Vibration
Position	Potentiometer, Encoders, Reflective/Slotted Opto-switch, LVDT	Motor, Solenoid, Panel Meters
Speed	Tacho-generator, Reflective/Slotted Opto-coupler, Doppler Effect Sensors	AC and DC Motors, Stepper Motor, Brake
Sound	Carbon Microphone, Piezo-electric Crystal	Bell, Buzzer, Loudspeaker

Positional Sensors: potentiomet

Can be Linear or Rotational

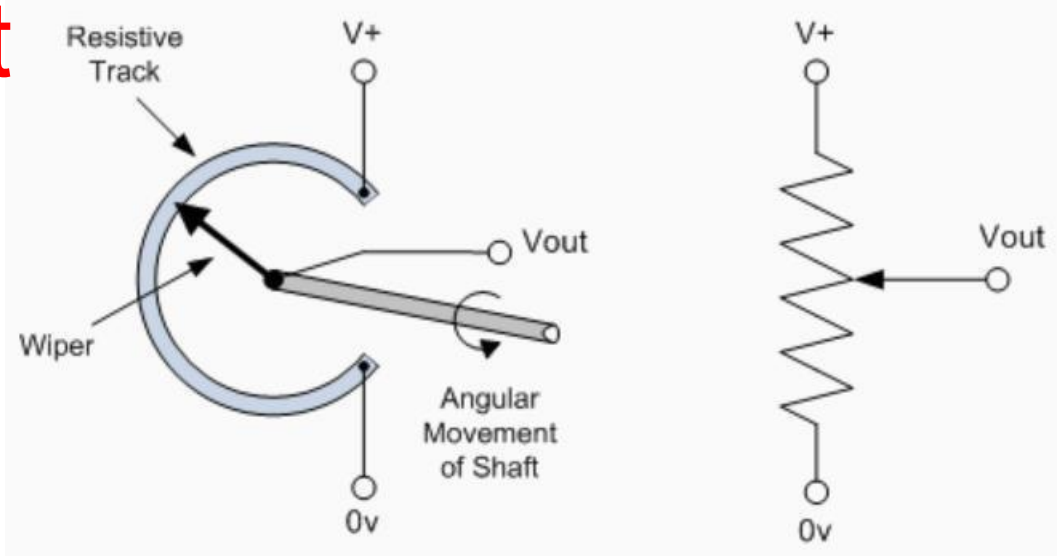

Processing circuit

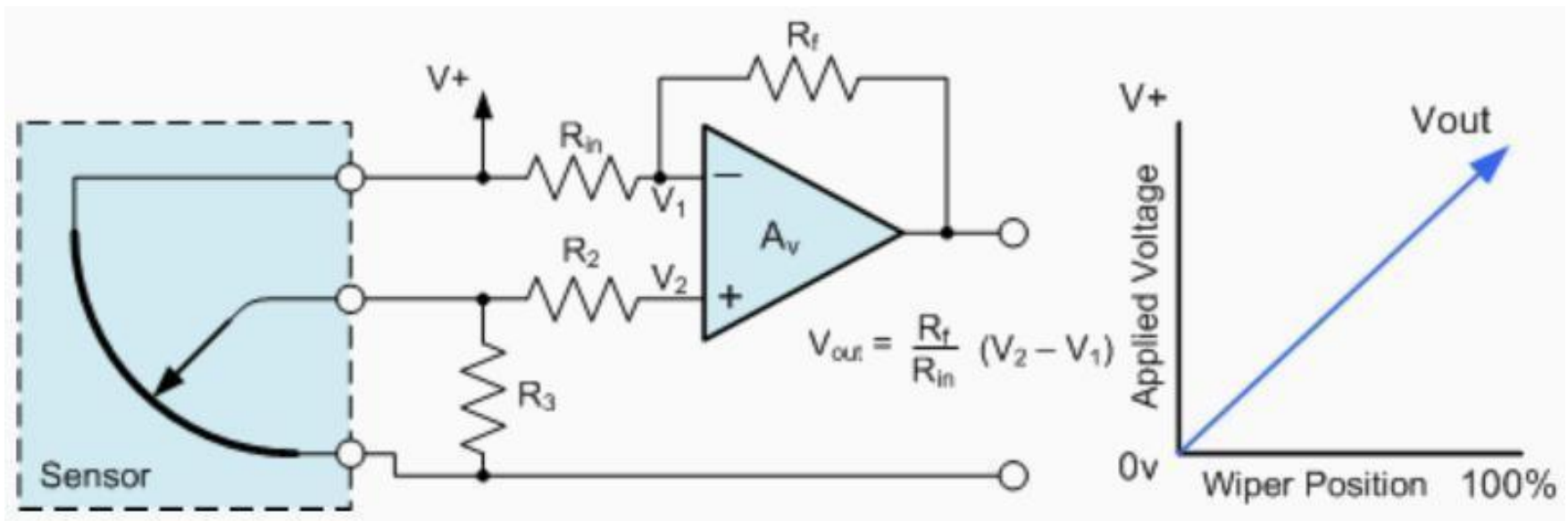

Positional Sensors: LVDT

Linear Variable
Differential
Transformer

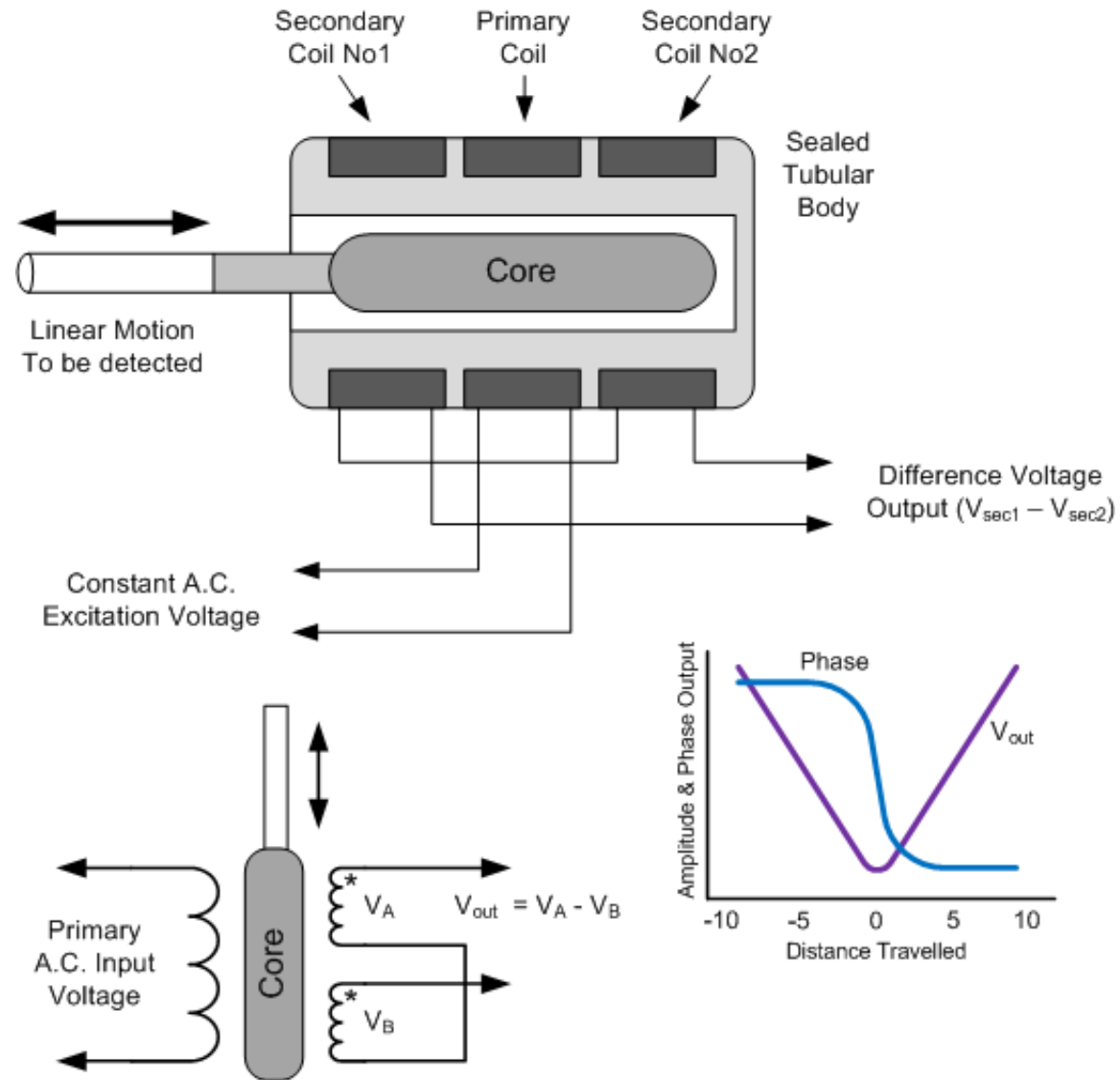

Positional Sensors: Inductive Proximity

Switch

- Detects the presence of metallic objects (non-contact) via changing inductance
- Sensor has 4 main parts: field producing **Oscillator** via a **Coil**; **Detection Circuit** which detects change in the field; and **Output Circuit** generating a signal (NO or NC)

Metallic object
being detected

Used in traffic lights (inductive loop buried under the road). Sense
objects in dirty environment.

Does not work for non-metallic objects. Omni-directional.

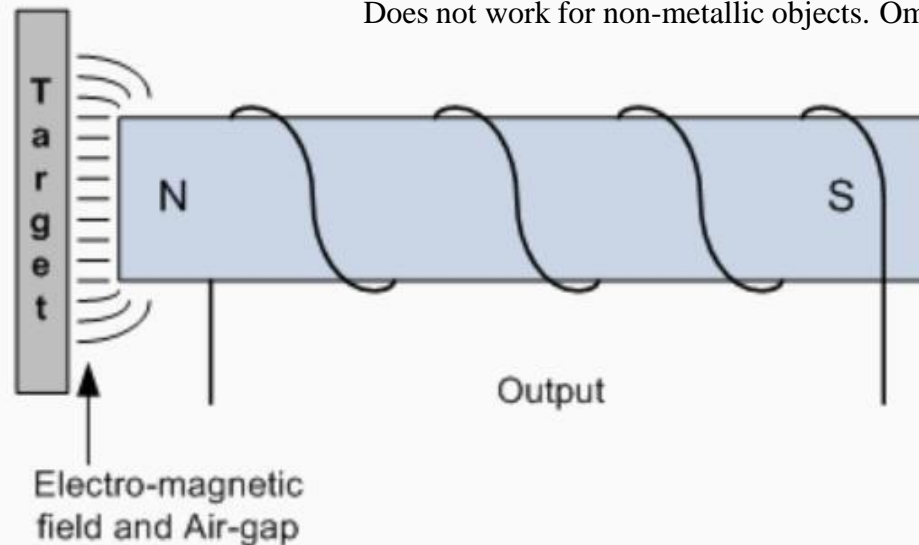

Positional Sensors: Rotary Encoders

• Incremental and absolute types

- Incremental encoder needs a counter, loses absolute position between power glitches, must be re-homed
- Absolute encoders common in CD/DVD drives

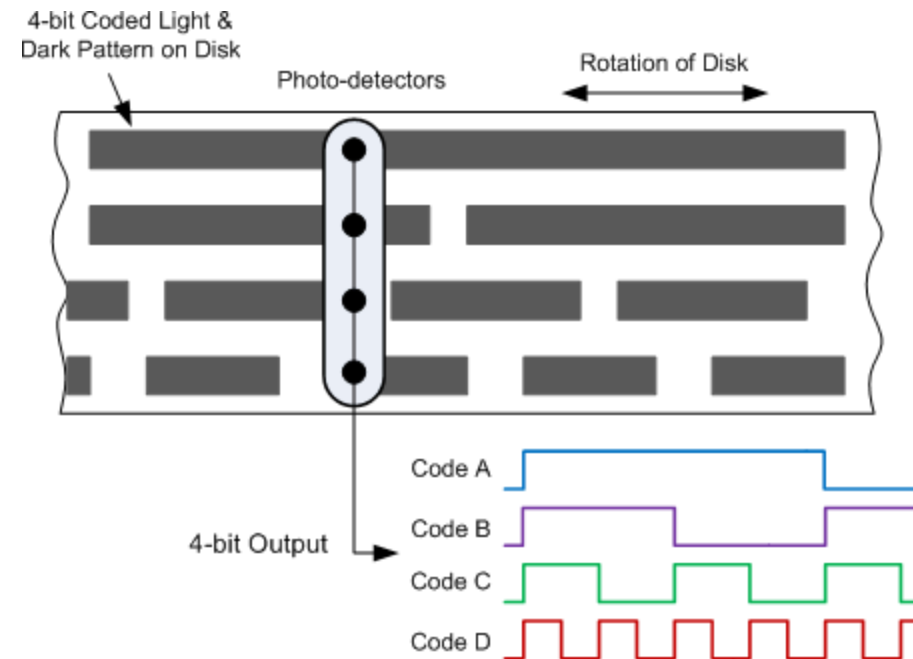
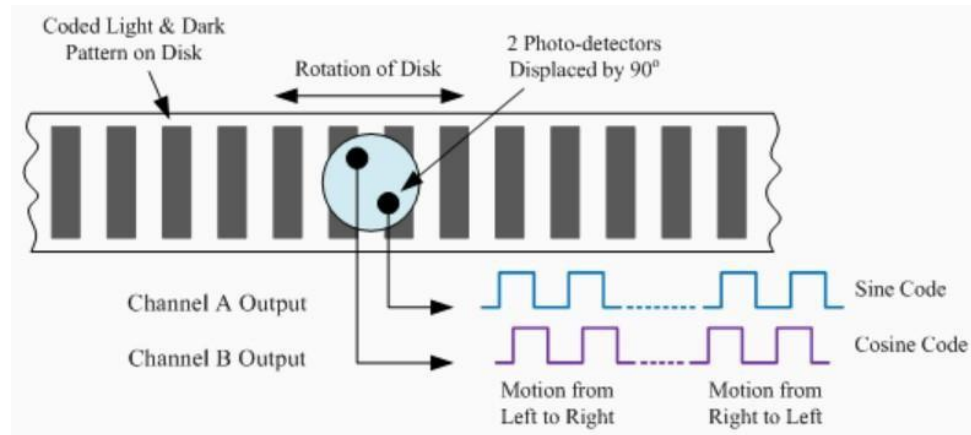

Temperature

- **Bimetallic switch** (electro-mechanical) – used in thermostats. Can be —creep|| or —snap|| action.

Creep-action: coil or spiral that unwinds or coils with changing temperature

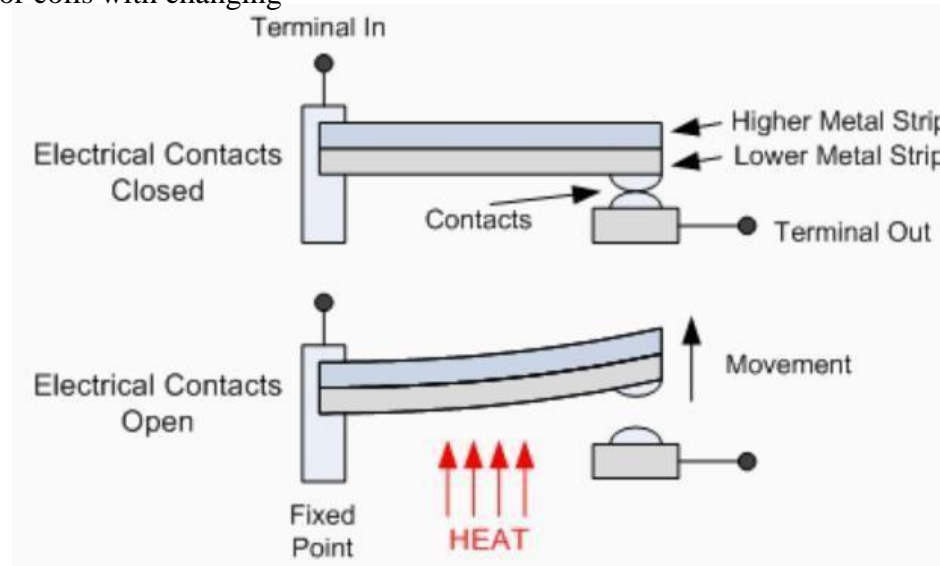

- **Thermistors** (thermally sensitive resistors); **Platinum Resistance Thermometer** (PRT), very high accuracy.

Thermocoupl

- **ES** Two dissimilar metals induce voltage difference (few mV per 10K) – electro-thermal or Seebeck effect

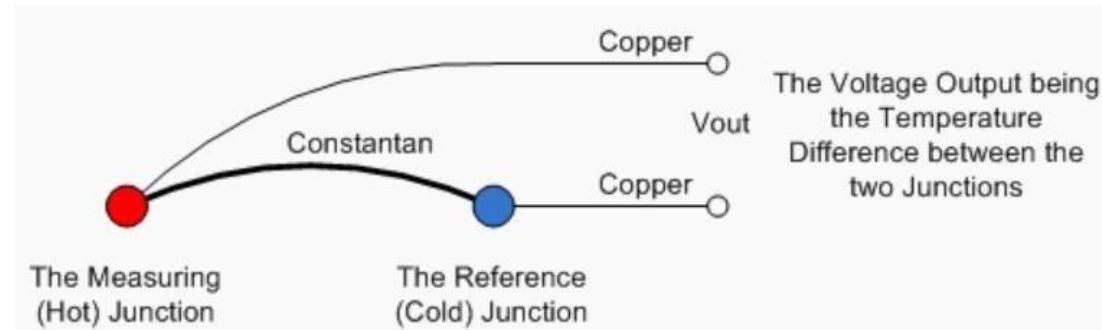

- Use op-amp to process/amplify the voltage
- Absolute accuracy of 1K is difficult

Thermocouple Sensor Colour Codes

Extension and Compensating Leads

Code Type	Conductors (+/-)	Sensitivity	British BS 1843:1952
E	Nickel Chromium / Constantan	-200 to 900°C	
J	Iron / Constantan	0 to 750°C	
K	Nickel Chromium / Nickel Aluminium	-200 to 1250°C	
N	Nicrosil / Nisil	0 to 1250°C	
T	Copper / Constantan	-200 to 350°C	
U	Copper / Copper Nickel Compensating for "S" and "R"	0 to 1450°C	

Light sensors: photoconductive cells

- Light dependent resistor (LDR) cell

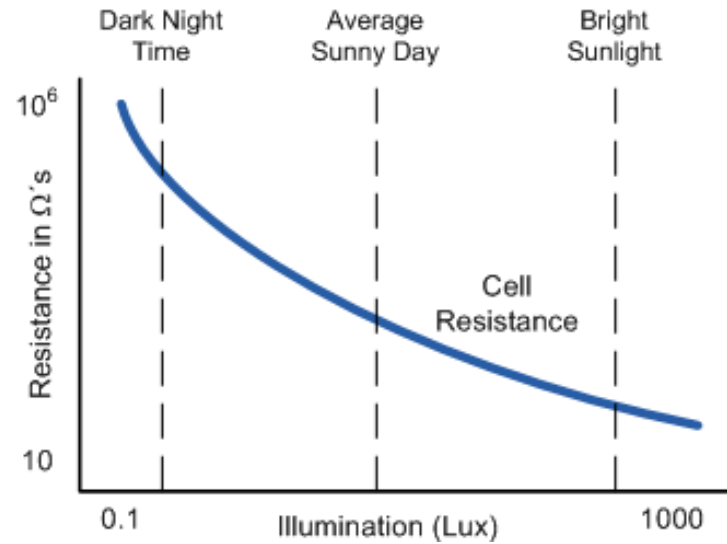

Light level sensitive switch

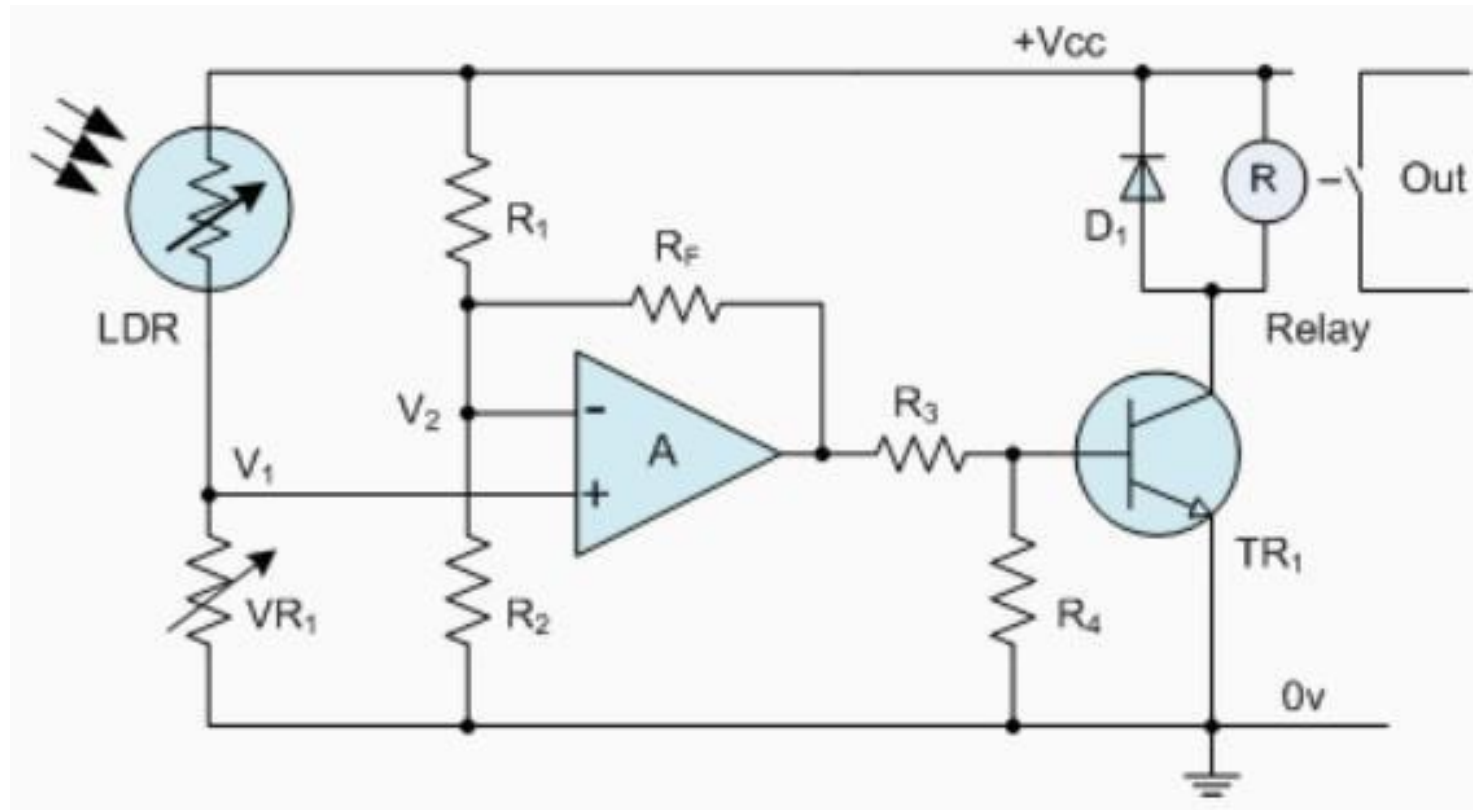

Photojunction devices

photodiode

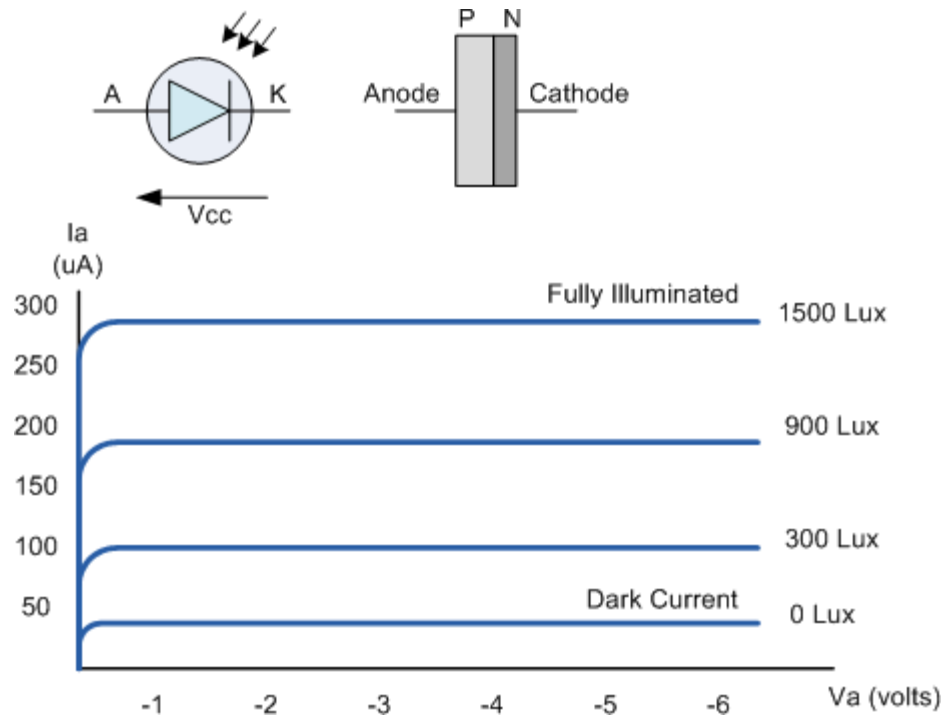

phototransistor

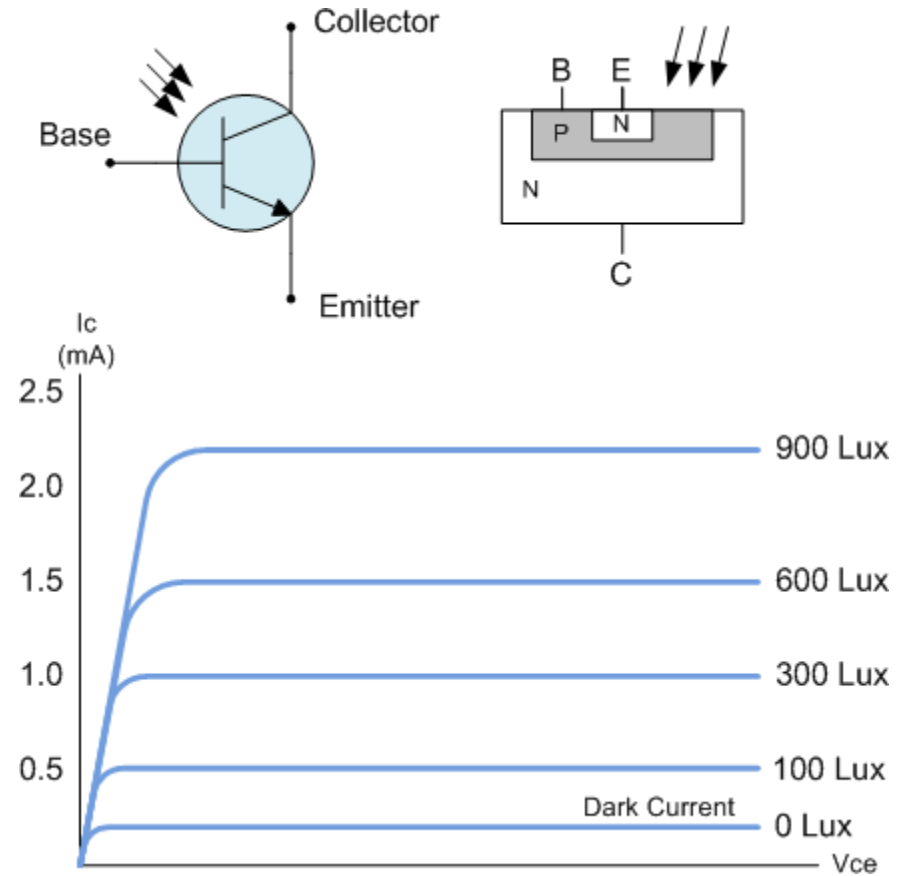

Photovoltaic Solar

Cells

- Can convert about 20% of light power into electricity
- Voltage is low (diode drop, $\sim 0.6\text{V}$)

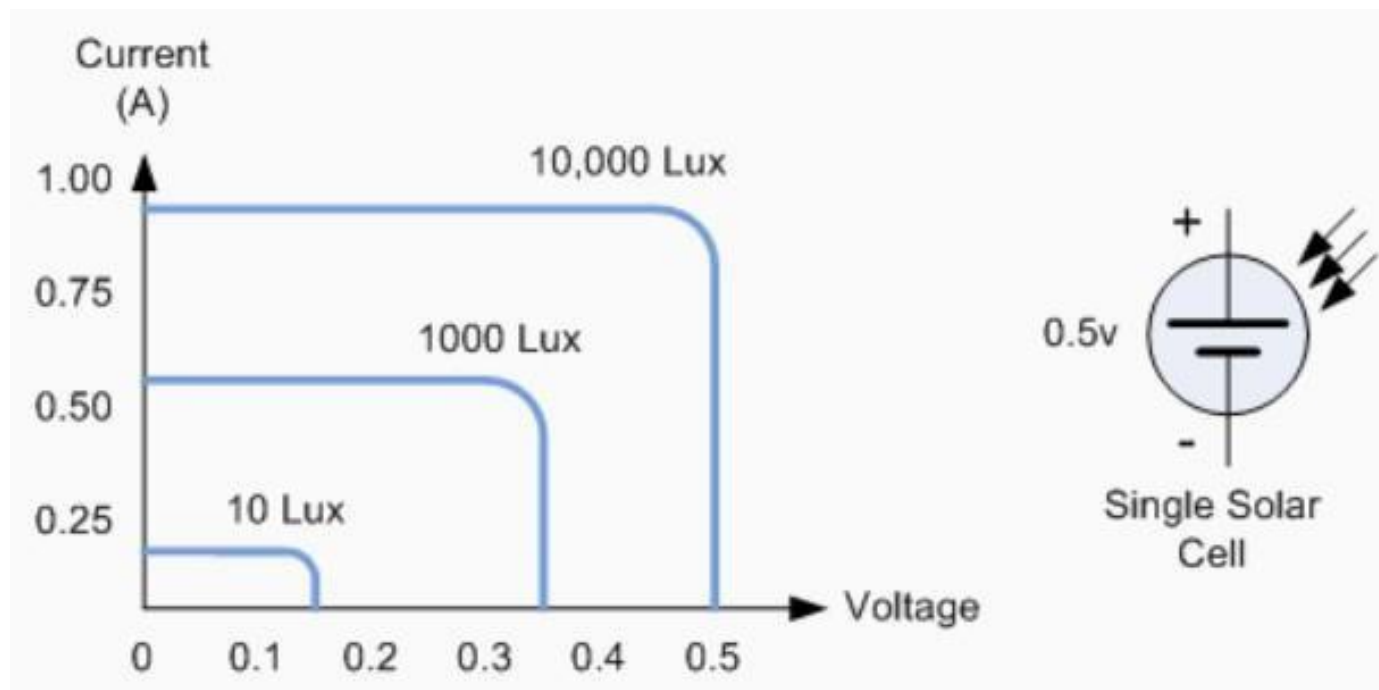

Solar power is 1.4kW/m^2

Photomultiplier tubes

- **(PMTs)** sensitive of light sensors (can detect individual photons)
- Acts as a current source

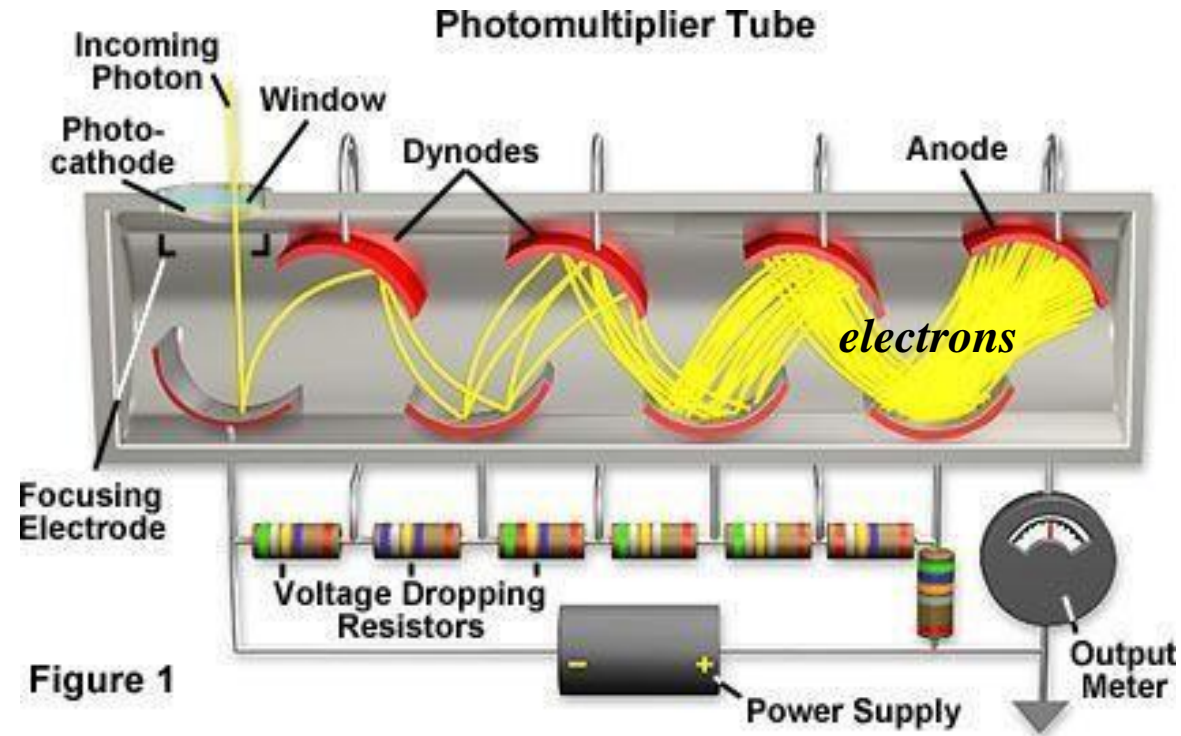

Sound transduce

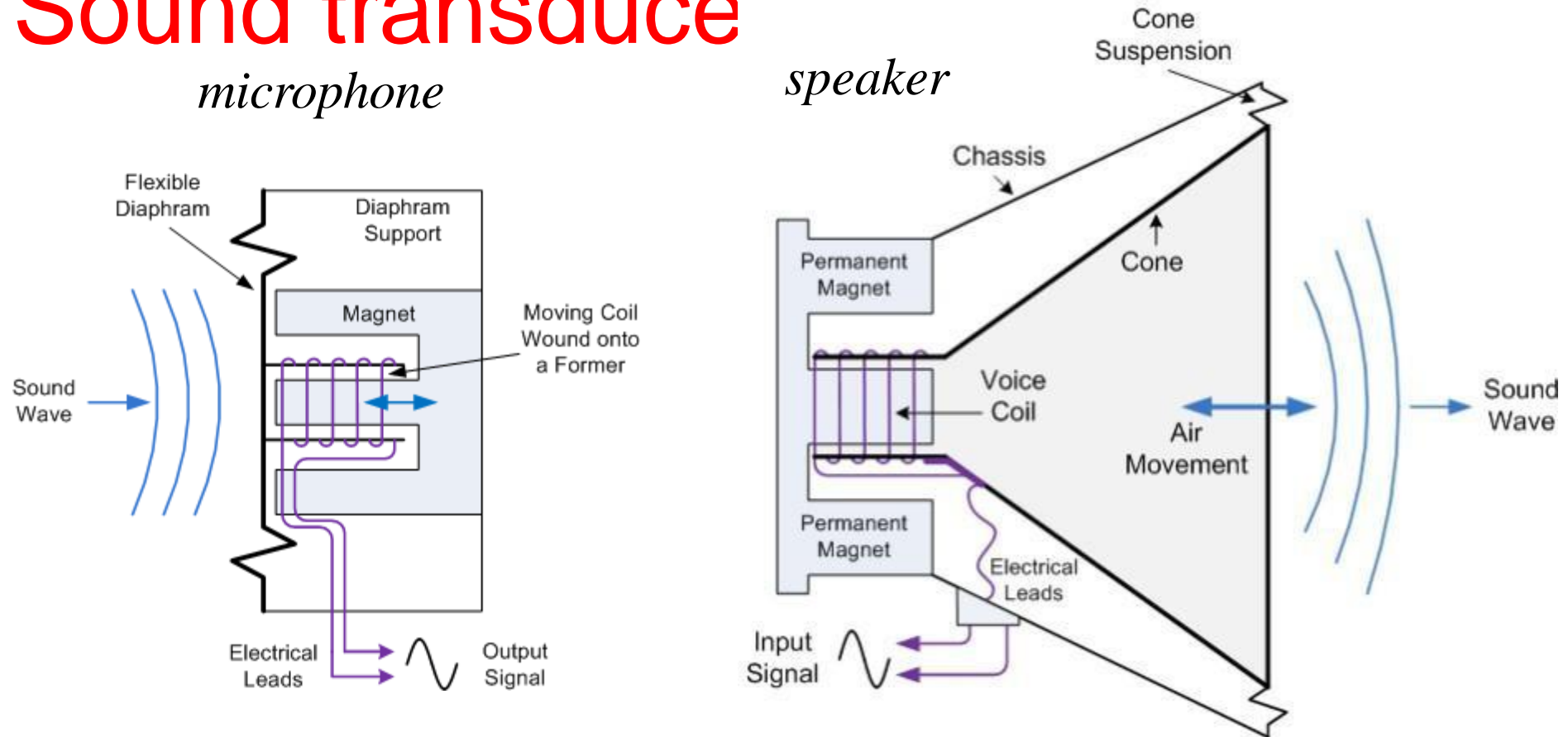

- Note: voice coil can also be used to generate fast motion

UNIT-V

Bridges, Measurement of Physical parameters

Introduction to Bridge.

- Bridge circuits are the instruments for making comparisons measurements, are widely used to measure resistance, inductance, capacitance and impedance.
- Bridge circuits operate on a *null-indication principle*, the indication is independent of the calibration of the indicating device or any characteristics of it. It is very accurate.

The Wheatstone Bridge.

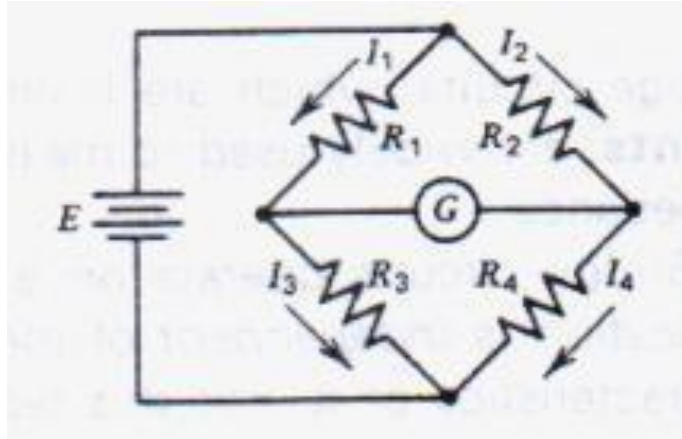

- ✘ The Wheatstone bridge consists of **two parallel resistance** branches with each branch containing two series resistor elements.
- ✘ A DC voltage source is connected across the resistance network to provide a source of current through the resistance network.
- ✘ A **null detector** is the galvanometer which is connected between the parallel branches to detect the **balance condition**.
- ✘ The Wheatstone bridge is an **accurate** and **reliable** instrument and heavily used in the industries.

The Wheatstone Bridge.

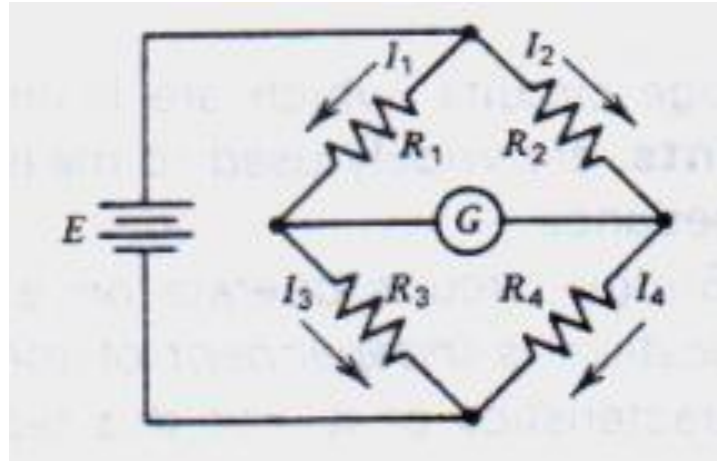

✘ Operation

(i) We want to know the **value of R_4** , vary one of the remaining resistor until the current through the null detector decreases to **zero**.

(ii) the bridge is in balance condition, the voltage across resistor R_3 is equal to the voltage drop across R_4 .

✘ At balance the voltage drop at R_1 and R_2 must be equal to.

$$I_3 R_3 = I_4 R_4$$

Cont'd...

- ⊗ **No current** go through the galvanometer G, the bridge is in balance so,

$$I_1 R_1 = I_2 R_2$$

$$I_1 = I_3$$

$$I_2 = I_4$$

- ⊗ This equation, $R_1 R_4 = R_2 R_3$, states the condition for a balance Wheatstone bridge and can be used to compute the value of unknown resistor.

$$I_1 R_3 = I_2 R_4$$

$$\frac{R_1}{R_3} = \frac{R_2}{R_4}$$

or

$$R_1 R_4 = R_2 R_3$$

Example 5.1: Wheatstone Bridge.

Determine the value of unknown resistor, R_x in the circuit.

assuming a null exist ; current through the galvanometer is zero.

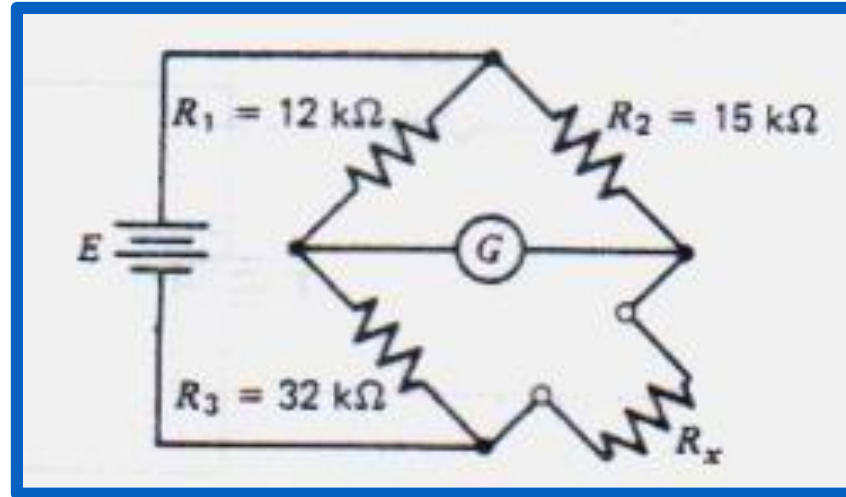

Solution:

From the circuit, the product of the resistance in opposite arms of the bridge is balance, so solving for R_x

$$R_x R_1 = R_2 R_3$$

$$\begin{aligned} R_x &= \frac{R_2 R_3}{R_1} \\ &= \frac{15K\Omega * 32K\Omega}{12K\Omega} = \end{aligned}$$

Sensitivity of the Wheatstone Bridge.

- ✘ When the bridge is in *unbalance condition*, current flows through the galvanometer causing a *deflection of its pointer*.
- ✘ The *amount of deflection* is a function of the *sensitivity* of the galvanometer.
- ✘ Sensitivity is the deflection per unit current.
- ✘ The *more sensitive* the galvanometer will *deflect more* with the same amount of current.

$$S = \frac{\text{millimeters}}{\mu A} = \frac{\text{degrees}}{\mu A} = \frac{\text{radian}}{\mu A}$$

Total deflection,

$$D = SI$$

Unbalanced Wheatstone Bridge.

- The current flows through the galvanometer can determine by using **Thevenin theorem**.

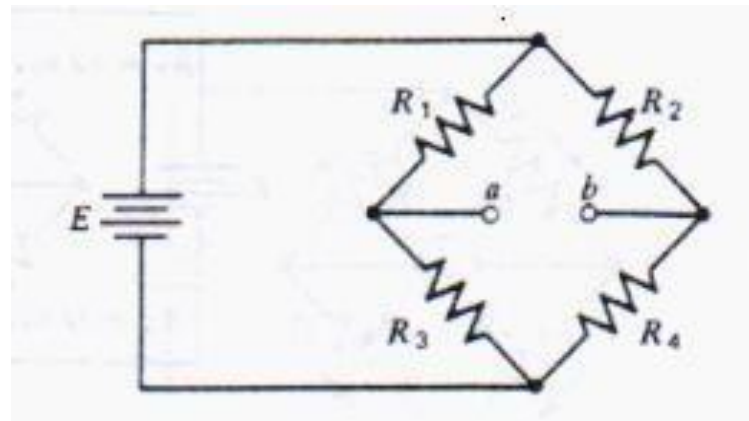
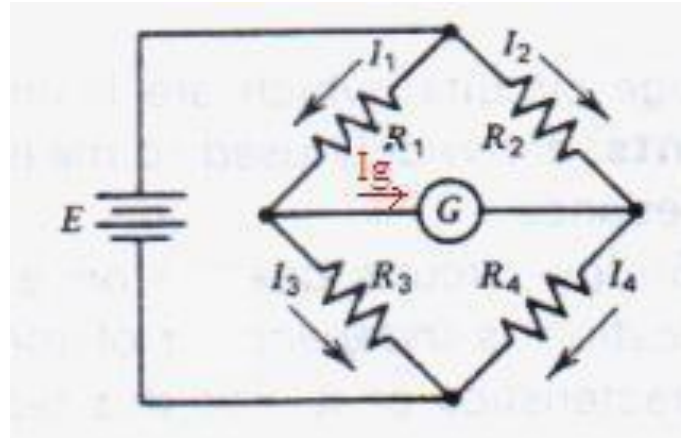

$$R_{Th} = R_{ab} = (R_1 // R_3) + (R_2 // R_4)$$

$$V_{Th} = V_{ab} = E \left(\frac{R_3}{R_1 + R_3} \right) - E \left(\frac{R_4}{R_2 + R_4} \right)$$

Unbalanced Wheatstone Bridge.

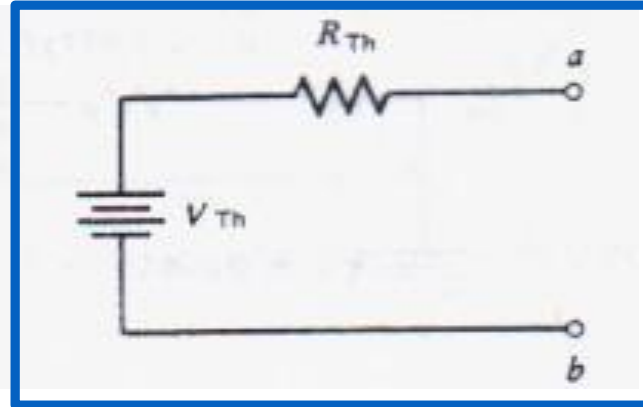

The deflection current in the galvanometer is

$$I_g = \frac{V_{th}}{R_{th} + R_g}$$

R_g = the internal resistance in the galvanometer

Kelvin Bridge.

- ✘ The Kelvin Bridge is the modified version of the Wheatstone Bridge.
- ✘ The modification is done to *eliminate* the effect of *contact* and *lead resistance* when measuring unknown low resistance.
- ✘ By using Kelvin bridge, resistor within the range of *1 Ω to approximately 1 μΩ* can be measured with high degree of accuracy.
- ✘ Figure below is the basic Kelvin bridge. The resistor *R_{ic}* represent the lead and contact resistance present in the Wheatstone bridge.

Cont'd...

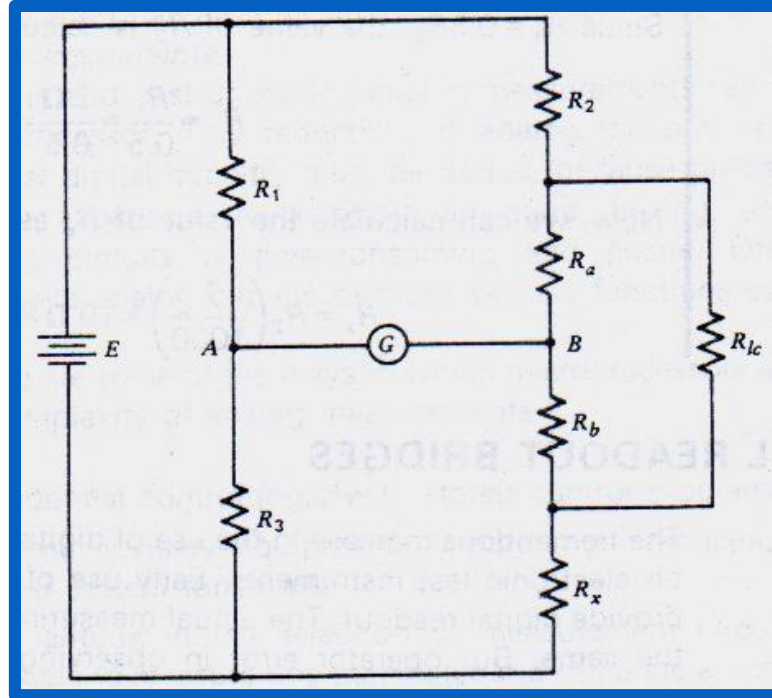

Full Wave Bridge Rectifier Used in AC Voltmeter Circuit.

- ✘ The second set of R_a and R_b compensates for this relatively low lead contact resistance
- ✘ At balance the ratio of R_a and R_b must be equal to the ratio of R_1 to R_3 .

$$R_x = \frac{R_2 R_3}{R_1}$$
$$R_x = \frac{R_3}{R_2} R_1$$
$$R_x = \frac{R_3}{R_1} = \frac{R_b}{R_a}$$

Example : Kelvin Bridge.

Figure below is the Kelvin Bridge, the ratio of R_a to R_b is 1000. R_1 is 5 Ohm and $R_1 = 0.5 R_2$.

Find the value of R_x .

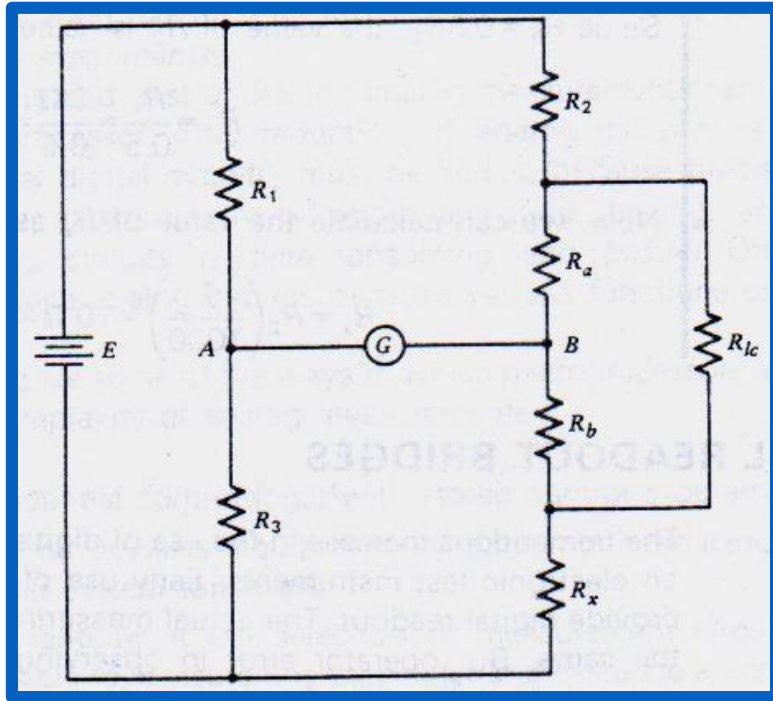

Solution:

Calculate the resistance of R_x ,

$$\frac{R_x}{R_2} = \frac{R_b}{R_a} = \frac{1}{1000}$$

$R_1 = 0.5 R_2$, so calculate R_2

$$R_2 = \frac{R_1}{0.5} = \frac{5\Omega}{0.5} = 10\Omega$$

Calculate the value of R_x

$$\begin{aligned} R_x &= R_2 \left(\frac{1}{1000} \right) \\ &= 10\Omega \left(\frac{1}{1000} \right) \\ &= 0.01\Omega \end{aligned}$$

Introduction to AC Bridge.

- ❌ AC bridge are used to measure *impedances*.
- ❌ All the AC bridges are based on the Wheatstone bridge.
- ❌ In the AC bridge the bridge circuit consists of *four impedances* and an *ac voltage source*.
- ❌ The impedances can either be pure resistance or complex impedance.

General impedance bridge

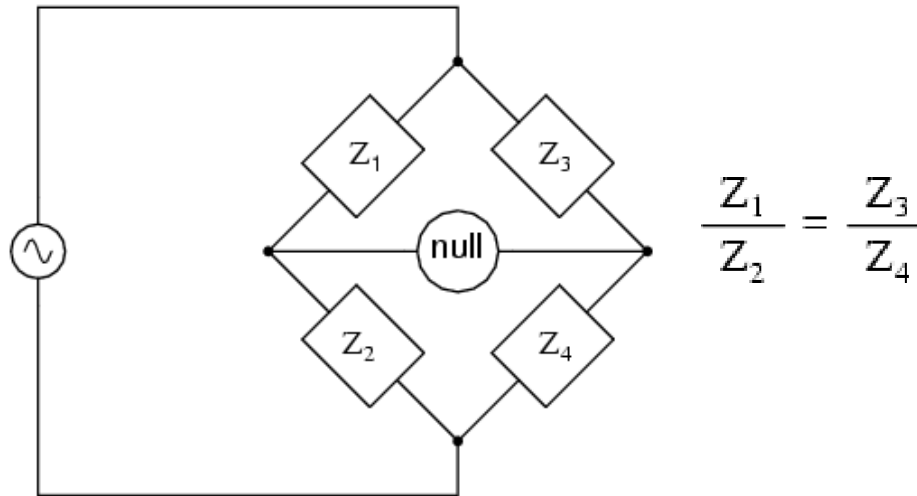

A box with a "Z" written inside is the symbol for any nonspecific impedance.

Cont'd...

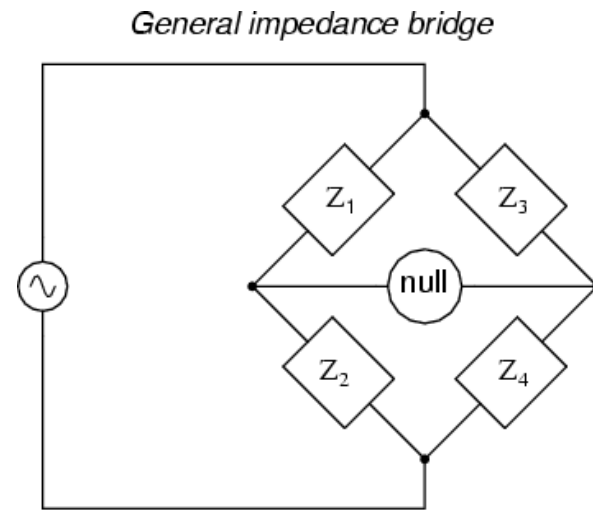

A box with a "Z" written inside is the symbol for any nonspecific impedance.

- ✘ When the specific circuit conditions apply, the detector current becomes zero, which is known as **null** or **balance zero**.
- ✘ bridge circuits can be constructed to measure about any device value desired, be it capacitance, inductance, resistance
- ✘ the unknown component's value can be determined directly from the setting of the calibrated standard value

A simple bridge circuits are shown below;

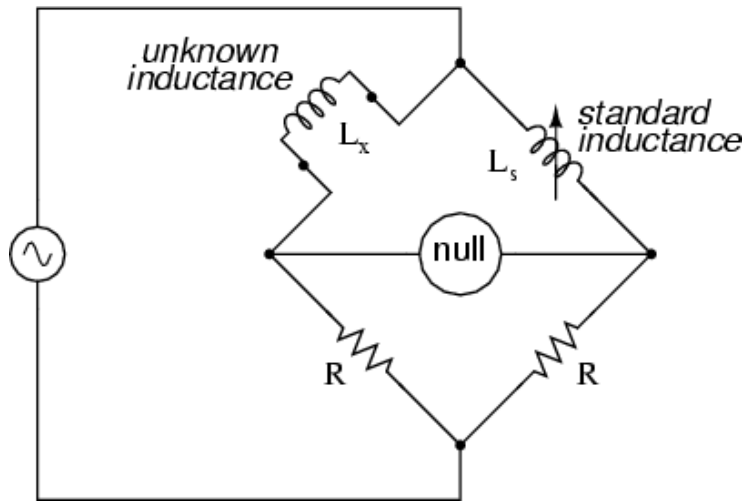

inductance

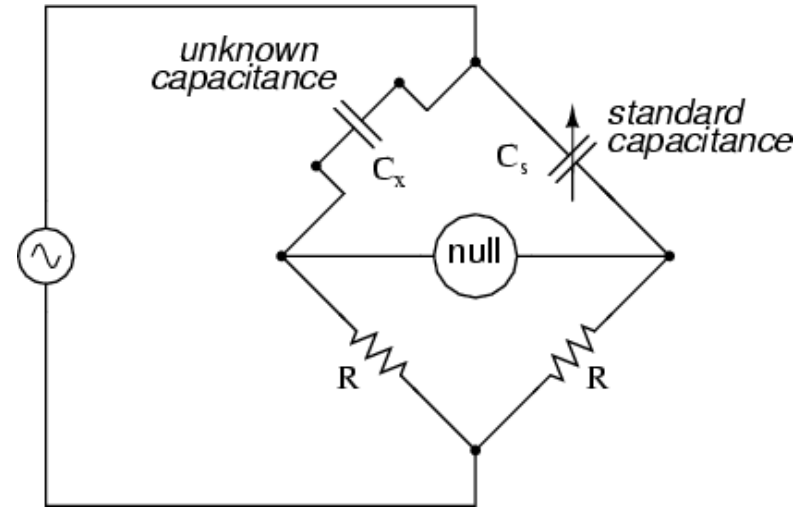

capacitance

Similar angle Bridge.

- ❌ used to measure the impedance of a capacitance circuit.
- ❌ Sometimes called the capacitance comparison bridge or series resistance capacitance bridge

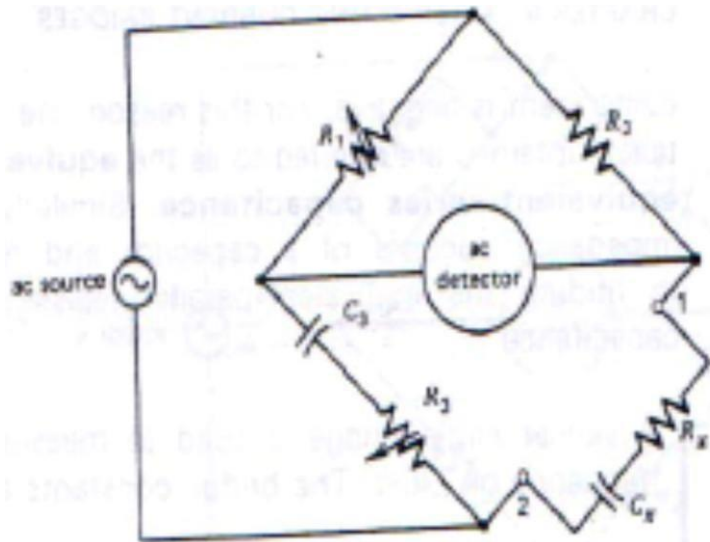

$$R_x = \frac{R_2}{R_1} R_3$$

$$C_x = \frac{R_1}{R_2} C_3$$

Opposite angle Bridge.

- ✘ From similar angle bridge, capacitor is replaced by inductance
- ✘ used to measure the impedance of a inductive circuit.
- ✘ Sometimes called a Hay bridge

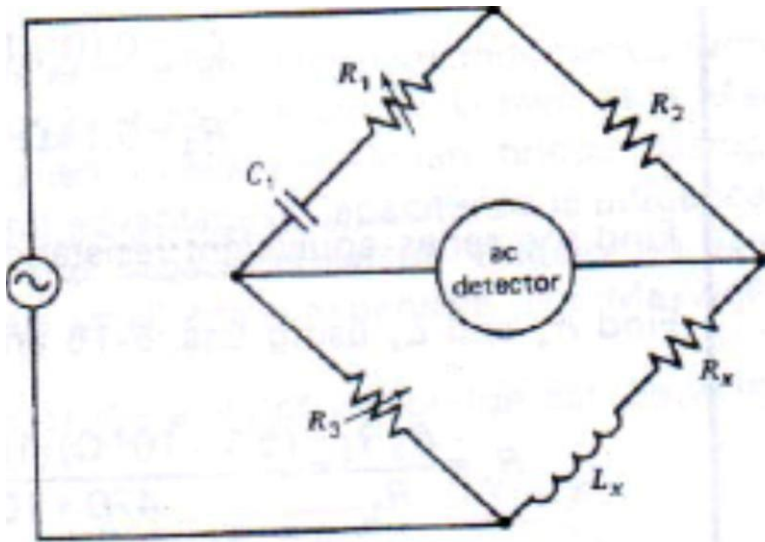

$$R_x = \frac{\omega^2 R_2 R_3 R_1 C_1^2}{1 + \omega^2 R_1^2 C_1^2}$$
$$L_x = \frac{R_2 R_3 C_1}{1 + \omega^2 R_1^2 C_1^2}$$

Wien Bridge.

- ✘ uses a parallel capacitor-resistor standard impedance to balance out an unknown series capacitor-resistor combination.
- ✘ All capacitors have some amount of internal resistance.

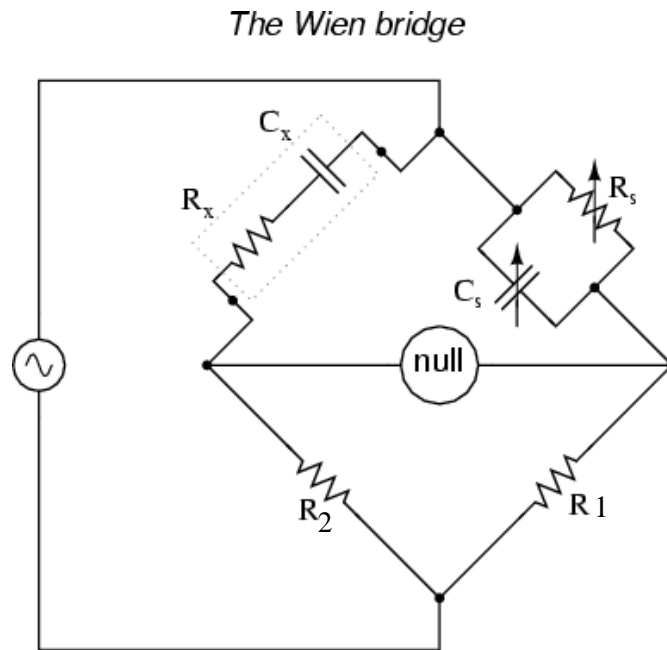

$$R_s = \frac{R_1}{R_2} \left(R_x + \frac{1}{\omega^2 R_x C_x^2} \right)$$
$$C_s = \frac{R_2}{R_1} \left(\frac{1}{1 + \omega^2 R_x^2 C_x^2} \right) C_x$$

$$R_x = \frac{R_2}{R_1} \left(\frac{R_s}{1 + \omega^2 R_s^2 C_s^2} \right)$$
$$C_x = \frac{R_1}{R_2} \left(C_s + \frac{1}{\omega^2 R_s^2 C_s^2} \right)$$

Maxwell-Wien Bridge.

- ✘ used to measure unknown inductances in terms of calibrated resistance and capacitance.
- ✘ Because the phase shifts of inductors and capacitors are exactly opposite each other, a capacitive impedance can balance out an inductive impedance if they are located in opposite legs of a bridge
- ✘ Sometimes called a Maxwell bridge
The Maxwell-Wien bridge

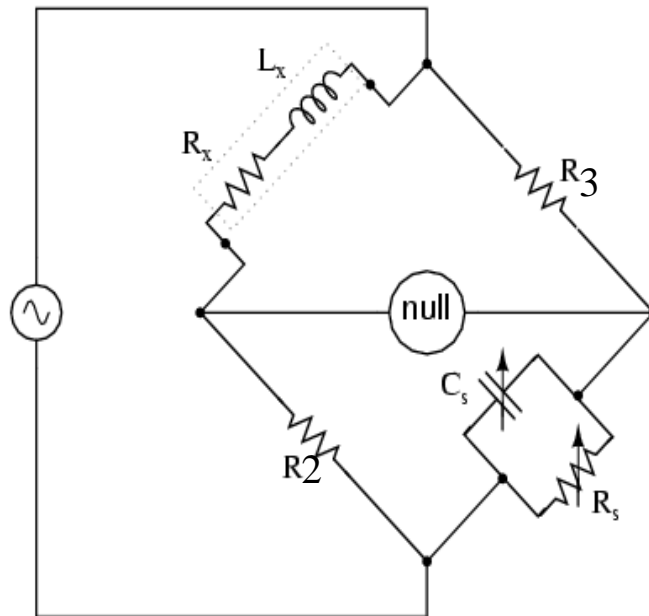

$$R_x = \frac{R_2 R_3}{R_s}$$

$$L_x = R_2 R_3 C_s$$

**Please
prove it !!!**

Measurement of Physical parameters

Transducer

- Transducer is defined as a device which convert energy or information from one form to another. Transducer may be mechanical, electrical, magnetic, optical, chemical, thermal or combination of two or more of these.

- quantities to be measured are non-electrical such as temperature, pressure, displacement, humidity, fluid flow, speed, pH, etc., but these quantities cannot be measured directly. Hence such quantities are required to be sensed and changed into some other form of quantities.
- Therefore, for measurement of non-electrical quantities these are to be converted into electrical quantities (because these are easily measurable). This conversion is done by device called Electrical Transducer

Classification of transducers

1. Based on principle of transduction
2. Active & passive
3. Analog & digital
4. Inverse transducer

Based on principle used

- Thermo electric
- Magneto resistive
- Electro kinetic
- Optical

Passive transducer

Device which need external power for transduction from auxiliary power source

Eg : resistive, inductive, capacitive
Without power they will not work

Active transducer

- No extra power required.
- Self generating
- Draw power from input applied
- Eg. Piezo electric x'tal used for acceleration measurement

Resistive Transducer

- In this transducer, the resistance of the output terminal of the transducer gets varied according to the measurand.
- Some resistive transducers are:-

Potentiometer

Strain gauge

Resistance Thermometer

RESISTIVE POTENTIOMETERS

A resistance element provided with a movable contact. This is very simple and cheap form of transducer and is widely used. It convert linear or rotational displacement into a voltage.

The contact motion can be

- Linear
- rotation
- combination of the two such as helical

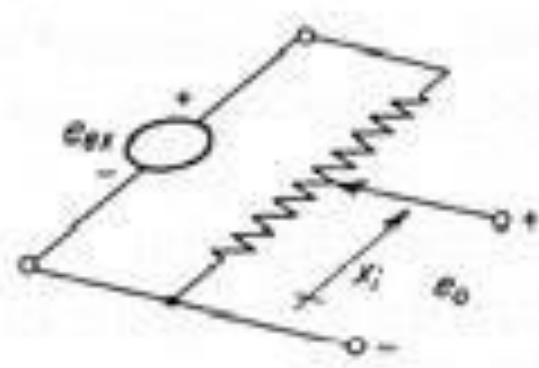

Translational

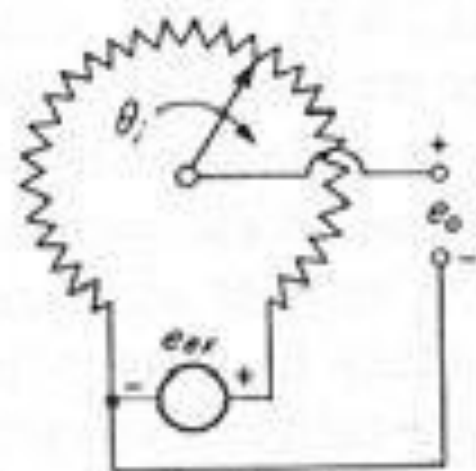

Single-turn

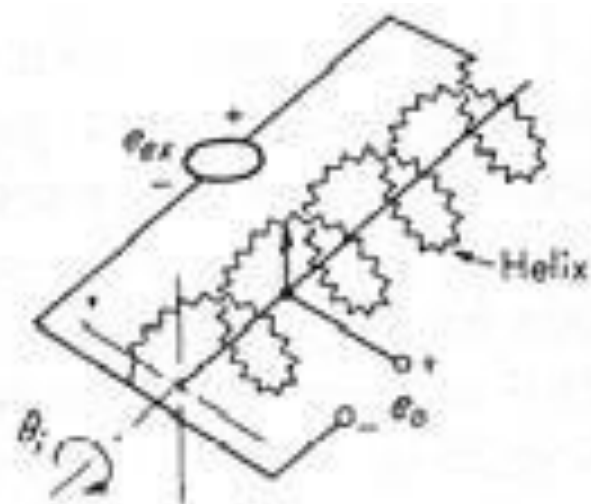

Multiturn

Rotational

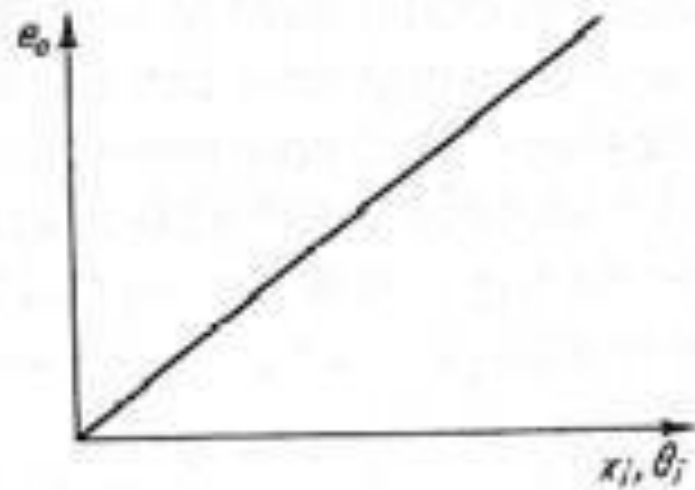

Strain

Gauge It is a device which is used for measuring mechanical surface strain and one of the most extensively used electrical transducer. It can detect and convert force or small mechanical displacement into electrical signal. Many other quantities such as torque, pressure, weight and tension etc, which involve the effect of force or displacement can be measured with string gauge.

- Gauge Factor (G) = Change in resistance per unit strain.

Strain Gauge can be of four types:-

1. Wire strain gauge
2. Foil strain gauge
3. Thin film strain gauge
4. Semiconductor strain gauge

INDUCTIVE TRANSDUCERS

- Inductive transducers are those in which SELF INDUCTANCE of a coil or the MUTUAL INDUCTANCE of a pair of coil is altered due to variation in the measurand.
- Change in inductance ΔL is measured.
- The **self inductance** of a coil refers to the flux linkage within the coil due to current in the same coil.
- **Mutual inductance** refers to the flux linkages in a coil due to current in adjacent coil.

Excitation

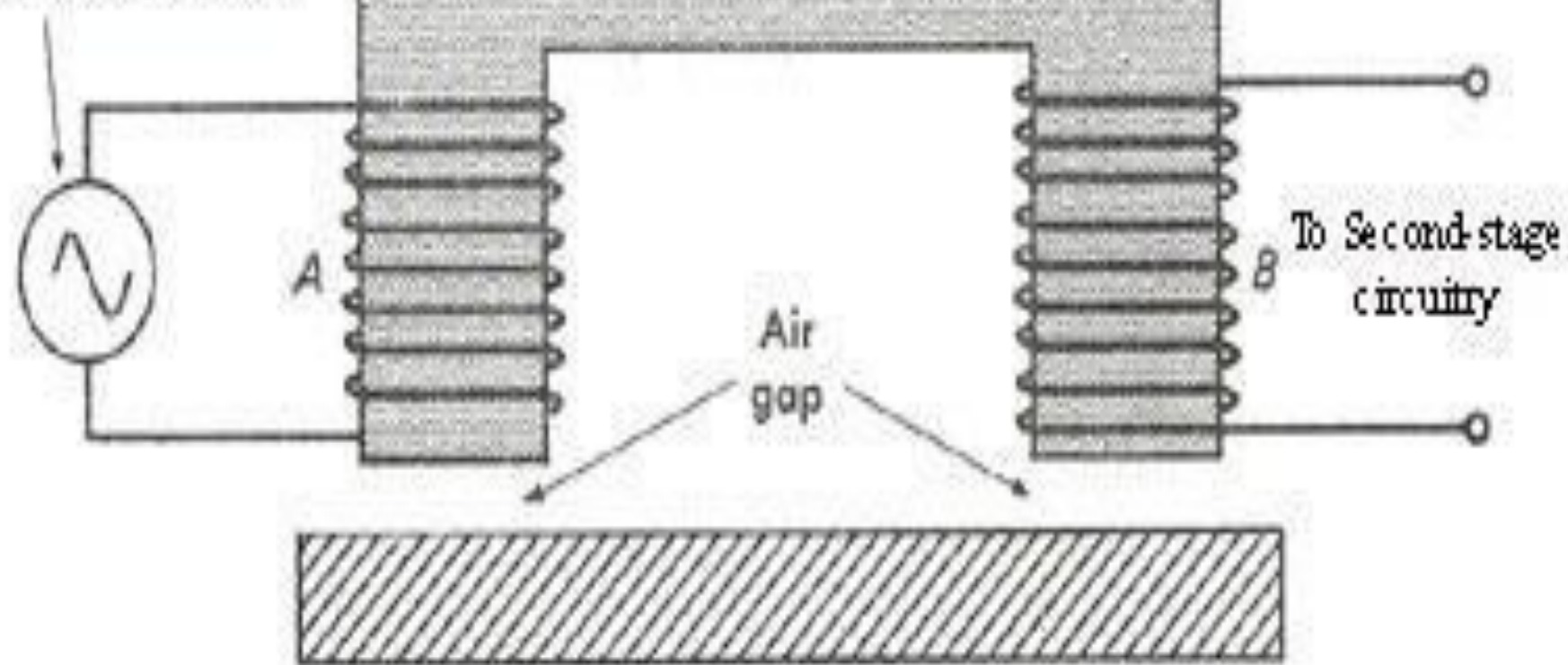

(b)

Armature
movement

CAPACITIVE TRANSDUCERS

A capacitor is an electrical component which essentially consists of two plates separated by an insulator.

The property of a capacitor to store an electric charge when its plates are at different potential is referred to as capacitance.

$$\text{Capacitance } C = \frac{Q}{V}$$

If the capacitance is large, more charge is needed to establish a given voltage difference.

The capacitance between two parallel metallic plates of area

$$C = \frac{\epsilon_0 \epsilon_r A}{d} \quad \left(\epsilon_0 = 8.85 \times 10^{-12} \frac{F}{m} \right)$$

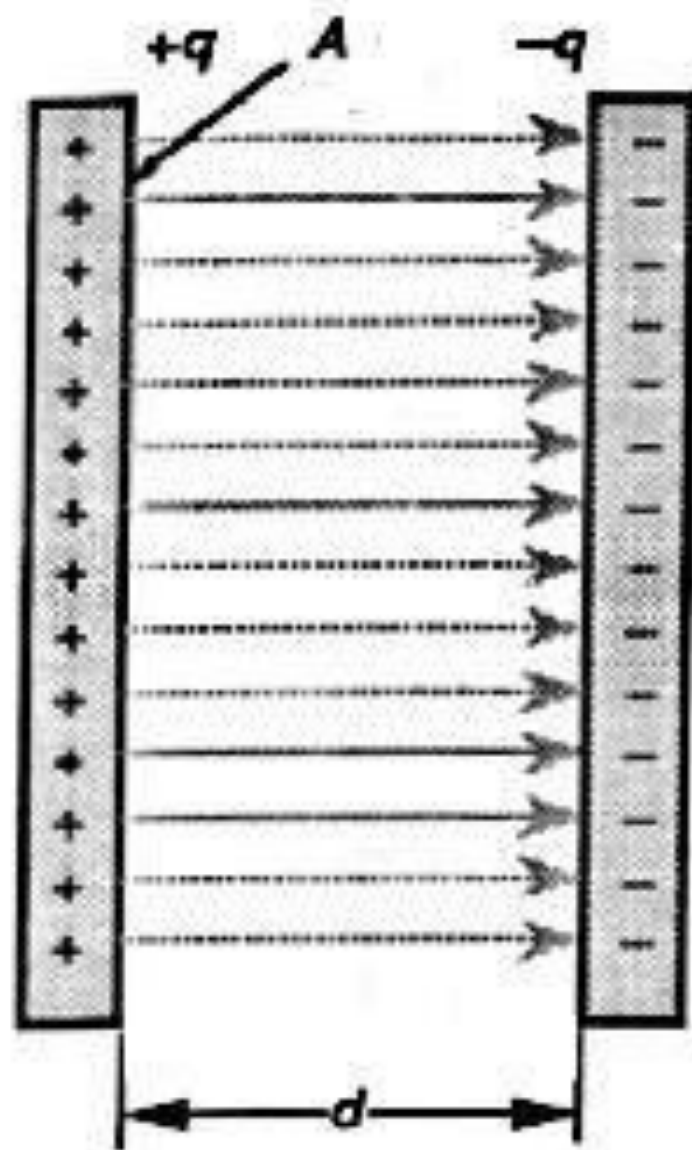

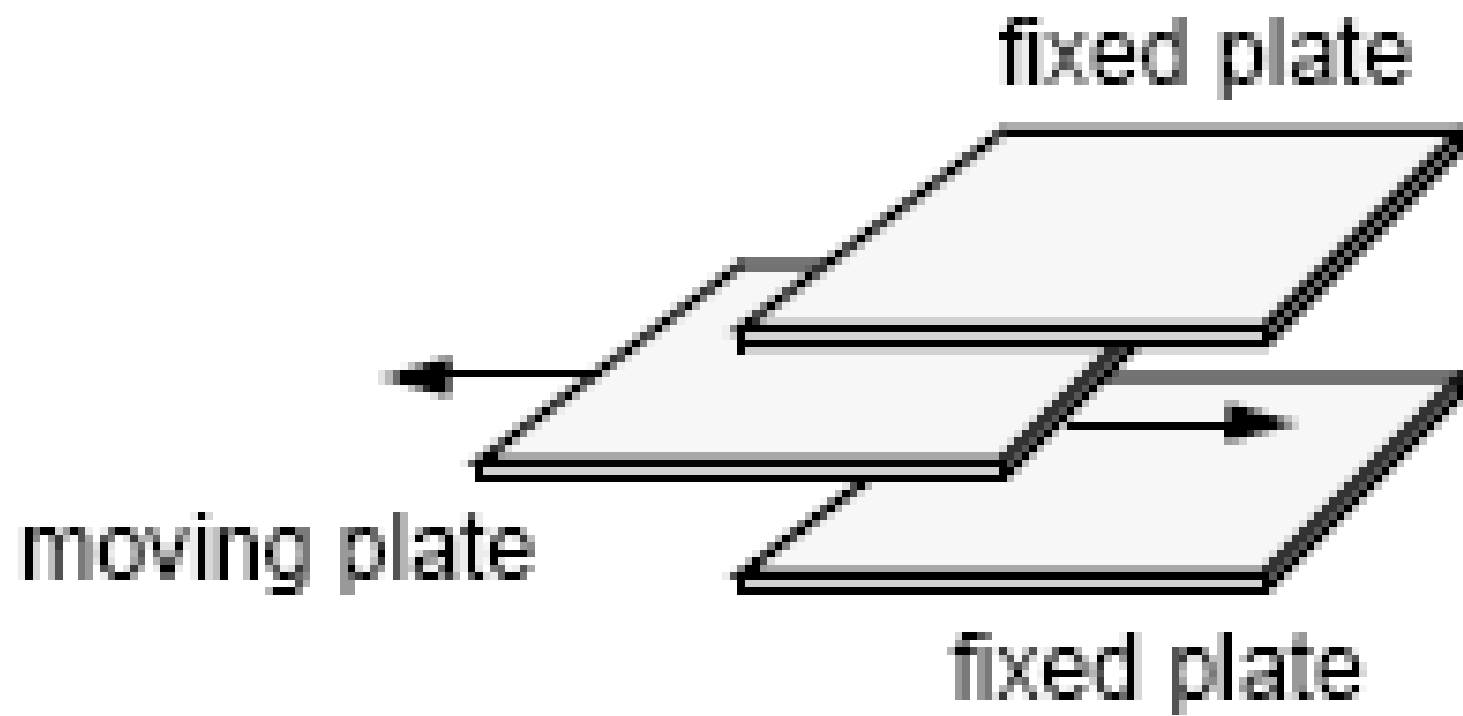

Linear Variable Differential Transformer (LVDT)

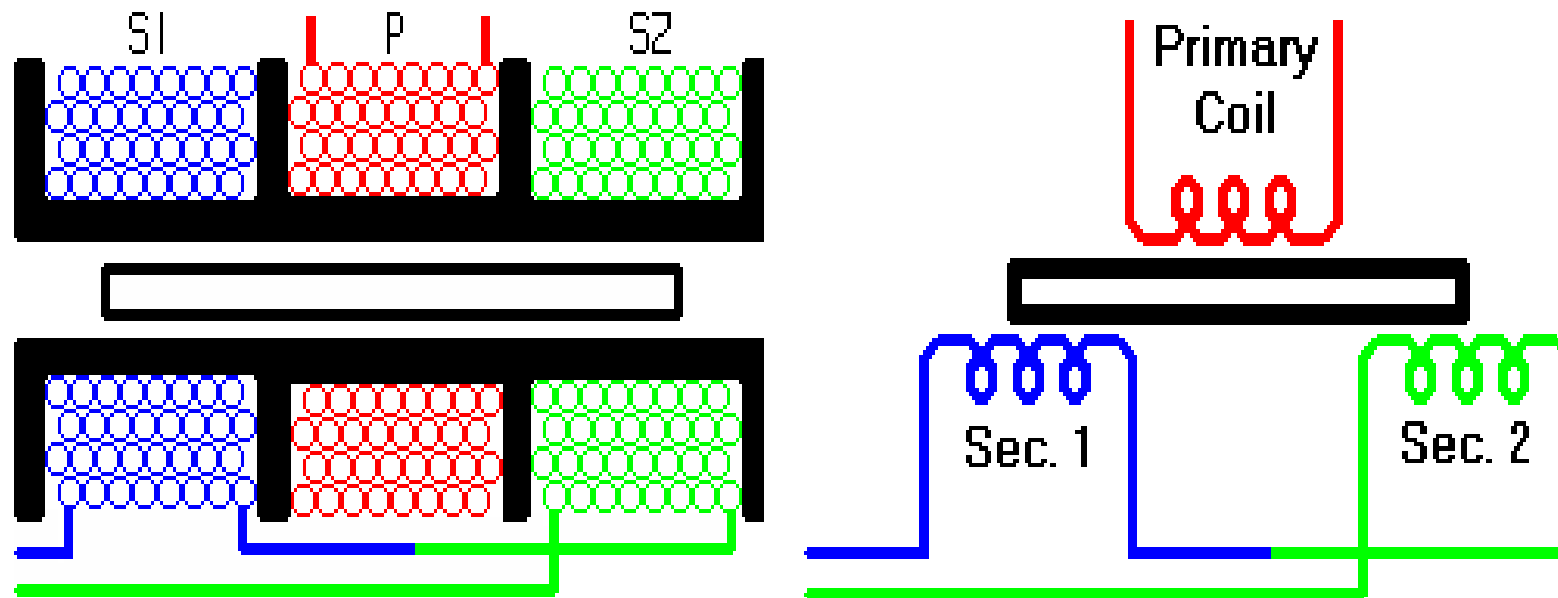

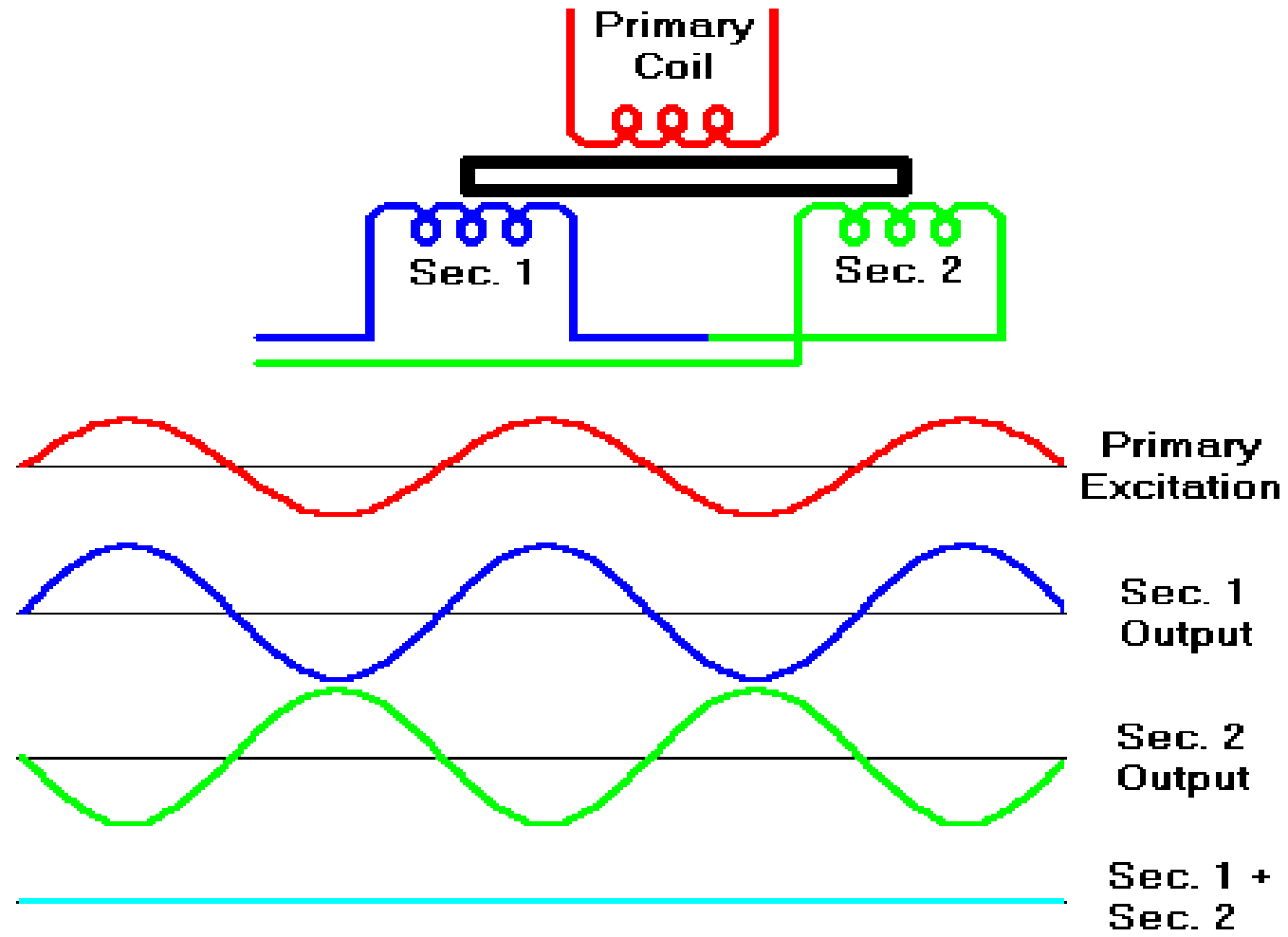

- There is one primary winding connected to an ac source (50 Hz – 20 kHz), excitation $3 - 15 V_{\text{rms}}$.
- Core is made of high permeability soft iron or nickel iron.
- Two secondary windings are connected in series opposition

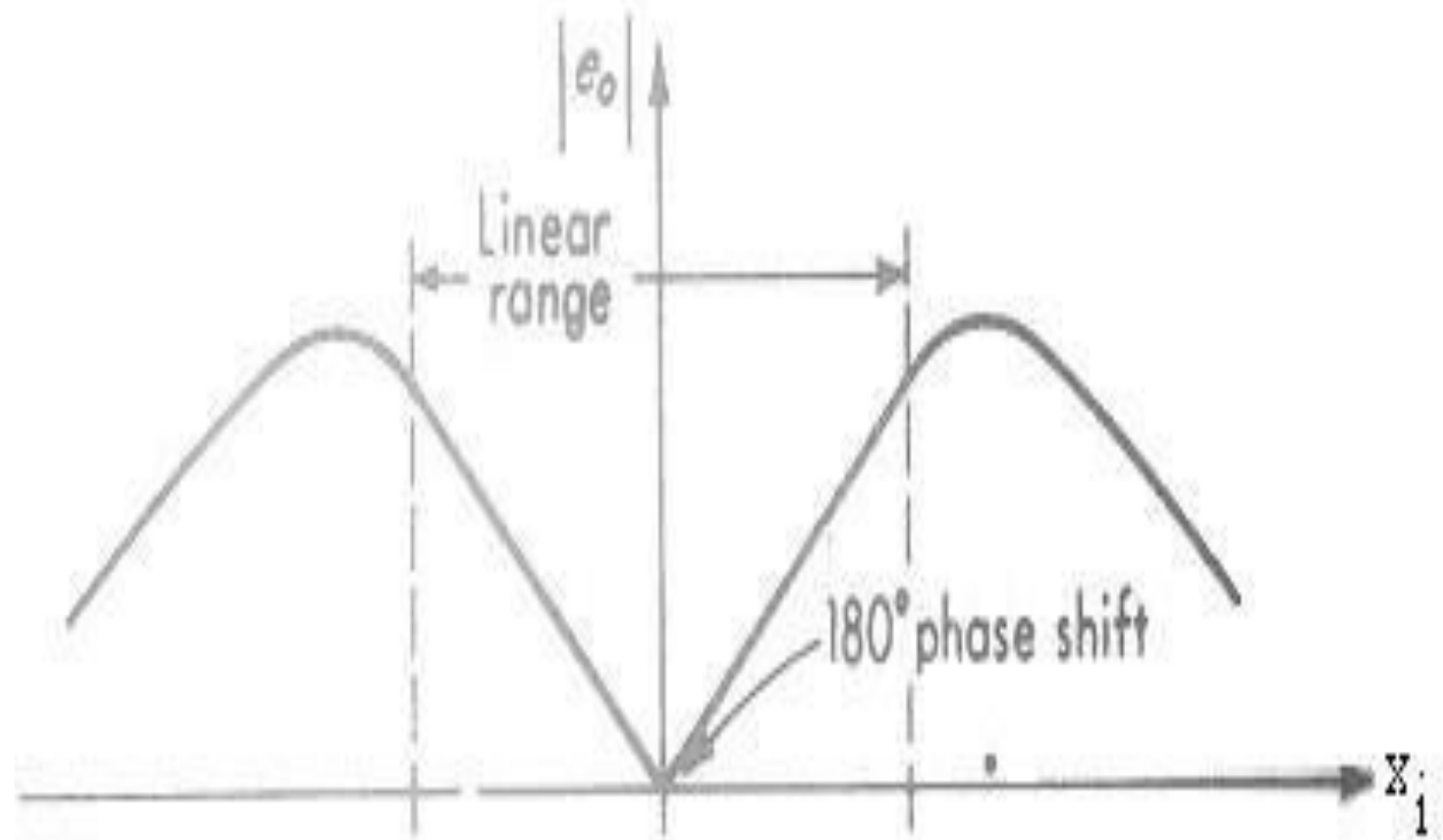

➤ Geometric centre of coil arrangement is called the NULL position. The output voltage at the null position is ideally zero.

➤ However it is small but nonzero (null voltage).

Why?

1. Harmonics in the excitation voltage and stray capacitance coupling between the primary and the secondary

2. Manufacturing defects.

Advantages

1. Wide range of displacement from μm to cm.
2. Frictionless and electrical isolation.
3. High output.
4. High sensitivity [sensitivity is expressed in mV (output voltage)/ mm (input core displacement)].

Disadvantages

1. Sensitive to stray magnetic fields.
2. Affected by vibrations.
3. Dynamic response is limited mechanically by the mass of core and electrically by frequency of excitation voltage.

Pressure Measurement

- The measurement of force or pressure can be done by converting the applied force or pressure into displacement by elastic element (such as diaphragm, capsule, bellows or bourdon tube) which act as primary transducer.
- This displacement, which is function of pressure is measured by transducer which act as secondary transducer (these may be potentiometer, strain gauge, LVDT, piezoelectric,etc.).

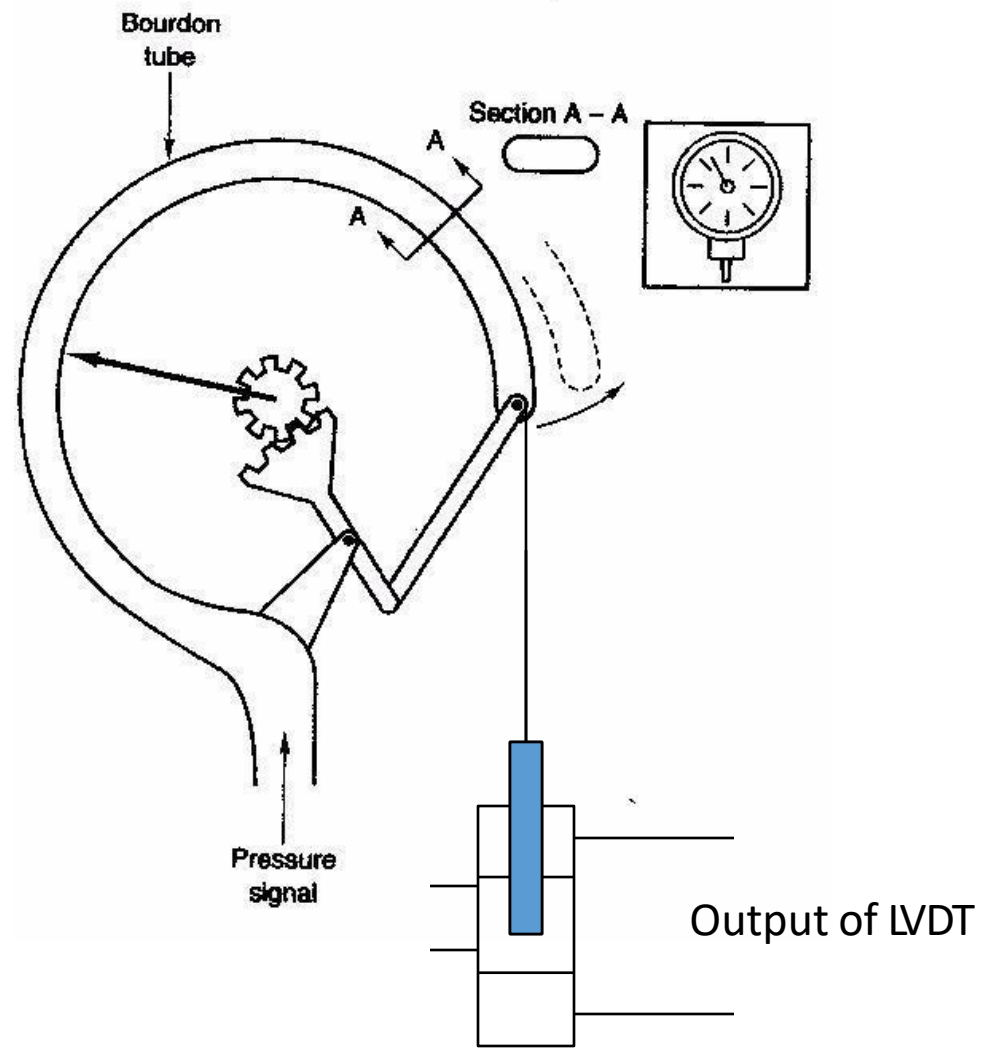

Bourdon Tube Pressure Gauge

- Perhaps the most common device around today is the pressure gauge which utilizes a bourdon tube as its sensing elements.
- ***Bourdon*** : A bourdon tube is a curved, hollow tube with the process pressure applied to the fluid in the tube. The pressure in the tube causes the tube to deform or uncoil. The pressure can be determined from the mechanical displacement of the pointer connected to the Bourdon tube. Typical shapes for the tube are —C|| (normally for local display), spiral and helical.

Bourdon Tube Pressure Gauge

Bourdon tubes are generally
are of three types;

1. C-type
2. Helical type
3. Spiral type

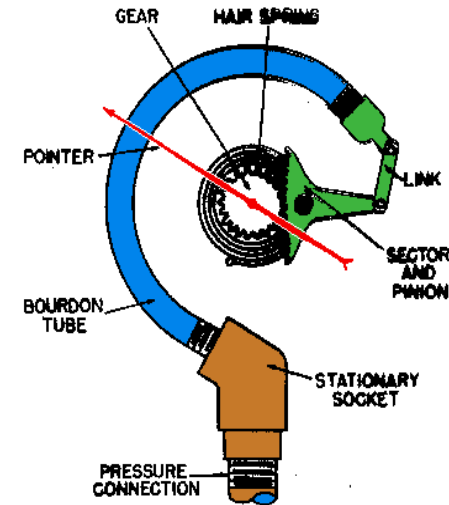
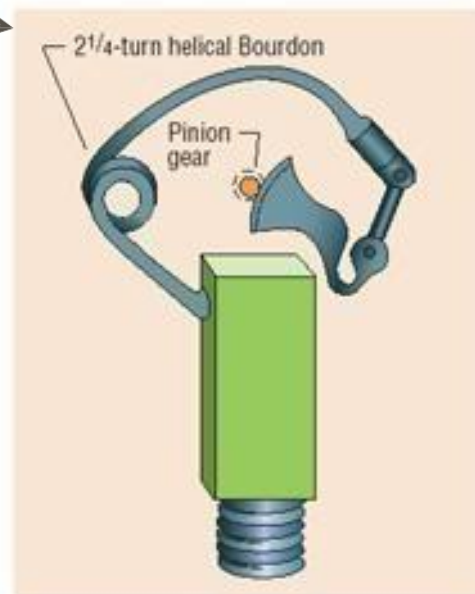
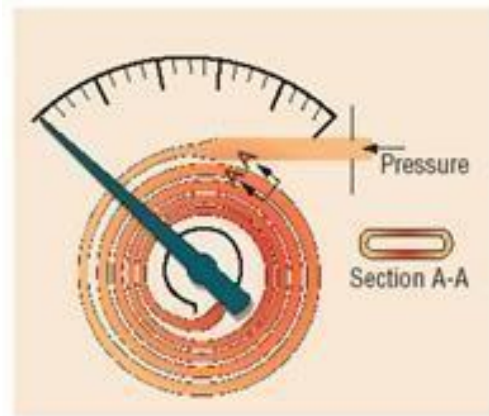

Thermo- couple



The thermocouple is one of the most commonly used method for measuring the process temperature. The operation is based on seebeck effect.

Thermo-couple consists of two dissimilar metals joined together as shown. It forms two junctions 1 and 2 in which one junction is hot and other is cold. Due to this difference in temperature, an e.m.f. is generated and electric current flow in circuit.

Electromagnetic flow meter consist of insulated electrodes pair buried in opposite sides of non conducting pipe placed in magnetic field of electromagnet.

The voltage induced across electrodes is $E=Blv$ volts

Liquid Level Measurement

- Gamma Ray Method

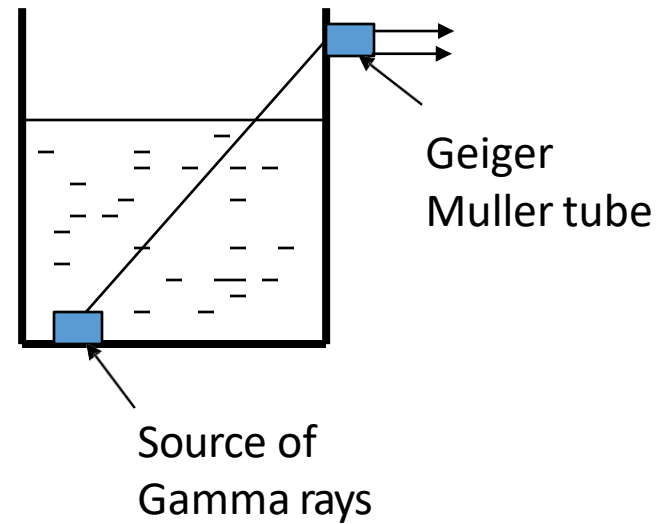

The liquid level can be measured with ultrasonic method and by using float also

**PIEZOELECTRIC
AND
HALL EFFECT TRANSDUCERS**

Piezoelectricity

Phenomenon of generating an electric charge in a material when subjecting it to a mechanical stress (direct effect).

and

Generating a mechanical strain in response to an applied electric field (converse effect).

Piezoelectric materials are *Anisotropic* – Electrical and mechanical properties differ along different directions

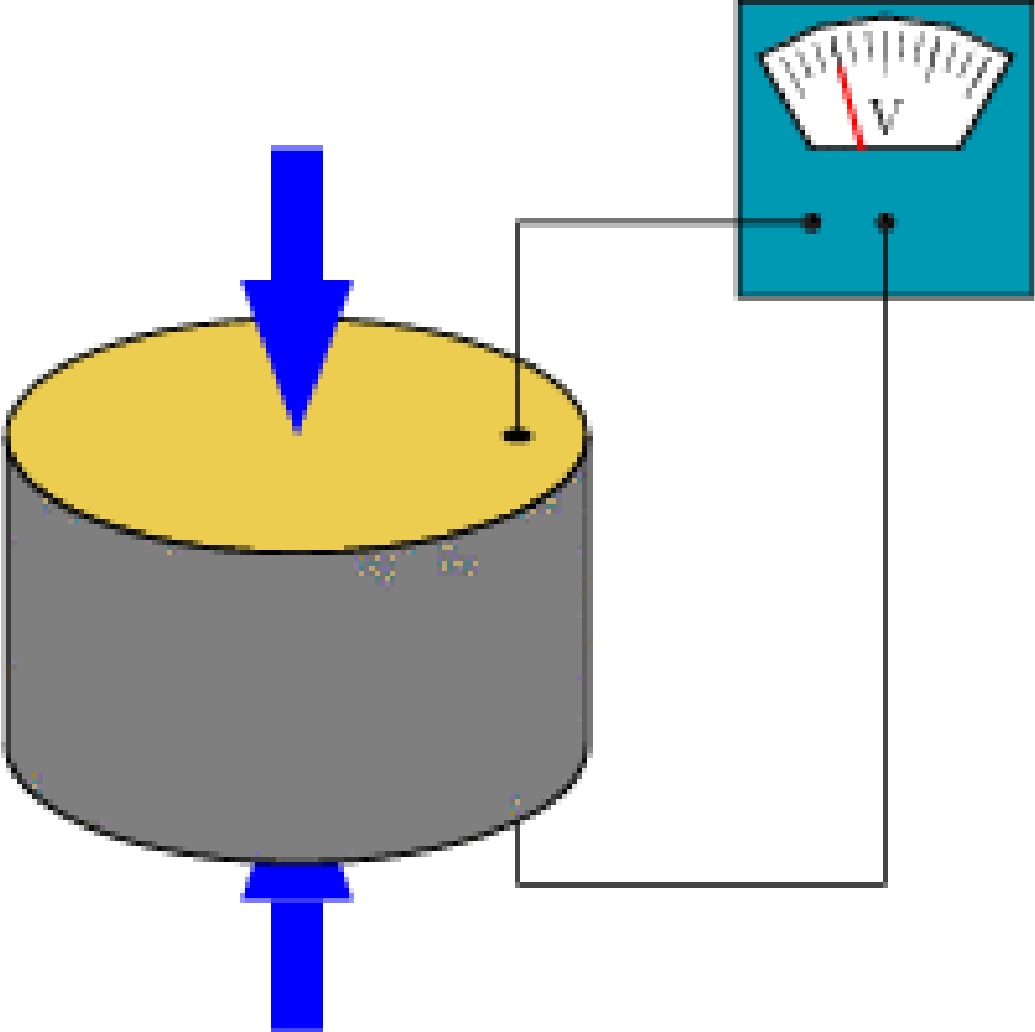

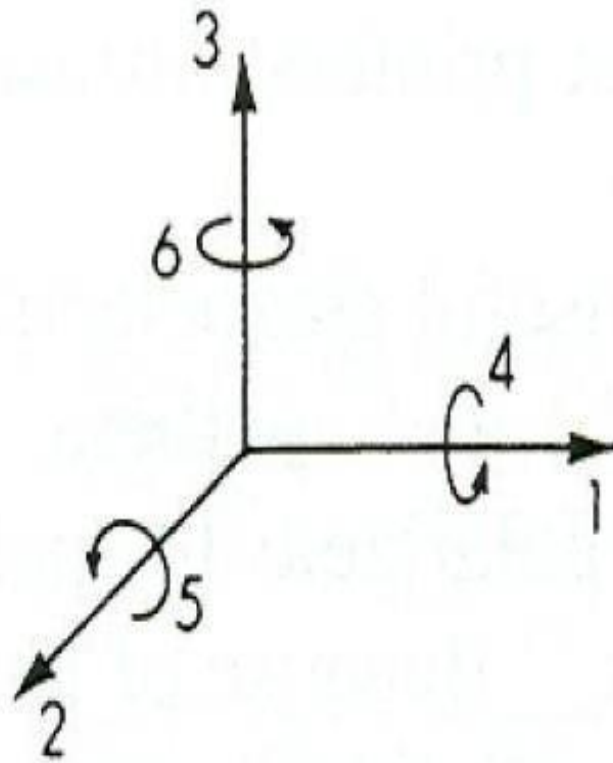

Axis system

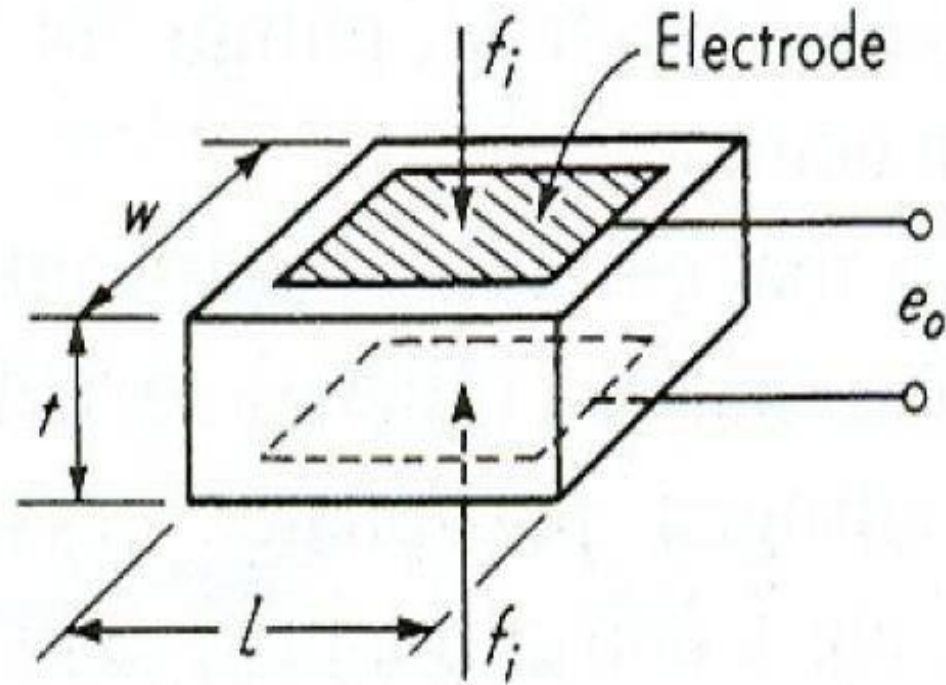

There are two families of constants: 'g' constants and 'd' constants. In the constants the first subscript refers to the direction of electrical effect and the second to that of the mechanical effect according to the axis systems.

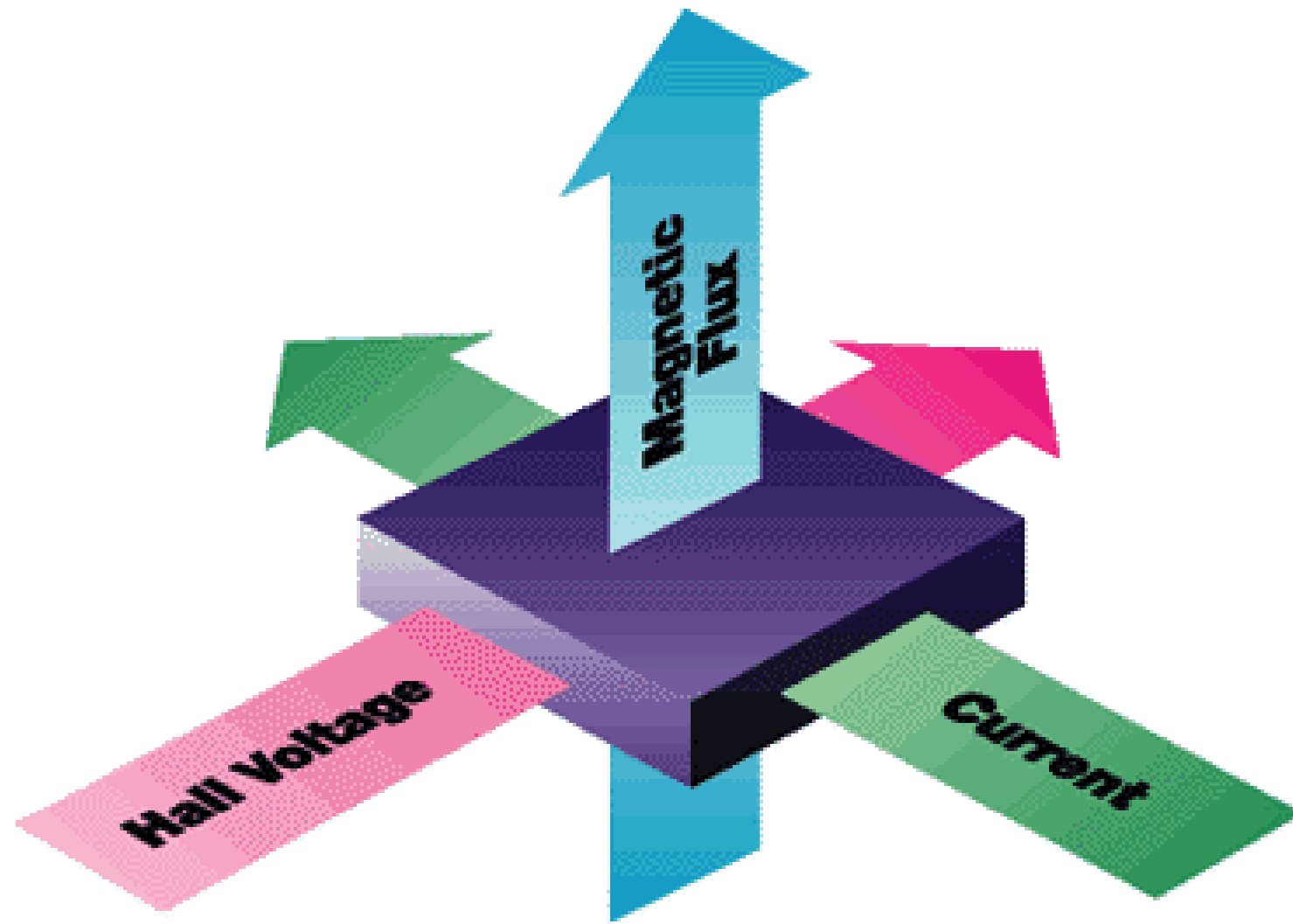

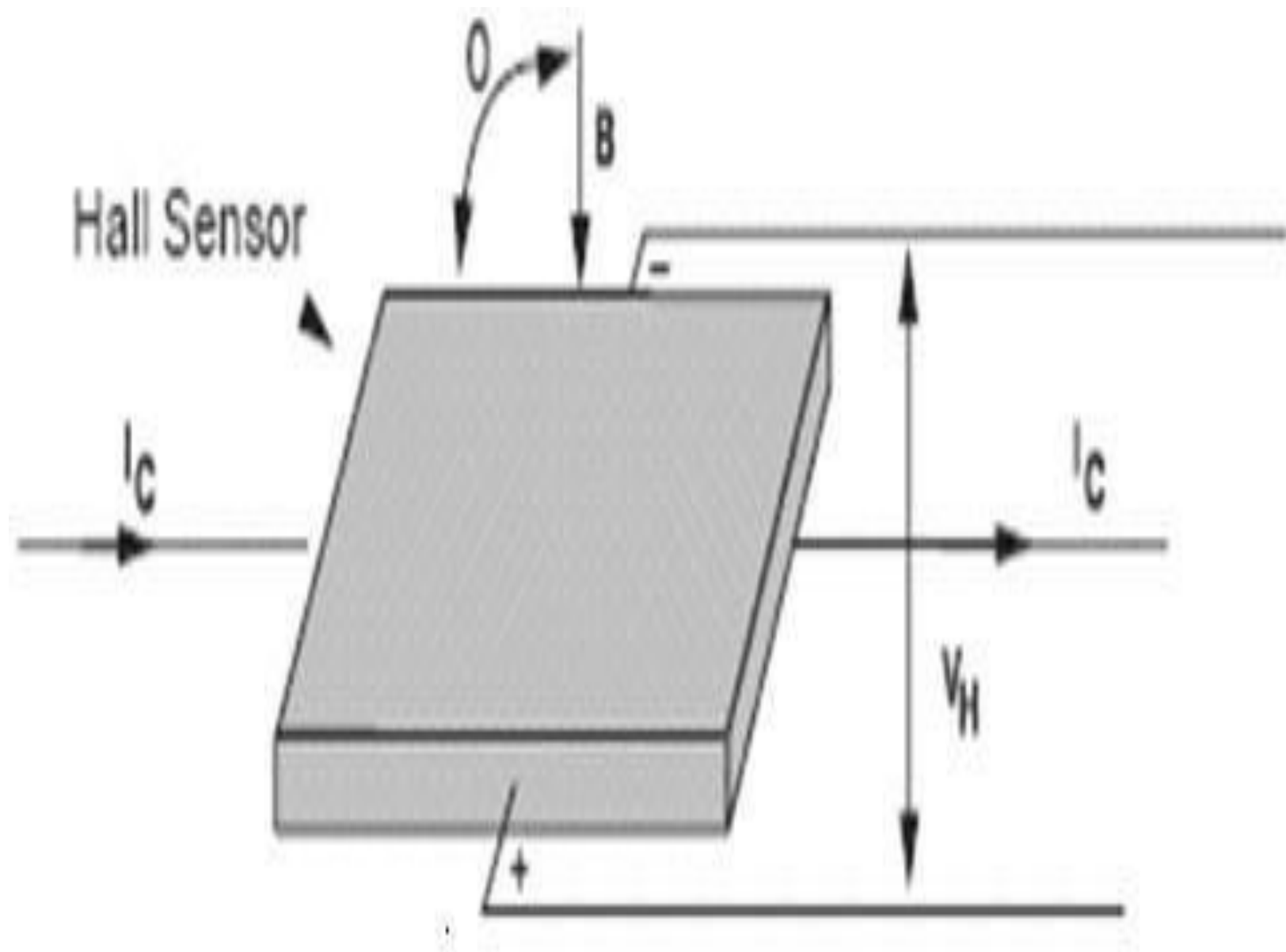

Commercially available Hall generators made of :

- Bulk Indium Arsenide (InAs)
- Thin Film InAs
- Gallium Arsenide (GaAs)
- Indium Antimonide (InSb).

RESISTANCE TEMPERATURE DETECTOR (RTD)

- Resistance temperature detector (RTD) devices are conductors used for temperature sensing.
- They can be used in bridge method as well as ohmmeter method to take the output.
- The change in resistance of material per unit change in temperature should be as large as possible.

RESISTANCE TEMPERATURE DETECTOR (RTD)

- The material should have high value of resistivity to get required value in less space.
- Resistance and temperature relation should be continuous and stable.
- Platinum, nickel and copper are the most commonly used.
- Tungsten and nickel alloy are also used.

APPLICATIONS OF RTD

- They can be used in average and differential temp. measurement.
- Differential temp. sensing to an accuracy of 0.05° have been accomplished in a nuclear reactor coolant heat rise application.

Humidity Measurement



Resistance Gyrometer

It is an active transducer.

- These instruments are suitable for measuring moisture levels between 15% and 95%.
- It has typical measurement uncertainty of 3%.
- Atmospheric contaminants and operation in saturation conditions both cause characteristics drift.

APPLICATIONS

Humidity sensors can be used not only to measure the humidity in an atmosphere but also to automatically control:

-> Humidifiers

-> Dehumidifiers

-> Air conditioners for adjustment.

Data Acquisition System

PC-based Data Acquisition System Overview

- In the last few years, industrial PC I/O interface products have become increasingly reliable, accurate and affordable. PC-based data acquisition and control systems are widely used in industrial and laboratory applications like monitoring, control, data acquisition and automated testing.
- Selecting and building a DA&C (Data Acquisition and Control) system that actually does what you want it to do requires some knowledge of electrical and computer engineering.
 - Transducers and actuators
 - Signal conditioning
 - Data acquisition and control hardware
 - Computer systems software

Data Acquisition System

Introduction I

A data acquisition system consists of many components that are integrated to:

- Sense physical variables (use of transducers)
- Condition the electrical signal to make it readable by an A/D board

Data Acquisition System

Introduction II

- Convert the signal into a digital format acceptable by a computer
- Process, analyze, store, and display the acquired data with the help of software

Data Acquisition System Block Diagram

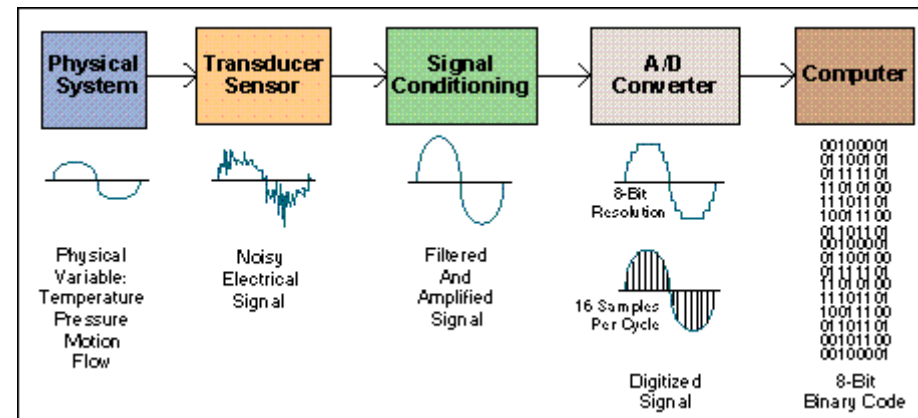

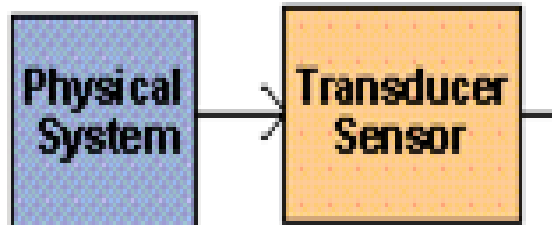

Transducers

Sense physical phenomena and translate it into electric signal.

- Temperature
- Pressure
- Light
- Force
- Displacement
- Level
- Electric signals
- ON/OFF switch

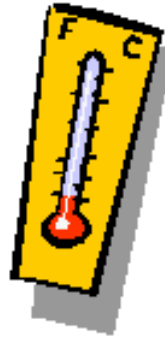

Transducers and Actuators

- A transducer converts temperature, pressure, level, length, position, etc. into voltage, current, frequency, pulses or other signals.
- An actuator is a device that activates process control equipment by using pneumatic, hydraulic or electrical power. For example, a valve actuator opens and closes a valve to control fluid rate.

Signal Conditioning

- Signal conditioning circuits improve the quality of signals generated by transducers before they are converted into digital signals by the PC's data-acquisition hardware.
- Examples of signal conditioning are signal scaling, amplification, linearization, cold-junction compensation, filtering, attenuation, excitation, common-mode rejection, and so on.

Signal Conditioning

Electrical signals are conditioned so they can be used by an analog input board. The following features may be available:

- Amplification
- Isolation
- Filtering
- Linearization

Data Acquisition

- Data acquisition and control hardware generally performs one or more of the following functions:
 - analog input,
 - analog output,
 - digital input,
 - digital output and
 - counter/timer functions.

Analog Inputs (A/D)

- Analog to digital (A/D) conversion changes analog voltage or current levels into digital information. The conversion is necessary to enable the computer to process or store the signals.

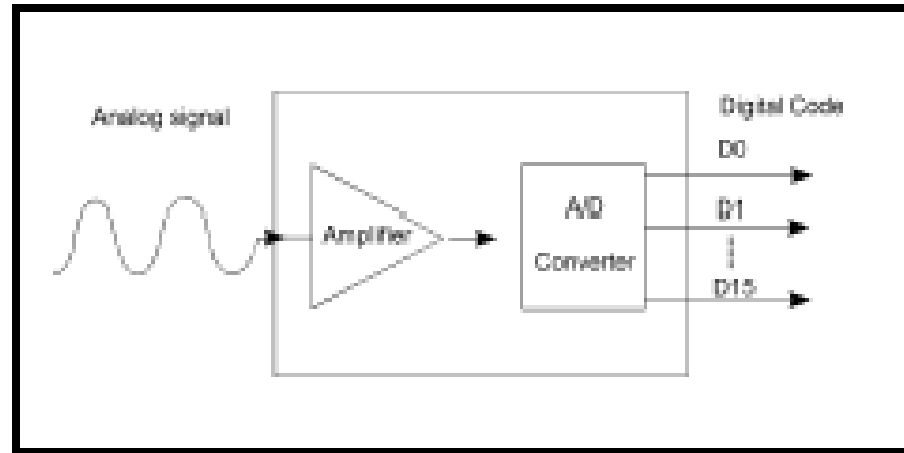

Analog Inputs (A/D)

- The most significant criteria when selecting A/D hardware are:
 - 1. Number of input channels
 - 2. Single-ended or differential input signals
 - 3. Sampling rate (in samples per second)
 - 4. Resolution (usually measured in bits of resolution)
 - 5. Input range (specified in full-scale volts)
 - 6. Noise and nonlinearity



Analog to Digital (A/D) Converter

- Input signal
- Sampling rate
- Throughput
- Resolution
- Range
- Gain



- Analog

- ✓ Signal is continuous

- Example: strain gage. Most of transducers produce analog signals

- Digital

- ✓ Signal is either ON or OFF

- Example: light switch.

A/D Converter:

Sampling Rate

- Determines how often conversions take place.
- The higher the sampling rate, the better.

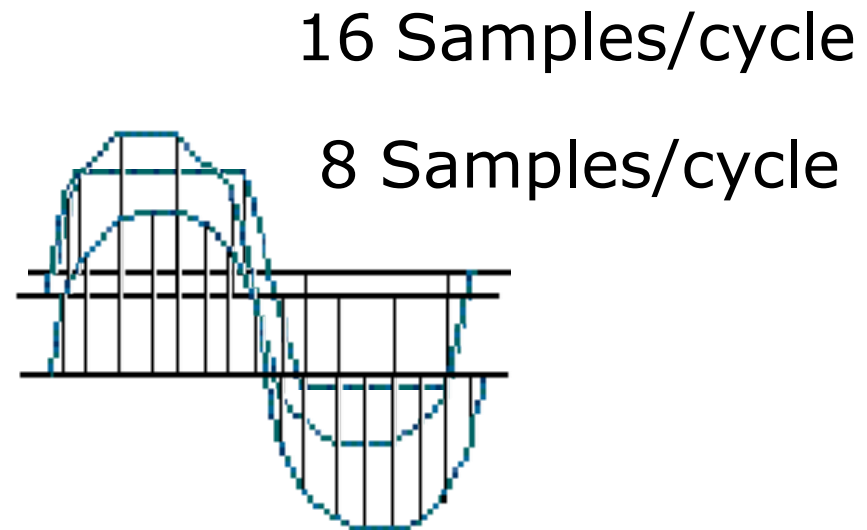
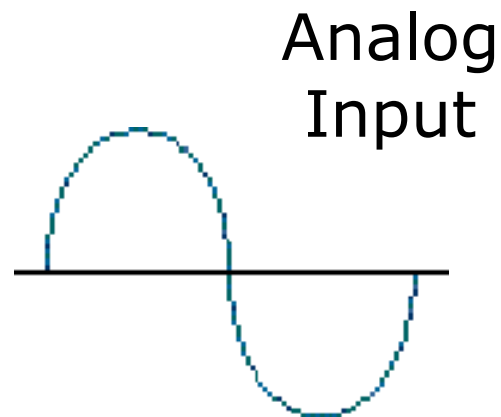
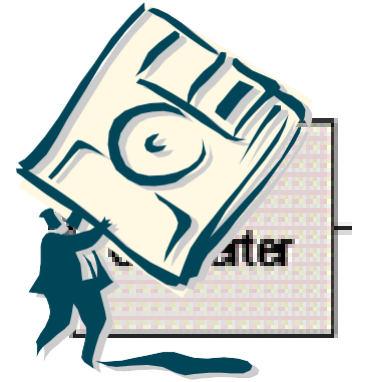

- Aliasing.

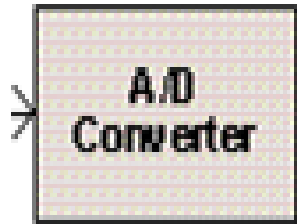

✓ Acquired signal gets distorted if sampling rate is too small.

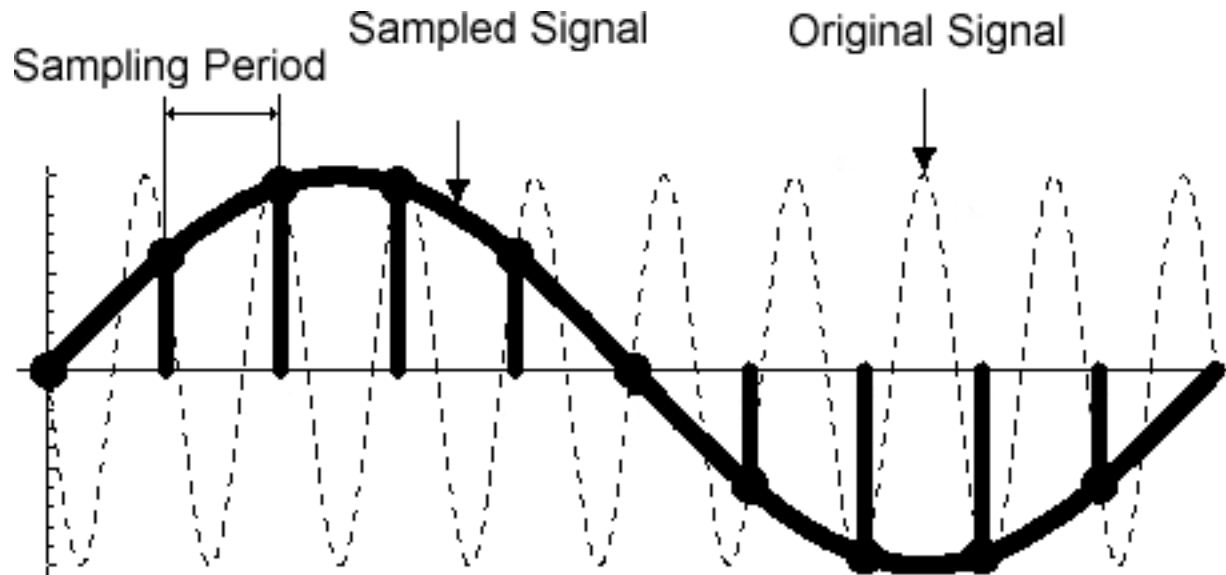

Effective rate of each individual channel is inversely proportional to the number of channels sampled.

Example:

- 100 KHz maximum.
- 16 channels.

100 KHz/16 = 6.25 KHz per channel.



A/D Converter:

Range

- Minimum and maximum voltage levels that the A/D converter can quantize



- Ranges are selectable (either hardware or software) to accurately measure the signal

A/D Converter:

Resolution

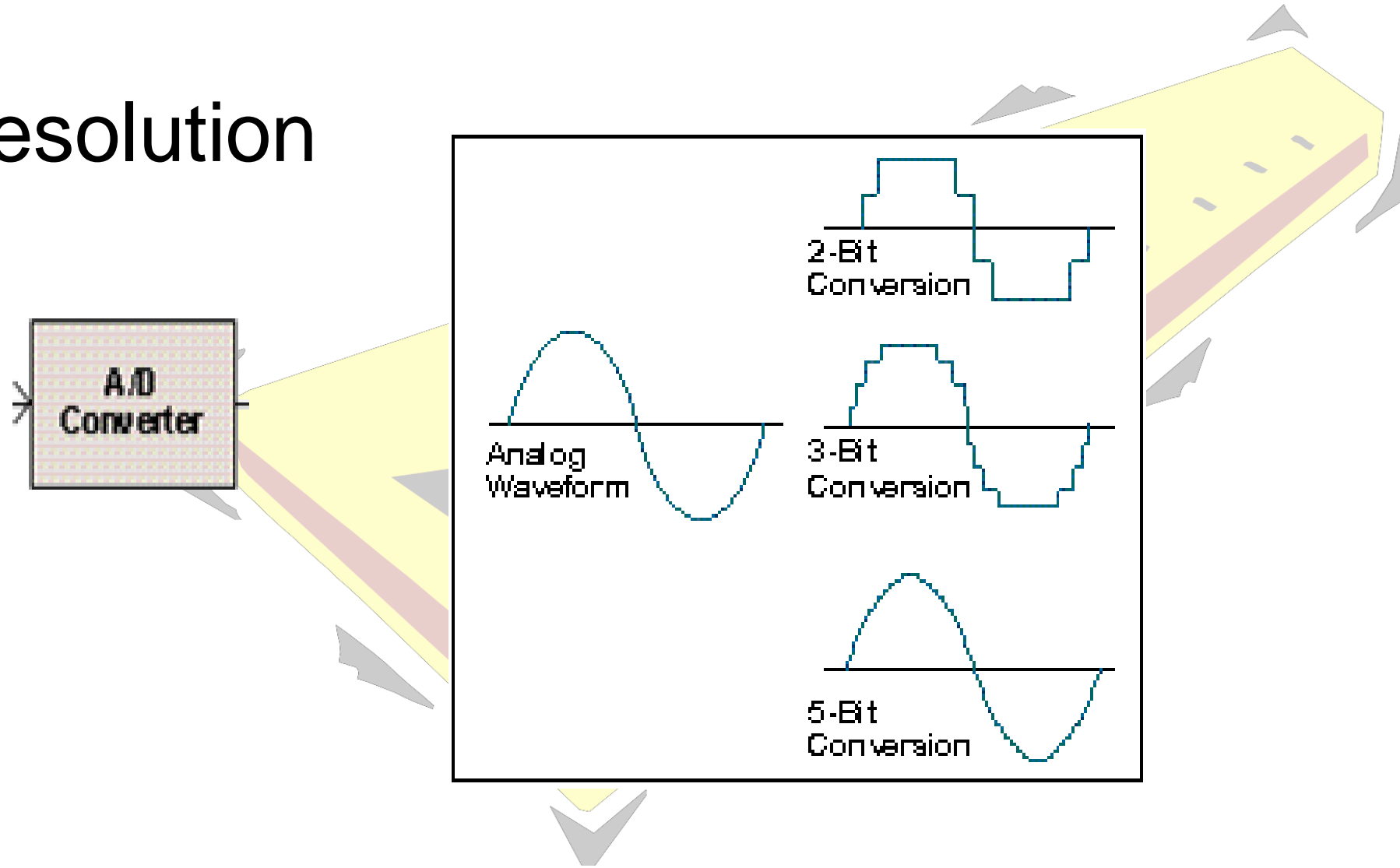

Analog Outputs (D/A)

- The opposite of analog to digital conversion is digital to analog (D/A) conversion. This operation converts digital information into analog voltage or current. D/A devices allow the computer to control real-world events.
- Analog output signals may directly control process equipment. The process can give feedback in the form of analog input signals. This is referred to as a closed loop control system with PID control.
- Analog outputs can also be used to generate waveforms. In this case, the device behaves as a function generator.

Analog Outputs (D/A)

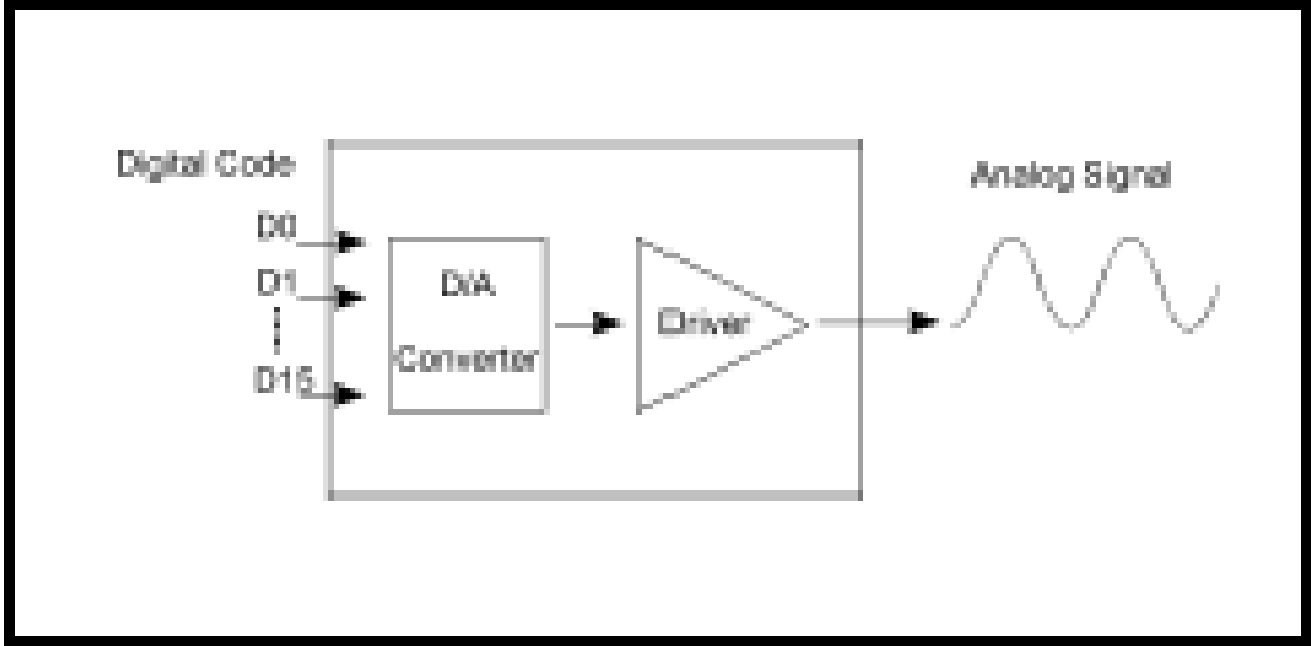



Data Acquisition Software

- It can be the most critical factor in obtaining reliable, high performance operation.
- Transforms the PC and DAQ hardware into a complete DAQ, analysis, and display system.
- Different alternatives:
 - Programmable software.
 - Data acquisition software packages.

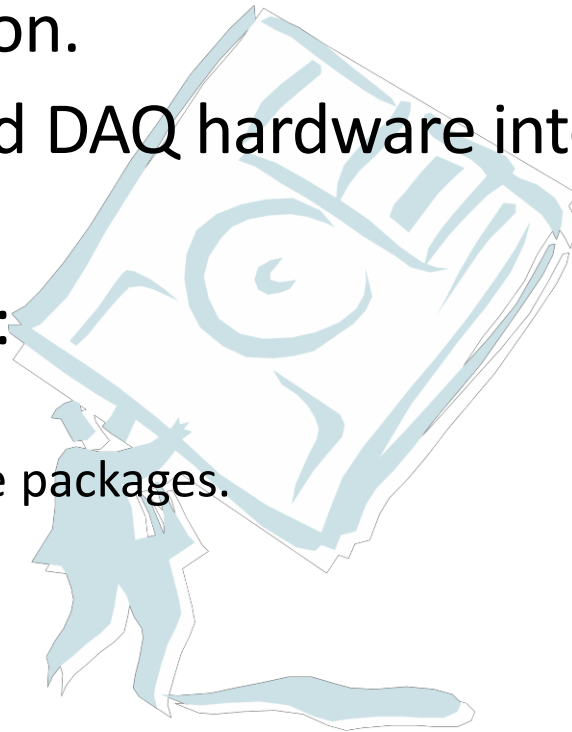



Programmable Software

- Involves the use of a programming language, such as:
 - C++, visual C++
 - BASIC, Visual Basic + Add-on tools (such as VisuaLab with VTX)
 - Fortran
 - Pascal
- ✓ Advantage: flexibility
- ✓ Disadvantages: complexity and steep learning curve





Data Acquisition Software

- Does not require programming.
- Enables developers to design the custom instrument best suited to their application.

Examples: TestPoint, SnapMaster, LabView, DADISP, DASYLAB, etc.



Designing a DAS: Factors to Consider

- Is it a fixed or a mobile application?
- Type of input/output signal: digital or analog?
- Frequency of input signal ?
- Resolution, range, and gain?
- Continuous operation?
- Compatibility between hardware and software. Are the drivers available?
- Overall price.