



# NARSIMHA REDDY ENGINEERING COLLEGE

## UGC AUTONOMOUS INSTITUTION

Maisammaguda (V), Kompally - 500100, Secunderabad, Telangana State, India

UGC - Autonomous Institute  
Accredited by NBA & NAAC with 'A' Grade  
Approved by AICTE  
Permanently affiliated to JNTUH

# DYNAMICS OF MACHINERY



## Unit-I

# GYROSCOPE

# Gyroscope

## WHAT IS A GYROSCOPE?

### DEFINITION:

- ▣ A **gyroscope** is a device for measuring or maintaining orientation, based on the principles of conservation of angular momentum.

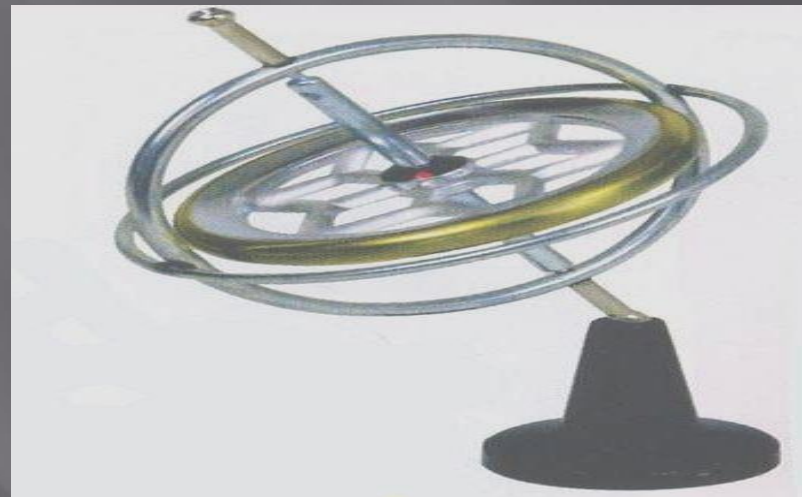

- ▣ A mechanical gyroscope is essentially a spinning wheel or disk whose axle is free to take any orientation. This orientation changes much less in response to a given external torque than it would without the large angular momentum associated with the gyroscope's high rate of spin.

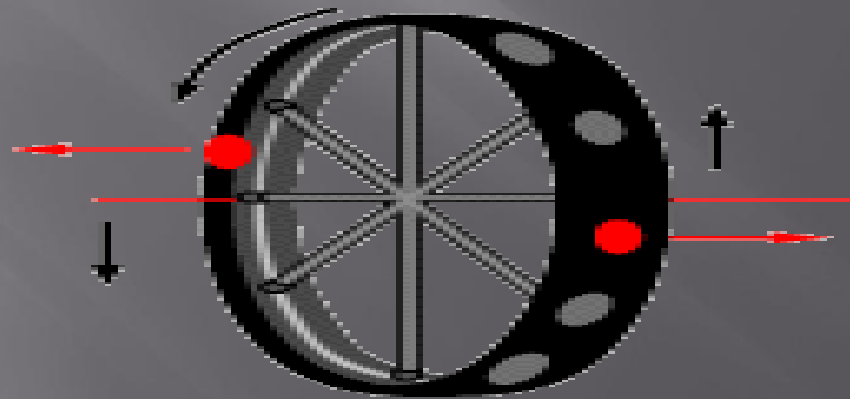

Copyright © 2000 by Pearson Education, Inc. All rights reserved.

Gyroscope  
frame

Spin axis

Gimbal

Rotor

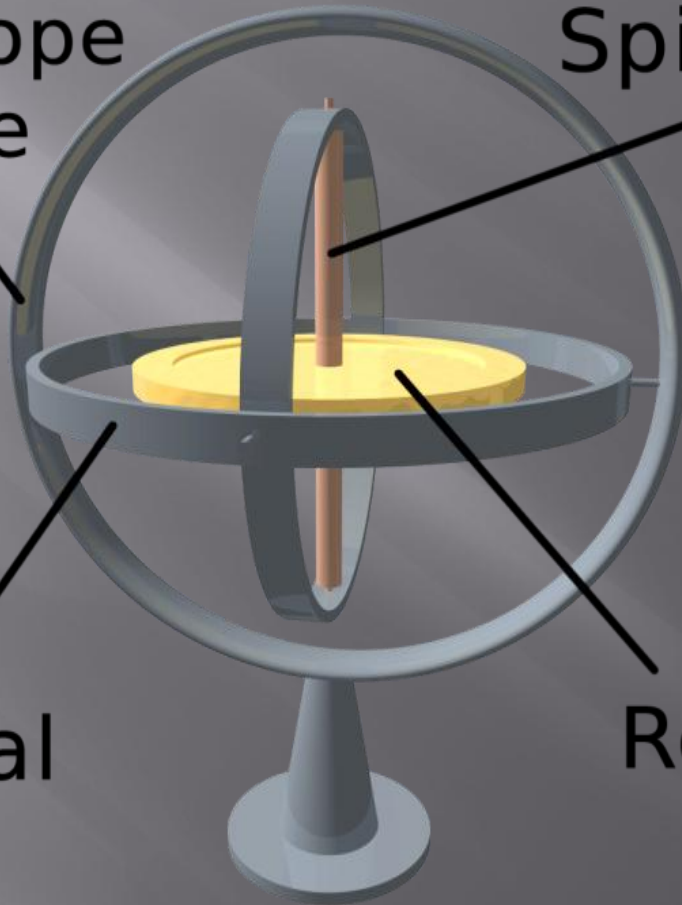

# EXAMPLES

- ▣ Gyroscopic effects are also central to things like yo-yos and Frisbees.
- ▣ Gyroscopes can be very perplexing objects because they move in peculiar ways and even seem to **defy gravity**. These special properties make gyroscopes extremely important in everything from your bicycle to the advanced navigation system on the space shuttle.

- ▣ The essence of this device is a spinning wheel on an axle. The device once spinning, tends to resist changes to its orientation due to the angular momentum of the wheel.

“Balancing the spinning bicycle wheel”

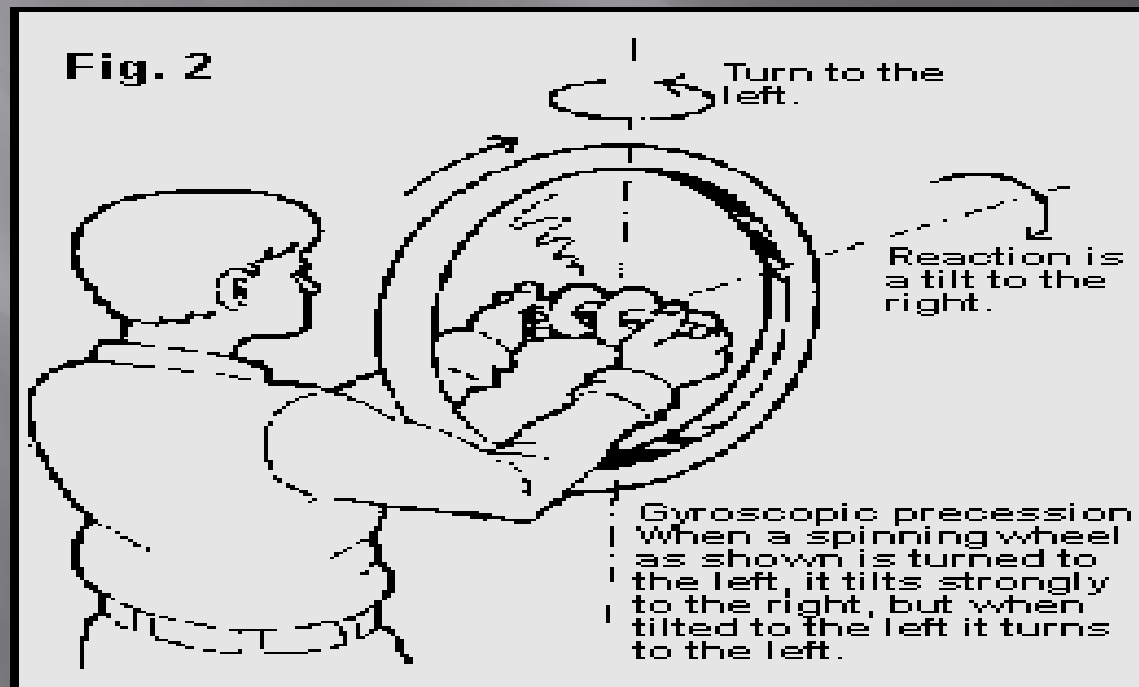

# PROPERTIES OF GYROSCOPES

Gyroscopes have two basic properties:

Rigidity and Precession

These properties are defined as follows:

1. **RIGIDITY:** The axis of rotation (spin axis) of the gyro wheel tends to remain in a fixed direction in space if no force is applied to it.
2. **PRECESSION:** The axis of rotation has a tendency to turn at a right angle to the direction of an applied force.

# PRECESSION

The fundamental equation describing the behavior of the gyroscope is:

$$\boldsymbol{\tau} = \frac{d\mathbf{L}}{dt} = \frac{d(I\boldsymbol{\omega})}{dt} = I\boldsymbol{\alpha}$$

where the vectors  $\boldsymbol{\tau}$  and  $\mathbf{L}$  are, respectively, the torque on the gyroscope and its angular momentum, the scalar  $I$  is its moment of inertia, the vector  $\boldsymbol{\omega}$  is its angular velocity, and the vector  $\boldsymbol{\alpha}$  is its angular acceleration.

It follows from this that a torque  $\boldsymbol{\tau}$  applied perpendicular to the axis of rotation, and therefore perpendicular to  $\mathbf{L}$ , results in a rotation about an axis perpendicular to both  $\boldsymbol{\tau}$  and  $\mathbf{L}$ . This motion is called **precession**. The angular velocity of precession  $\omega_P$  is given by the cross product:

$$\boldsymbol{\tau} = \omega_P \times \mathbf{L}$$

- ▣ Thus if the gyroscope's spin slows down (for example, due to friction), its angular momentum decreases and so the rate of precession increases. This continues until the device is unable to rotate fast enough to support its own weight, when it stops precessing and falls off its support, mostly because friction against precession cause another precession that goes to cause the fall.

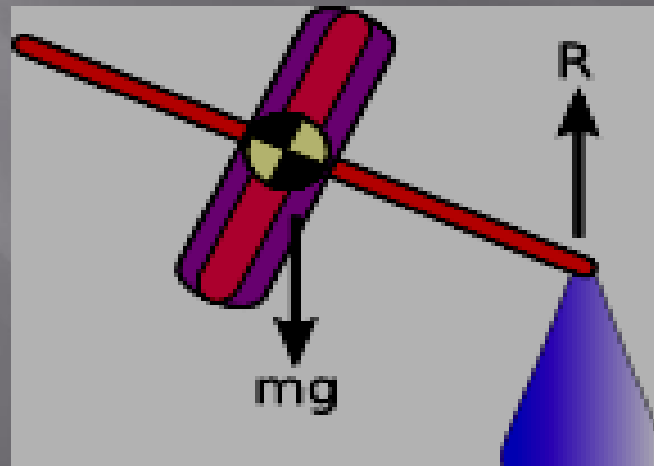

By convention, these three vectors, torque, spin, and precession, are all oriented with respect to each other according to the right-hand rule.

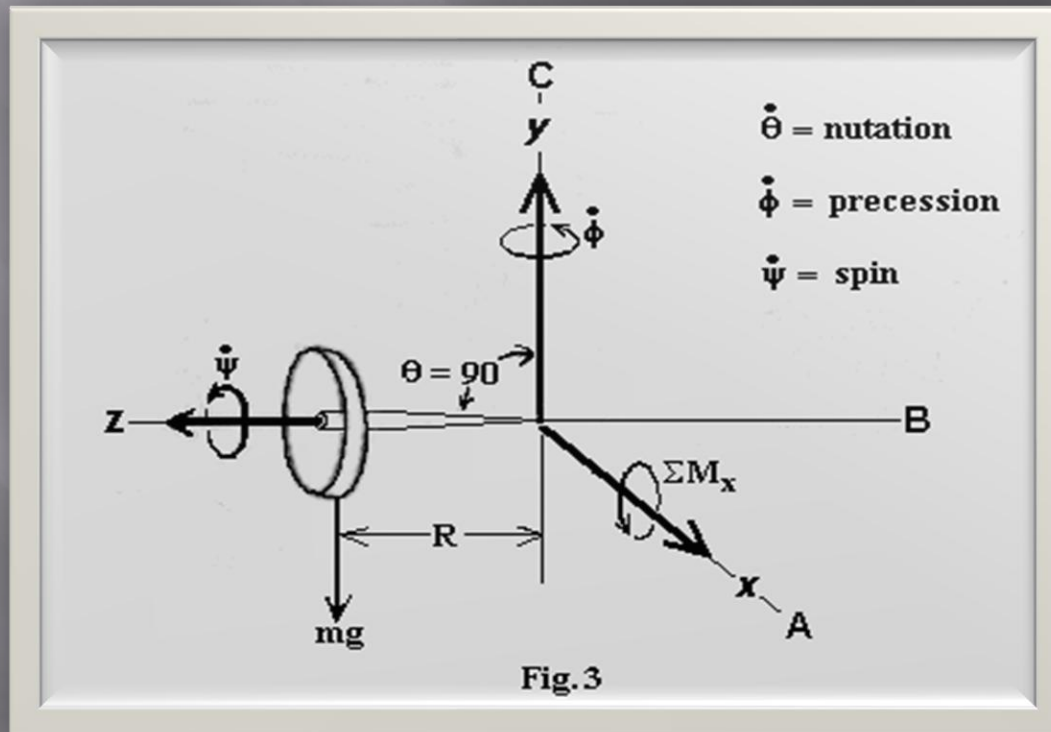

# The Cause of Precession

- Let's look at two small sections of the gyroscope as it is rotating -- the top and the bottom, like this:

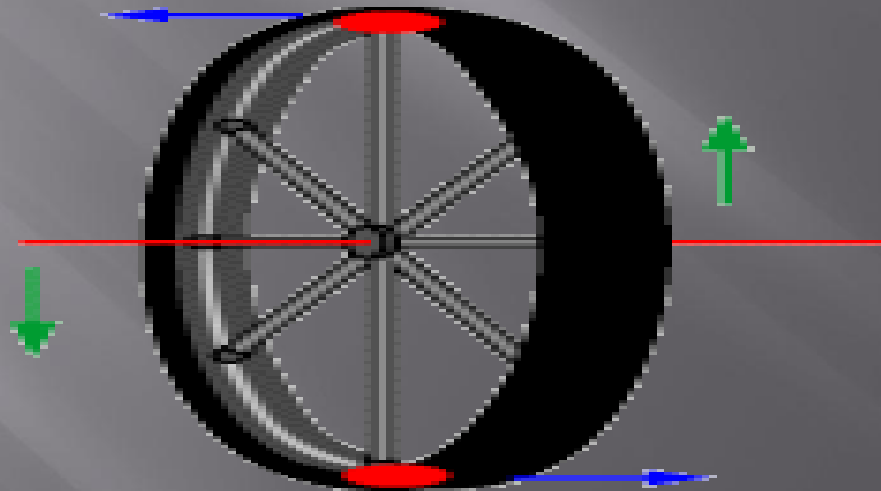

© 2000 Pearson Education, Inc. All rights reserved. This material is protected by copyright law.

- ▣ When the force is applied to the axle, the section at the top of the gyroscope will try to move to the left, and the section at the bottom of the gyroscope will try to move to the right. By Newton's first law of motion, the top point on the gyroscope is acted on by the force applied to the axle and begins to move toward the left. It continues trying to move leftward because of Newton's first law of motion, but the gyro's spinning rotates it, like this:

The gyroscope is rotating

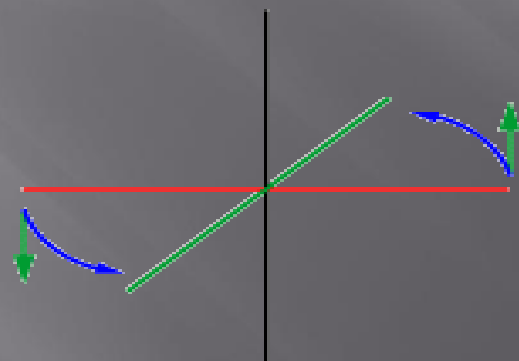
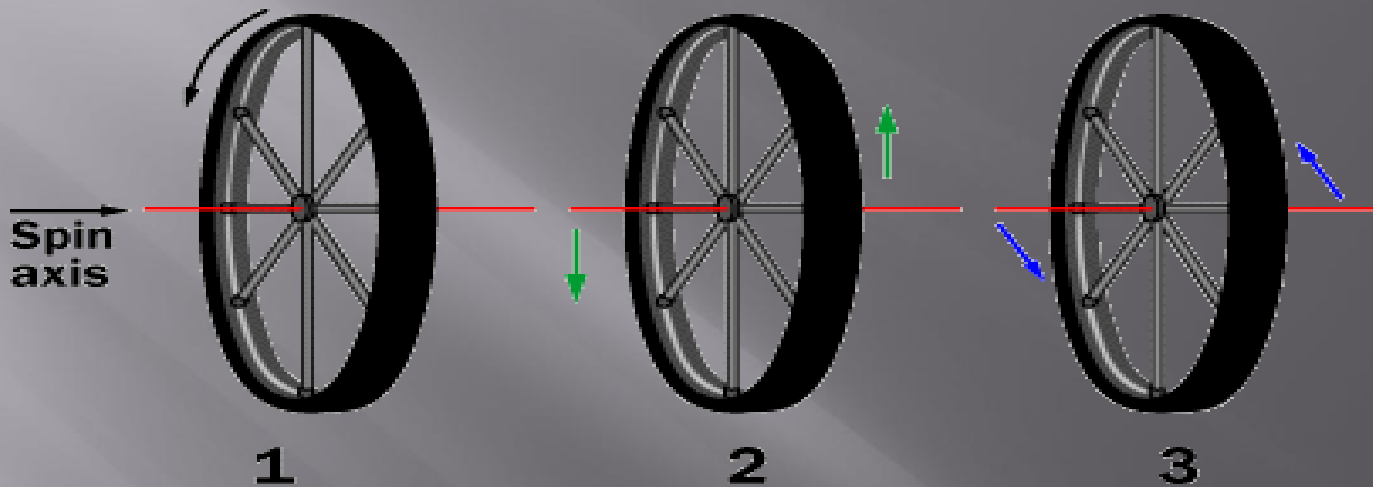

- ▣ **This effect is the cause of precession.** The different sections of the gyroscope receive forces at one point but then rotate to new positions! When the section at the top of the gyro rotates 90 degrees to the side, it continues in its desire to move to the left. These forces rotate the wheel in the precession direction. As the identified points continue to rotate 90 more degrees, their original motions are cancelled. So the gyroscope's axle hangs in the air and precesses.

# Effect of Gyroscopic Couple on Aeroplanes



When the propeller rotates in anti-clockwise direction &:

1. The aeroplane takes a right turn, the gyroscope will raise the nose and dip the tail.
2. The aeroplane takes a left turn, the gyroscope will dip the nose and raise the tail.

# Effect of Gyroscopic Couple on Naval Ship

## STEERING:

Steering is the turning of the complete ship in a curve towards left or right, while it moves forward.

## PITCHING:

Pitching is the movement of the complete ship up & down in a vertical plane.

## ROLLING:

In rolling, the axis of precession is always parallel to the axis of spin for all positions.



# STABILITY OF A FOUR WHEEL DRIVE MOVING IN A CURVED PATH

# Stability of a Four Wheel Drive Moving in a Curved Path

Consider the four wheels *A, B, C and D* of an automobile locomotive taking a turn towards left in Fig. The wheels *A and C* are inner wheels, whereas *B and D* are outer wheels. The centre of gravity (C.G.) of the vehicle lies vertically above the road surface.

- ▣ Let  $m =$  Mass of the vehicle in kg,
- ▣  $W =$  Weight of the vehicle in newtons  $= m.g,$
- ▣  $r_w =$  Radius of the wheels in metres,
- ▣  $R =$  Radius of curvature in metres
- ▣  $(R > r_w),$
- ▣  $h =$  Distance of centre of gravity, vertically
- ▣ above the road surface in metres,
- ▣  $x =$  Width of track in metres,
- ▣  $I_w =$  Mass moment of inertia of one of the
- ▣ wheels in kg-m<sup>2</sup>,
- ▣  $\omega_w =$  Angular velocity of the wheels or velocity
- ▣ of spin in rad/s,

- ▣  $I_E = \text{Mass moment of inertia of the rotating parts of the engine in kg-m}^2,$
- ▣  $\omega_E = \text{Angular velocity of the rotating parts of the engine in rad/s},$
- ▣  $G = \text{Gear ratio} = \omega_E / \omega_W,$
- ▣  $v = \text{Linear velocity of the vehicle in m/s} = \omega_W \cdot r_W$

A little consideration will show, that the weight of the vehicle ( $W$ ) *will be* equally distributed over the four wheels which will act downwards. The reaction between each wheel and the road surface of the same magnitude will act upwards.

Therefore

Road reaction over each wheel

$$= W/4 = m.g /4 \text{ newtons}$$

Let us now consider the effect of the gyroscopic couple and centrifugal couple on the vehicle



# EFFECT OF THE GYROSCOPIC COUPLE

Since the vehicle takes a turn towards left due to the precession and other rotating parts, therefore a gyroscopic couple will act.

∴ Net gyroscopic couple,

$$C = C_W \pm C_E = 4 I_W \cdot \omega_W \cdot \omega_P \pm I_E \cdot G \cdot \omega_W \cdot \omega_P$$
$$= \omega_W \cdot \omega_P (4 I_W \pm G \cdot I_e)$$

The *positive sign* is used when the wheels and rotating parts of the engine rotate in the same direction. If the rotating parts of the engine revolves in opposite direction, then *negative sign* is used.

When  $C_E > C_W$ , then  $C$  will be *-ve*. Thus the reaction will be vertically downwards on the outer wheels and vertically upwards on the inner wheels

# *Effect of the centrifugal couple*

Since the vehicle moves along a curved path, therefore centrifugal force will act outwardly at the centre of gravity of the vehicle. The effect of this centrifugal force is also to overturn the vehicle.

We know that centrifugal force,

$$F_c = (m \times v^2) / R$$

■ Total vertical reaction at each of the outer wheel

$$P_O = \frac{W}{4} + \frac{P}{2} + \frac{Q}{2}$$

And total vertical reaction at each of the inner wheel

$$R_I = \frac{W}{4} - \frac{P}{2} - \frac{Q}{2}$$

# STABILITY OF A TWO WHEEL VEHICLE TAKING A TURN

# TWO WHEEL DRIVE



Let

- ▣  $m =$  Mass of the vehicle and its rider in kg,
- ▣  $W =$  Weight of the vehicle and its rider in newtons  $= m.g$ ,
- ▣  $h =$  Height of the centre of gravity of the vehicle and rider,
- ▣  $r_w =$  Radius of the wheels,
- ▣  $R =$  Radius of track or curvature,
- ▣  $I_w =$  Mass moment of inertia of each wheel,
- ▣  $I_E =$  Mass moment of inertia of the rotating parts of the engine,
- ▣  $\omega_w =$  Angular velocity of the wheels,
- ▣  $\omega_E =$  Angular velocity of the engine,
- ▣  $G =$  Gear ratio  $= \omega_E / \omega_w$ ,
- ▣  $v =$  Linear velocity of the vehicle  $= \omega_w \times r_w$ ,
- ▣  $\theta =$  Angle of heel. It is inclination of the vehicle to the vertical for equilibrium.

# 1. Effect of gyroscopic couple

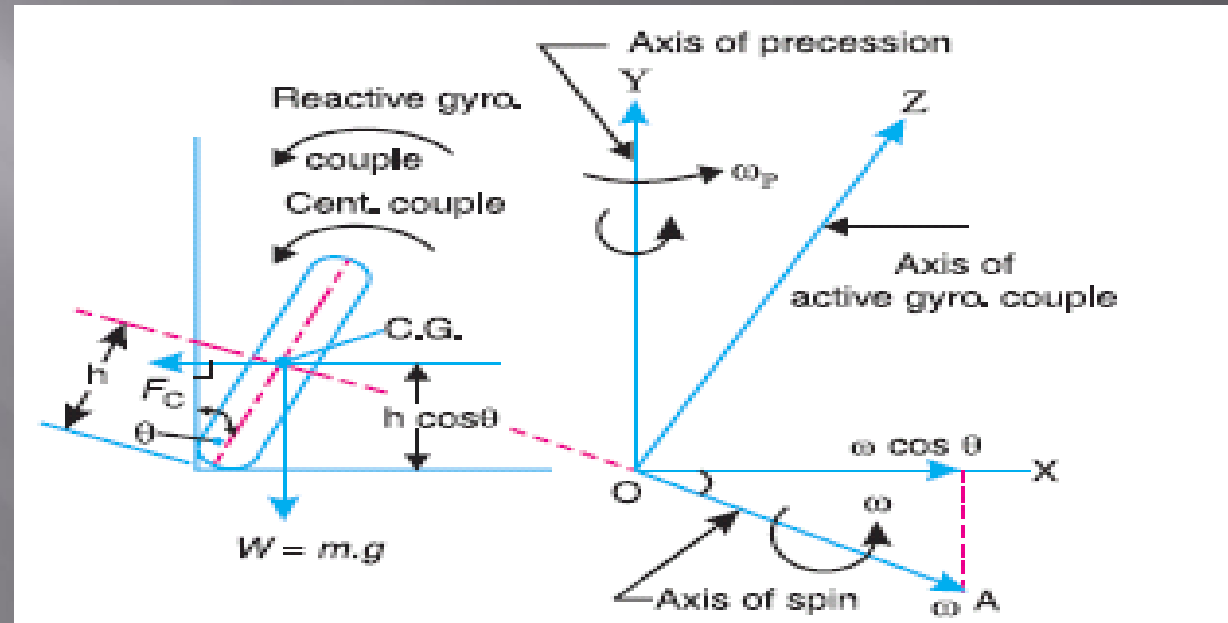
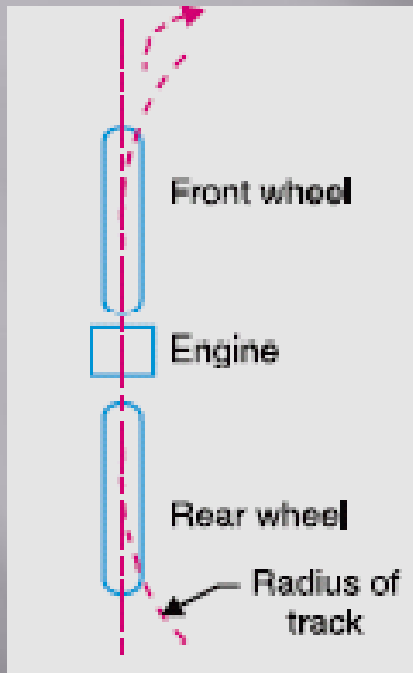

We know that

$$v = \omega_W \times r_W \quad \text{or} \quad \omega_W = v / r_W$$

And

$$\omega_E = G \cdot \omega_W = G \times \frac{v}{r_W}$$

∴ Total

$$(I \times \omega) = 2 I_W \times \omega_W \pm I_E \times \omega_E$$

$$= 2 I_W \times \frac{v}{r_W} \pm I_E \times G \times \frac{v}{r_W} = \frac{v}{r_W} (2 I_W \pm G I_E)$$

and velocity of precession,  $\omega_P = v / R$

When the wheels move over the curved path, the vehicle is always inclined at an angle  $\theta$  with the vertical plane as shown in Fig. *This angle is known as*

*angle of heel.*

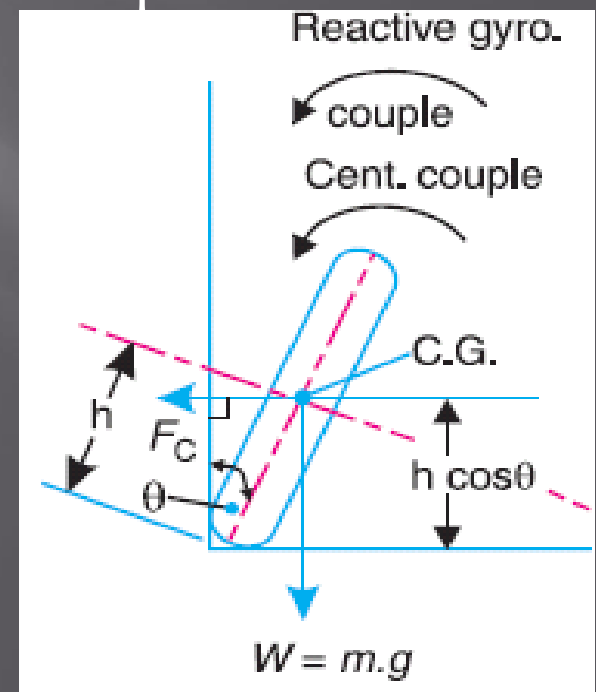

## ∴ Gyroscopic couple

$$\begin{aligned} C_1 &= I \cdot \omega \cos \theta \times \omega_P = \frac{v}{r_W} (2 I_W \pm G I_E) \cos \theta \times \frac{v}{R} \\ &= \frac{v^2}{R r_W} (2 I_W \pm G I_E) \cos \theta \end{aligned}$$

### Notes :

**(a)** When the engine is rotating in the same direction as that of wheels, then the positive sign is used in the above expression and if the engine rotates in opposite direction, then *negative sign is used*.

**(b)** The gyroscopic couple will act over the vehicle outwards i.e. in the *anticlockwise direction* when seen from the front of the vehicle. The tendency of this couple is to overturn the vehicle in outward direction.

## 2. Effect of centrifugal couple

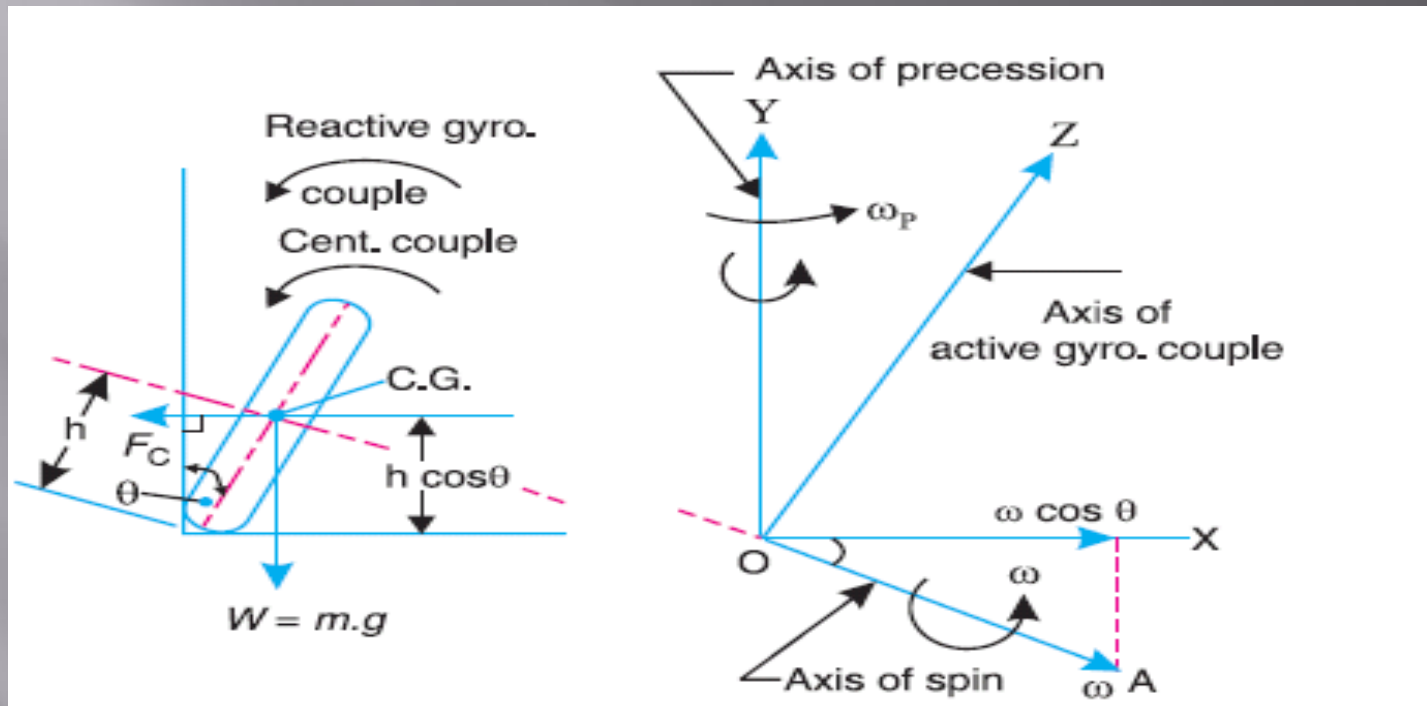

Centrifugal force ,

$$F_C = \frac{m.v^2}{R}$$

Centrifugal Couple ,

$$C_2 = F_C \times h \cos \theta = \left( \frac{m.v^2}{R} \right) h \cos \theta$$

Total overturning couple,

$C_o = \text{Gyroscopic couple} + \text{Centrifugal couple}$

$$\begin{aligned} &= \frac{v^2}{R r_W} (2 I_W + G I_E) \cos \theta + \frac{m v^2}{R} \times h \cos \theta \\ &= \frac{v^2}{R} \left[ \frac{2 I_W + G I_E}{r_W} + m.h \right] \cos \theta \end{aligned}$$

We know that balancing couple =  $m.g.h \sin \theta$

As the stability, the overturning couple must be equal to the balancing couple, i.e

$$\frac{v^2}{R} \left( \frac{2 I_W + G I_E}{r_W} + m.h \right) \cos \theta = m.g.h \sin \theta$$

From this expression, the value of the angle of heel ( $\theta$ ) may be determined.

# Example

Find the angle of inclination with respect to the vertical of a two wheeler negotiating a turn.

Given : combined mass of the vehicle with its rider 250 kg ; moment of inertia of the engine flywheel 0.3 kg-m<sup>2</sup> ; moment of inertia of each road wheel 1 kg-m<sup>2</sup> ; speed of engine flywheel 5 times that of road wheels and in the same direction ; height of centre of gravity of rider with vehicle 0.6 m ; two wheeler speed 90 km/h ; wheel radius 300 mm ; radius of turn 50 m.

# APPLICATIONS OF GYROSCOPE

# Spinnig Tops and YOYO

- ▣ Gyroscopic effects are also central to things like yo-yos and Frisbees.

# GyroCompass and Direction Finding

- ▣ A gyrocompass is similar to a gyroscope. It is a compass that finds true north by using an (electrically powered) fast-spinning wheel and friction forces in order to exploit the rotation of the Earth. Gyrocompasses are widely used on ships. They have two main advantages over magnetic compasses:
  1. They find true north, i.e., the direction of Earth's rotational axis, as opposed to magnetic north.
  2. They are far less susceptible to external magnetic fields, e.g. those created by ferrous metal in a ship's hull.

# Ship Stabilizers and anti roll devices

- ▣ Applications of gyroscopes include navigation (INS) when magnetic compasses do not work, for the stabilization of flying vehicles like Radio-controlled helicopters or UAVs.
- ▣ In an INS, sensors on the gimbals axles detect when the platform rotates. The INS uses those signals to understand the vehicle's rotations relative to the platform. If you add to the platform a set of three sensitive accelerometers, you can tell exactly where the vehicle is heading and how its motion is changing in all three directions. With this information, an airplane's autopilot can keep the plane on course, and a rocket's guidance system can insert the rocket into a desired orbit.

# AutoPilot

- ▣ A typical airplane uses gyroscopes in everything from its compass to its autopilot.
- ▣ The Russian Mir space station used 11 gyroscopes to keep its orientation to the sun, and the Hubble Space Telescope has a batch of navigational gyros as well.