

CAD/CAM 23ME506



Topic: Unit V Flexible manufacturing system

Mrs. P. Shruthi

Assistant Professor, Mechanical Engineering
Narsimha Reddy Engineering College (Autonomous)
Secunderabad, Telangana, India- 500100.



NARSIMHA REDDY ENGINEERING COLLEGE
UGC AUTONOMOUS INSTITUTION

Maisammaguda (V), Kompally - 500100, Secunderabad, Telangana State, India

UGC - Autonomous Institute
Accredited by **NBA & NAAC** with '**A**' Grade
Approved by **AICTE**
Permanently affiliated to **JNTUH**

Unit- 5

FMS, CAQC, CIM

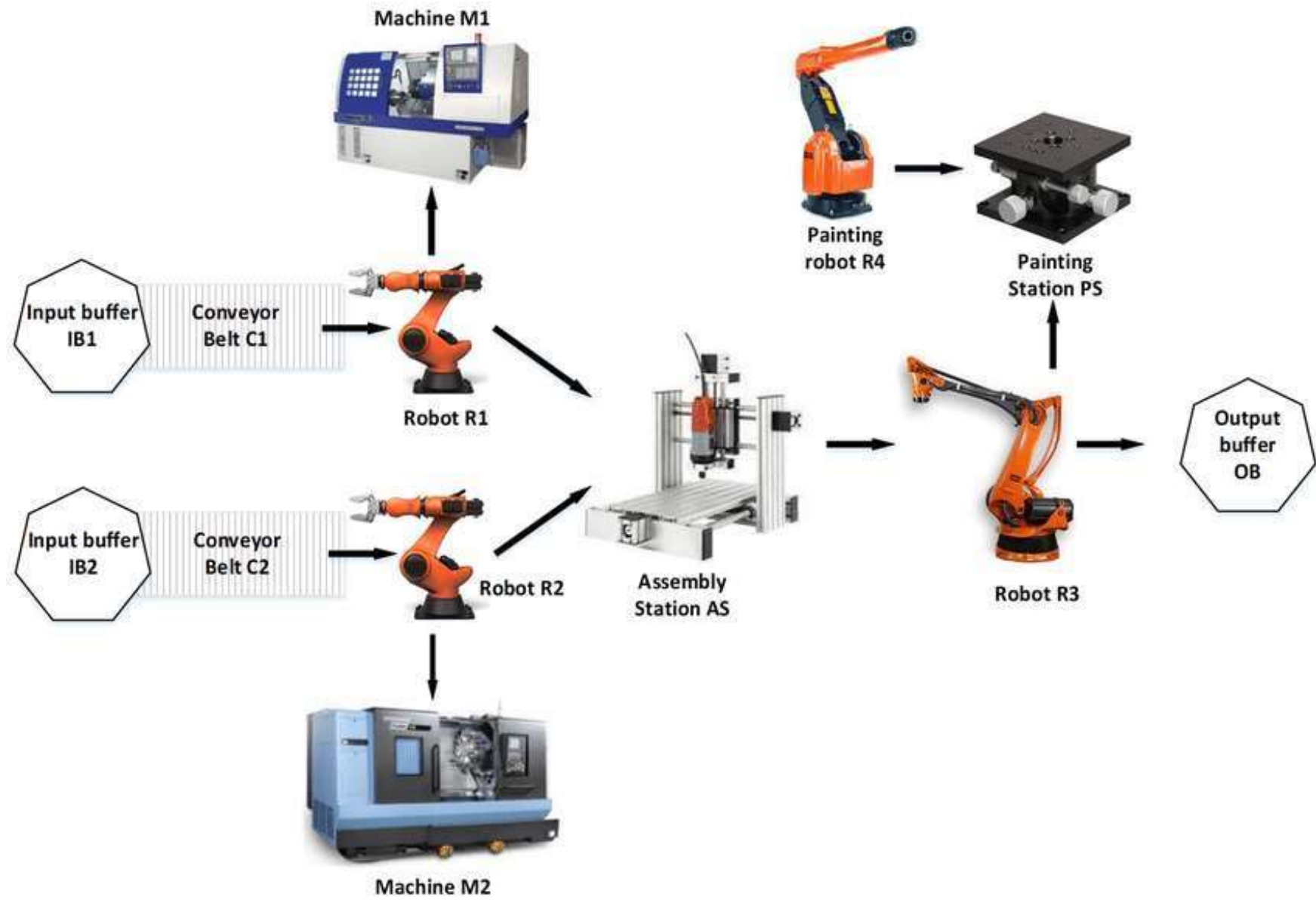

Flexible manufacturing system

The basic components of an FMS are: workstations, material handling and storage systems, computer control system, and the personnel that manage and operate the system.

The main objective of the flexible manufacturing system (FMS) is to balance the productivity of the production floor as well as maintaining its flexibility.

1. PROGRESSIVE OR LINE TYPE

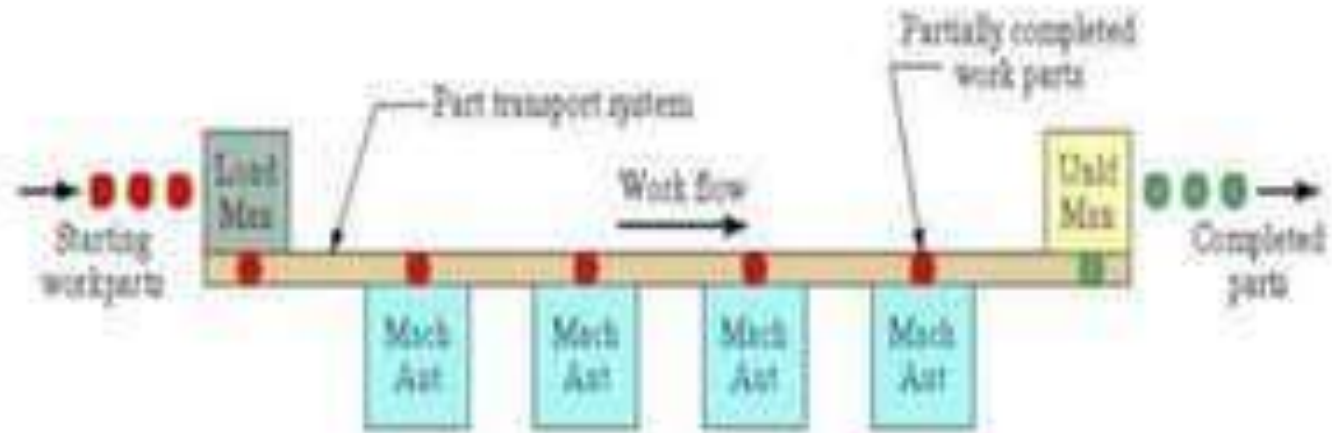

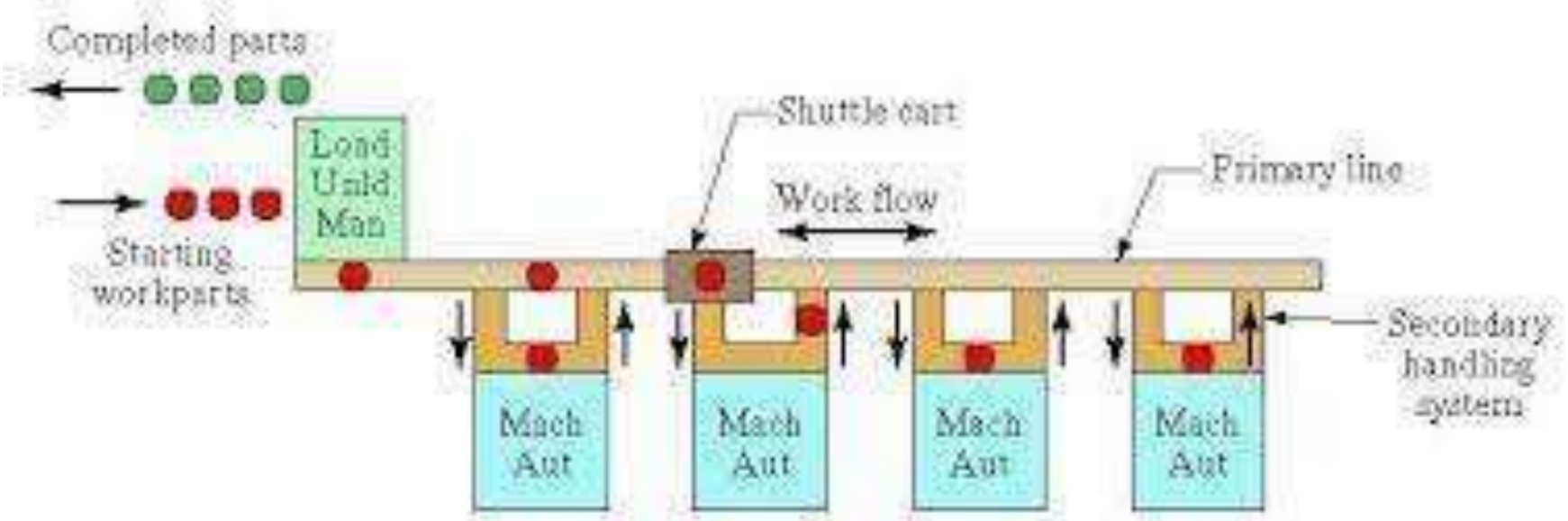

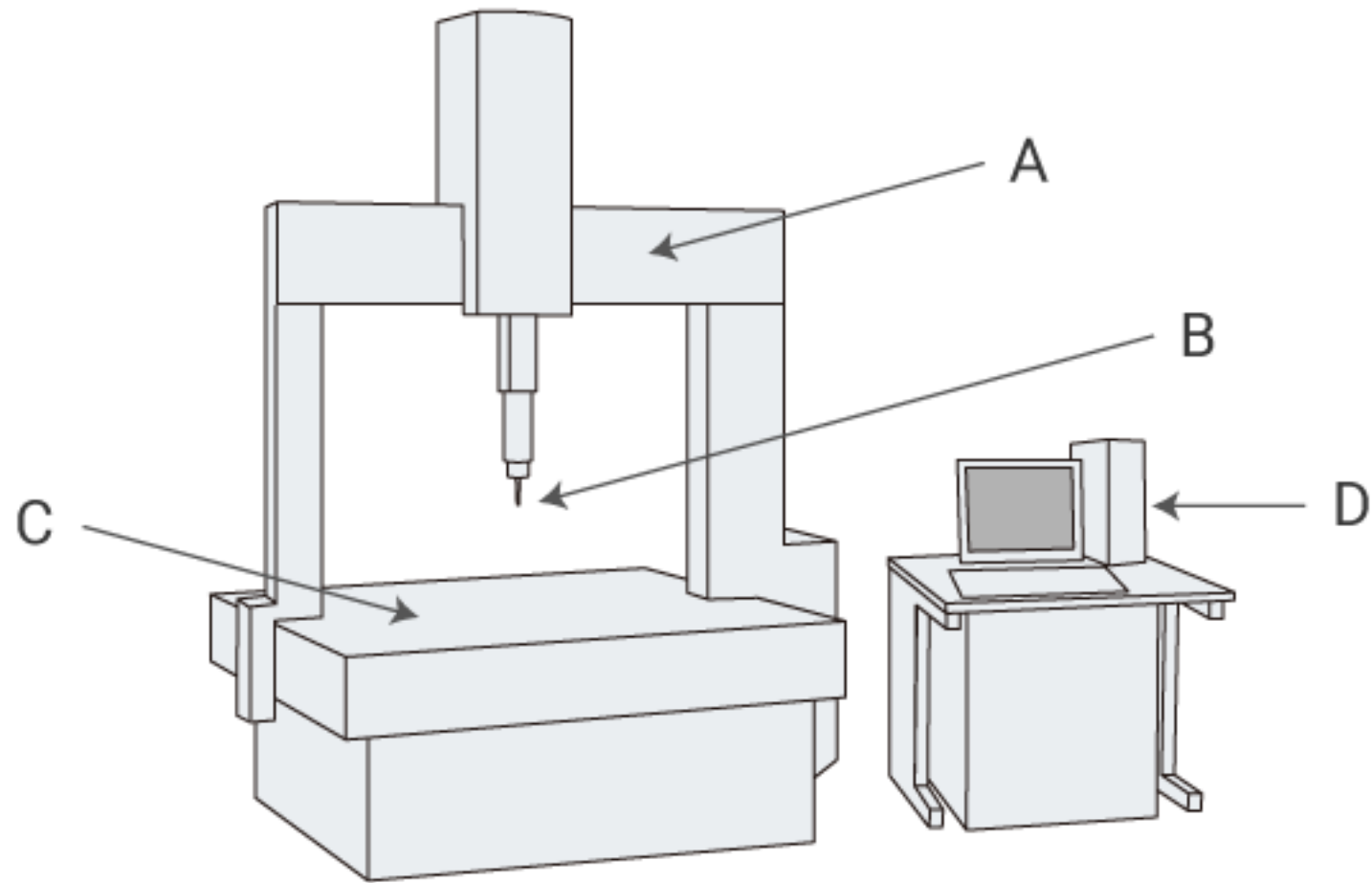

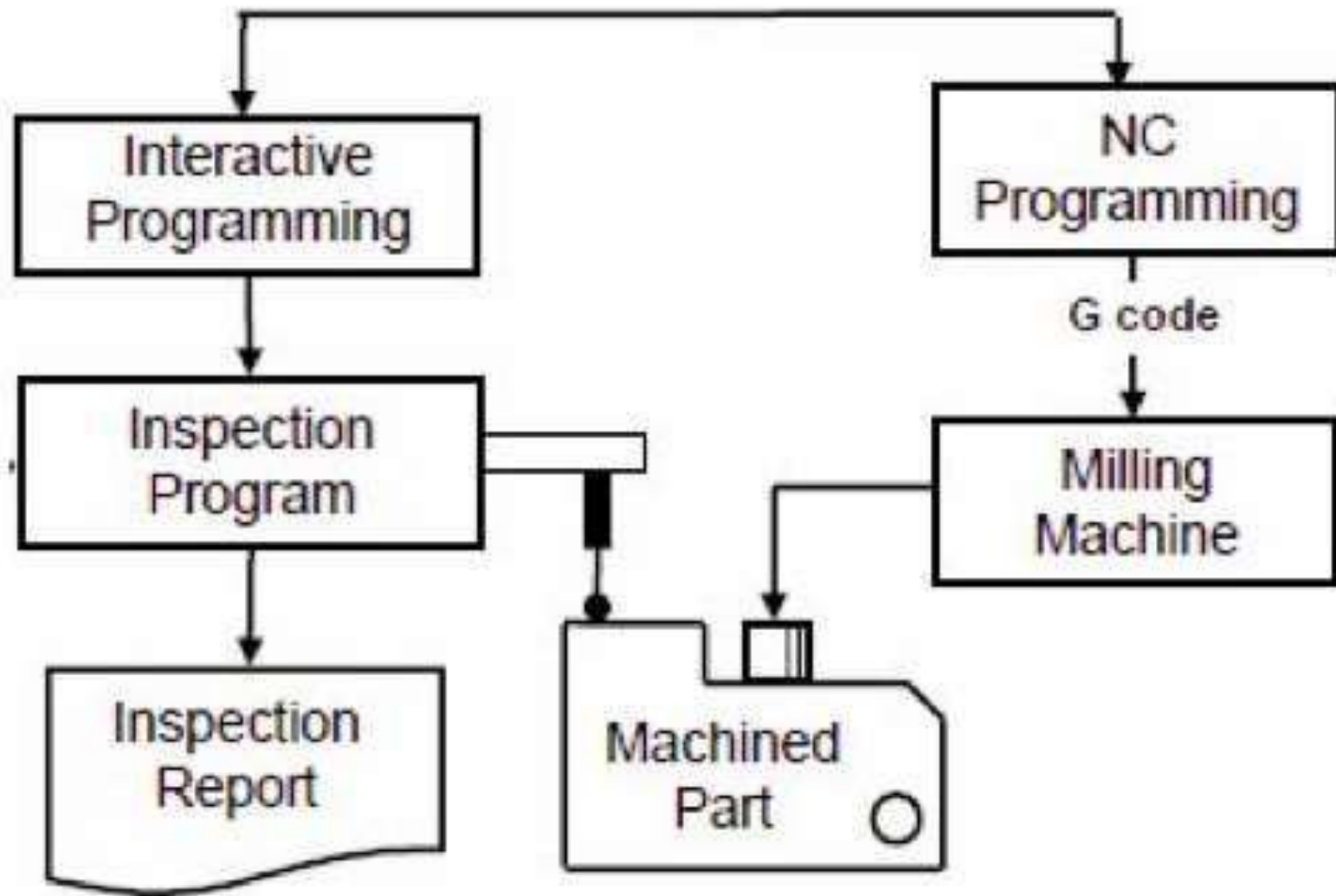

Additionally, CAQC means that a 100% inspection can be conducted on every item being manufactured without too much difficulty. In traditional quality control testing, it isn't possible to test every one of the hundreds or thousands of products being made so only a sample can be taken.

Computer-aided engineering (CAE) is the use of computer software to simulate performance in order to improve product designs or assist in the resolution of engineering problems for a wide range of industries. This includes simulation, validation and optimization of products, processes, and manufacturing tools.

Thank You..