

UNIT - III

Transmission Systems & Suspension System

Transmission Systems

It is a system by means of which power developed by the engine is transmitted to the road wheels to propel the vehicle.

Chief function of the device is to receive power at one torque and angular velocity and to deliver it at another torque and the corresponding angular velocity.

REQUIREMENTS OF TRANSMISSION SYSTEM

1. To provide for disconnecting the engine from the driving wheels.
2. When the engine is running, to enable the connection to the driving wheels to be made smoothly and without shock.
3. To enable the leverage between the engine and driving wheels to be varied.
4. It must reduce the drive-line speed from that of the engine to that of the driving wheels in a ratio of somewhere between about 3:1 and 10:1 or more, according to the relative size of engine and weight of vehicle.
5. Turn the drive, if necessary, through 90° or perhaps otherwise re-align it.
6. Enable the driving wheels to rotate at different speeds.

Manual Transmission:

The first transmission invented was the manual transmission system. The driver needs to disengage the clutch to disconnect the power from the engine first, select the target gear, and engage the clutch again to perform the gear change. This will challenge a new driver. It always takes time for a new driver to get used to this skill.

AUTOMOBILE ENGINEERING (23ME704)

Automatic Transmission:

An automatic transmission uses a fluid-coupling torque converter to replace the clutch to avoid engaging/disengaging clutch during gear change. A completed gear set, called planetary gears, is used to perform gear ratio change instead of selecting gear manually. A driver no longer needs to worry about gear selection during driving. It makes driving a car much easier, especially for a disabled or new driver. However, the indirect gear contact of the torque converter causes power loss during power transmission, and the complicated planetary gear structure makes the transmission heavy and easily broken.

Semi-Automatic Transmission:

A semi-automatic transmission tries to combine the advantages of the manual and automatic transmission systems, but avoid their disadvantages. However, the complicated design of the semi- automatic

Continuously Variable Transmission (C.V.T.):-

The Continuously Variable Transmission (C.V.T.) is a transmission in which the ratio of the rotational speeds of two shafts, as the input shaft and output shaft of a vehicle or other machine, can be varied continuously within a given range, providing an infinite number of possible ratios. The

other mechanical transmissions described above only allow a few different gear ratios to be selected

Components of manual transmission

The main components of manual transmission are:

- Clutch
- Gear box
- Slip joint

AUTOMOBILE ENGINEERING (23ME704)

- Universal joint
- Propeller shaft
- Final drive
- Differential unit
- Rear axle

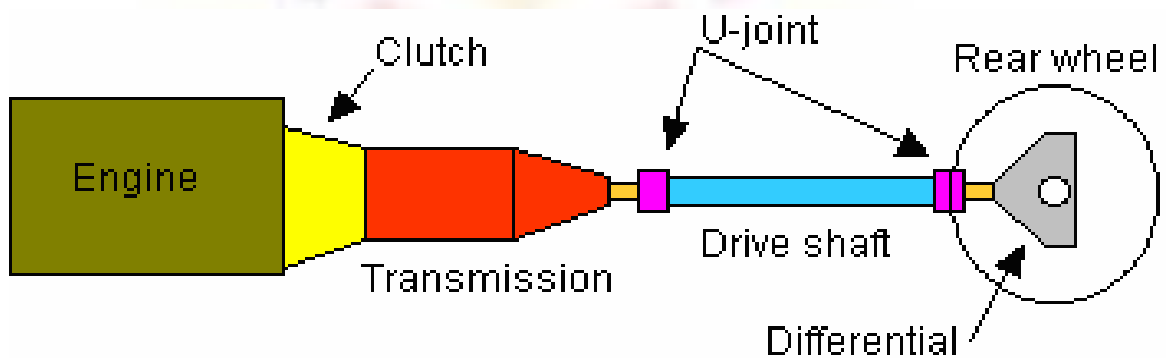

Clutch;

Clutch is a device which is used in the transmission system of automobile to engage and disengage the engine to the transmission or gear box. It is located between the transmission and the engine. When the clutch is engaged, the power flows from the engine to the rear wheels in a rear-wheel-drive transmission and the vehicle moves. When the clutch is disengaged, the power is not transmitted from the engine to the rear wheels and vehicle stops even if engine is running.

The friction depends upon the surface area contact. The friction surfaces are so designed that the driven member initially slips on driving member when initially pressure is applied. As pressure increases the driven member is brought gradually to speed the driving member.

The three main parts of clutch are:

- Driving member

AUTOMOBILE ENGINEERING (23ME704)

- Driven member

- Operating member

The driving member consists of a flywheel mounted on the engine crank shaft. The flywheel is bolted to cover which carries a pressure plate or driving disc, pressure springs and releasing levers. Thus the entire assembly of flywheel and cover rotates all the times. The clutch housing and the cover provided with openings dissipate the heat generated by friction during the clutch operation.

The driving member consists of a disc or plate called clutch plate. It is free to slide length wise on the splines of the clutch shaft. It carries friction materials on both of its surfaces when it is gripped

The operating members consists of a foot pedal, linkage, release or throw-out bearing, release levers and springs necessary to ensure the proper operation of the clutch.

Now the driving member in an automobile is flywheel mounted on crank shaft, the driven member is the pressure plate mounted on transmission or gear box input shaft. Friction surfaces or clutch plates is placed between two members.

Types of Friction Materials:

The friction materials of the clutch plate are generally of 3 types:

- Mill Board Type

- Molded type

- Woven type

AUTOMOBILE ENGINEERING (23ME704)

Mill Board type friction materials mainly include asbestos material with different types of impregnates.

Molded type friction materials are made from a matrix of asbestos fiber and starch or any other suitable binding materials. They are then heated to a certain temperature for moulding in dies under pressure. They are also made into sheets by rolling, pressing and backs till they are extremely hard and dense. Metallic wires are used sometimes to increase wear properties.

Woven types facing materials are made by impregnating a cloth with certain binders or by weaving threads of copper or brass wires covered with long fiber asbestos and cotton. The woven sheets treated with binding solution are baked and rolled.

Table: Coefficients of Riction for Clutch Facing Materials

Sl. No.	Material	Coeffieicent Of Material(μ)
1.	Leather	0.27
2.	Cork	0.37
3.	Cotton fabric	0.4-0.5
4.	Asbestos BaseMaterials	0.35-0.4

Properties of Good Clutching:

- Good Wearing Properties
- High Resistance to heat

AUTOMOBILE ENGINEERING (23ME704)

- High coefficient of friction
- Good Binders in it

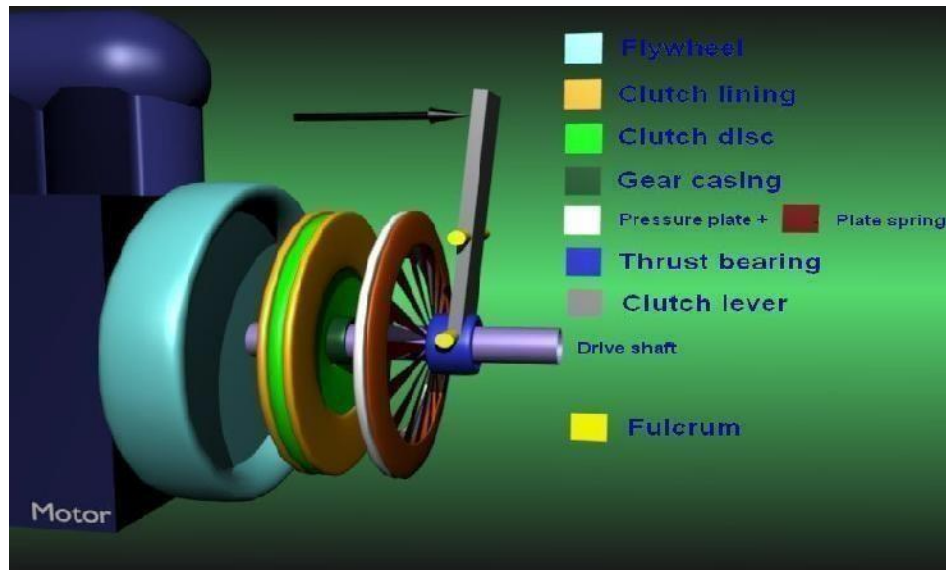

Fig: Exploded view of clutch

Single Clutch Plate:

It is the most common type of clutch plate used in motor vehicles. Basically it consists of only one clutch plate, mounted on the splines of the clutch shaft. The flywheel is mounted on engine crankshaft and rotates with it. The pressure plate is bolted to the flywheel through clutch springs, and is free to slide on the clutch shaft when the clutch pedal is operated. When the clutch is engaged the clutch plate is gripped between the flywheel and pressure plate. The friction linings are on both the sides of the clutch plate. Due to the friction between the flywheel, clutch plate and the pressure plate the clutch plate revolves the flywheel. As the clutch plate revolves the clutch shaft also

AUTOMOBILE ENGINEERING (23ME704)

. Multi-plate Clutch:

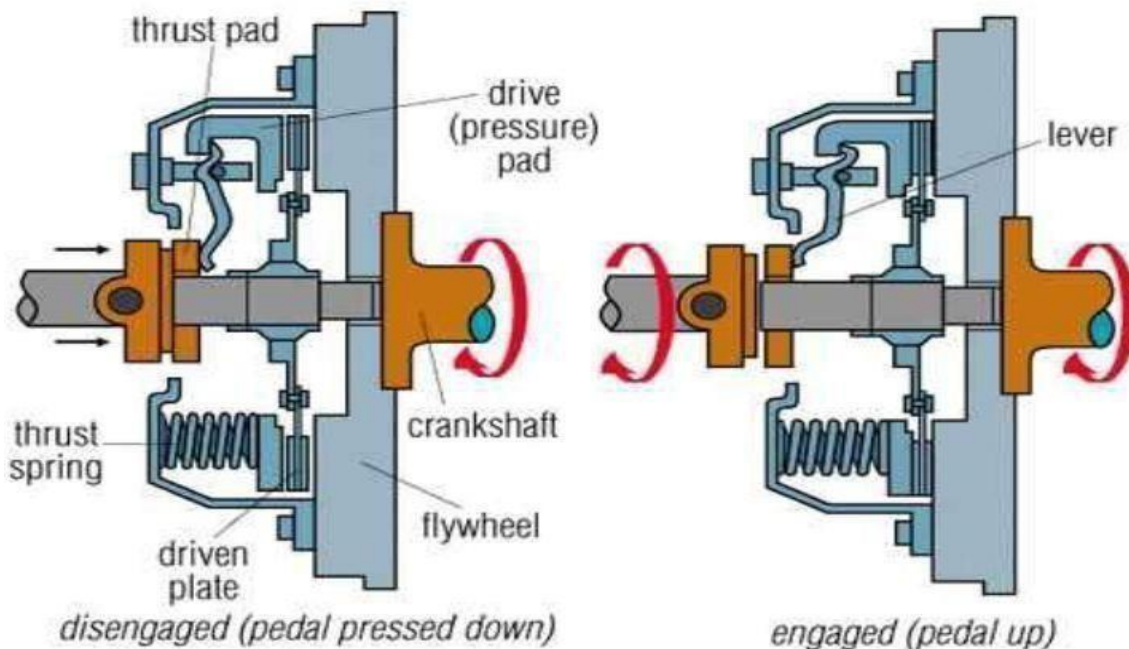

Fig: Clutch in Engaged & Disengaged Position

Multi-plate clutch consists of a number of clutch plates instead of only one clutch plate as in case of single plate clutch. As the number of clutch plates are increased, the friction surfaces also increase. The increased number of friction surfaces obviously increases the capacity of the clutch to transmit torque.

The plates are alternately fitted to engine and gear box shaft. They are firmly pressed by strong coil springs and assembled in a drum. Each of the alternate plates slides on the grooves on the flywheel and the other slides on splines on the pressure plate. Thus, each alternate plate has inner and outer splines.

The multi-plate clutch works in the same way as a single plate clutch by operating the clutch pedal. The multi-plate clutches are used in heavy commercial vehicles, racing cars and motor cycles for transmitting high torque. The multi-plate clutch may be dry or wet. When the clutch is operated

AUTOMOBILE ENGINEERING (23ME704)

in an oil bath, it is called a wet clutch. When the clutch is operated dry it is called dry clutch. The wet clutch is used in conjunction with or part of the automatic transmission.

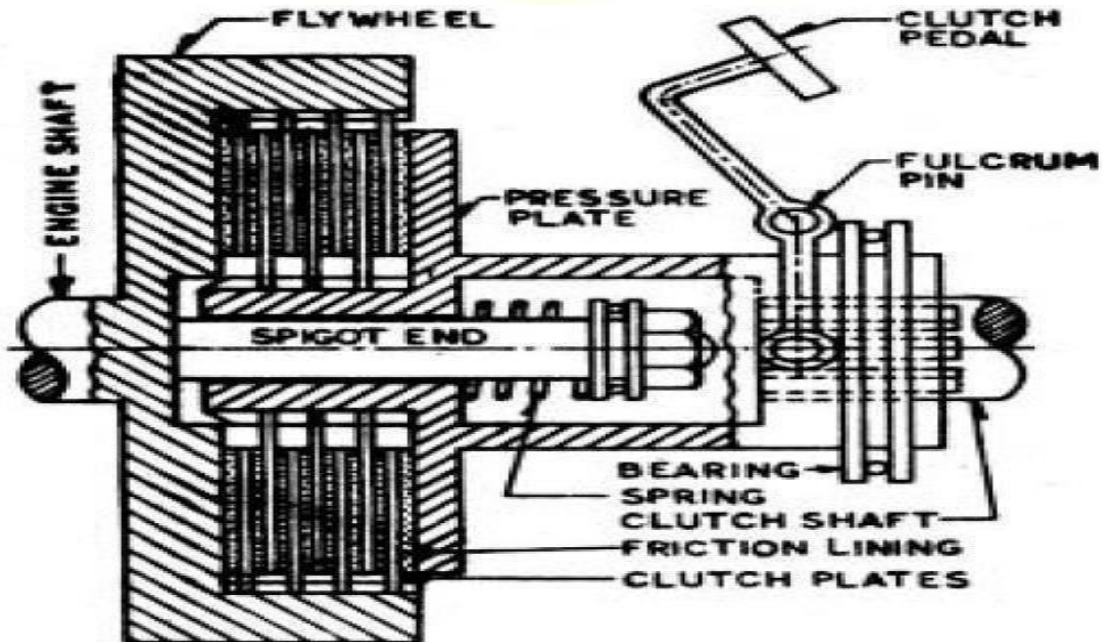

Fig : Multi-Plate Clutch

Cone Clutch:

Cone clutch consists of friction surfaces in the form of cone. The engine shaft consists of female cone. The male cone is mounted on the splined clutch shaft. It has friction surfaces on the conical portion. The male cone can slide on the clutch shaft. When the clutch is engaged the friction surfaces of the male cone are in contact with that of the female cone due to force of the spring. When the clutch pedal is pressed, the male cone slides against the spring force and the clutch is disengaged.

The only advantage of the cone clutch is that the normal force acting on the friction surfaces is greater than the axial force, as compared to the single

AUTOMOBILE ENGINEERING (23ME704)

plate clutch in which the normal force acting on the friction surfaces is equal to the axial force. The disadvantage in cone clutch is that if the angle of the cone is made smaller than 20° the male cone tends to bind in the female cone and it becomes difficult to disengage the clutch. Cone clutches are generally now only used in low peripheral speed applications although they were once common in automobiles and other combustion engine transmissions. They are usually now confined to very specialist transmissions in racing, rallying, or in extreme off-road vehicles, although they are common in power boats. Small cone clutches are used in synchronizer mechanisms in manual transmissions.

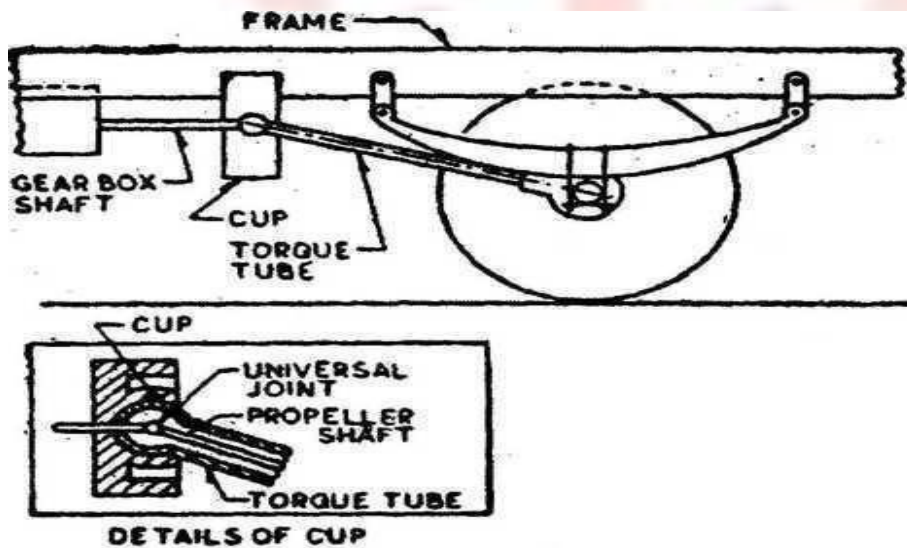

AUTOMOBILE ENGINEERING (23ME704)

Suspension System

Suspension system is the term given to the system of springs, shock absorbers and linkages that connects a vehicle to its wheels . It is basically cushion for passengers protects the luggage or any cargo and also itself from damage and wear.

Sir **William Brush** is the father of suspension system in automobiles.

The main role of suspension system are as follows:

- It supports the weight of vehicle .
- Provides smoother ride for the driver and passengers i.e. acts as cushion.
- Protects your vehicle from damage and wear .
- It also plays a critical role in maintaining self driving conditions.
- It also keeps the wheels pressed firmly to the ground for traction .
- It isolates the body from road shocks and vibrations which would otherwise be transferred to the passengers and load.
- Principle :

When a tire hits an obstruction, there is a reaction force. The size of this reaction force depends on the unsprung mass at each wheel assembly.

In general, the larger the ratio of sprung weight to unsprung weight, the less the body and vehicle occupants are affected by bumps, dips, and other surface imperfections such as small bridges. A large sprung weight to unsprung

AUTOMOBILE ENGINEERING (23ME704)

weight ratio can also impact vehicle control.

No road is perfectly flat i.e. without irregularities. Even a freshly paved highways have subtleimperfections that can be interact with vehicle's wheels.

These are the imperfections that apply forces on wheels.

According to **Newton 's law of motion** all forces have both magnitude and direction. A bump in the road causes the wheel to move up and down perpendicular to the road surface. The magnitude of

course ,depends on whether the wheel is striking a giant bump or a tiny speck. Thus, either the wheelexperiences a vertical acceleration as it passes over an imperfection.

The suspension of a car is actually part of the chassis, which comprises all of the important systemslocated beneath the car's body. These system include :

- Frame
- Suspension system
- Steering system
- Tires or Wheels

There are three fundamental components of any suspension system.

- Springs
 - Coil spring
 - Leaf springs
 - Air springs
- Dampers
 - Shock Absorbers
 - Struts:-

AUTOMOBILE ENGINEERING (23ME704)

➤ Anti-sway Bars

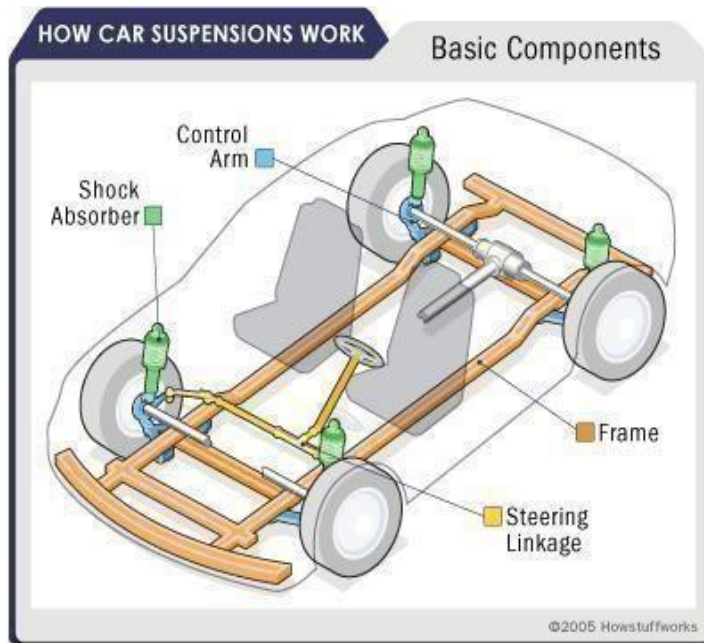

Components of Suspension system;

Types of Suspension system;

Advantages;

- Comfort to passengers
- Good handling
- Shields the vehicle from damage
- Increases life of vehicle
- Keeps the tires pressed firmly to ground.