

COURSE CONTENT

SUBJECT: DESIGN OF MACHINE ELEMENT

UNIT-I

FACULTY: SWESHAREEFA MAHAKUL

ASST. PROF. ME DEPT

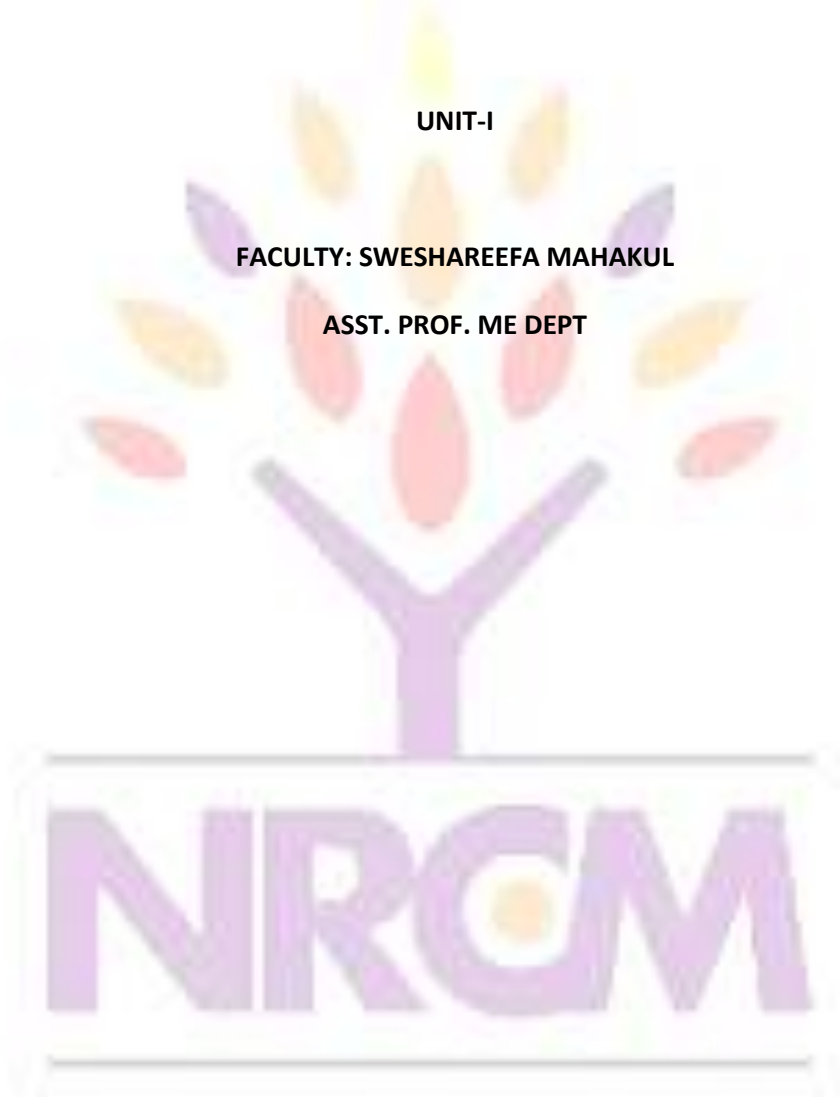

your roots to success...

Introduction

The subject Machine Design is the creation of new and better machines and improving the existing ones. A new or better machine is one which is more economical in the overall cost of production and operation. The process of design is a long and time consuming one. From the study of existing ideas, a new idea has to be conceived. The idea is then studied keeping in mind its commercial success and given shape and form in the form of drawings. In the preparation of these drawings, care must be taken of the availability of resources in money, in men and in materials required for the successful completion of the new idea into an actual reality. In designing a machine component, it is necessary to have a good knowledge of many subjects such as Mathematics, Engineering Mechanics, Strength of Materials, Theory of Machines, Workshop Processes and Engineering Drawing.

Classifications of Machine Design

The machine design may be classified as follows:

1. Adaptive design. In most cases, the designer's work is concerned with adaptation of existing designs. This type of design needs no special knowledge or skill and can be attempted by designers of ordinary technical training. The designer only makes minor alternation or modification in the existing designs of the product.

2. Development design. This type of design needs considerable scientific training and design ability in order to modify the existing designs into a new idea by adopting a new material or different method of manufacture. In this case, though the designer starts from the existing design, but the final product may differ quite markedly from the original product.

3. New design. This type of design needs lot of research, technical ability and creative thinking. Only those designers who have personal qualities of a sufficiently high order can take up the work of a new design. The designs, depending upon the methods used, may be classified as follows:

(a) Rational design. This type of design depends upon mathematical formulae of principle of mechanics.

(b) Empirical design. This type of design depends upon empirical formulae based on the practice and past experience.

(c) Industrial design. This type of design depends upon the production aspects to manufacture any machine component in the industry.

- (d) **Optimum design.** It is the best design for the given objective function under the specified constraints. It may be achieved by minimising the undesirable effects.
- (e) **System design.** It is the design of any complex mechanical system like a motor car.
- (f) **Element design.** It is the design of any element of the mechanical system like piston, crankshaft, connecting rod, etc.
- (g) **Computer aided design.** This type of design depends upon the use of computer systems to assist in the creation, modification, analysis and optimisation of a design.

General Considerations in Machine Design

Following are the general considerations in designing a machine component:

1. Type of load and stresses caused by the load. The load, on a machine component, may act in several ways due to which the internal stresses are set up. The various types of load and stresses are discussed later.

2. Motion of the parts or kinematics of the machine. The successful operation of any machine depends largely upon the simplest arrangement of the parts which will give the motion required.

The motion of the parts may be:

- (a) Rectilinear motion which includes unidirectional and reciprocating motions.
- (b) Curvilinear motion which includes rotary, oscillatory and simple harmonic.
- (c) Constant velocity.
- (d) Constant or variable acceleration.

3. Selection of materials. It is essential that a designer should have a thorough knowledge of the properties of the materials and their behaviour under working conditions. Some of the important characteristics of materials are: strength, durability, flexibility, weight, resistance to heat and corrosion, ability to cast, welded or hardened, machinability, electrical conductivity, etc. The various types of engineering materials and their properties are discussed later.

4. Form and size of the parts. The form and size are based on judgment. The smallest practicable cross-section may be used, but it may be checked that the stresses induced in the designed cross-section are reasonably safe. In order to design any machine part for form and

size, it is necessary to know the forces which the part must sustain. It is also important to anticipate any suddenly applied or impact load which may cause failure.

5. *Frictional resistance and lubrication.* There is always a loss of power due to frictional resistance and it should be noted that the friction of starting is higher than that of running friction. It is, therefore, essential that a careful attention must be given to the matter of lubrication of all surfaces which move in contact with others, whether in rotating, sliding, or rolling bearings.

6. *Convenient and economical features.* In designing, the operating features of the machine should be carefully studied. The starting, controlling and stopping levers should be located on the basis of convenient handling. The adjustment for wear must be provided employing the various take up devices and arranging them so that the alignment of parts is preserved. If parts are to be changed for different products or replaced on account of wear or breakage, easy access should be provided and the necessity of removing other parts to accomplish this should be avoided if possible. The economical operation of a machine which is to be used for production or for the processing of material should be studied, in order to learn whether it has the maximum capacity consistent with the production of good work.

7. *Use of standard parts.* The use of standard parts is closely related to cost, because the cost of standard or stock parts is only a fraction of the cost of similar parts made to order. The standard or stock parts should be used whenever possible; parts for which patterns are already in existence such as gears, pulleys and bearings and parts which may be selected from regular shop stock such as screws, nuts and pins. Bolts and studs should be as few as possible to avoid the delay caused by changing drills, reamers and taps and also to decrease the number of wrenches required.

8. *Safety of operation.* Some machines are dangerous to operate, especially those which are speeded up to insure production at a maximum rate. Therefore, any moving part of a machine which is within the zone of a worker is considered an accident hazard and may be the cause of an injury. It is, therefore, necessary that a designer should always provide safety devices for the safety of the operator. The safety appliances should in no way interfere with operation of the machine.

9. *Workshop facilities.* A design engineer should be familiar with the limitations of this employer's workshop, in order to avoid the necessity of having work done in some other workshop. It is sometimes necessary to plan and supervise the workshop operations and to draft methods for casting, handling and machining special parts.

10. *Number of machines to be manufactured.* The number of articles or machines to be manufactured affects the design in a number of ways. The engineering and shop costs which are called fixed charges or overhead expenses are distributed over the number of articles to be manufactured. If only a few articles are to be made, extra expenses are not justified unless the machine is large or of some special design. An order calling for small number of the product will not permit any undue expense in the workshop processes, so that the designer should restrict his specification to standard parts as much as possible.

11. *Cost of construction.* The cost of construction of an article is the most important consideration involved in design. In some cases, it is quite possible that the high cost of an article may immediately bar it from further considerations. If an article has been invented and tests of handmade samples have shown that it has commercial value, it is then possible to justify the expenditure of a considerable sum of money in the design and development of automatic machines to produce the article, especially if it can be sold in large numbers. The aim of design engineer under all conditions should be to reduce the manufacturing cost to the minimum.

12. *Assembling.* Every machine or structure must be assembled as a unit before it can function. Large units must often be assembled in the shop, tested and then taken to be transported to their place of service. The final location of any machine is important and the design engineer must anticipate the exact location and the local facilities for erection.

General Procedure in Machine Design

In designing a machine component, there is no rigid rule. The problem may be attempted in several ways. However, the general procedure to solve a design problem is as follows:

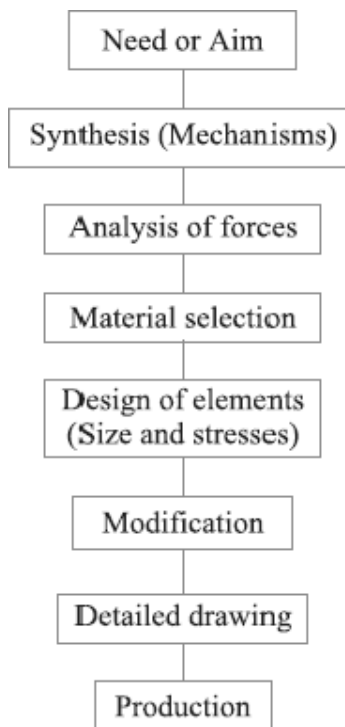

Fig.1. General Machine Design Procedure

- 1. *Recognition of need.*** First of all, make a complete statement of the problem, indicating the need, aim or purpose for which the machine is to be designed.
- 2. *Synthesis (Mechanisms).*** Select the possible mechanism or group of mechanisms which will give the desired motion.
- 3. *Analysis of forces.*** Find the forces acting on each member of the machine and the energy transmitted by each member.
- 4. *Material selection.*** Select the material best suited for each member of the machine.
- 5. *Design of elements (Size and Stresses).*** Find the size of each member of the machine by considering the force acting on the member and the permissible stresses for the material used. It should be kept in mind that each member should not deflect or deform than the permissible limit.

6. Modification. Modify the size of the member to agree with the past experience and judgment to facilitate manufacture. The modification may also be necessary by consideration of manufacturing to reduce overall cost.

7. Detailed drawing. Draw the detailed drawing of each component and the assembly of the machine with complete specification for the manufacturing processes suggested.

8. Production. The component, as per the drawing, is manufactured in the workshop. The flow chart for the general procedure in machine design is shown in Fig.

Note: When there are number of components in the market having the same qualities of efficiency, durability and cost, then the customer will naturally attract towards the most appealing product. The aesthetic and ergonomics are very important features which gives grace and lustre to product and dominates the market.

Engineering materials and their properties

The knowledge of materials and their properties is of great significance for a design engineer. The machine elements should be made of such a material which has properties suitable for the conditions of operation. In addition to this, a design engineer must be familiar with the effects which the manufacturing processes and heat treatment have on the properties of the materials. Now, we shall discuss the commonly used engineering materials and their properties in Machine Design.

Classification of Engineering Materials

The engineering materials are mainly classified as:

1. Metals and their alloys, such as iron, steel, copper, aluminum, etc.
2. Non-metals, such as glass, rubber, plastic, etc.

The metals may be further classified as:

- (a) Ferrous metals and (b) Non-ferrous metals.

The **ferrous metals* are those which have the iron as their main constituent, such as cast iron, wrought iron and steel.

The *non-ferrous* metals are those which have a metal other than iron as their main constituent, such as copper, aluminum, brass, tin, zinc, etc.

Selection of Materials for Engineering Purposes

The selection of a proper material, for engineering purposes, is one of the most difficult problems for the designer. The best material is one which serves the desired objective at the minimum cost. The following factors should be considered while selecting the material:

1. Availability of the materials,
2. Suitability of the materials for the working conditions in service, and
3. The cost of the materials.

The important properties, which determine the utility of the material, are physical, chemical and mechanical properties. We shall now discuss the physical and mechanical properties of the material in the following articles.

Physical Properties of Metals

The physical properties of the metals include luster, colour, size and shape, density, electric and thermal conductivity, and melting point. The following table shows the important physical properties of some pure metals.

Mechanical Properties of Metals

The mechanical properties of the metals are those which are associated with the ability of the material to resist mechanical forces and load. These mechanical properties of the metal include strength, stiffness, elasticity, plasticity, ductility, brittleness, malleability, toughness, resilience, creep and hardness. We shall now discuss these properties as follows:

1. Strength. It is the ability of a material to resist the externally applied forces without breaking or yielding. The internal resistance offered by a part to an externally applied force is called stress.

2. Stiffness. It is the ability of a material to resist deformation under stress. The modulus of elasticity is the measure of stiffness.

3. Elasticity. It is the property of a material to regain its original shape after deformation when the external forces are removed. This property is desirable for materials used in tools and machines. It may be noted that steel is more elastic than rubber.

4. Plasticity. It is property of a material which retains the deformation produced under load permanently. This property of the material is necessary for forgings, in stamping images on coins and in ornamental work.

5. Ductility. It is the property of a material enabling it to be drawn into wire with the application of a tensile force. A ductile material must be both strong and plastic. The ductility is usually measured by the terms, percentage elongation and percentage reduction in area. The ductile material commonly used in engineering practice (in order of diminishing ductility) are mild steel, copper, aluminium, nickel, zinc, tin and lead.

6. Brittleness. It is the property of a material opposite to ductility. It is the property of breaking of a material with little permanent distortion. Brittle materials when subjected to tensile loads snap off without giving any sensible elongation. Cast iron is a brittle material.

7. Malleability. It is a special case of ductility which permits materials to be rolled or hammered into thin sheets. A malleable material should be plastic but it is not essential to be so strong. The malleable materials commonly used in engineering practice (in order of diminishing malleability) are lead, soft steel, wrought iron, copper and aluminium.

8. Toughness. It is the property of a material to resist fracture due to high impact loads like hammer blows. The toughness of the material decreases when it is heated. It is measured by the amount of energy that a unit volume of the material has absorbed after being stressed upto the point of fracture. This property is desirable in parts subjected to shock and impact loads.

9. Machinability. It is the property of a material which refers to a relative ease with which a material can be cut. The machinability of a material can be measured in a number of ways such as comparing the tool life for cutting different materials or thrust required to remove the material at some given rate or the energy required to remove a unit volume of the material. It may be noted that brass can be easily machined than steel.

10. Resilience. It is the property of a material to absorb energy and to resist shock and impact loads. It is measured by the amount of energy absorbed per unit volume within elastic limit. This property is essential for spring materials.

11. Creep. When a part is subjected to a constant stress at high temperature for a long period of time, it will undergo a slow and permanent deformation called **creep**. This property is considered in designing internal combustion engines, boilers and turbines.

12. Fatigue. When a material is subjected to repeated stresses, it fails at stresses below the yield point stresses. Such type of failure of a material is known as ***fatigue**. The failure is caused by means of a progressive crack formation which are usually fine and of microscopic size. This property is considered in designing shafts, connecting rods, springs, gears, etc.

13. Hardness. It is a very important property of the metals and has a wide variety of meanings. It embraces many different properties such as resistance to wear, scratching, deformation and machinability etc. It also means the ability of a metal to cut another metal. The hardness is usually expressed in numbers which are dependent on the method of making the test. The hardness of a metal may be determined by the following tests:

- (a) Brinell hardness test,
- (b) Rockwell hardness test,
- (c) Vickers hardness (also called Diamond Pyramid) test, and
- (d) Shore scleroscope.

Steel

It is an alloy of iron and carbon, with carbon content up to a maximum of 1.5%. The carbon occurs in the form of iron carbide, because of its ability to increase the hardness and strength of the steel. Other elements *e.g.* silicon, sulphur, phosphorus and manganese are also present to greater or lesser amount to impart certain desired properties to it. Most of the steel produced now-a-days is **plain carbon steel** or simply **carbon steel**. A carbon steel is defined as a steel which has its properties mainly due to its carbon content and does not contain more than 0.5% of silicon and 1.5% of manganese.

The plain carbon steels varying from 0.06% carbon to 1.5% carbon are divided into the following types depending upon the carbon content.

1. Dead mild steel — up to 0.15% carbon

2. Low carbon or mild steel — 0.15% to 0.45% carbon
3. Medium carbon steel — 0.45% to 0.8% carbon
4. High carbon steel — 0.8% to 1.5% carbon

According to Indian standard *[IS: 1762 (Part-I)–1974], a new system of designating the steel is recommended. According to this standard, steels are designated on the following two basis: (a) On the basis of mechanical properties, and (b) On the basis of chemical composition. We shall now discuss, in detail, the designation of steel on the above two basis, in the following pages.

Steels Designated on the Basis of Mechanical Properties

These steels are carbon and low alloy steels where the main criterion in the selection and inspection of steel is the tensile strength or yield stress. According to Indian standard IS: 1570 (Part-I)- 1978 (Reaffirmed 1993), these steels are designated by a symbol 'Fe' or 'Fe E' depending on whether the steel has been specified on the basis of minimum tensile strength or yield strength, followed by the figure indicating the minimum tensile strength or yield stress in N/mm². For example 'Fe 290' means a steel having minimum tensile strength of 290 N/mm² and 'Fe E 220' means a steel having yield strength of 220 N/mm².

Steels Designated on the Basis of Chemical Composition

According to Indian standard, IS : 1570 (Part II/Sec I)-1979 (Reaffirmed 1991), the carbon steels are designated in the following order :

- (a) Figure indicating 100 times the average percentage of carbon content,
- (b) Letter 'C', and
- (c) Figure indicating 10 times the average percentage of manganese content. The figure after multiplying shall be rounded off to the nearest integer.

For example 20C8 means a carbon steel containing 0.15 to 0.25 per cent (0.2 per cent on average) carbon and 0.60 to 0.90 per cent (0.75 per cent rounded off to 0.8 per cent on an average) manganese.

Effect of Impurities on Steel

The following are the effects of impurities like silicon, sulphur, manganese and phosphorus on steel.

1. Silicon. The amount of silicon in the finished steel usually ranges from 0.05 to 0.30%. Silicon is added in low carbon steels to prevent them from becoming porous. It removes the gases and oxides, prevent blow holes and thereby makes the steel tougher and harder.

2. Sulphur. It occurs in steel either as iron sulphide or manganese sulphide. Iron sulphide because of its low melting point produces red shortness, whereas manganese sulphide does not affect so much. Therefore, manganese sulphide is less objectionable in steel than iron sulphide.

3. Manganese. It serves as a valuable deoxidising and purifying agent in steel. Manganese also combines with sulphur and thereby decreases the harmful effect of this element remaining in the steel. When used in ordinary low carbon steels, manganese makes the metal ductile and of good bending qualities. In high speed steels, it is used to toughen the metal and to increase its critical temperature.

4. Phosphorus. It makes the steel brittle. It also produces cold shortness in steel. In low carbon steels, it raises the yield point and improves the resistance to atmospheric corrosion. The sum of carbon and phosphorus usually does not exceed 0.25%.

Manufacturing considerations in Machine design Manufacturing Processes

The knowledge of manufacturing processes is of great importance for a design engineer.

The following are the various manufacturing processes used in Mechanical Engineering.

1. Primary shaping processes. The processes used for the preliminary shaping of the machine component are known as primary shaping processes. The common operations used for this process are casting, forging, extruding, rolling, drawing, bending, shearing, spinning, powder metal forming, squeezing, etc.

2. Machining processes. The processes used for giving final shape to the machine component, according to planned dimensions are known as machining processes. The common operations used for this process are turning, planning, shaping, drilling, boring, reaming, sawing, broaching, milling, grinding, hobbing, etc.

3. Surface finishing processes. The processes used to provide a good surface finish for the machine component are known as surface finishing processes. The common operations used for this process are polishing, buffing, honing, lapping, abrasive belt grinding, barrel tumbling, electroplating, super finishing, sheradizing, etc.

4. Joining processes. The processes used for joining machine components are known as joining processes. The common operations used for this process are welding, riveting, soldering, brazing, screw fastening, pressing, sintering, etc.

5. Processes effecting change in properties. These processes are used to impart certain specific properties to the machine components so as to make them suitable for particular operations or uses. Such processes are heat treatment, hot-working, cold-working and shot peening.

Other considerations in Machine design

1. Workshop facilities.
2. Number of machines to be manufactured
3. Cost of construction
4. Assembling

Interchangeability

The term interchangeability is normally employed for the mass production of identical items within the prescribed limits of sizes. A little consideration will show that in order to maintain the sizes of the part within a close degree of accuracy, a lot of time is required. But even then there will be small variations. If the variations are within certain limits, all parts of equivalent size will be equally fit for operating in machines and mechanisms. Therefore, certain variations are recognized and allowed in the sizes of the mating parts to give the required fitting. This facilitates to select at random from a large number of parts for an assembly and results in a considerable saving in the cost of production.

In order to control the size of finished part, with due allowance for error, for interchangeable parts is called **limit system**. It may be noted that when an assembly is made of two parts, the part which enters into the other, is known as **enveloped surface** (or **shaft** for cylindrical part) and the other in which one enters is called **enveloping surface** (or **hole** for cylindrical part). The term **shaft** refers not only to the diameter of a circular shaft, but it is also used to designate any external dimension of a part. The term **hole** refers not only to the diameter of a circular hole, but it is also used to designate any internal dimension of a part.

Important Terms used in Limit System

The following terms used in limit system (or interchangeable system) are important from the subject point of view:

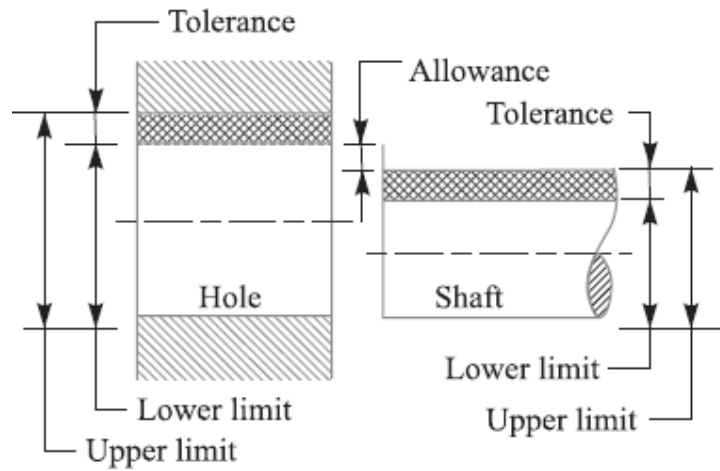

Fig. Limits of sizes.

1. **Nominal size.** It is the size of a part specified in the drawing as a matter of convenience.
2. **Basic size.** It is the size of a part to which all limits of variation (i.e. tolerances) are applied to arrive at final dimensioning of the mating parts. The nominal or basic size of a part is often the same.
3. **Actual size.** It is the actual measured dimension of the part. The difference between the basic size and the actual size should not exceed a certain limit; otherwise it will interfere with the interchangeability of the mating parts.
4. **Limits of sizes.** There are two extreme permissible sizes for a dimension of the part as shown in Fig. The largest permissible size for a dimension of the part is called **upper** or **high** or **maximum limit**, whereas the smallest size of the part is known as **lower** or **minimum limit**.
5. **Allowance.** It is the difference between the basic dimensions of the mating parts. The allowance may be **positive** or **negative**. When the shaft size is less than the hole size, then the allowance is **positive** and when the shaft size is greater than the hole size, then the allowance is **negative**.



(a) Unilateral tolerance.



(b) Bilateral tolerance.

Fig. Method of assigning Tolerances

6. Tolerance. It is the difference between the upper limit and lower limit of a dimension. In other words, it is the maximum permissible variation in a dimension. The tolerance may be **unilateral** or **bilateral**. When all the tolerance is allowed on one side of the nominal size, e.g. $20^{+0.004}$, then it is said to be **unilateral system of tolerance**. The unilateral system is mostly used in industries as it permits changing the tolerance value while still retaining the same allowance or type of fit. When the tolerance is allowed on both sides of the nominal size, e.g. $20^{+0.002}_{-0.002}$, then it is said to be **bilateral system of tolerance**. In this case $+0.002$ is the upper limit and -0.002 is the lower limit.

7. Tolerance zone. It is the zone between the maximum and minimum limit size.

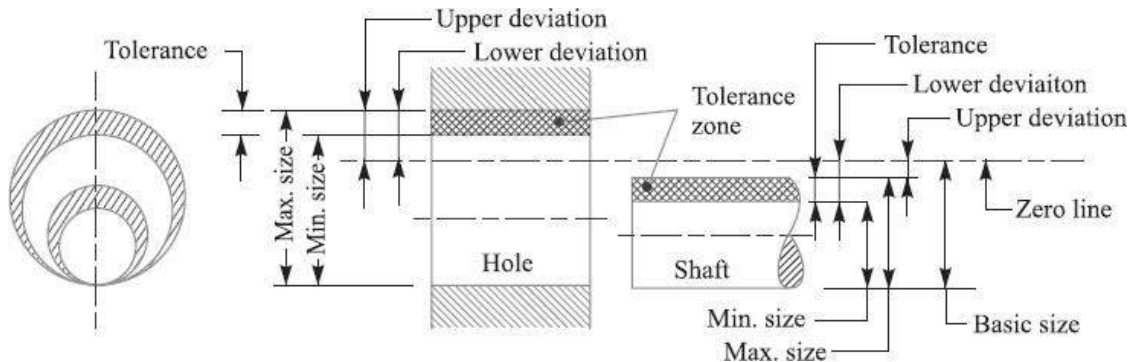

Fig. Tolerance Zone

8. Zero line. It is a straight line corresponding to the basic size. The deviations are measured from this line. The positive and negative deviations are shown above and below the zero line respectively.

9. Upper deviation. It is the algebraic difference between the maximum size and the basic size. The upper deviation of a hole is represented by a symbol ES (Ecart Superior) and of a shaft, it is represented by es .

10. Lower deviation. It is the algebraic difference between the minimum size and the basic size. The lower deviation of a hole is represented by a symbol EI (Ecart Inferior) and of a shaft, it is represented by ei .

11. Actual deviation. It is the algebraic difference between an actual size and the corresponding basic size.

12. Mean deviation. It is the arithmetical mean between the upper and lower deviations.

13. Fundamental deviation. It is one of the two deviations which are conventionally chosen to define the position of the tolerance zone in relation to zero line, as shown in Fig.

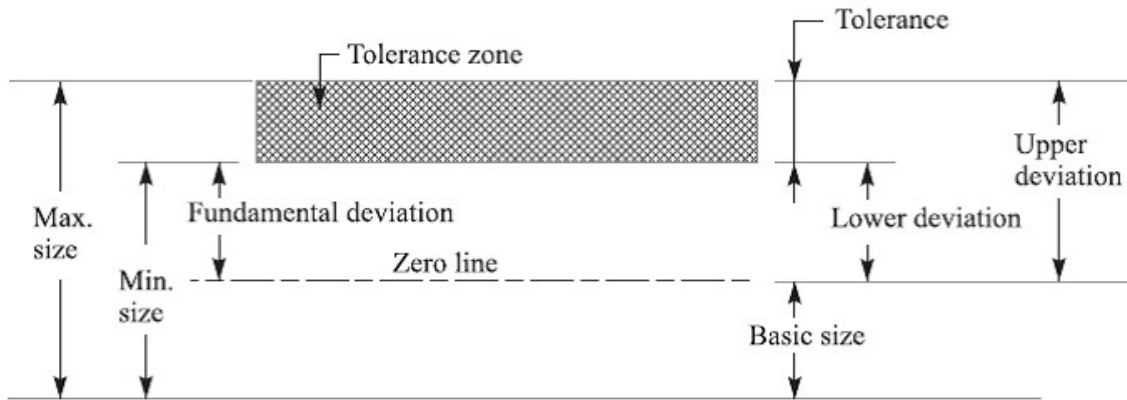

Fig. Fundamental deviation.

Fits

The degree of tightness or looseness between the two mating parts is known as a *fit* of the parts. The nature of fit is characterized by the presence and size of clearance and interference. The **clearance** is the amount by which the actual size of the shaft is less than the actual size of the mating hole in an assembly as shown in Fig. 3.5 (a). In other words, the clearance is the difference between the sizes of the hole and the shaft before assembly. The difference must be **positive**.

The **clearance** is the amount by which the actual size of the shaft is less than the actual size of the mating hole in an assembly as shown in Fig. (a). In other words, the clearance is the difference between the sizes of the hole and the shaft before assembly. The difference must be **positive**.

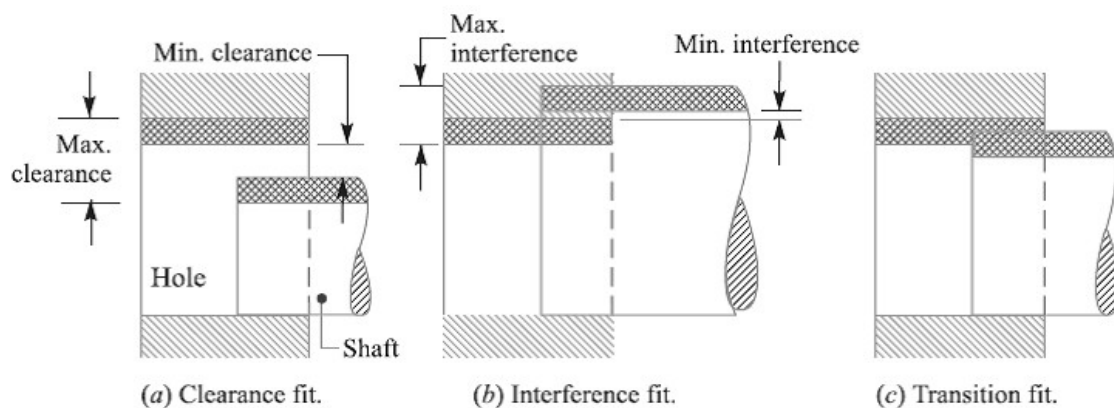

Fig. Types of fits.

The **interference** is the amount by which the actual size of a shaft is larger than the actual finished size of the mating hole in an assembly as shown in Fig. (b). In other words, the

interference is the arithmetical difference between the sizes of the hole and the shaft, before assembly. The difference must be *negative*.

Types of Fits

According to Indian standards, the fits are classified into the following three groups:

1. Clearance fit. In this type of fit, the size limits for mating parts are so selected that clearance between them always occur, as shown in Fig. (a). It may be noted that in a clearance fit, the tolerance zone of the hole is entirely above the tolerance zone of the shaft. In a clearance fit, the difference between the minimum size of the hole and the maximum size of the shaft is known as *minimum clearance* whereas the difference between the maximum size of the hole and minimum size of the shaft is called *maximum clearance* as shown in Fig. (a). The clearance fits may be slide fit, easy sliding fit, running fit, slack running fit and loose running fit.

2. Interference fit. In this type of fit, the size limits for the mating parts are so selected that interference between them always occur, as shown in Fig. (b). It may be noted that in an interference fit, the tolerance zone of the hole is entirely below the tolerance zone of the shaft. In an interference fit, the difference between the maximum size of the hole and the minimum size of the shaft is known as *minimum interference*, whereas the difference between the minimum size of the hole and the maximum size of the shaft is called *maximum interference*, as shown in Fig. (b).

The interference fits may be shrink fit, heavy drive fit and light drive fit.

3. Transition fit. In this type of fit, the size limits for the mating parts are so selected that either a clearance or interference may occur depending upon the actual size of the mating parts, as shown in Fig. (c). It may be noted that in a transition fit, the tolerance zones of hole and shaft overlap. The transition fits may be force fit, tight fit and push fit.

Basis of Limit System

The following are two bases of limit system:

1. **Hole basis system.** When the hole is kept as a constant member (*i.e.* when the lower deviation of the hole is zero) and different fits are obtained by varying the shaft size, as shown in Fig. (a), then the limit system is said to be on a hole basis.

2. **Shaft basis system.** When the shaft is kept as a constant member (i.e. when the upper deviation of the shaft is zero) and different fits are obtained by varying the hole size, as shown in Fig.(b), Then the limit system is said to be on a shaft basis.

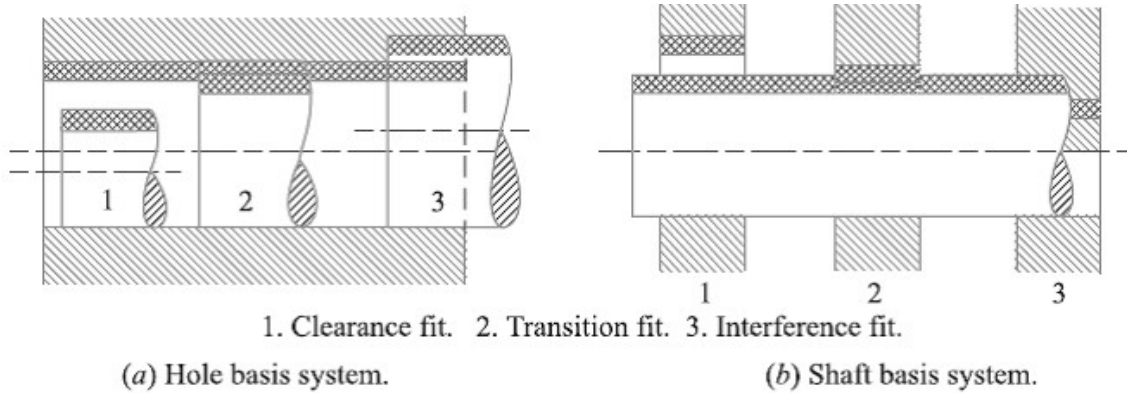

Fig. Bases of Limit System.

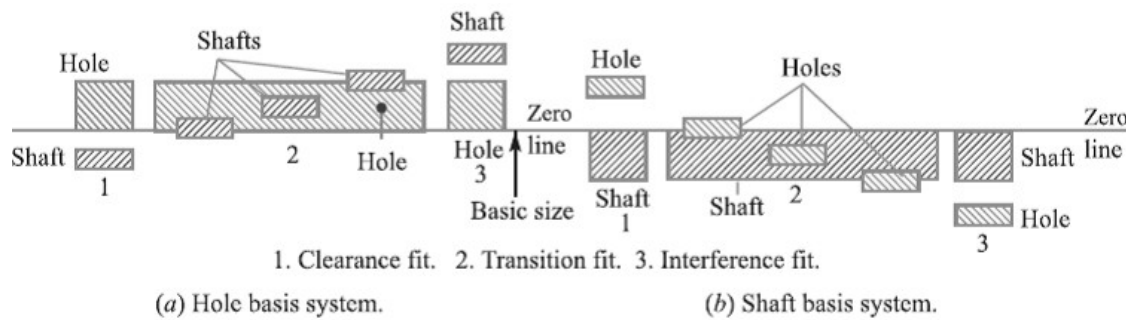

Fig. Bases of Limit System

The hole basis and shaft basis system may also be shown as in Fig. with respect to the zero line. It may be noted that from the manufacturing point of view, a hole basis system is always preferred. This is because the holes are usually produced and finished by standard tooling like drill, reamers, etc., whose size is not adjustable easily. On the other hand, the size of the shaft (which is to go into the hole) can be easily adjusted and is obtained by turning or grinding operations.

Solution: Given : Lower limit of hole = 25 mm ; Upper limit of hole = 25.02 mm ;
Upper limit of shaft = 24.97 mm ; Lower limit of shaft = 24.95 mm

Hole tolerance

Problem 1: We know that hole tolerance

$$= \text{Upper limit of hole} - \text{Lower limit of hole}$$

The dimensions of the mating parts, according to basic hole system, are given as follows:

Hole : 25.00 mm Shaft : 24.97 mm

Shaft tolerance

$$= 25.02 - 25 = 0.02 \text{ mm Ans.}$$

We know that shaft tolerance and allowance.

$$= \text{Upper limit of shaft} - \text{Lower limit of shaft}$$

$$= 24.97 - 24.95 = 0.02 \text{ mm Ans.}$$

Allowance

We know that allowance

$$= \text{Lower limit of hole} - \text{Upper limit of shaft}$$

$$= 25.00 - 24.97 = 0.03 \text{ mm Ans.}$$

Problem-2:

Calculate the tolerances, fundamental deviations and limits of sizes for the shaft designated as 40 H8 / f7.

Solution. Given: Shaft designation = 40 H8 / f7

The shaft designation 40 H8 / f7 means that the basic size is 40 mm and the tolerance grade for the hole is 8 (i.e. IT 8) and for the shaft is 7 (i.e. IT 7).

Tolerances

Since 40 mm lies in the diameter steps of 30 to 50 mm, therefore the geometric mean diameter,

$$D = \sqrt{30 \times 50} = 38.73 \text{ mm}$$

We know that standard tolerance unit,

$$\begin{aligned} i &= 0.45 \sqrt[3]{D} + 0.001 D \\ &= 0.45 \sqrt[3]{38.73} + 0.001 \times 38.73 \\ &= 0.45 \times 3.38 + 0.03873 = 1.559 73 \text{ or } 1.56 \text{ microns} \\ &= 1.56 \times 0.001 = 0.001 56 \text{ mm} \quad \dots(\because 1 \text{ micron} = 0.001 \text{ mm}) \end{aligned}$$

From Table 3.2, we find that standard tolerance for the hole of grade 8 (IT 8)

$$= 25 i = 25 \times 0.001 56 = 0.039 \text{ mm Ans.}$$

and standard tolerance for the shaft of grade 7 (IT 7)

$$= 16 i = 16 \times 0.001 56 = 0.025 \text{ mm Ans.}$$

Fundamental deviation

We know that fundamental deviation (lower deviation) for hole H ,

$$EI = 0$$

From Table 3.7, we find that fundamental deviation (upper deviation) for shaft f ,

$$\begin{aligned} es &= -5.5 (D)^{0.41} \\ &= -5.5 (38.73)^{0.41} = -24.63 \text{ or } -25 \text{ microns} \\ &= -25 \times 0.001 = -0.025 \text{ mm Ans.} \end{aligned}$$

∴ Fundamental deviation (lower deviation) for shaft f ,

$$ei = es - IT = -0.025 - 0.025 = -0.050 \text{ mm Ans.}$$

The -ve sign indicates that fundamental deviation lies below the zero line.

Limits of sizes

We know that lower limit for hole

$$= \text{Basic size} = 40 \text{ mm Ans.}$$

Upper limit for hole = Lower limit for hole + Tolerance for hole

$$= 40 + 0.039 = 40.039 \text{ mm Ans.}$$

Upper limit for shaft = Lower limit for hole or Basic size - Fundamental deviation

(upper deviation) ... (∵ Shaft f lies below the zero line)

$$= 40 - 0.025 = 39.975 \text{ mm Ans.}$$

and lower limit for shaft = Upper limit for shaft - Tolerance for shaft

$$= 39.975 - 0.025 = 39.95 \text{ mm Ans.}$$

Problem-3:

A journal of nominal or basic size of 75 mm runs in a bearing with close running fit. Find the limits of shaft and bearing. What is the maximum and minimum clearance?

Solution. Given: Nominal or basic size = 75 mm

From Table 3.5, we find that the close running fit is represented by $H 8/g 7$, i.e. a shaft $g 7$ should be used with $H 8$ hole.

Since 75 mm lies in the diameter steps of 50 to 80 mm, therefore the geometric mean diameter,

$$D = \sqrt{50 \times 80} = 63 \text{ mm}$$

We know that standard tolerance unit,

$$\begin{aligned} i &= 0.45 \sqrt[3]{D} + 0.001 D = 0.45 \sqrt[3]{63} + 0.001 \times 63 \\ &= 1.79 + 0.063 = 1.853 \text{ micron} \\ &= 1.853 \times 0.001 = 0.001 853 \text{ mm} \end{aligned}$$

∴ Standard tolerance for hole ' H ' of grade 8 ($IT 8$)

$$= 25 i = 25 \times 0.001 853 = 0.046 \text{ mm}$$

and standard tolerance for shaft ' g ' of grade 7 ($IT 7$)

$$= 16 i = 16 \times 0.001 853 = 0.03 \text{ mm}$$

From Table 3.7, we find that upper deviation for shaft g ,

$$\begin{aligned} es &= -2.5 (D)^{0.34} = -2.5 (63)^{0.34} = -10 \text{ micron} \\ &= -10 \times 0.001 = -0.01 \text{ mm} \end{aligned}$$

∴ Lower deviation for shaft g_s ,

$$e_i = e_s - IT = -0.01 - 0.03 = -0.04 \text{ mm}$$

We know that lower limit for hole

$$= \text{Basic size} = 75 \text{ mm}$$

Upper limit for hole = Lower limit for hole + Tolerance for hole

$$= 75 + 0.046 = 75.046 \text{ mm}$$

Upper limit for shaft = Lower limit for hole – Upper deviation for shaft

... (∵ Shaft g lies below zero line)

$$= 75 - 0.01 = 74.99 \text{ mm}$$

and lower limit for shaft = Upper limit for shaft – Tolerance for shaft

$$= 74.99 - 0.03 = 74.96 \text{ mm}$$

We know that maximum clearance

$$= \text{Upper limit for hole} - \text{Lower limit for shaft}$$

$$= 75.046 - 74.96 = 0.086 \text{ mm Ans.}$$

and minimum clearance = Lower limit for hole – Upper limit for shaft

$$= 75 - 74.99 = 0.01 \text{ mm Ans.}$$

Stress

When some external system of forces or loads acts on a body, the internal forces (equal and opposite) are set up at various sections of the body, which resist the external forces. This internal force per unit area at any section of the body is known as **unit stress** or simply a **stress**. It is denoted by a Greek letter sigma (σ). Mathematically,

$$\text{Stress, } (\sigma) \text{ Mathematically, } = P/A$$

Where P = Force or load acting on a body, and

A = Cross-sectional area of the body.

In S.I. units, the stress is usually expressed in Pascal (Pa) such that $1 \text{ Pa} = 1 \text{ N/m}^2$. In actual practice, we use bigger units of stress *i.e.* megapascal (MPa) and gigapascal (GPa), such

$$\text{that } 1 \text{ MPa} = 1 \times 10^6 \text{ N/m}^2 = 1 \text{ N/mm}^2$$

$$\text{And } 1 \text{ GPa} = 1 \times 10^9 \text{ N/m}^2 = 1 \text{ kN/mm}^2$$

Strain

When a system of forces or loads act on a body, it undergoes some deformation. This deformation per unit length is known as **unit strain** or simply a **strain**. It is denoted by a Greek letter epsilon (ϵ). Mathematically,

$$\text{Strain, } (\epsilon) = \delta l / l \quad \text{or } \delta l = \epsilon \cdot l$$

Where δl = Change in length of the body, and

l = Original length of the body.

Tensile Stress and Strain

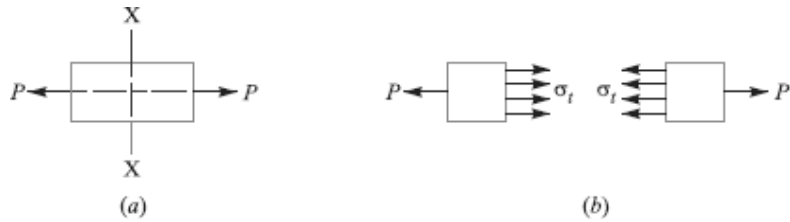

Fig. Tensile stress and strain

When a body is subjected to two equal and opposite axial pulls P (also called tensile load) as shown in Fig. (a), then the stress induced at any section of the body is known as **tensile stress**

as shown in Fig. (b). A little consideration will show that due to the tensile load, there will be a decrease in cross-sectional area and an increase in length of the body. The ratio of the increase in length to the original length is known as **tensile strain**.

Let P = Axial tensile force acting on the body,

A = Cross-sectional area of the body,

l = Original length, and

δl = Increase in length. Then

Tensile stress, $\sigma_t = P/A$

and tensile strain, $\epsilon_t = \delta l / l$

Young's Modulus or Modulus of Elasticity

Hooke's law* states that when a material is loaded within elastic limit, the stress is directly proportional to strain, *i.e.*

$$\sigma \propto \epsilon \quad \text{or} \quad \sigma = E \cdot \epsilon$$

$$E = \frac{\sigma}{\epsilon} = \frac{P \times l}{A \times \delta l}$$

where E is a constant of proportionality known as **Young's modulus** or **modulus of elasticity**. In S.I. units, it is usually expressed in GPa *i.e.* GN/m² or kN/mm². It may be noted that Hooke's law holds good for tension as well as compression.

The following table shows the values of modulus of elasticity or Young's modulus (E) for the materials commonly used in engineering practice.

Values of E for the commonly used engineering materials.

Material	Modulus of elasticity (E) in GPa i.e. GN/m ² for kN/mm ²
Steel and Nickel	200 to 220
Wrought iron	190 to 200
Cast iron	100 to 160
Copper	90 to 110
Brass	80 to 90
Aluminium	60 to 80
Timber	10

Shear Stress and Strain

When a body is subjected to two equal and opposite forces acting tangentially across the resisting section, as a result of which the body tends to shear off the section, then the stress induced is called *shear stress*.

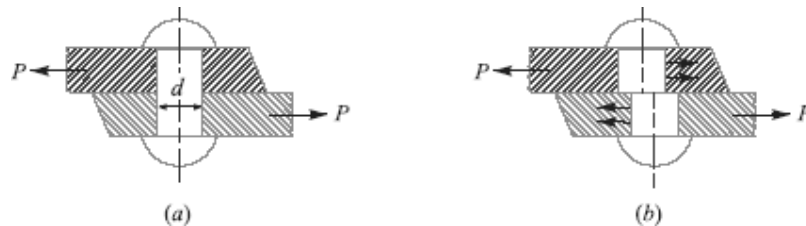

Fig. Single shearing of a riveted joint.

The corresponding strain is known as *shear strain* and it is measured by the angular deformation accompanying the shear stress. The shear stress and shear strain are denoted by the Greek letters tau (τ) and phi (ϕ) respectively. Mathematically,

$$\text{Shear stress } (\tau) = \frac{\text{Tangential force}}{\text{Resisting area}}$$

Consider a body consisting of two plates connected by a rivet as shown in Fig. (a). In this case, the tangential force P tends to shear off the rivet at one cross-section as shown in Fig. (b). It may be noted that when the tangential force is resisted by one cross-section of the rivet (or when shearing takes place at one cross-section of the rivet), then the rivets are said to be in *single shear*. In such a case, the area resisting the shear off the rivet,

$$A = d^2$$

And shear stress on the rivet cross-section

$$\frac{P}{A} = \frac{P}{\frac{\pi d^2}{4}} = \frac{4P}{\pi d^2}$$

Now let us consider two plates connected by the two cover plates as shown in Fig. (a). In this case, the tangential force P tends to shear off the rivet at two cross-sections as shown in Fig. (b). It may be noted that when the tangential force is resisted by two cross-sections of the rivet (or when the shearing takes place at two cross-sections of the rivet), then the rivets are said to be in *double shear*. In such a case, the area resisting the shear of the rivet,

$$A = 2 \times \frac{\pi d^2}{4} \quad (\text{For double shear})$$

and shear stress on the rivet cross-section.

$$\tau = \frac{P}{A} = \frac{P}{2 \times \frac{\pi}{4} \times d^2} = \frac{2P}{\pi d^2}$$

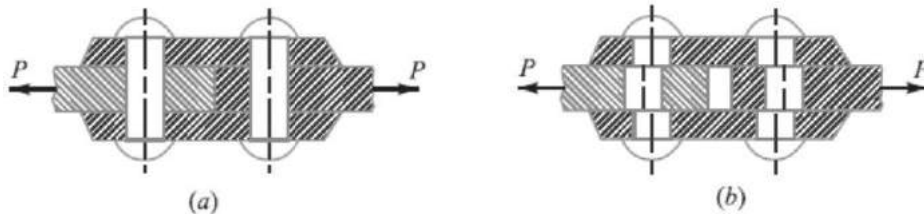

Fig. Double shearing of a riveted joint.

Notes:

1. All lap joints and single cover butt joints are in single shear, while the butt joints with double cover plates are in double shear.
2. In case of shear, the area involved is parallel to the external force applied.
3. When the holes are to be punched or drilled in the metal plates, then the tools used to perform the operations must overcome the ultimate shearing resistance of the material to be cut. If a hole of diameter ' d ' is to be punched in a metal plate of thickness ' t ', then the area to be sheared,

$$A = \pi d \times t$$

And the maximum shear resistance of the tool or the force required to punch a hole,

$$P = A \times \tau_u = \pi d \times t \times \tau_u$$

Where τ_u = Ultimate shear strength of the material of the plate.

Shear Modulus or Modulus of Rigidity

It has been found experimentally that within the elastic limit, the shear stress is directly proportional to shear strain. Mathematically

$$\tau \propto \phi \quad \text{or} \quad \tau = C \cdot \phi \quad \text{or} \quad \tau / \phi = C$$

Where τ = Shear stress,

ϕ respectively. Mathematically, = Shear strain, and

C = Constant of proportionality, known as shear modulus or modulus of rigidity. It is also denoted by N or G .

The following table shows the values of modulus of rigidity (C) for the materials in everyday use:

Values of C for the commonly used materials

Material	Modulus of rigidity (C) in GPa i.e. GN/m^2 or kNm m^2
Steel	80 to 100
Wrought iron	80 to 90
Cast iron	40 to 50
Copper	30 to 50
Brass	30 to 50
Timber	10

Linear and Lateral Strain

Consider a circular bar of diameter d and length l , subjected to a tensile force P as shown in Fig. (a).

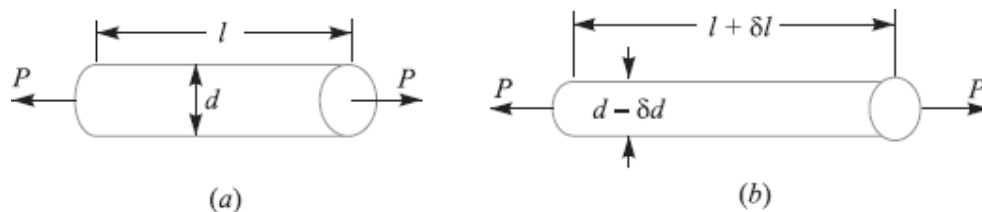

Fig. Linear and lateral strain.

A little consideration will show that due to tensile force, the length of the bar increases by an amount δl and the diameter decreases by an amount δd , as shown in Fig. (b). Similarly, if the bar is subjected to a compressive force, the length of the bar will decrease which will be followed by an increase in diameter.

It is thus obvious, that every direct stress is accompanied by a strain in its own direction which is known as **linear strain** and an opposite kind of strain in every direction, at right angles to it, is known as **lateral strain**.

4.18 Poisson's Ratio

It has been found experimentally that when a body is stressed within elastic limit, the lateral strain bears a constant ratio to the linear strain, Mathematically,

$$\frac{\text{Lateral Strain}}{\text{Linear Strain}} = \text{Constant}$$

This constant is known as **Poisson's ratio** and is denoted by $1/m$ or ν .

Following are the values of Poisson's ratio for some of the materials commonly used in engineering practice.

Values of Poisson's ratio for commonly used materials

S.No.	Material	Poisson 's ratio ($1/m$ or ν)
1	Steel	0.25 to 0.33
2	Cast iron	0.23 to 0.27
3	Copper	0.31 to 0.34
4	Brass	0.32 to 0.42
5	Aluminium	0.32 to 0.36
6	Concrete	0.08 to 0.18
7	Rubber	0.45 to 0.50

Volumetric Strain

When a body is subjected to a system of forces, it undergoes some changes in its dimensions. In other words, the volume of the body is changed. The ratio of the change in volume to the original volume is known as **volumetric strain**. Mathematically, volumetric strain,

$$\nu = \frac{\delta V}{V}$$

Where δV = Change in volume, and V = Original volume

Notes : 1. Volumetric strain of a rectangular body subjected to an axial force is given as

$$\epsilon_v = \frac{\delta V}{V} = \epsilon \left(1 - \frac{2}{m} \right); \text{ where } \epsilon = \text{Linear strain.}$$

2. Volumetric strain of a rectangular body subjected to three mutually perpendicular forces is given by

$$\epsilon_v = \epsilon_x + \epsilon_y + \epsilon_z$$

where ϵ_x , ϵ_y and ϵ_z are the strains in the directions x -axis, y -axis and z -axis respectively.

Bulk Modulus

When a body is subjected to three mutually perpendicular stresses, of equal intensity, then the ratio of the direct stress to the corresponding volumetric strain is known as **bulk modulus**. It is usually denoted by K . Mathematically, bulk modulus,

$$K = \frac{\text{Direct stress}}{\text{Volumetric strain}} = \frac{\sigma}{\delta V/V}$$

Relation Between Bulk Modulus and Young's Modulus

The bulk modulus (K) and Young's modulus (E) are related by the following relation,

$$K = \frac{m.E}{3(m-2)} = \frac{E}{3(1-2\mu)}$$

Relation between Young's Modulus and Modulus of Rigidity

The Young's modulus (E) and modulus of rigidity (G) are related by the following relation,

$$G = \frac{m.E}{2(m+1)} = \frac{E}{2(1+\mu)}$$

Factor of Safety

It is defined, in general, as the **ratio of the maximum stress to the working stress**. Mathematically,

$$\text{Factor of safety} = \text{Maximum stress} / \text{Working or design stress}$$

In case of ductile materials *e.g.* mild steel, where the yield point is clearly defined, the factor of safety is based upon the yield point stress. In such cases,

$$\text{Factor of safety} = \text{Yield point stress} / \text{Working or design stress}$$

In case of brittle materials *e.g.* cast iron, the yield point is not well defined as for ductile materials. Therefore, the factor of safety for brittle materials is based on ultimate stress.

Factor of safety = Ultimate stress/ Working or design stress This relation may also be used for ductile materials.

The above relations for factor of safety are for static loading.

Problem:

A steel bar 2.4 m long and 30 mm square is elongated by a load of 500 kN. If poisson's ratio is 0.25, find the increase in volume. Take $E = 0.2 \times 10^6 \text{ N/mm}^2$.

Solution. Given : $l = 2.4 \text{ m} = 2400 \text{ mm}$; $A = 30 \times 30 = 900 \text{ mm}^2$; $P = 500 \text{ kN} = 500 \times 10^3 \text{ N}$;
 $l/m = 0.25$; $E = 0.2 \times 10^6 \text{ N/mm}^2$

Let $\delta V =$ Increase in volume.

We know that volume of the rod,

$$V = \text{Area} \times \text{length} = 900 \times 2400 = 2160 \times 10^3 \text{ mm}^3$$

and Young's modulus, $E = \frac{\text{Stress}}{\text{Strain}} = \frac{P/A}{\epsilon}$

$$\therefore \epsilon = \frac{P}{A.E} = \frac{500 \times 10^3}{900 \times 0.2 \times 10^6} = 2.8 \times 10^{-3}$$

We know that volumetric strain,

$$\frac{\delta V}{V} = \epsilon \left(1 - \frac{2}{m} \right) = 2.8 \times 10^{-3} (1 - 2 \times 0.25) = 1.4 \times 10^{-3}$$

$$\therefore \delta V = V \times 1.4 \times 10^{-3} = 2160 \times 10^3 \times 1.4 \times 10^{-3} = 3024 \text{ mm}^3 \text{ Ans.}$$

Stresses due to Change in Temperature—Thermal Stresses

Whenever there is some increase or decrease in the temperature of a body, it causes the body to expand or contract. A little consideration will show that if the body is allowed to expand or contract freely, with the rise or fall of the temperature, no stresses are induced in the body.

But, if the deformation of the body is prevented, some stresses are induced in the body. Such stresses are known as **thermal stresses**.

Let $l =$ Original length of the body,
 $t =$ Rise or fall of temperature, and
 $\alpha =$ Coefficient of thermal expansion,
 $\delta l =$ Increase or decrease in length,

$$\delta l = l \cdot \alpha \cdot t$$

If the ends of the body are fixed to rigid supports, so that its expansion is prevented, then compressive strain induced in the body,

$$\epsilon_c = \frac{\delta l}{l} = \frac{l \cdot \alpha \cdot t}{l} = \alpha \cdot t$$

Thermal stress,

$$\sigma_{th} = \epsilon_c \cdot E = \alpha \cdot t \cdot E$$

1. When a body is composed of two or different materials having different coefficient of thermal expansions, then due to the rise in temperature, the material with higher coefficient of thermal expansion will be subjected to compressive stress whereas the material with low coefficient of expansion will be subjected to tensile stress.

2. When a thin tyre is shrunk on to a wheel of diameter D , its internal diameter d is a little less than the wheel diameter. When the tyre is heated, its circumference πd will increase to πD . In this condition, it is slipped on to the wheel. When it cools, it wants to return to its original circumference πd , but the wheel if it is assumed to be rigid, prevents it from doing so.

$$\text{Strain, } \epsilon = \frac{\pi D - \pi d}{\pi d} = \frac{D - d}{d}$$

This strain is known as *circumferential* or *hoop strain*.

Therefore, Circumferential or hoop stress,

$$\sigma = E \cdot \epsilon = \frac{E (D - d)}{d}$$

Problem:

A composite bar made of aluminium and steel is held between the supports as shown in Fig. The bars are stress free at a temperature of 37°C . What will be the stress in the two bars when the temperature is 20°C , if (a) the supports are unyielding; and (b) the supports yield and come nearer to each other by 0.10 mm ?

It can be assumed that the change of temperature is uniform all along the length of the bar. Take $E_s = 210\text{ GPa}$; $E_a = 74\text{ GPa}$; $\alpha_s = 11.7 \times 10^{-6} / ^\circ\text{C}$; and $\alpha_a = 23.4 \times 10^{-6} / ^\circ\text{C}$.

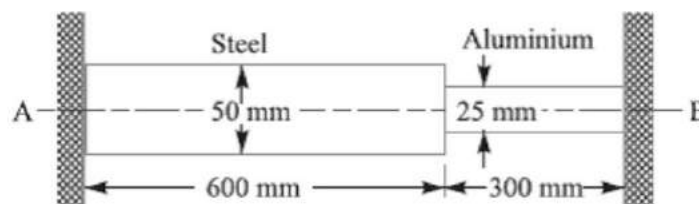

Solution. Given : $t_1 = 37^\circ\text{C}$; $t_2 = 20^\circ\text{C}$; $E_s = 210\text{ GPa} = 210 \times 10^9\text{ N/m}^2$; $E_a = 74\text{ GPa} = 74 \times 10^9\text{ N/m}^2$; $\alpha_s = 11.7 \times 10^{-6} / ^\circ\text{C}$; $\alpha_a = 23.4 \times 10^{-6} / ^\circ\text{C}$, $d_s = 50\text{ mm} = 0.05\text{ m}$; $d_a = 25\text{ mm} = 0.025\text{ m}$; $l_s = 600\text{ mm} = 0.6\text{ m}$; $l_a = 300\text{ mm} = 0.3\text{ m}$

Let us assume that the right support at B is removed and the bar is allowed to contract freely due to the fall in temperature. We know that the fall in temperature,

$$t = t_1 - t_2 = 37 - 20 = 17^\circ\text{C}$$

\therefore Contraction in steel bar

$$= \alpha_s \cdot l_s \cdot t = 11.7 \times 10^{-6} \times 600 \times 17 = 0.12\text{ mm}$$

and contraction in aluminium bar

$$= \alpha_a \cdot l_a \cdot t = 23.4 \times 10^{-6} \times 300 \times 17 = 0.12\text{ mm}$$

$$\text{Total contraction} = 0.12 + 0.12 = 0.24\text{ mm} = 0.24 \times 10^{-3}\text{ m}$$

It may be noted that even after this contraction (*i.e.* 0.24 mm) in length, the bar is still stress free as the right hand end was assumed free.

Let an axial force P is applied to the right end till this end is brought in contact with the right hand support at B , as shown in Fig.

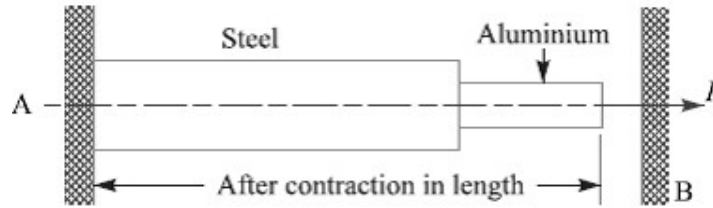

We know that cross-sectional area of the steel bar,

$$A_s = \frac{\pi}{4} (d_s)^2 = \frac{\pi}{4} (0.05)^2 = 1.964 \times 10^{-3} \text{ m}^2$$

and cross-sectional area of the aluminium bar,

$$A_a = \frac{\pi}{4} (d_a)^2 = \frac{\pi}{4} (0.025)^2 = 0.491 \times 10^{-3} \text{ m}^2$$

We know that elongation of the steel bar,

$$\begin{aligned} \delta l_s &= \frac{P \times l_s}{A_s \times E_s} = \frac{P \times 0.6}{1.964 \times 10^{-3} \times 210 \times 10^9} = \frac{0.6P}{412.44 \times 10^6} \text{ m} \\ &= 1.455 \times 10^{-9} P \text{ m} \end{aligned}$$

and elongation of the aluminium bar,

$$\begin{aligned} \delta l_a &= \frac{P \times l_a}{A_a \times E_a} = \frac{P \times 0.3}{0.491 \times 10^{-3} \times 74 \times 10^9} = \frac{0.3P}{36.334 \times 10^6} \text{ m} \\ &= 8.257 \times 10^{-9} P \text{ m} \end{aligned}$$

\therefore Total elongation,

$$\begin{aligned} \delta l &= \delta l_s + \delta l_a \\ &= 1.455 \times 10^{-9} P + 8.257 \times 10^{-9} P = 9.712 \times 10^{-9} P \text{ m} \end{aligned}$$

Let

$$\begin{aligned} \sigma_s &= \text{Stress in the steel bar, and} \\ \sigma_a &= \text{Stress in the aluminium bar.} \end{aligned}$$

(a) When the supports are unyielding

When the supports are unyielding, the total contraction is equated to the total elongation, *i.e.*

$$0.24 \times 10^{-3} = 9.712 \times 10^{-9} P \quad \text{or} \quad P = 24\,712 \text{ N}$$

\therefore Stress in the steel bar,

$$\begin{aligned} \sigma_s &= P/A_s = 24\,712 / (1.964 \times 10^{-3}) = 12\,582 \times 10^3 \text{ N/m}^2 \\ &= 12.582 \text{ MPa} \quad \text{Ans.} \end{aligned}$$

and stress in the aluminium bar,

$$\begin{aligned} \sigma_a &= P/A_a = 24\,712 / (0.491 \times 10^{-3}) = 50\,328 \times 10^3 \text{ N/m}^2 \\ &= 50.328 \text{ MPa} \quad \text{Ans.} \end{aligned}$$

(b) When the supports yield by 0.1 mm

When the supports yield and come nearer to each other by 0.10 mm, the net contraction in length

$$= 0.24 - 0.1 = 0.14 \text{ mm} = 0.14 \times 10^{-3} \text{ m}$$

Problem:

A copper bar 50 mm in diameter is placed within a steel tube 75 mm external diameter and 50 mm internal diameter of exactly the same length. The two pieces are rigidly fixed together by two pins 18 mm in diameter, one at each end passing through the bar and tube. Calculate the stress induced in the copper bar, steel tube and pins if the temperature of the combination is raised by 50°C. Take $E_s = 210 \text{ GN/m}^2$; $E_c = 105 \text{ GN/m}^2$; $\alpha_s = 11.5 \times 10^{-6}/^\circ\text{C}$ and $\alpha_c = 17 \times 10^{-6}/^\circ\text{C}$.

Solution. Given: $d_c = 50 \text{ mm}$; $d_{se} = 75 \text{ mm}$; $d_{si} = 50 \text{ mm}$; $d_p = 18 \text{ mm} = 0.018 \text{ m}$; $t = 50^\circ\text{C}$; $E_s = 210 \text{ GN/m}^2 = 210 \times 10^9 \text{ N/m}^2$; $E_c = 105 \text{ GN/m}^2 = 105 \times 10^9 \text{ N/m}^2$; $\alpha_s = 11.5 \times 10^{-6}/^\circ\text{C}$; $\alpha_c = 17 \times 10^{-6}/^\circ\text{C}$

The copper bar in a steel tube is shown in Fig. 4.18.

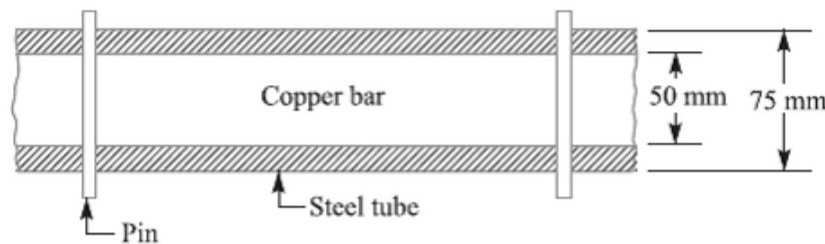

We know that cross-sectional area of the copper bar,

$$A_c = \frac{\pi}{4} (d_c)^2 = \frac{\pi}{4} (50)^2 = 1964 \text{ mm}^2 = 1964 \times 10^{-6} \text{ m}^2$$

and cross-sectional area of the steel tube,

$$A_s = \frac{\pi}{4} [(d_{se})^2 - (d_{si})^2] = \frac{\pi}{4} [(75)^2 - (50)^2] = 2455 \text{ mm}^2 = 2455 \times 10^{-6} \text{ m}^2$$

Let $l =$ Length of the copper bar and steel tube.

We know that free expansion of copper bar

$$= \alpha_c \cdot l \cdot t = 17 \times 10^{-6} \times l \times 50 = 850 \times 10^{-6} l$$

and free expansion of steel tube

$$= \alpha_s \cdot l \cdot t = 11.5 \times 10^{-6} \times l \times 50 = 575 \times 10^{-6} l$$

\therefore Difference in free expansion

$$= 850 \times 10^{-6} l - 575 \times 10^{-6} l = 275 \times 10^{-6} l \quad \dots(i)$$

Since the free expansion of the copper bar is more than the free expansion of the steel tube, therefore the copper bar is subjected to a compressive stress, while the steel tube is subjected to a tensile stress. Let a compressive force P newton on the copper bar opposes the extra expansion of the copper bar and an equal tensile force P on the steel tube pulls the steel tube so that the net effect of reduction in length of copper bar and the increase in length of steel tube equalizes the difference in free expansion of the two. Therefore, Reduction in length of copper bar due to force P

$$= \frac{P \cdot l}{A_c \cdot E_c}$$

$$= \frac{P.l}{1964 \times 10^{-6} \times 105 \times 10^9} = \frac{P.l}{206.22 \times 10^6} \text{ m}$$

and increase in length of steel bar due to force P

$$= \frac{P.l}{A_s \cdot E_s} = \frac{P.l}{2455 \times 10^{-6} \times 210 \times 10^9} = \frac{P.l}{515.55 \times 10^6} \text{ m}$$

$$\begin{aligned} \therefore \text{Net effect in length} &= \frac{P.l}{206.22 \times 10^6} + \frac{P.l}{515.55 \times 10^6} \\ &= 4.85 \times 10^{-9} P.l + 1.94 \times 10^{-9} P.l = 6.79 \times 10^{-9} P.l \end{aligned}$$

Equating this net effect in length to the difference in free expansion, we have

$$6.79 \times 10^{-9} P.l = 275 \times 10^{-6} l \quad \text{or} \quad P = 40\,500 \text{ N}$$

Stress induced in the copper bar, steel tube and pins

We know that stress induced in the copper bar,

$$\sigma_c = P / A_c = 40\,500 / (1964 \times 10^{-6}) = 20.62 \times 10^6 \text{ N/m}^2 = 20.62 \text{ MPa Ans.}$$

Stress induced in the steel tube,

$$\sigma_s = P / A_s = 40\,500 / (2455 \times 10^{-6}) = 16.5 \times 10^6 \text{ N/m}^2 = 16.5 \text{ MPa Ans.}$$

and shear stress induced in the pins,

$$\tau_p = \frac{P}{2 A_p} = \frac{40\,500}{2 \times \frac{\pi}{4} (0.018)^2} = 79.57 \times 10^6 \text{ N/m}^2 = 79.57 \text{ MPa Ans.}$$

...(\because The pin is in double shear)

Impact Stress

Sometimes, machine members are subjected to the load with impact. The stress produced in the member due to the falling load is known as **impact stress**. Consider a bar carrying a load W at a height h and falling on the collar provided at the lower end, as shown in Fig.

Let A = Cross-sectional area of the bar,

E = Young's modulus of the material of the bar,

l = Length of the bar,

δl = Deformation of the bar,

P = Force at which the deflection δl is produced,

σ_i = Stress induced in the bar due to the application of impact load,

and h = Height through which the load falls.

We know that energy gained by the system in the form of strain energy

$$= \frac{1}{2} \times P \times \delta l$$

And potential energy lost by the weight

$$= W(h + \delta l)$$

Since the energy gained by the system is equal to the potential energy lost by the weight, therefore

$$\begin{aligned} \frac{1}{2} \times P \times \delta l &= W(h + \delta l) \\ \frac{1}{2} \sigma_i \times A \times \frac{\sigma_i \times l}{E} &= W \left(h + \frac{\sigma_i \times l}{E} \right) \quad \dots \left[\because P = \sigma_i \times A, \text{ and } \delta l = \frac{\sigma_i \times l}{E} \right] \\ \therefore \frac{Al}{2E} (\sigma_i)^2 - \frac{Wl}{E} (\sigma_i) - Wh &= 0 \end{aligned}$$

From this quadratic equation, we find that

$$\sigma_i = \frac{W}{A} \left(1 + \sqrt{1 + \frac{2hAE}{Wl}} \right) \quad \dots \text{ [Taking +ve sign for maximum value]}$$

When $h = 0$, then $\sigma_i = 2W/A$. This means that the stress in the bar when the load is applied suddenly is double of the stress induced due to gradually applied load.

Problem:

An unknown weight falls through 10 mm on a collar rigidly attached to the lower end of a vertical bar 3 m long and 600 mm² in section. If the maximum instantaneous extension is known to be 2 mm, what is the corresponding stress and the value of unknown weight?

Take $E = 200 \text{ kN/mm}^2$.

Resilience

When a body is loaded within elastic limit, it changes its dimensions and on the removal of the load, it regains its original dimensions. So long as it remains loaded, it has stored energy in itself. On removing the load, the energy stored is given off as in the case of a spring. This energy, which is absorbed in a body when strained within elastic limit, is known as **strain energy**. The strain energy is always capable of doing some work.

The strain energy stored in a body due to external loading, within elastic limit, is known as **resilience** and the maximum energy which can be stored in a body up to the elastic limit is called **proof resilience**. The proof resilience per unit volume of a material is known as

modulus of resilience. It is an important property of a material and gives capacity of the material to bear impact or shocks. Mathematically, strain energy stored in a body due to tensile or compressive load or resilience,

$$U = \frac{\sigma^2 \times V}{2E}$$

And Modulus of resilience

$$= \frac{\sigma^2}{2E}$$

Where σ , Mathematically, = Tensile or compressive stress,

V = Volume of the body, and

E = Young's modulus of the material of the body.

When a body is subjected to a shear load, then modulus of resilience (shear)

$$= \frac{\tau^2}{2C}$$

Where τ and C respectively, Mathematically, = Shear stress, and

C = Modulus of rigidity.

When the body is subjected to torsion, then modulus of resilience

$$= \frac{\tau^2}{4C}$$

Solution. Given : $d = 50 \text{ mm}$; $l = 2.5 \text{ m} = 2500 \text{ mm}$; $U = 100 \text{ N-m} = 100 \times 10^3 \text{ N-mm}$;

$E = 200 \text{ GN/m}^2 = 200 \times 10^3 \text{ N/mm}^2$

A wrought iron bar 50 mm in diameter and 2.5 m long transmits shock energy of 100 N-m.

Maximum instantaneous stress

Find the maximum instantaneous stress and the elongation. Take $E = 200 \text{ GN/m}^2$.

Let σ = Maximum instantaneous stress.

We know that volume of the bar,

$$V = \frac{\pi}{4} \times d^2 \times l = \frac{\pi}{4} (50)^2 \times 2500 = 4.9 \times 10^6 \text{ mm}^3$$

We also know that shock or strain energy stored in the body (U),

$$100 \times 10^3 = \frac{\sigma^2 \times V}{2E} = \frac{\sigma^2 \times 4.9 \times 10^6}{2 \times 200 \times 10^3} = 12.25 \sigma^2$$

$$\therefore \sigma^2 = 100 \times 10^3 / 12.25 = 8163 \text{ or } \sigma = 90.3 \text{ N/mm}^2 \text{ Ans.}$$

Elongation produced

Let δl = Elongation produced.

We know that Young's modulus,

$$E = \frac{\text{Stress}}{\text{Strain}} = \frac{\sigma}{\epsilon} = \frac{\sigma}{\delta l / l}$$

$$\therefore \delta l = \frac{\sigma \times l}{E} = \frac{90.3 \times 2500}{200 \times 10^3} = 1.13 \text{ mm Ans.}$$

Torsional Shear Stress

When a machine member is subjected to the action of two equal and opposite couples acting in parallel planes (or torque or twisting moment), then the machine member is said to be subjected to **torsion**. The stress set up by torsion is known as **torsional shear stress**. It is zero at the centroidal axis and maximum at the outer surface. Consider a shaft fixed at one end and subjected to a torque (T) at the other end as shown in Fig. As a result of this torque, every cross-section of the shaft is subjected to torsional shear stress. We have discussed above that the torsional shear stress is zero at the centroidal axis and maximum at the outer surface. The maximum torsional shear stress at the outer surface of the shaft may be obtained from the following equation:

$$\frac{\tau}{r} = \frac{T}{J} = \frac{C \cdot \theta}{l} \dots\dots\dots(i)$$

Where τ and θ respectively, = Torsional shear stress induced at the outer surface of the shaft or maximum shear stress,

r = Radius of the shaft,

T = Torque or twisting moment,

J = Second moment of area of the section about its polar axis or polar moment of inertia,

C = Modulus of rigidity for the shaft material,

l = Length of the shaft, and

θ = Angle of twist in radians on a length l .

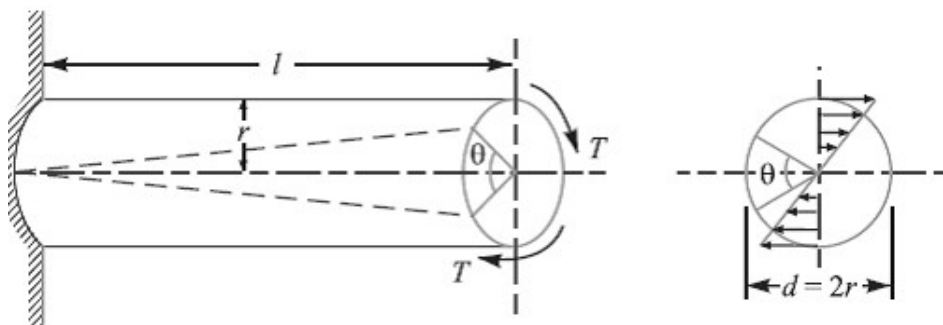

The above equation is known as **torsion equation**. It is based on the following assumptions:

1. The material of the shaft is uniform throughout.
2. The twist along the length of the shaft is uniform.
3. The normal cross-sections of the shaft, which were plane and circular before twist, remain plane and circular after twist.
4. All diameters of the normal cross-section which were straight before twist, remain straight with their magnitude unchanged, after twist.
5. The maximum shear stress induced in the shaft due to the twisting moment does not exceed its elastic limit value.

Note: 1. Since the torsional shear stress on any cross-section normal to the axis is directly proportional to the distance from the centre of the axis, therefore the torsional shear stress at a distance x from the centre of the shaft is given by

$$\frac{\tau_x}{x} = \frac{\tau}{r}$$

2. From equation (i), we know that

$$\frac{T}{J} = \frac{\tau}{r} \quad \text{or} \quad T = \tau \times \frac{J}{r}$$

For a solid shaft of diameter (d), the polar moment of inertia,

$$J = I_{XX} + I_{YY} = \frac{\pi}{64} \times d^4 + \frac{\pi}{64} \times d^4 = \frac{\pi}{32} \times d^4$$

Therefore,

$$T = \tau \times \frac{\pi}{32} \times d^4 \times \frac{2}{d} = \frac{\pi}{16} \times \tau \times d^3$$

In case of a hollow shaft with external diameter (d_o) and internal diameter (d_i), the polar moment of inertia,

$$\begin{aligned}
 J &= \frac{\pi}{32} [(d_o)^4 - (d_i)^4] \text{ and } r = \frac{d_o}{2} \\
 T &= \tau \times \frac{\pi}{32} [(d_o)^4 - (d_i)^4] \times \frac{2}{d_o} = \frac{\pi}{16} \times \tau \left[\frac{(d_o)^4 - (d_i)^4}{d_o} \right] \\
 &= \frac{\pi}{16} \times \tau (d_o)^3 (1 - k^4) \quad \dots \left(\text{Substituting, } k = \frac{d_i}{d_o} \right)
 \end{aligned}$$

3. The expression ($C \times J$) is called **torsional rigidity** of the shaft.
4. The strength of the shaft means the maximum torque transmitted by it. Therefore, in order to design a shaft for strength, the above equations are used. The power transmitted by the shaft (in watts) is given by

$$P = \frac{2 \pi N \cdot T}{60} = T \cdot \omega \quad \dots \left(\because \omega = \frac{2 \pi N}{60} \right)$$

Where T = Torque transmitted in N-m, and

ω = Angular speed in rad/s.

Problem:

A shaft is transmitting 100 kW at 160 r.p.m. Find a suitable diameter for the shaft, if the maximum torque transmitted exceeds the mean by 25%. Take maximum allowable shear stress as 70 MPa.

Solution. Given : $P = 100 \text{ kW} = 100 \times 10^3 \text{ W}$; $N = 160 \text{ r.p.m}$; $T_{max} = 1.25 T_{mean}$; $\tau = 70 \text{ MPa} = 70 \text{ N/mm}^2$

Let T_{mean} = Mean torque transmitted by the shaft in N-m, and
 d = Diameter of the shaft in mm.

We know that the power transmitted (P),

$$100 \times 10^3 = \frac{2 \pi N \cdot T_{mean}}{60} = \frac{2\pi \times 160 \times T_{mean}}{60} = 16.76 T_{mean}$$

$$\therefore T_{mean} = 100 \times 10^3 / 16.76 = 5966.6 \text{ N-m}$$

and maximum torque transmitted,

$$T_{max} = 1.25 \times 5966.6 = 7458 \text{ N-m} = 7458 \times 10^3 \text{ N-mm}$$

We know that maximum torque (T_{max}),

$$7458 \times 10^3 = \frac{\pi}{16} \times \tau \times d^3 = \frac{\pi}{16} \times 70 \times d^3 = 13.75 d^3$$

$$\therefore d^3 = 7458 \times 10^3 / 13.75 = 542.4 \times 10^3 \text{ or } d = 81.5 \text{ mm Ans.}$$

Bending Stress

In engineering practice, the machine parts of structural members may be subjected to static or dynamic loads which cause bending stress in the sections besides other types of stresses such as tensile, compressive and shearing stresses. Consider a straight beam subjected to a bending moment M as shown in Fig.

The following assumptions are usually made while deriving the bending formula .

1. The material of the beam is perfectly homogeneous (*i.e.* of the same material throughout) and isotropic (*i.e.* of equal elastic properties in all directions).
2. The material of the beam obeys Hooke's law.
3. The transverse sections (*i.e.* BC or GH) which were plane before bending remain plane after bending also.
4. Each layer of the beam is free to expand or contract, independently, of the layer, above or below it.
5. The Young's modulus (E) is the same in tension and compression.
6. The loads are applied in the plane of bending.

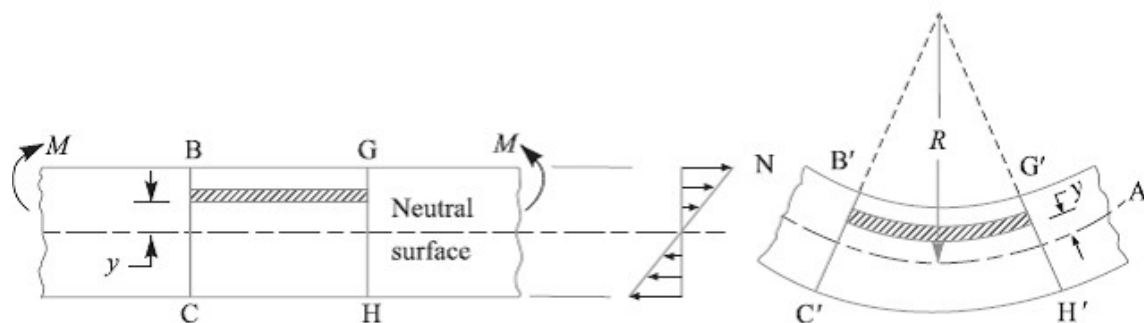

A little consideration will show that when a beam is subjected to the bending moment, the fibres on the upper side of the beam will be shortened due to compression and those on the lower side will be elongated due to tension. It may be seen that somewhere between the top and bottom fibres there is a surface at which the fibres are neither shortened nor lengthened. Such a surface is called **neutral surface**. The intersection of the neutral surface with any normal cross-section of the beam is known as **neutral axis**. The stress distribution of a beam is shown in Fig. The bending equation is given by

$$\frac{M}{I} = \frac{\sigma}{y} = \frac{E}{R}$$

Where M = Bending moment acting at the given

section, σ = Bending stress,

I = Moment of inertia of the cross-section about the neutral axis, y = Distance from the neutral axis to the extreme fibre,

E = Young's modulus of the material of the beam,

and R = Radius of curvature of the beam.

From the above equation, the bending stress is given by

$$\sigma = y \times \frac{E}{R}$$

Since E and R are constant, therefore within elastic limit, the stress at any point is directly proportional to y , i.e. the distance of the point from the neutral axis. Also from the above equation, the bending stress,

$$\sigma = \frac{M}{I} \times y = \frac{M}{I/y} = \frac{M}{Z}$$

The ratio I/y is known as **section modulus** and is denoted by Z .

Notes: 1. the neutral axis of a section always passes through its centroid.

2. In case of symmetrical sections such as circular, square or rectangular, the neutral axis passes through its geometrical centre and the distance of extreme fibre from the neutral axis

is $y = d/2$, where d is the diameter in case of circular section or depth in case of square or rectangular section.

3. In case of unsymmetrical sections such as L-section or T-section, the neutral axis does not pass through its geometrical centre. In such cases, first of all the centroid of the section is calculated and then the distance of the extreme fibres for both lower and upper side of the section is obtained. Out of these two values, the bigger value is used in bending equation.

Problem:

A beam of uniform rectangular cross-section is fixed at one end and carries an electric motor weighing 400 N at a distance of 300 mm from the fixed end. The maximum bending stress in the beam is 40 MPa. Find the width and depth of the beam, if depth is twice that of width.

Solution. Given: $W = 400 \text{ N}$; $L = 300 \text{ mm}$;
 $\sigma_b = 40 \text{ MPa} = 40 \text{ N/mm}^2$; $h = 2b$

The beam is shown in Fig. 5.7.

Let $b =$ Width of the beam in mm, and
 $h =$ Depth of the beam in mm.

\therefore Section modulus,

$$Z = \frac{b \cdot h^2}{6} = \frac{b (2b)^2}{6} = \frac{2 b^3}{3} \text{ mm}^3$$

Maximum bending moment (at the fixed end),

$$M = WL = 400 \times 300 = 120 \times 10^3 \text{ N-mm}$$

We know that bending stress (σ_b),

$$40 = \frac{M}{Z} = \frac{120 \times 10^3 \times 3}{2 b^3} = \frac{180 \times 10^3}{b^3}$$

$$\therefore b^3 = 180 \times 10^3 / 40 = 4.5 \times 10^3 \text{ or } b = 16.5 \text{ mm Ans.}$$

and

$$h = 2b = 2 \times 16.5 = 33 \text{ mm Ans.}$$

Problem:

A cast iron pulley transmits 10 kW at 400 r.p.m. The diameter of the pulley is 1.2 metre and it has four straight arms of elliptical cross-section, in which the major axis is twice the minor axis. Determine the dimensions of the arm if the allowable bending stress is 15 MPa.

Solution. Given : $P = 10 \text{ kW} = 10 \times 10^3 \text{ W}$; $N = 400 \text{ r.p.m}$; $D = 1.2 \text{ m} = 1200 \text{ mm}$ or $R = 600 \text{ mm}$; $\sigma_b = 15 \text{ MPa} = 15 \text{ N/mm}^2$

Let $T =$ Torque transmitted by the pulley.

We know that the power transmitted by the pulley (P),

Principal Stresses and Principal Planes

In the previous chapter, we have discussed about the direct tensile and compressive stress as well as simple shear. Also we have always referred the stress in a plane which is at right angles to the line of action of the force. But it has been observed that at any point in a strained material, there are three planes, mutually perpendicular to each other which carry direct stresses only and no shear stress. It may be noted that out of these three direct stresses, one will be maximum and the other will be minimum. These perpendicular planes which have no shear stress are known as *principal planes* and the direct stresses along these planes are known as *principal stresses*. The planes on which the maximum shear stress act are known as planes of maximum shear.

Determination of Principal Stresses for a Member Subjected to Bi-axial Stress

When a member is subjected to bi-axial stress (*i.e.* direct stress in two mutually perpendicular planes accompanied by a simple shear stress), then the normal and shear stresses are obtained as discussed below:

Consider a rectangular body $ABCD$ of uniform cross-sectional area and unit thickness subjected to normal stresses σ_1 and σ_2 as shown in Fig. (a). In addition to these normal stresses, a shear stress τ and τ (ϕ) respectively, Mathematically, also acts. It has been shown in books on '*Strength of Materials*' that the normal stress across any oblique section such as EF inclined at an angle θ with the direction of σ_2 , as shown in Fig. (a), is given by

$$\sigma_r = \frac{\sigma_1 + \sigma_2}{2} + \frac{\sigma_1 - \sigma_2}{2} \cos 2\theta + \tau \sin 2\theta \quad \dots(i)$$

And tangential stress (*i.e.* shear stress) across the section EF ,

$$\tau_1 = \frac{1}{2} (\sigma_1 - \sigma_2) \sin 2\theta - \tau \cos 2\theta \quad \dots(ii)$$

Since the planes of maximum and minimum normal stress (*i.e.* principal planes) have no shear stress, therefore the inclination of principal planes is obtained by equating τ_1 and τ_2 respectively, Mathematically, $\tau_1 = 0$ in the above equation (ii), *i.e.*

$$\begin{aligned} \frac{1}{2} (\sigma_1 - \sigma_2) \sin 2\theta - \tau \cos 2\theta &= 0 \\ \tan 2\theta &= \frac{2\tau}{\sigma_1 - \sigma_2} \quad \dots(iii) \end{aligned}$$

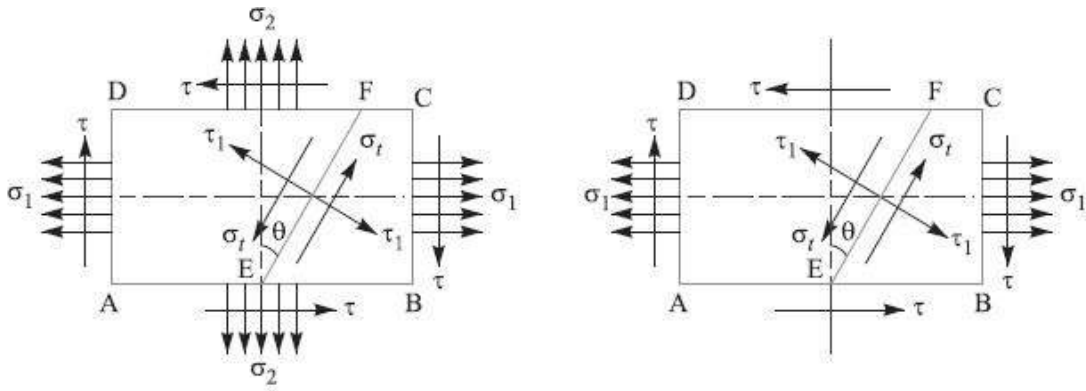

(a) Direct stress in two mutually perpendicular planes accompanied by a simple shear stress. (b) Direct stress in one plane accompanied by a simple shear stress.

We know that there are two principal planes at right angles to each other. Let θ_1 and θ_2 be the inclinations of these planes with the normal cross-section. From the following Fig., we find that

$$\sin 2\theta = \pm \frac{2\tau}{\sqrt{(\sigma_1 - \sigma_2)^2 + 4\tau^2}}$$

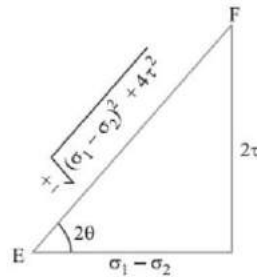

$$\therefore \sin 2\theta_1 = + \frac{2\tau}{\sqrt{(\sigma_1 - \sigma_2)^2 + 4\tau^2}}$$

and
$$\sin 2\theta_2 = - \frac{2\tau}{\sqrt{(\sigma_1 - \sigma_2)^2 + 4\tau^2}}$$

Also
$$\cos 2\theta = \pm \frac{\sigma_1 - \sigma_2}{\sqrt{(\sigma_1 - \sigma_2)^2 + 4\tau^2}}$$

$$\therefore \cos 2\theta_1 = + \frac{\sigma_1 - \sigma_2}{\sqrt{(\sigma_1 - \sigma_2)^2 + 4\tau^2}}$$

and
$$\cos 2\theta_2 = - \frac{\sigma_1 - \sigma_2}{\sqrt{(\sigma_1 - \sigma_2)^2 + 4\tau^2}}$$

The maximum and minimum principal stresses may now be obtained by substituting the values of $\sin 2\theta$ and $\cos 2\theta$ in equation (i).

So, Maximum principal (or normal) stress,

$$\sigma_{r1} = \frac{\sigma_1 + \sigma_2}{2} + \frac{1}{2} \sqrt{(\sigma_1 - \sigma_2)^2 + 4\tau^2} \quad \dots(iv)$$

And minimum principal (or normal) stress,

$$\sigma_{r2} = \frac{\sigma_1 + \sigma_2}{2} - \frac{1}{2} \sqrt{(\sigma_1 - \sigma_2)^2 + 4\tau^2} \quad \dots(v)$$

The planes of maximum shear stress are at right angles to each other and are inclined at 45° to the principal planes. The maximum shear stress is given by **one-half the algebraic difference between the principal stresses**, i.e.

$$\tau_{max} = \frac{\sigma_1 - \sigma_2}{2} = \frac{1}{2} \sqrt{(\sigma_1 - \sigma_2)^2 + 4\tau^2} \quad \dots(vi)$$

Notes: 1. when a member is subjected to direct stress in one plane accompanied by a simple shear stress, then the principal stresses are obtained by substituting $\theta_2 = 0$ in equation (iv), (v) and (vi).

$$\begin{aligned} \sigma_{r1} &= \frac{\sigma_1}{2} + \frac{1}{2} \left[\sqrt{(\sigma_1)^2 + 4\tau^2} \right] \\ \sigma_{r2} &= \frac{\sigma_1}{2} - \frac{1}{2} \left[\sqrt{(\sigma_1)^2 + 4\tau^2} \right] \\ \tau_{max} &= \frac{1}{2} \left[\sqrt{(\sigma_1)^2 + 4\tau^2} \right] \end{aligned}$$

2. In the above expression of σ_{r2} , the value of $\frac{1}{2} \left[\sqrt{(\sigma_1)^2 + 4\tau^2} \right]$ is more than $\sigma_1/2$. Therefore the nature of σ_{r2} will be opposite to that of σ_{r1} , i.e. if σ_{r1} is tensile then σ_{r2} will be compressive and *vice-versa*.

Application of Principal Stresses in Designing Machine Members

There are many cases in practice, in which machine members are subjected to combined stresses due to simultaneous action of either tensile or compressive stresses combined with shear stresses. In many shafts such as propeller shafts, C-frames etc., there are direct tensile or compressive stresses due to the external force and shear stress due to torsion, which acts

normal to direct tensile or compressive stresses. The shafts like crank shafts, are subjected simultaneously to torsion and bending. In such cases, the maximum principal stresses, due to the combination of tensile or compressive stresses with shear stresses may be obtained. The results obtained in the previous article may be written as follows:

1. Maximum tensile stress,

$$\sigma_{t(max)} = \frac{\sigma_t}{2} + \frac{1}{2} \left[\sqrt{(\sigma_t)^2 + 4\tau^2} \right]$$

2. Maximum compressive stress,

$$\sigma_{c(max)} = \frac{\sigma_c}{2} + \frac{1}{2} \left[\sqrt{(\sigma_c)^2 + 4\tau^2} \right]$$

3. Maximum shear stress,

$$\tau_{max} = \frac{1}{2} \left[\sqrt{(\sigma_t)^2 + 4\tau^2} \right]$$

Where σ_t = Tensile stress due to direct load and

bending, σ_c = Compressive stress, and

τ respectively, Mathematically, = Shear stress due to torsion.

Notes: 1. When τ respectively, Mathematically, = 0 as in the case of thin cylindrical shell subjected in internal fluid pressure, then $\sigma_{t(max)} = \sigma_t$

2. When the shaft is subjected to an axial load (P) in addition to bending and twisting moments as in the propeller shafts of ship and shafts for driving worm gears, then the stress due to axial load must be added to the bending stress (σ_b). This will give the resultant tensile stress or compressive stress (σ_t or σ_c) depending upon the type of axial load (*i.e.* pull or push).

Problem:

A shaft, as shown in Fig., is subjected to a bending load of 3 kN, pure torque of 1000 N-m and an axial pulling force of 15 kN. Calculate the stresses at A and B.

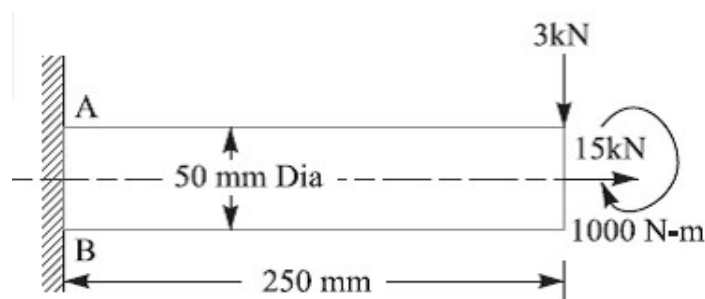

Stresses at point A

We know that maximum principal (or normal) stress at point A,

$$\begin{aligned}\sigma_{A(max)} &= \frac{\sigma_A}{2} + \frac{1}{2} \left[\sqrt{(\sigma_A)^2 + 4 \tau^2} \right] \\ &= \frac{68.74}{2} + \frac{1}{2} \left[\sqrt{(68.74)^2 + 4 (40.74)^2} \right] \\ &= 34.37 + 53.3 = 87.67 \text{ MPa (tensile) Ans.}\end{aligned}$$

Minimum principal (or normal) stress at point A,

$$\begin{aligned}\sigma_{A(min)} &= \frac{\sigma_A}{2} - \frac{1}{2} \left[\sqrt{(\sigma_A)^2 + 4 \tau^2} \right] = 34.37 - 53.3 = -18.93 \text{ MPa} \\ &= 18.93 \text{ MPa (compressive) Ans.}\end{aligned}$$

and maximum shear stress at point A,

$$\begin{aligned}\tau_{A(max)} &= \frac{1}{2} \left[\sqrt{(\sigma_A)^2 + 4 \tau^2} \right] = \frac{1}{2} \left[\sqrt{(68.74)^2 + 4 (40.74)^2} \right] \\ &= 53.3 \text{ MPa Ans.}\end{aligned}$$

Stresses at point B

We know that maximum principal (or normal) stress at point B,

$$\begin{aligned}\sigma_{B(max)} &= \frac{\sigma_B}{2} + \frac{1}{2} \left[\sqrt{(\sigma_B)^2 + 4 \tau^2} \right] \\ &= \frac{53.46}{2} + \frac{1}{2} \left[\sqrt{(53.46)^2 + 4 (40.74)^2} \right] \\ &= 26.73 + 48.73 = 75.46 \text{ MPa (compressive) Ans.}\end{aligned}$$

Minimum principal (or normal) stress at point B,

$$\begin{aligned}\sigma_{B(min)} &= \frac{\sigma_B}{2} - \frac{1}{2} \left[\sqrt{(\sigma_B)^2 + 4 \tau^2} \right] \\ &= 26.73 - 48.73 = -22 \text{ MPa} \\ &= 22 \text{ MPa (tensile) Ans.}\end{aligned}$$

and maximum shear stress at point B,

$$\begin{aligned}\tau_{B(max)} &= \frac{1}{2} \left[\sqrt{(\sigma_B)^2 + 4 \tau^2} \right] = \frac{1}{2} \left[\sqrt{(53.46)^2 + 4 (40.74)^2} \right] \\ &= 48.73 \text{ MPa Ans.}\end{aligned}$$

Factor of Safety

It is defined, in general, as the **ratio of the maximum stress to the working stress**.
Mathematically,

$$\text{Factor of safety} = \text{Maximum stress} / \text{Working or design stress}$$

In case of ductile materials e.g. mild steel, where the yield point is clearly defined, the factor of safety is based upon the yield point stress. In such cases,

$$\text{Factor of safety} = \text{Yield point stress} / \text{Working or design stress}$$

In case of brittle materials *e.g.* cast iron, the yield point is not well defined as for ductile materials. Therefore, the factor of safety for brittle materials is based on ultimate stress.

Factor of safety = Ultimate stress/ Working or design stress
This relation may also be used for ductile materials.

The above relations for factor of safety are for static loading.

Design for strength and rigidity:

Design for strength:

All the concepts discussed so far and the problems done are strength based, i.e., there will be some permissible stress or strength and our task is to limit the stresses below the given permissible value and accordingly sizing the machine element.

Design for rigidity or stiffness:

It is the ability to resist deformations under the action of external load. Along with strength, rigidity is also a very important operating property of many machine components. Ex: helical and leaf springs, elastic elements in various instruments, shafts, bearings, toothed and worm gears and so on.

In many cases, this parameter of operating capacity proves to be most important and to ensure it the dimensions of the part have to be increased to such an extent that the actual induced stresses become much lower than the allowable ones. Rigidity is also necessary to ensure that the mated parts and the machine as a whole operate effectively.

Forces subject the parts to elastic deformations: shafts are bent and twisted, bolts are stretched etc.,

1. When a shaft is deflected, its journals are misaligned in the bearings thereby causing the uneven wear of the shells, heating and seizure in the sliding bearings.
2. Deflections and angles of turn of shafts at the places where gears are fitted cause non-uniform load distribution over the length of the teeth.
3. With the deflection of an insufficiently rigid shaft, the operating conditions or antifriction bearings sharply deteriorate if the bearings cannot self-aligning.
4. Rigidity is particularly important for ensuring the adequate accuracy of items produced on machine tools.

Rigidity of machine elements is found with the help of formulae from the theory of strength of materials. The actual displacements like deflections, angles of turn, angles of twist should not be more than the allowable values. The most important design methods for increasing the rigidity of machine elements are as follows.

- a) The decrease in the arms of bending and twisting forces.
- b) The incorporation of additional supports.
- c) The application of cross sections which effectively resist torsion (closed tubular) and bending (in which the cross section is removed as far as possible from the neutral axis).

d) The decrease of the length of the parts in tension and the increase of their cross section area.

From the above it's clear that the stiffness of a member depends not only on the shape and size of its cross section but also on elastic modulus of the material used.

Preferred Numbers

When a machine is to be made in several sizes with different powers or capacities, it is necessary to decide what capacities will cover a certain range efficiently with minimum number of sizes. It has been shown by experience that a certain range can be covered efficiently when it follows a geometrical progression with a constant ratio. The preferred numbers are the conventionally rounded off values derived from geometric series including the integral powers of 10 and having as common ratio of the following factors:

$$^5\sqrt{10}, ^{10}\sqrt{10}, ^{20}\sqrt{10}, ^{40}\sqrt{10}$$

These ratios are approximately equal to 1.58, 1.26, 1.12 and 1.06. The series of preferred numbers are designated as *R5, R10, R20 and R40 respectively. These four series are called *basic series*. The other series called *derived series* may be obtained by simply multiplying or dividing the basic sizes by 10, 100, etc. The preferred numbers in the series R5 are 1, 1.6, 2.5, 4.0 and 6.3

The concept of stiffness in tension, bending, torsion, and combined situations

Stiffness in tension:



$$\frac{F}{A} = \frac{F}{\frac{4d^2}{E}}$$

δl may be a constraint or δA may be a constraint

Stiffness in Bending:

δ, d, θ may be constraints

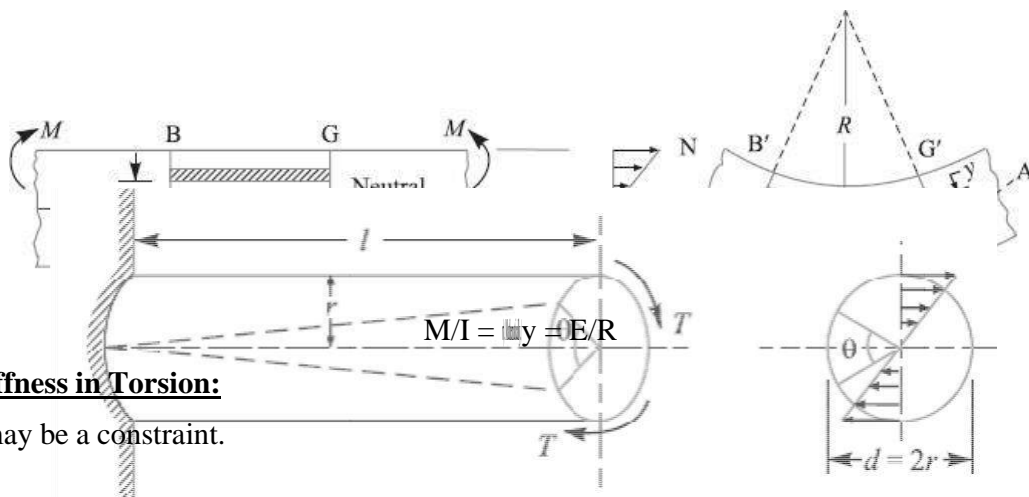

Stiffness in Torsion:

θ may be a constraint.

$$T/J = \frac{r}{G} = G\theta/l$$

Combined situations:

σ_1 , σ_2 , and τ_{max} any one or two may be constraints. Then control the elements of the formulae like σ , τ and ϕ respectively, by adjusting the geometry of the machine element or changing the type of material used which changes E.

$$\sigma_{r1} = \frac{\sigma_1 + \sigma_2}{2} + \frac{1}{2} \sqrt{(\sigma_1 - \sigma_2)^2 + 4 \tau^2}$$

$$\sigma_{r2} = \frac{\sigma_1 + \sigma_2}{2} - \frac{1}{2} \sqrt{(\sigma_1 - \sigma_2)^2 + 4 \tau^2}$$

$$\tau_{max} = \frac{\sigma_1 - \sigma_2}{2} = \frac{1}{2} \sqrt{(\sigma_1 - \sigma_2)^2 + 4 \tau^2}$$

Fracture Toughness

Fracture toughness is an indication of the amount of stress required to propagate a preexisting flaw. It is a very important material property since the occurrence of flaws is not completely avoidable in the processing, fabrication, or service of a material/component. Flaws may appear as cracks, voids,

metallurgical inclusions, weld defects, design discontinuities, or some combination thereof. Since engineers can never be totally sure that a material is flaw free, it is common practice to assume that a flaw of some chosen size will be present in some number of components and use the linear elastic fracture mechanics (LEFM) approach to design critical components. This approach uses the flaw size and features, component geometry, loading conditions and the material property called fracture toughness to evaluate the ability of a component containing a flaw to resist fracture.

A parameter called the stress-intensity factor (K) is used to determine the fracture toughness of most materials. A Roman

numeral subscript indicates the mode of fracture and the three modes of fracture are illustrated in the image to the right. Mode I fracture is the condition in which the crack plane is normal to the direction of largest tensile loading. This is the most commonly encountered mode and, therefore, for the remainder of the material we will consider K_I

The stress intensity factor is a function of loading, crack size, and structural geometry. The stress intensity factor may be represented by the following equation:

$$K_I = \sigma \sqrt{\pi a \beta}$$

Where: K_I is the fracture toughness in $MPa\sqrt{m}$ ($psi\sqrt{in}$)

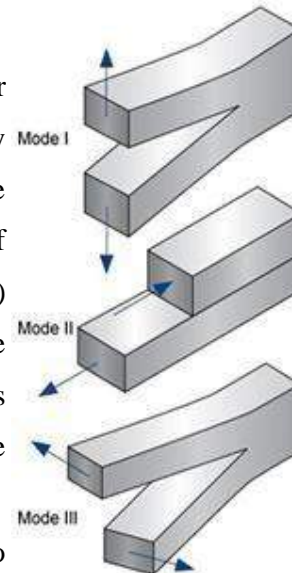

σ is the applied stress in MPa or psi
 a is the crack length in meters or inches
 β is a crack length and component geometry factor that is different for each specimen and is dimensionless.

References:

0. Machine Design - V.Bandari
1. Machine Design – R.S. Khurmi
2. Design Data hand Book - S MD Jalaludin..