

WIND AND TYPES OF WIND GENERATORS

UNIT 3

WIND AND TYPES OF WIND GENERATORS

- **Introduction to wind:**
 - Characteristics,
 - Wind Turbine, Fixed and Variable-Speed Wind Turbines,
 - Components of WECS, Description of Components,
 - **Types of Wind Turbine Generators,**
 - Economics of Wind Energy Conversion Systems,
 - Linking Wind Turbines onto the Grid,
 - Power Converter Topologies for Wind Turbine Generators.
-
- <https://www.slideshare.net/slideshow/grid-integration-of-the-wt-gs/38689343>
 - <https://www.youtube.com/watch?v=65sHm-2ZNFU>

Introduction to wind:

- Wind is the movement of air caused by uneven solar heating of the Earth, creating differences in atmospheric pressure.
- It's a natural phenomenon that moves horizontally from **high-pressure** to **low-pressure areas**, with scales ranging from local breezes to global patterns.
- Wind cannot be seen but is felt and can shape landscapes, influence weather, and be harnessed to generate sustainable electricity.

What is Wind?

- Wind is air in motion, possessing both speed and direction.
- It's a visible but intangible force (an influence, power, or asset that cannot be physically touched or seen but can be felt or observed through its effects), manifested by its effects on objects like trees, sand, and leaves.

How Wind Forms

- **Uneven Heating:**

- The Sun heats the Earth's surface unevenly, warming air more in some areas (like the equator) and less in others.

- **Pressure Differences:**

- Warmer, less dense air rises, creating low-pressure areas, while cooler, denser air sinks, creating high-pressure areas.

- **Air Movement:**

- Winds are created as air moves from these high-pressure regions to the low-pressure regions to balance the pressure difference.

Characteristics

Measurement:

Wind direction and speed are measured using instruments like a weathercock (or weather vane).

Scale:

Wind occurs on various scales, from local, short-lived breezes to large-scale global wind systems.

Renewable Energy:

Wind energy is a significant source of renewable electricity, with wind turbines designed to convert wind's kinetic energy into power.

Environmental Role:

Winds play a crucial role in the global transport of heat, moisture, and even pollutants, acting as a "great equalizer" in the atmosphere.

It is the conversion of wind energy into a useful form of energy, such as using wind turbines to make electrical power, windmills for mechanical power, windpumps for water pumping.



Operating Characteristics of wind mills:

All wind machines share certain operating characteristics, such as cut-in, rated and cutout wind speeds.

1. Cut-in Speed: Cut-in speed is the minimum wind speed at which the blades will turn and generate usable power. This wind speed is typically between 10 and 16 kmph.

2. Rated Speed:

The rated speed is the minimum wind speed at which the wind turbine will generate its designated rated power.

For example, a "10 kilowatt" wind turbine may not generate 10kilowatts until wind speeds reach 40 kmph. Rated speed for most machines is in the range of 40 to 55 kmph.

At wind speeds between cut-in and rated, the power output from a wind turbine increases as the wind increases.

The output of most machine's levels off above the rated speed. Most manufacturers provide graphs, called "power curves, "showing how their wind turbine output varies with wind speed.

3.Cut-out Speed:

At very high wind speeds, typically between 72 and 128 kmph, most wind turbines cease power generation and shut down.

The wind speed at which shut down occurs is called the cut- out speed. Having a cut-out speed is a safety feature which protects the wind turbine from damage.

Shut down may occur in one of several ways.

In some machines an automatic brake is activated by a wind speed sensor.

Some machines twist or "pitch" the blades to spill the wind.

Still others use "spoilers," drag flaps mounted on the blades or the hub which are automatically activated by high rotor rpms, or mechanically activated by a spring-loaded device which turns the machine sideways to the wind stream.

Normal wind turbine operation usually resumes when the wind drops back to a safe level.

3. Betz Limit:

- It is the flow of air over the blades and through the rotor area that makes a wind turbine function.
- The wind turbine extracts energy by slowing the wind down.
- The theoretical maximum amount of energy in the wind that can be collected by a wind turbine's rotor is approximately 59%. This value is known as the Betz limit.
- If the blades were 100% efficient, a wind turbine would not work because the air, having given up all its energy, would entirely stop.
- In practice, the collection efficiency of a rotor is not as high as 59%.
- A more typical efficiency is 35% to 45%.
- A complete wind energy system, including rotor, transmission, generator, storage and other devices, which all have less than perfect efficiencies, will deliver between 10% and 30% of the original energy available in the wind.

Wind Turbine

Fixed and Variable-
Speed Wind Turbines,

FIXED SPEED WIND TURBINES

- Fixed-speed wind turbines operate at a constant rotor speed, regardless of wind conditions, and are typically connected directly to the grid.
- Variable-speed wind turbines, on the other hand, can adjust their rotor speed to match the wind speed, allowing them to capture more power and operate efficiently across a wider range of wind conditions.
- In **fixed speed wind turbine**, wind turbine speed is fixed independent of wind speed
- Rotor speed of wind turbine is fixed by gear ratio, supply frequency and generator design
- Fixed speed wind turbines are coupled with induction generators which is connected to grid directly through a soft starter and capacitor bank Design of such type of wind turbine is done to achieve maximum efficiency at any one 27.35 CC particular speed of wind

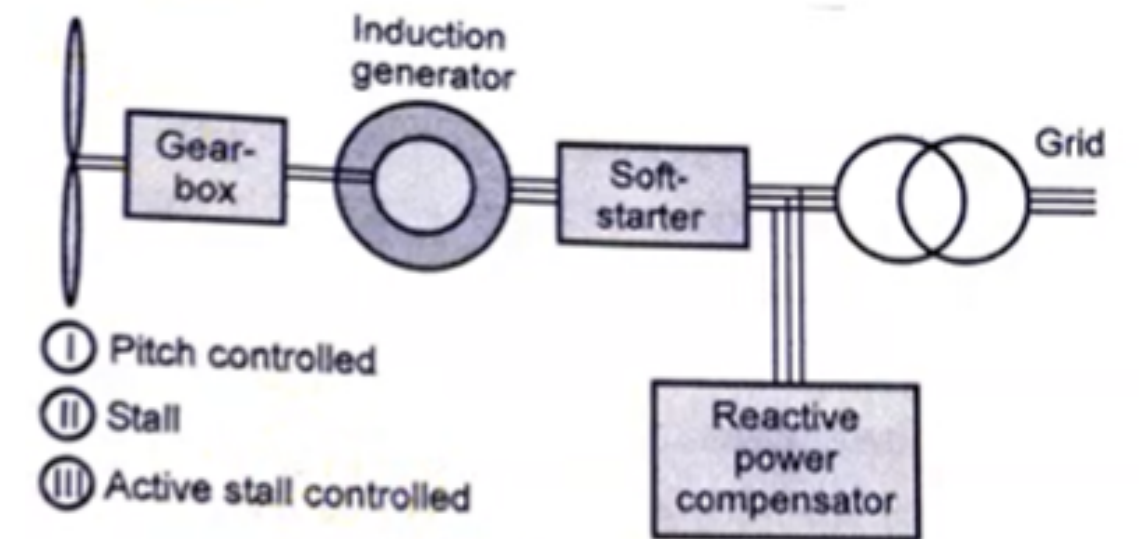

soft-starter is to create electrical isolation between the wind turbine system and the grid for a very short time to limit the starting high inrush current of the induction generator during the transient period.

- Fixed -speed wind turbine power production can be increased by using two winding sets for generator
- One set is used for low wind speed (typically 8 poles) and other set is used at medium or high wind speed (typically 4 poles)
- Since the turbine operates at fixed speed, fluctuation in wind speed is transmitted as fluctuation in mechanical torque and thereafter as fluctuation in electrical power into the grid
- For weak grids, this power fluctuation creates large voltage variation and significant line loss
- In fixed speed wind turbines, power is limited aerodynamically by means of either stall control, active stall control or pitch control
- Soft start is used for reduction of inrush current and there by to limit flicker problem on the grid
- Reactive compensator is required in such turbines to reduce/almost to eliminate reactive power consumption from the turbine generator
- This is achieved by continuously switching capacitor banks.

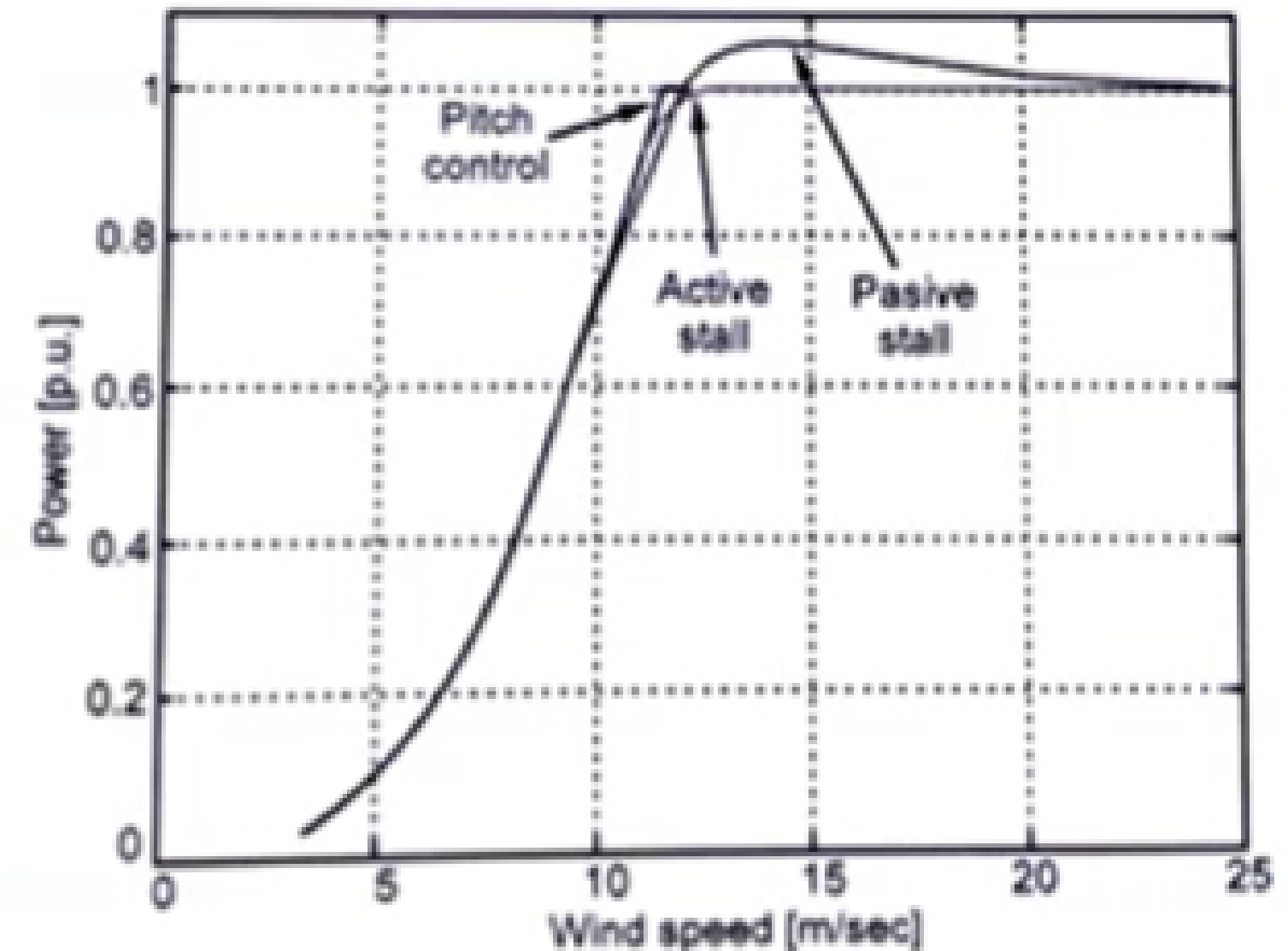

Stall control in a wind turbine involves deliberately causing airflow over the blades to separate at high wind speeds, increasing drag and reducing lift to limit the turbine's power output and rotational speed. This method relies on the blades' aerodynamic design and can be passive (fixed blades) or active (using actuators) to protect the turbine from excessive wind forces and maintain stable operation.

- **Advantages of fixed speed wind turbine**

- Design of fixed speed wind turbine is simple and robust
- This type of wind turbine is more reliable
- Cost of electronics elements used in this turbine is less

- **Disadvantages of fixed speed wind turbine**

- Reactive power consumption is more
- It creates more mechanical stress on the turbine
- Due to fixed speed operation large voltage fluctuations are produced to wand speed fluctuation

VARIABLE SPEED WIND TURBINES

- With change in wind speed, which is a natural occurrence, it is desirable for the turbine speed to be adjustable to the wind speed in order to maximize the output for this, it is required to have variable-speed operation of wind turbines along with suitable Electrical Power Generation systems i.e. suitable Generators
- This variable turbine speed operation is possible with **pitch angle control**
- Besides increased output, variable-speed turbine operation has many other advantages, in contrast to the constant-speed operation of generators in conventional power generating stations
- But this operation requires additional Power electronics devices to convert the variable voltage and variable frequency output that comes from the Electrical generators which cannot be connected to the Grid directly.
- Design of variable speed wind turbines is done to attain maximum aerodynamic efficiency for the wind ranges of wind speeds
- Due to the variable speed operation, rotational speed of the wind turbine ω can be adapted to the wind speed v
- It means that variation in wind speed can be adopted by rotor of wind turbine or rotational speed of wind turbine is accelerated or decelerated as per speed of wind.
- Tip speed ratio, λ is kept constant at a predefined value, which corresponds to maximum power coefficient.
- In contrast to fixed-speed wind turbines, variable speed wind turbines maintain the generator torque fairly constant and fluctuations in wind speed are absorbed by the variation in the speed of generator
- As compared to fixed speed wind turbines, variable speed wind turbines have a complicated electrical system. In variable speed systems, generators are not directly connected to grid but connected through power converters
- Advantage of power converters, connected to the grid is active and reactive power control is fast
- Generator speed is controlled by power converters. Power fluctuations created due to wind speed variations, are absorbed by means of changes in rotor generator speed and consequently in wind turbine rotor speed

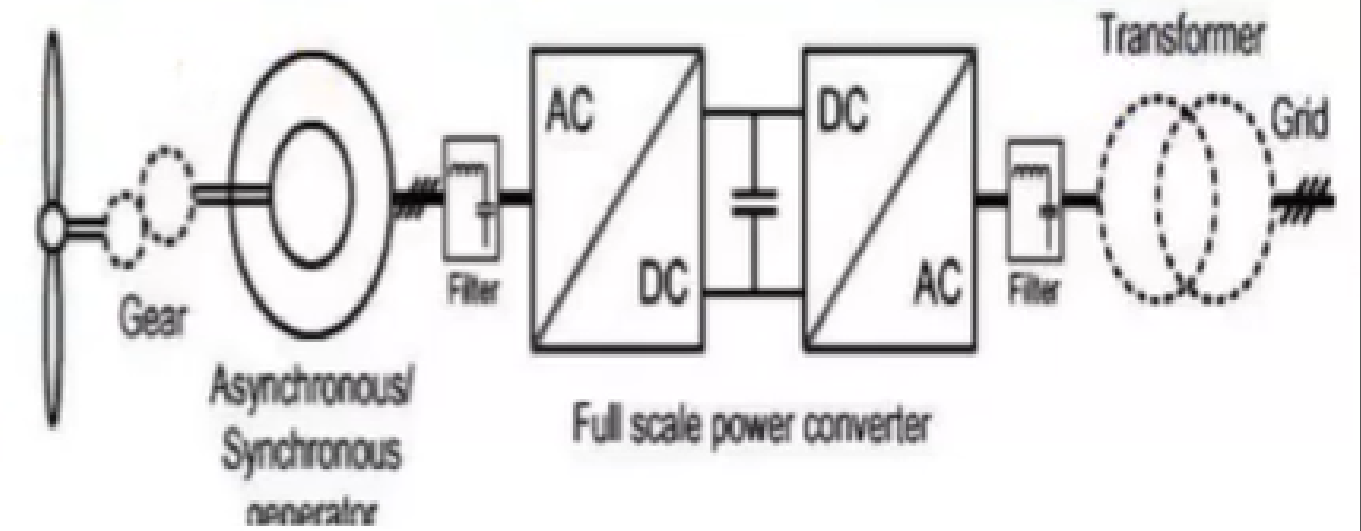

The Tip Speed Ratio (TSR) of a wind turbine is the ratio of the speed of the blade tips to the speed of the incoming wind

$$TSR = (\text{Blade Tip Speed}) / (\text{Wind Speed})$$

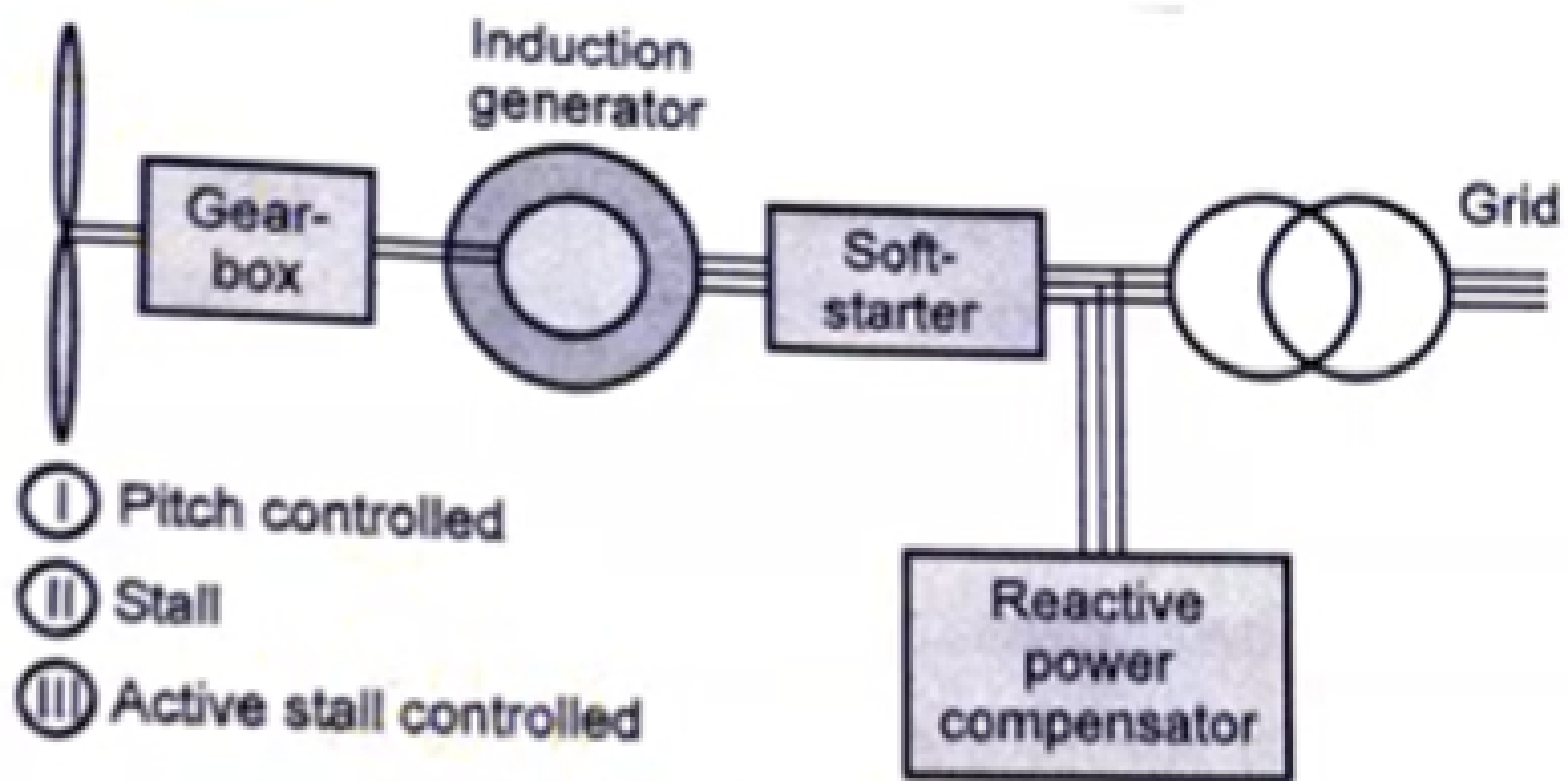

soft-starter is to create electrical isolation between the wind turbine system and the grid for a very short time to limit the starting high inrush current of the induction generator during the transient period.

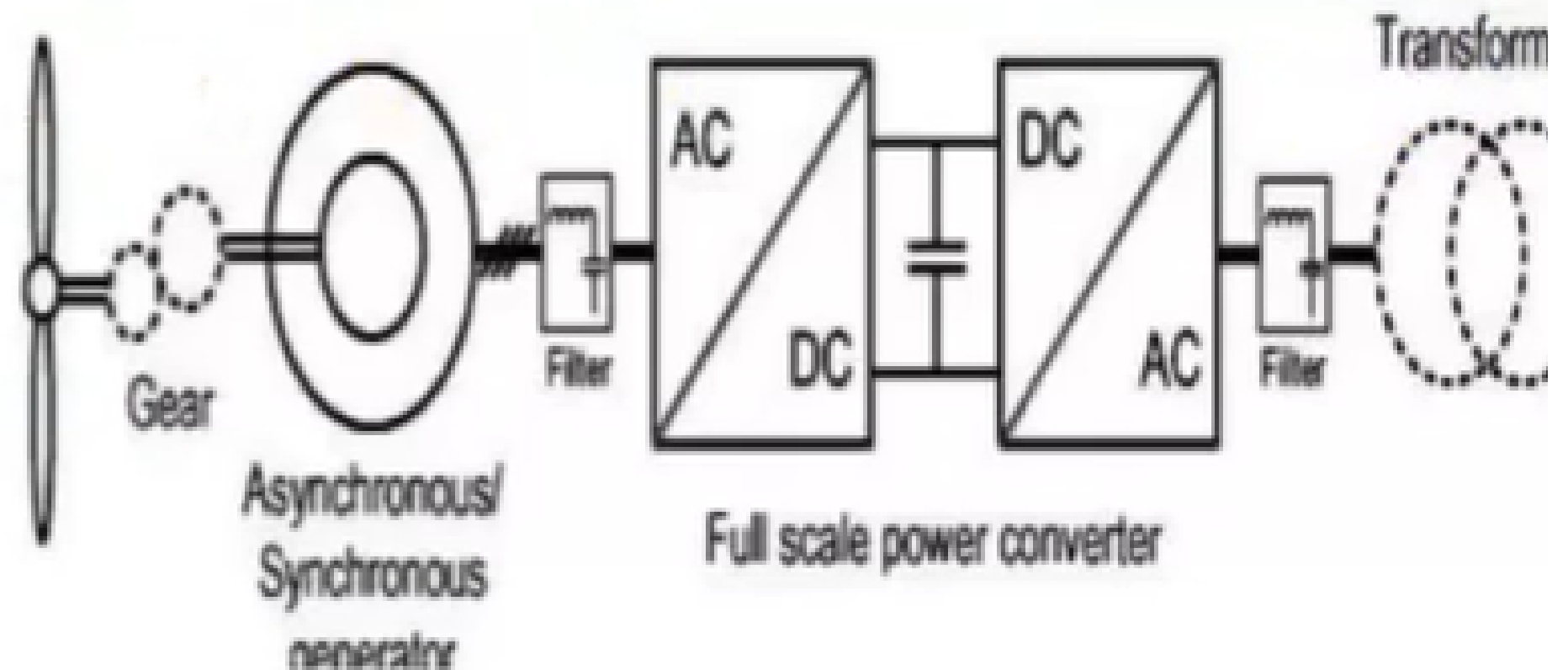

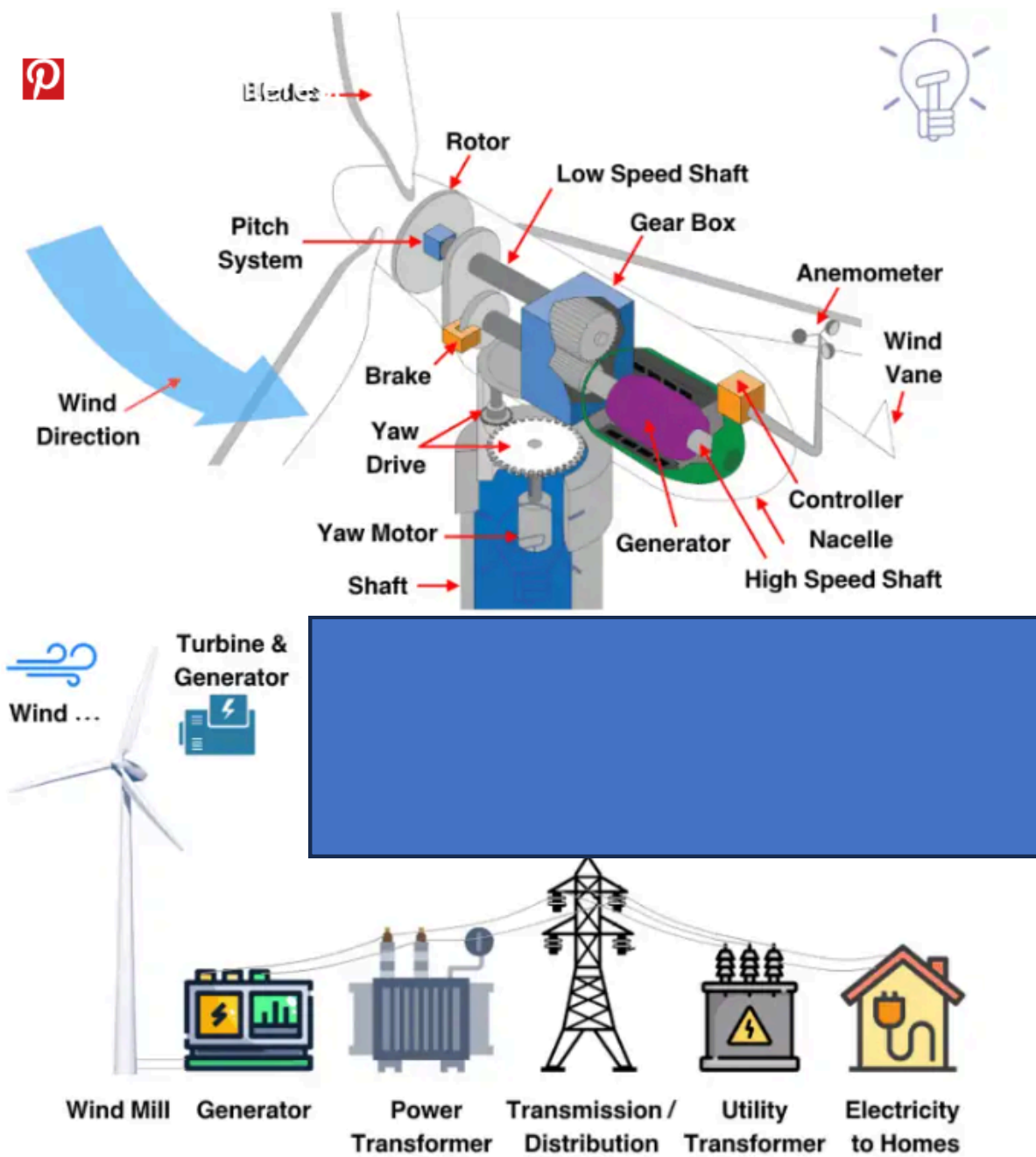

Classification of Wind Turbine:

According to the orientation of the axis of the rotor, wind turbines are classified into two types;

- Horizontal axis
- Vertical axis

Horizontal axis turbines :

In a horizontal axis turbine, the orientation of the axis is kept along the horizontal axis.
are classified into two types;

- **Propeller type**

- a propeller-type turbine, a number of blades are three or less than three.
- The propeller-type wind turbines are mounted on top of the tower and the blade of this turbine is made up of an airfoil or aerofoil section.
- Two-blade turbines are the most cost-effective turbine. But in this condition, a yaw control system is required to mitigate vibration. This configuration is used for large units (2 MW to 3 MW) with suitable material and control systems.
- A three-blade design is the most used and preferable design. Because the rotor is naturally balanced with a three-blade design. This configuration is used for a wide range of power generation (15 kW – 3 MW)

- **Multiblade type**

- a multiblade turbine, a greater number of blades are used.
- Multiblade turbines are used 12 to 20 blades made up of glass fiber reinforced plastic. The diameter of the multi-blade rotor varies from 2 m to 5 m. The multiblade turbine consists of curved sheet metal blades with inner and outer ends fixed with rims.

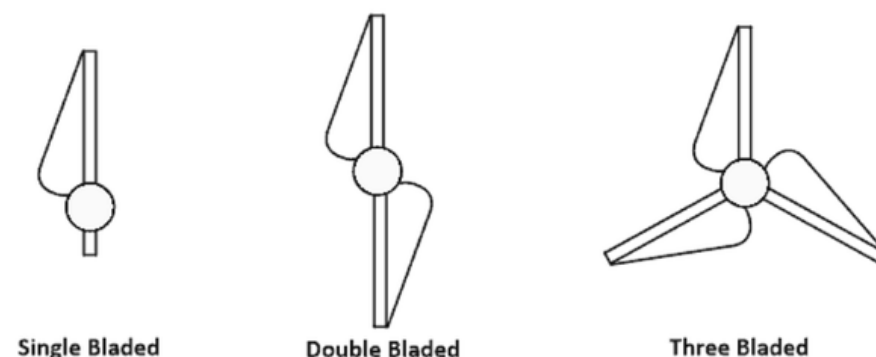

Fig. 1 – Propeller Wind Turbine

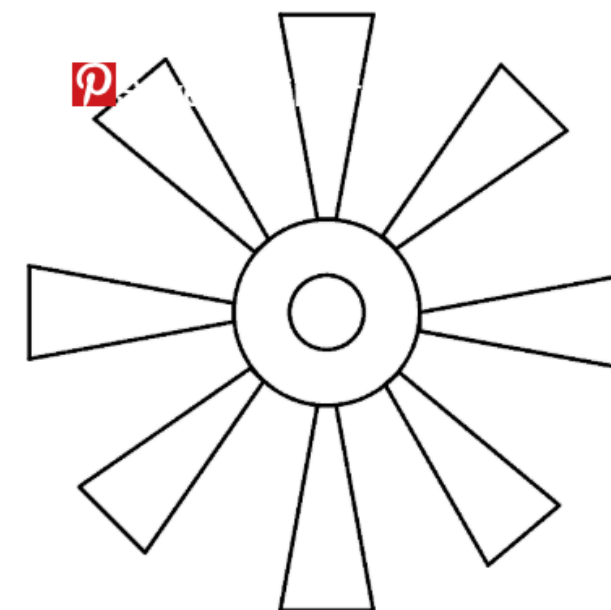

Fig. 2 – Multiblade Wind Turbine

Vertical Axis: In this type of wind turbine, the main rotor shaft is placed to transverse the wind and other accessories are placed at the base of the turbine.

- **Savonius type**

- In savonius type wind turbine, a hollow elliptical cylinder is placed into two pieces.
- And each piece makes half of the vertical turbine fixed to a vertical axis.
- The shape of this rotor looks like the alphabet 'S'.
- Therefore, savonius type rotor is also known as the S-type rotor.

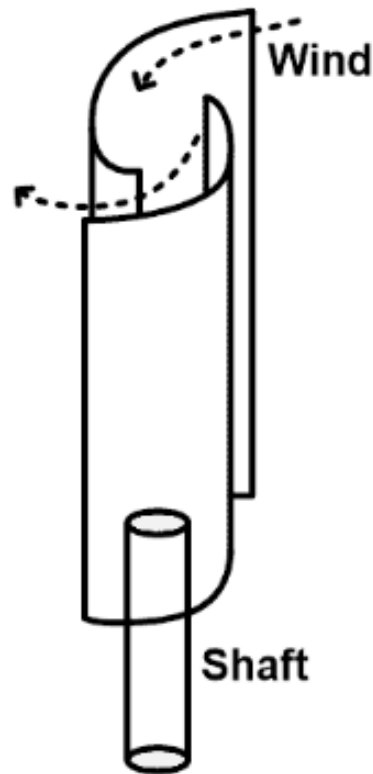

Fig. 3 – Savonius type wind turbine

- **Darrieus type**

- In darrieus type wind turbine, it consists of two or three blades.
- These blades are curved in shape and the shape of this blade is known as troposkein.
- The blades with aerofoil or airfoil cross-section are placed symmetrically on a vertical shaft.

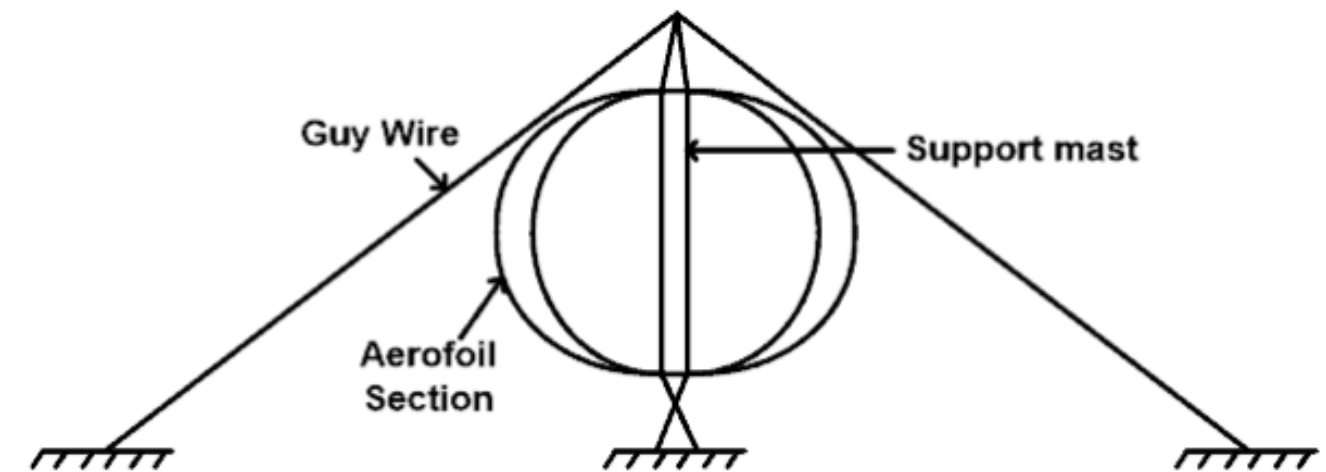

Fig. 4 – Darrieus type wind turbine

SPEED AND POWER RELATIONS

- The kinetic energy in air of mass m moving with speed V is given by the following in joules:
- The power in moving air is the $\text{kinetic energy} = \frac{1}{2}mV^2$: energy per second in watts:

If P = mechanical power in the moving air (watts) $\text{power} = \frac{1}{2}(\text{mass flow per second})V^2$

ρ = air density (kg/m³),

A = area swept by the rotor blades (m²), and

V = velocity of the air (m/sec),

then the volumetric flow rate is AV ,

the mass flow rate of the air in kilograms per second is ρAV ,

and the mechanical power coming in the upstream wind is given by the following in watts:

$$P = \frac{1}{2}(\rho AV)V^2 = \frac{1}{2}\rho AV^3$$

- Two potential wind sites are compared in terms of the specific wind power expressed in watts per square meter of area swept by the rotating blades.
- It is also referred to as the power density of the site, and is given by the following expression in watts per square meter of the rotor-swept area:

$$\text{specific power of the site} = \frac{1}{2} \rho V^3$$

This is the power in the upstream wind.

It varies linearly with the density of the air sweeping the blades and with the cube of the wind speed.

The blades cannot extract all of the upstream wind power, as some power is left in the downstream air that continues to move with reduced speed.

The actual power extracted by the rotor blades is the difference between the upstream and downstream wind powers. Using Equation 3.2, this is given by the following equation in units of watts:

$$P_o = \frac{1}{2} (\text{mass flow per second}) \{V^2 - V_o^2\}$$

$$P_o = \frac{1}{2}(\text{mass flow per second})\{V^2 - V_o^2\}$$

where P_o = mechanical power extracted by the rotor, i.e., the turbine output power,
 V = upstream wind velocity at the entrance of the rotor blades,
and V_o = downstream wind velocity at the exit of the rotor blades.

Multiplying the air density by the average velocity, therefore, gives the mass flow rate of air through the rotating blades, which is as follows:

The mechanical power extracted therefore: $\text{mass flow rate} = \rho A \frac{V + V_o}{2}$ drives the electrical generator, is

$$P_o = \frac{1}{2} \left[\rho A \frac{(V + V_o)}{2} \right] (V^2 - V_o^2)$$

$$P_o = \frac{1}{2} \rho A V^3 \frac{\left(1 + \frac{V_o}{V}\right) \left[1 - \left(\frac{V_o}{V}\right)^2\right]}{2}$$

- The power extracted by the blades is customarily expressed as a fraction of the upstream wind power in watts as follows:

$$P_o = \frac{1}{2} \rho A V^3 C_p$$

$$C_p = \frac{\left(1 + \frac{V_o}{V}\right) \left[1 - \left(\frac{V_o}{V}\right)^2\right]}{2}$$

C_p is the fraction of the upstream wind power that is extracted by the rotor blades and fed to the electrical generator.

The remaining power is dissipated in the downstream wind.

The factor C_p is called the power coefficient of the rotor or the rotor efficiency.

So, wind power available:

1. Is proportional to air density.
2. Is proportional to intercept area.
3. Is proportional to cube of velocity of air.

Intercept area is generally circular of diameter "D"

Therefore,

$$\begin{aligned} \text{Power Available} &= \frac{1}{2} \rho \frac{1}{4} \pi D^2 v^3 \\ &= \frac{1}{8} \rho \pi D^2 v^3 \text{ watts} \end{aligned}$$

Performance of Wind Turbines

- To estimate the performance of wind turbines, we need to consider the below parameters;
 - Power co-efficient
 - Tip speed ratio
 - Solidity

Power co-efficient

The power co-efficient defines as a ratio of power delivered by the rotor to the maximum power available in the wind turbine.

$$C_P = \frac{\text{Power Delivered by the turbine } (P)}{\text{Maximum power available at the turbine } (P_{max})}$$

Where

The maximum power available at the turbine (P_{max}) is;

$$P_{max} = \frac{1}{2} \rho A C_i^3$$

- C_i = Incoming wind velocity
- A = Cross-section area of wind stream
- ρ = Density of air

- **Tip-speed ratio**
- The tip speed ratio defines as the ratio of blade tip speed to the free stream wind speed.

$$\text{Tip speed ratio} = \frac{\text{blade tip speed } (C_B)}{\text{free stream wind speed}}$$

Blade tip speed is defined as;

$$C_B = \omega R$$

Where;

ω = angular speed of the rotor

R = radius of the tip of the rotor

This equation applies to the horizontal wind turbines. And in the case of the vertical wind turbine, the blade tip speed represents the peripheral speed at the middle of the blade length.

Solidity

Solidity is defined as the ratio of blade area to swept frontal area of the turbine.

Solidity of the wind turbine

Where;

C = mean chord length

R = radius of rotor blades

n = number of rotors blades

$$\text{solidity, } \gamma = \frac{\text{Blade area}}{\text{Swept frontal area}} = \frac{n C}{R}$$

The above equation is for the horizontal wind turbine.

For a vertical wind turbine, the above equation divides by 2.

Higher the solidity ratio use drag force and turns at a slower speed.

Lower the solidity ratio, use lift force and turn at higher speeds.

- Site Selection of Wind Power Plant
- The power produced by the wind turbine depends on the available wind speed. Therefore, the wind turbines are located at a place where persistent and strong wind is available. The wind varies daily. So, we need to analyze the data for a month or year.
- To select the location for a wind turbine, the below-listed matters need to be considered;

1. Wind speed
2. Grid structure
3. Distance
4. Altitude of location
5. Nature of ground
6. Land cost

Wind speed

- The power generated by the wind turbine depends on the cubic values of the velocity of the wind. Therefore, a small change in wind speed varies more generated power. We need to consider the average wind speed available for a particular location. For that, we required the data of wind speed for a year or month. After data analysis, we need to consider an average wind speed and select a site with a strong wind speed.

Grid structure

- The power generated by the wind turbine is transferred to the load via a grid. The power output of the wind turbine depends on the wind speed and it fluctuates with respect to time. So, power output is also fluctuating with respect to time which gives poor power quality. Hence, the connection of wind turbines with the grid is the most important task.

Distance

- The transmission line is used to connect the wind turbine with the substation or load center. If the distance of wind power plants is more, it will increase the transmission cost. Therefore, we need to select the site near the load center to reduce the transmission cost.

Altitude of location

- At high altitude, the wind density is high which increase the output of wind turbine. In a place where the altitude is not available, the tower size is increased to get a high altitude. The height of the wind turbine is calculated from the sea level.

Nature of ground

- To achieve high-density wind, the wind turbine is constructed at height. It requires a big and strong foundation to the ground. So, the nature of the ground is free from erosion and the place is free from land sliding problems.

Land cost

- The initial cost of a wind turbine is very high because it uses costly material and very big construction of blades. The cost of land is also including in the capital cost. therefore, the cost of land must be as low as possible to reduce the capital cost. in most cases, the wind turbines are placed the non-useable lands.

Components of WECS, Description of Components

The main components of a wind energy conversion system for electricity (Fig 1) are

1. Aero-turbine
2. Gearing
3. Coupling
4. Electrical generator
5. Controller

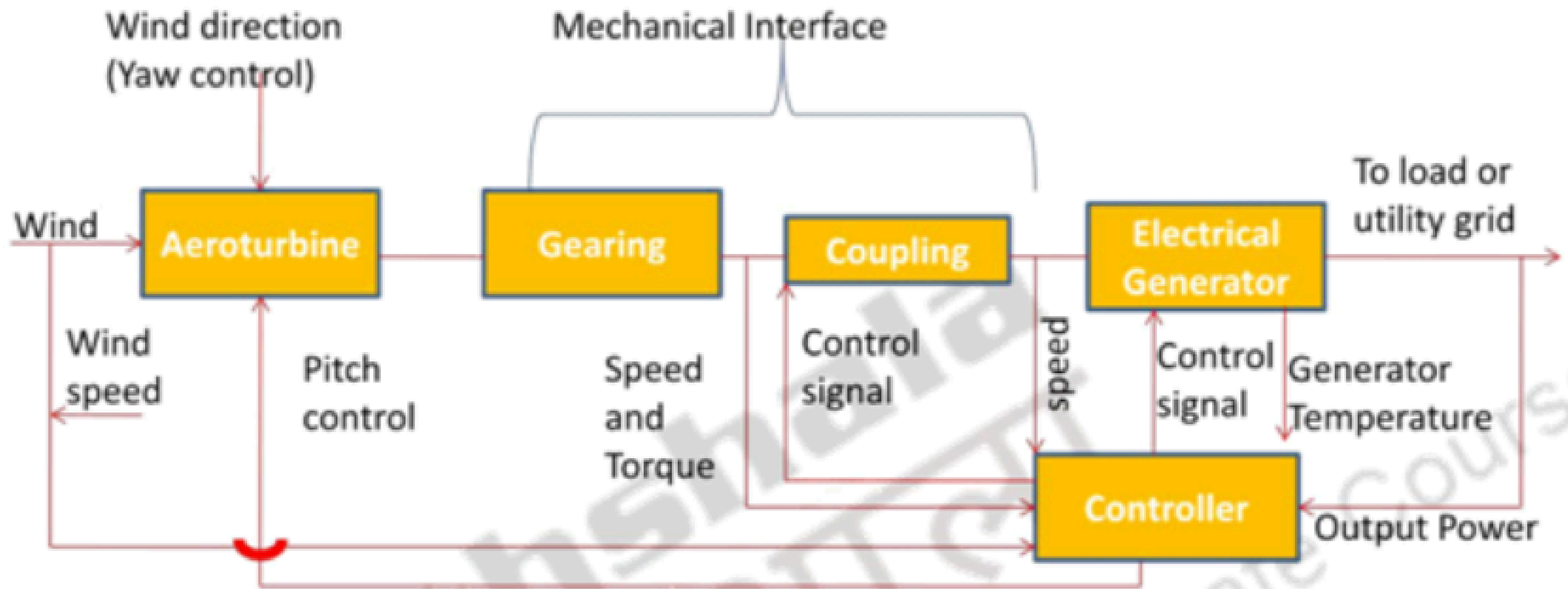

https://www.youtube.com/watch?v=y6fG-aIP_PU

Main Components of a wind-mill

Rotor (consists of three blades and a hub – the mechanical link between the blades and the low speed shaft)

3.1 Rotor: The component of wind turbine that is rotating and helps in conversion of kinetic energy to mechanical energy. It consists of blades and hubs.

3.2 Hub: The function of rotor hub is to connect rotor blades to the rotor shaft. This component controls the power generation of the wind turbine.

3.3 Blades: This is a rotating component of the system. This component is based on the principle of lift and drag (principle of aerodynamics). It converts kinetic energy first to mechanical energy and then transferred through shaft to generator for converting into electrical energy.

Two or three blades are common in the wind turbines. The wind blown over the blades lift the blades and rotate it. The two bladed wind turbines have lighter hub and so the whole structure is lighter. But three bladed wind turbines are aerodynamically efficient and have low noise..

The length of the blade is the important parameter for estimation of wind power generation potential of a wind turbine. The torque increases with more number of blades.

The blades are commonly made from composites mainly fiberglass or glass reinforced plastic (GRP) or carbon fiber reinforced plastics (CFRP). Wooden or epoxy laminates are also used for making blades.

Solidity is defined as the ratio of the projected area of the rotor blades on the rotor plane to the swept area of the rotor. High- solidity rotors use force for rotation and these rotors turn slowly. Low- solidity rotors have slender aerofoil and these rotors use lift force for rotation and turn faster.

Chord: It is the width of the blade which is across distance from one edge of the blade to the other edge.

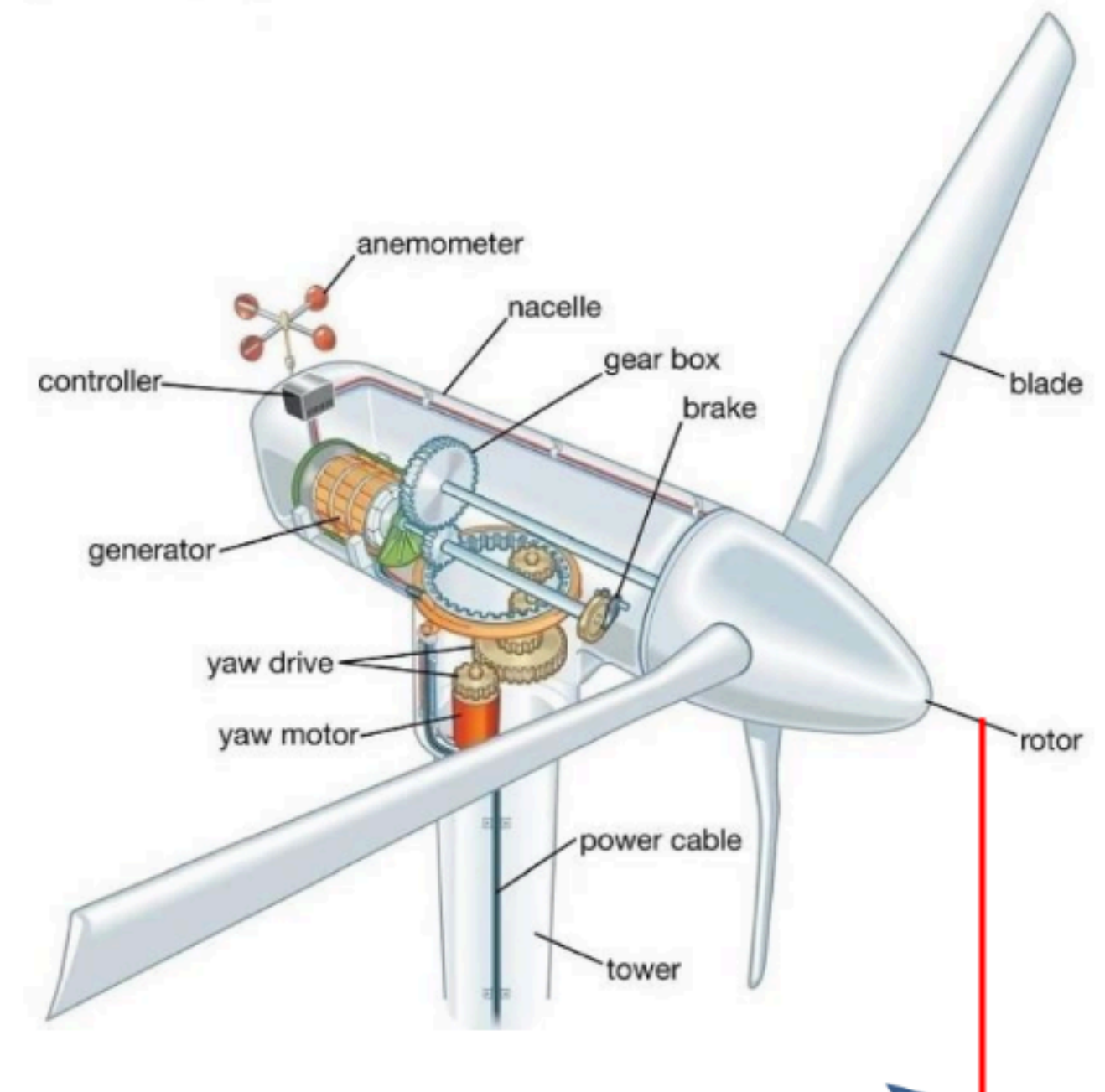

- **Nacelle:** The covered part of the wind turbine system over the top of tower is nacelle. It houses gear box, low speed shaft and high-speed shaft, generator, controller, and brake. It has an important role in protection of components of wind turbine from the various weather conditions. It also helps in reduction of noise produced from the rotation of wind turbine.
- **Gear box:** The function of gear box is to step up the speed as per needed by the electric generator. The low speed shaft is connected to the high speed shaft with gears. It increases the rotational speed that is required for the generator to generate electricity. The increase in rotational speeds is of the order 30-60 rpm to 1000-1800 rpm. This part is very costly. Some of the types of gear boxes are Planetary Gear Boxes, Parallel shaft gear.

- The wind turbine converts energy in the wind to rotary mechanical energy.
- This is capable with the help of pitch control and yaw control for proper operation.
- The step up gear and a coupling constitutes mechanical interface.
- This helps in transmission of rotary mechanical energy to an electric generator and power output is connected to the load or power grid.
 - Yaw control is fixed in wind turbines in the areas where there is change in wind direction.
 - A motor rotates the turbine slowly about the vertical axis so as to face the blades into the wind.
 - The controller helps in sensing different parameters like wind speed, wind direction, shafts speed and torques at various points, power generated and temperature in the generator.
 - It also senses the control signals for comparing electrical output to the wind energy input. This also protects the wind turbine system from extreme conditions (like strong winds, electrical faults, etc.).

-

- **Generator:** The conversion of rotational energy to electrical energy is carried out by generator. In general the wind driven electric generator produces 50-cycle AC electricity. The types of generators are
 - – Synchronous generator (Electrically excited, permanent magnet),
 - – Asynchronous generator (SQIG -Squirrel cage induction generators, Slip ring)
- **Controller:** The grid quality electric current is controlled by the controller of the turbine system. The controller starts up the machine at cut-in wind speed (generally 3 m/s) and shuts off the machine at cut-out wind speed (generally 25 m/s) as per the design requirement.
- The controller measures and controls parameters like Voltage, current, frequency, Temperature inside nacelle, Wind direction, Wind speed, The direction of yawing, shaft speed, Over-heating of the generator, Hydraulic pressure level, Correct valve function, Vibration level, Twisting of the power cable, Emergency brake circuit, Overheating of small electric motors for the yawing, hydraulic pumps, Brake caliper adjustment etc.

- Different control methods are used either to optimize or limit power output.
- You can control a turbine by controlling the
 - generator speed,
 - blade angle adjustment and
 - rotation of the entire wind turbine.
Blade angle adjustment and turbine rotation are also known as pitch and yaw control, respectively.
- The purpose of **pitch control** is to maintain the optimum blade angle to achieve certain rotor speeds or power output.
- You can use pitch adjustment to stall and furl, two methods of pitch control.
- By stalling a wind turbine, you increase the angle of attack, which causes the flat side of the blade to face further into the wind.
- Furling decreases the angle of attack, causing the edge of the blade to face the oncoming wind.
- Pitch angle adjustment is the most effective way to limit output power by changing aerodynamic force on the blade at high wind speeds.
- This maintains the turbine's safety in the event of high winds, loss of electrical load, or other catastrophic events.



Fig. 11. Pitch control

- Yaw is the horizontal moving part of the turbine.
- It turns clockwise or anticlockwise to face the wind.
- The yaw has two main parts: the yaw motor and the yaw drive.
 - The yaw drive keeps the rotor facing the wind when the wind direction varies.
 - The yaw motor is used to move the yaw.
- Yaw control ensures that the turbine is constantly facing into the wind to maximize the effective rotor area and, as a result, power.
- Because wind direction can vary quickly, the turbine may misalign with the oncoming wind and cause power output losses.



Fig. 12. **Yaw** control

- **13 Pitch:** The electricity production is controlled by pitch under different wind intensities. Blades are turned or pitched, out of the wind to control the rotor speed and keep the rotor from turning in winds that are too high or too low to produce electricity.

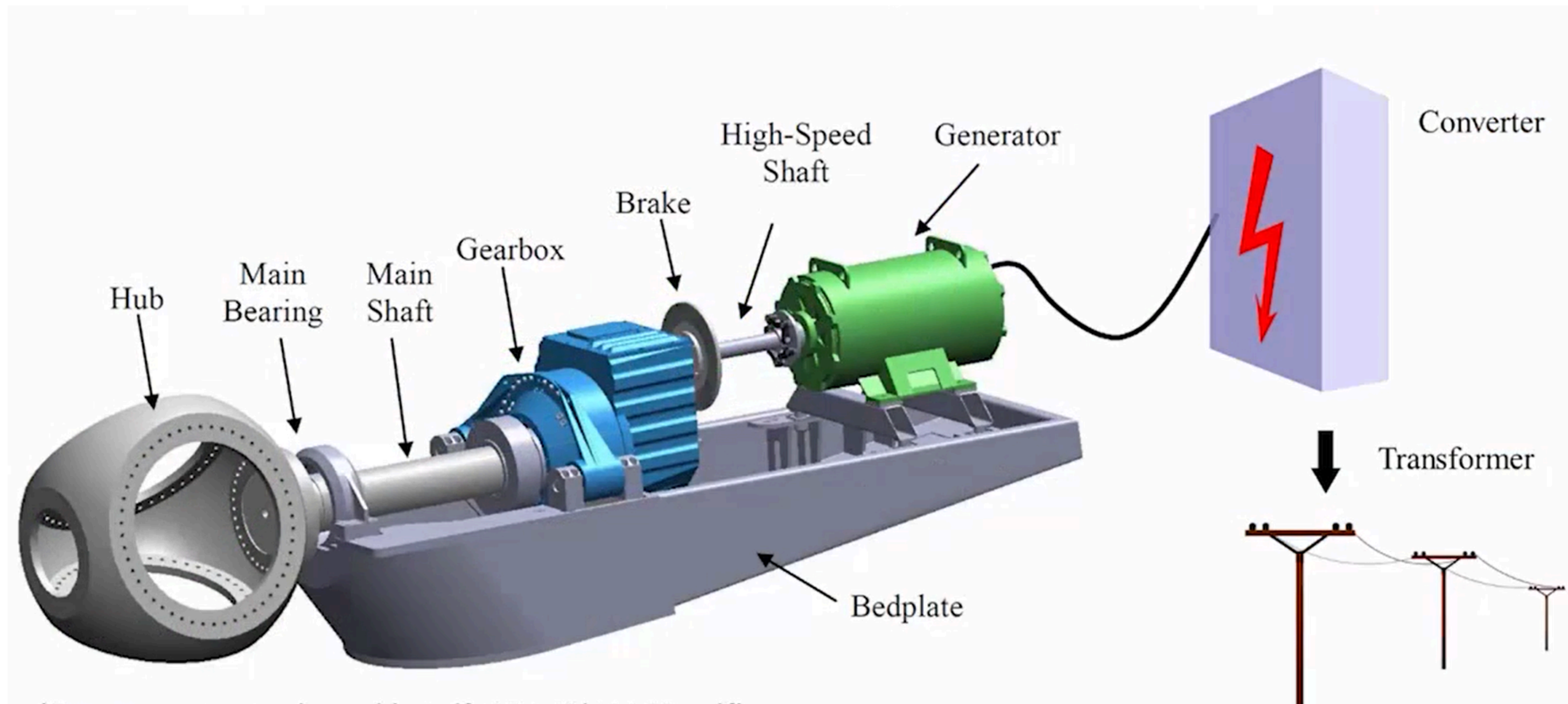

Types of Wind Turbine Generators

Wind Power (Contd.)

- The building block to harvest wind power is a **wind turbine generating (WTG) unit**
- A **WTG** includes four main components:
 - Wind turbine
 - Electric machine (**generator**)
 - Power-electronic converter/conditioner
 - **WTG**-level controller
- A **Wind Power Plant (WPP)** is a cluster of **WTG** units that are collectively interfaced to the host power system at a point of interconnection (**POI**)
 - **WTG** units are designed to collectively interact with the host power system so as to ensure satisfactory performance.



Wind Turbines

- Most modern wind turbines have three blades
- Based on the axis of rotation, wind turbines can be classified into two basic types:
 - Horizontal Axis Wind Turbine (**HAWT**)
 - Vertical Axis Wind Turbine (**VAWT**)
- The **HAWT** are more efficient in extracting the kinetic energy from the wind, and are widely used
- There are two types of **HAWT** rotor configurations: upwind and downwind
- The dominant **WTG Technology**, particularly for applications in WPPs, is based on the **horizontal axis, three bladed, upwind turbine structure**



Wind Turbine Generators (WTGs)

- **Wind Turbine Components:**
 - ☞ Wind turbine runs at low speed (**0.5 hz**)
 - ☞ Mechanical drive train includes a **gear box**
 - Converts low speed of turbine to high speed of generator
- **Mechanical speed regulation:**
 - ☞ Blade pitch angle control
 - Each blade rotated about longitudinal axis
 - Variable speed
 - ☞ Stall control
 - No pitch actuators required
 - Fixed speed
- **Types of generators**
 - ☞ Induction generator
 - ☞ Synchronous generator
 - ☞ Doubly fed induction generator
- **WTG ratings range from 25 kW to 7.5 MW.....**

Typical WTG “Power Curve”

- Figure below shows typical output versus wind speed characteristics of wind turbines:

- The **cut-in, rated and cut-out speeds** shown are typical for utility-scale WTGs.

- Generally, WTGs are designed to work at maximum aerodynamic efficiency between cut-in and rated wind speed

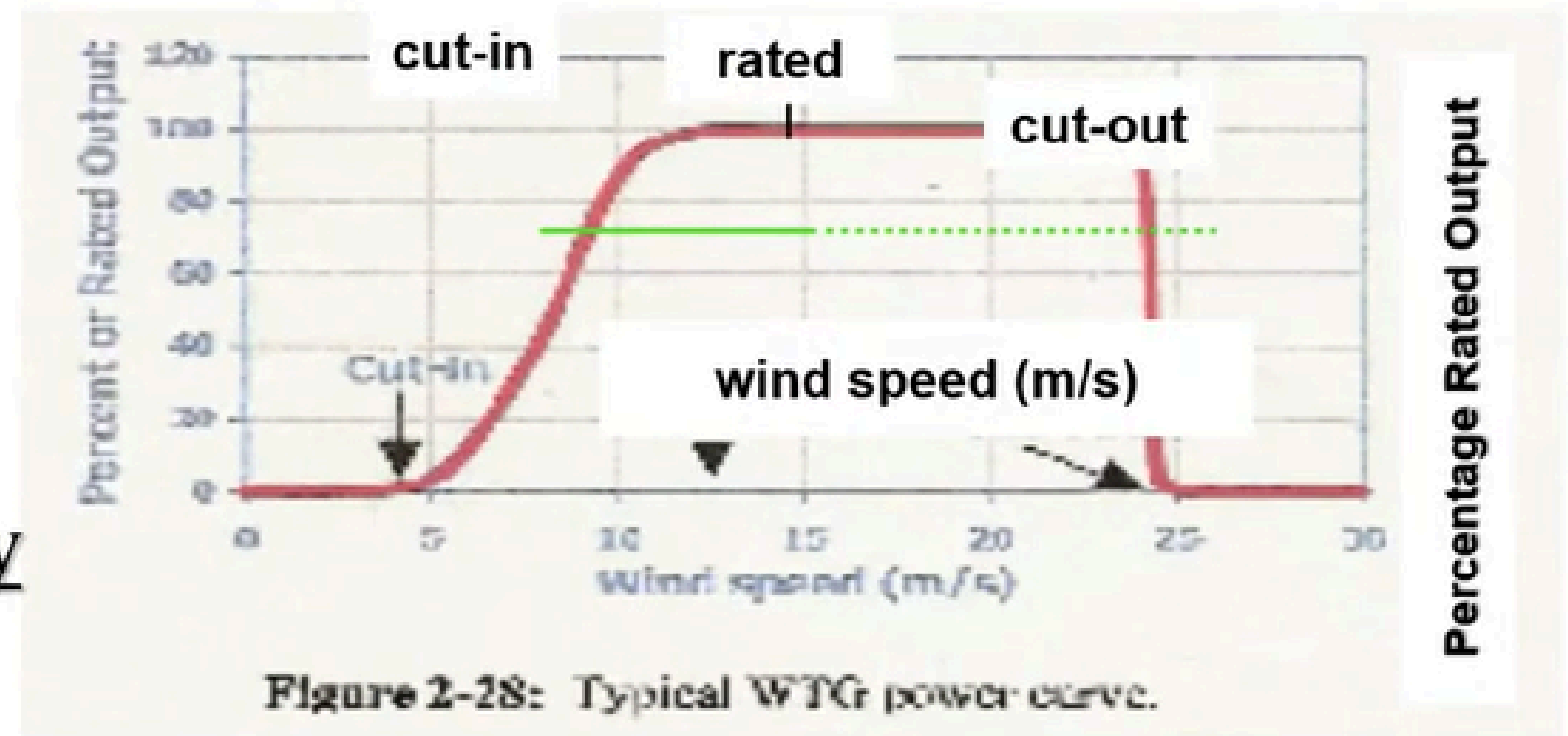

- **For wind speeds higher than rated and lower than cut-out:**

- Blade Pitching or blade stalling is used to maintain loading within the equipment's rating

- WTGs shut down for wind speeds higher than cut-out speed to avoid excessive mechanical stress



Types of Wind Turbine Generator Technologies

Four Major Types of WTG Technologies used:

1. **Squirrel Cage Induction Generators** driven by fixed-speed, stall-regulated wind turbines
2. **Induction Generators** with variable external rotor resistance driven by a variable-speed, pitch regulated wind turbines
3. **Doubly-Fed Induction Generators** driven by variable-speed, pitch regulated wind turbines
4. **Synchronous or Induction Generators with full converter interface** (back-to-back frequency converter), driven by variable-speed, pitch regulated wind turbines



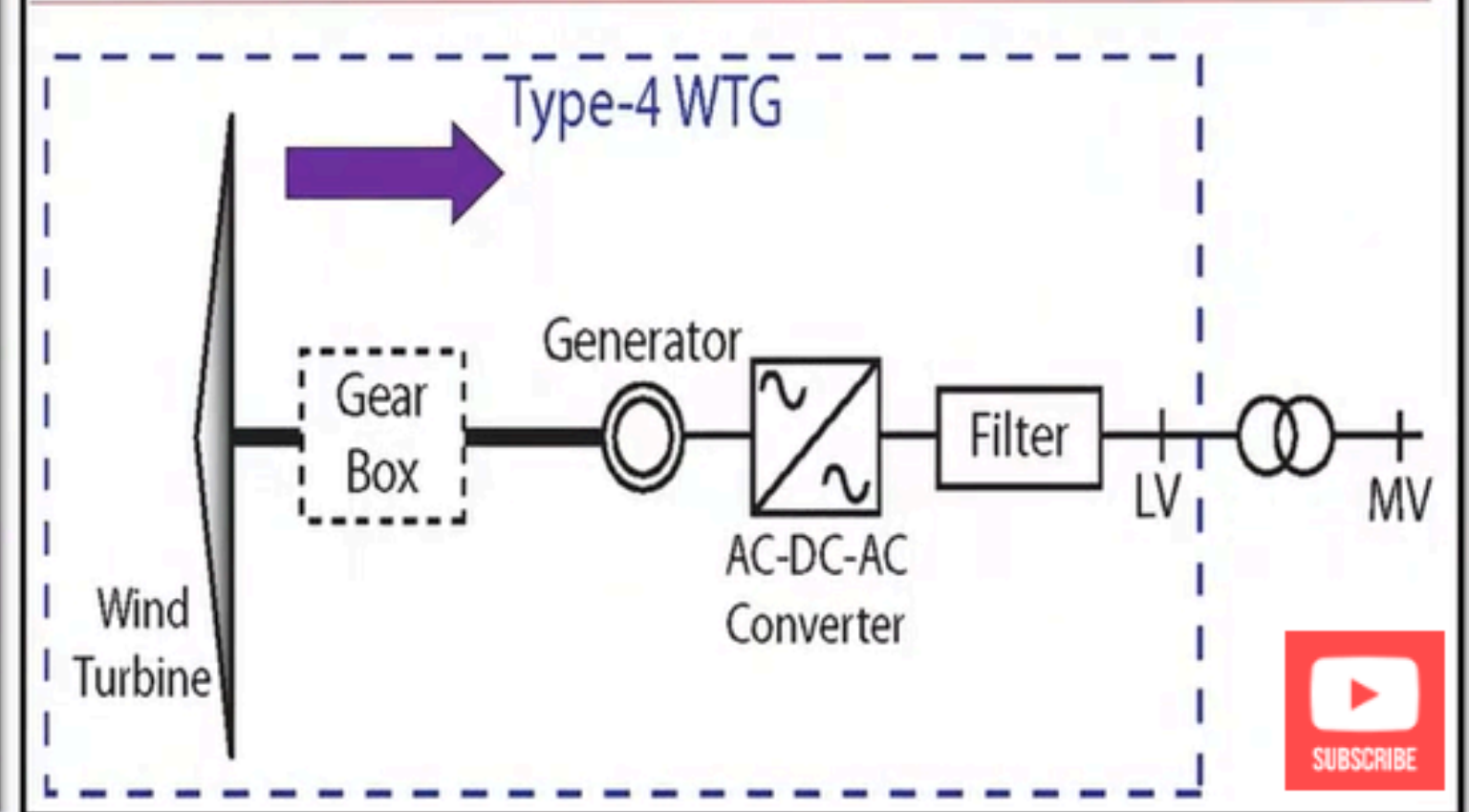
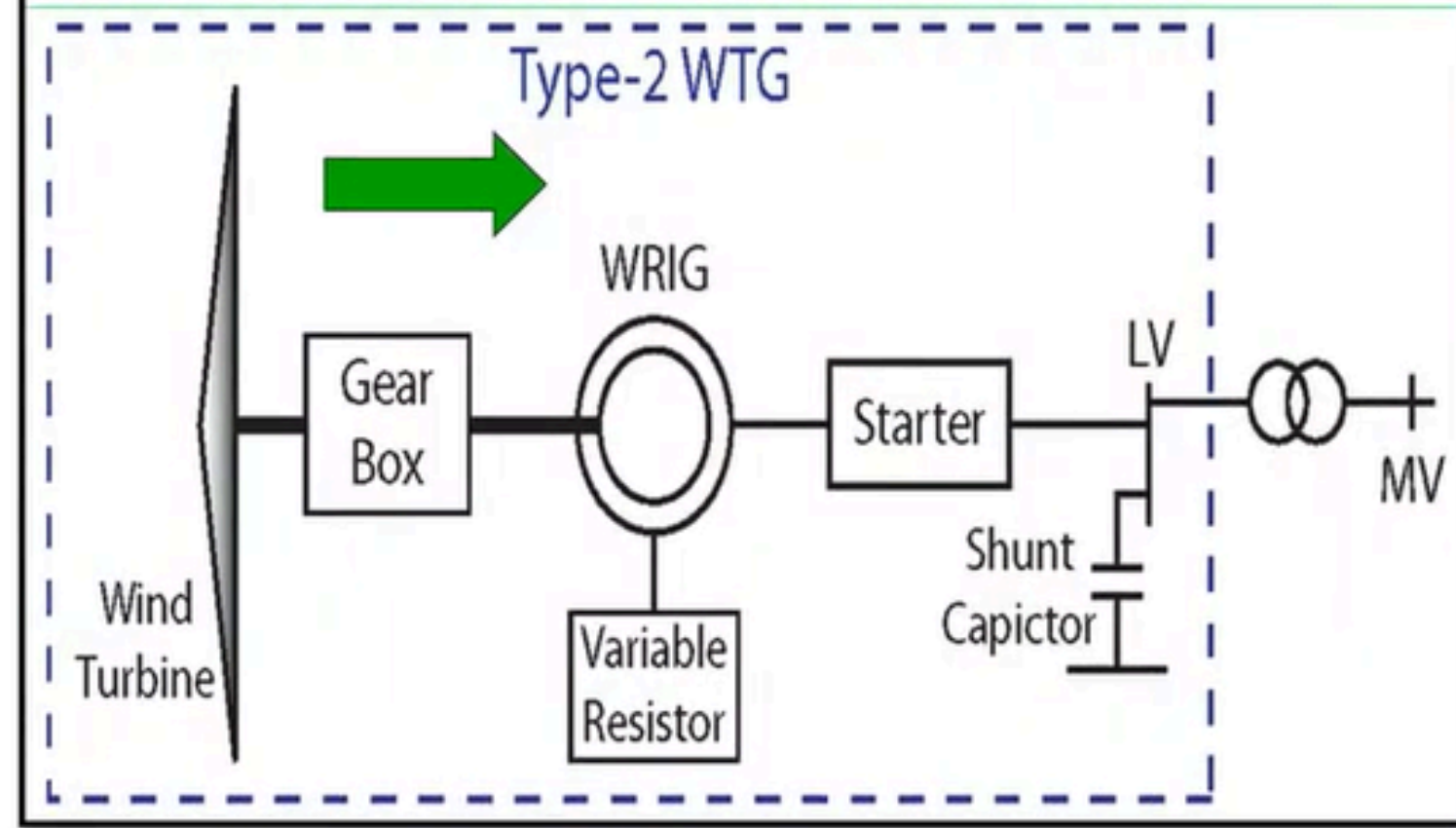
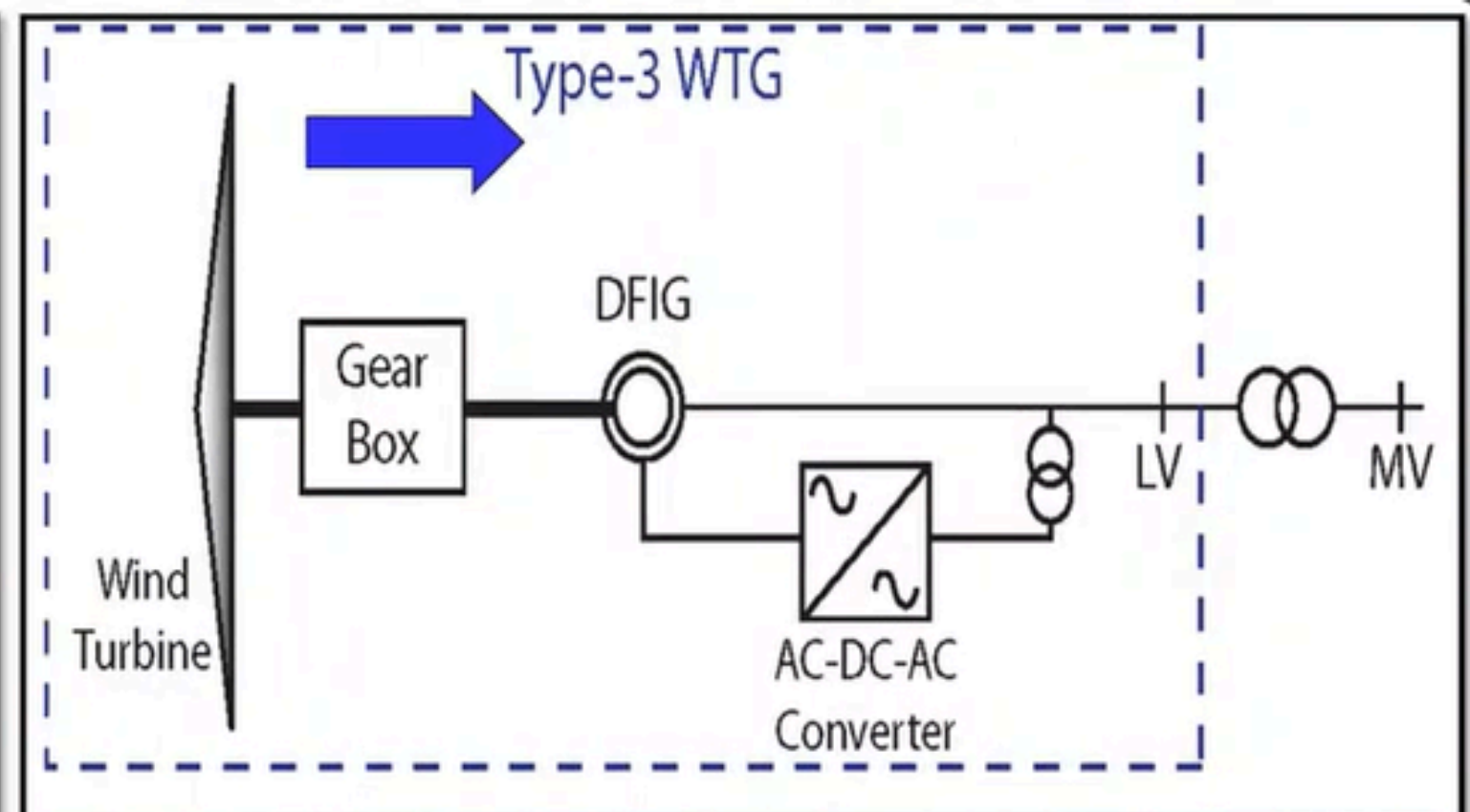
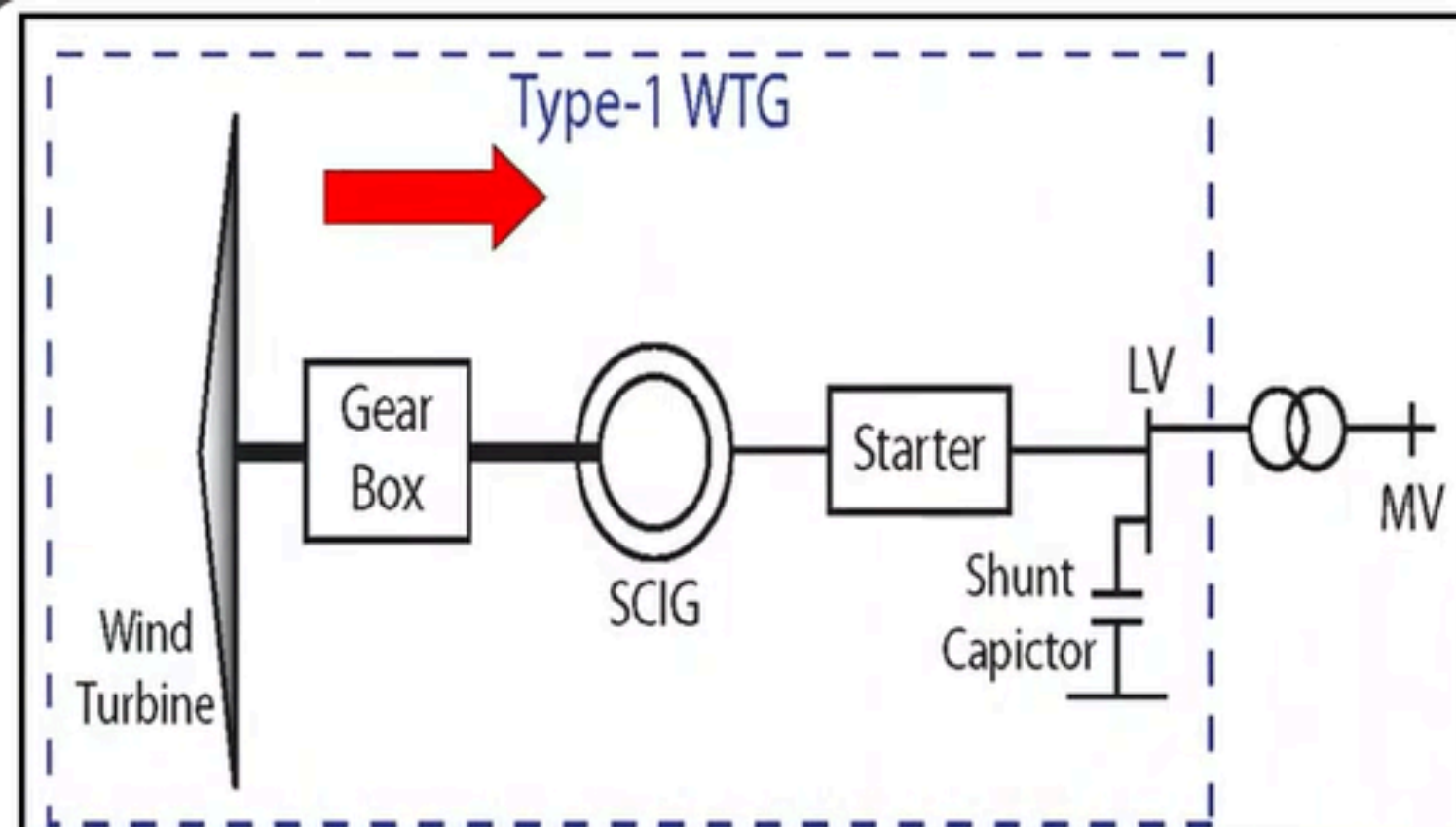

Type 1: Fixed Speed WTG

- **Generator** is an **Induction Generator**, which is directly interfaced with the host utility network
 - Rotor speed is determined by grid frequency, regardless of wind speed
- **Induction generator** equipped with an electronic starter and shunt capacitor banks for reactive power compensation
- **Main features:** simplicity, robustness of components, and relatively low cost
- **Drawbacks:** excessive mechanical stress; significant fluctuations in output quantities
- Widely used in the early 1990s; not used for large-size WTGs and WPPs

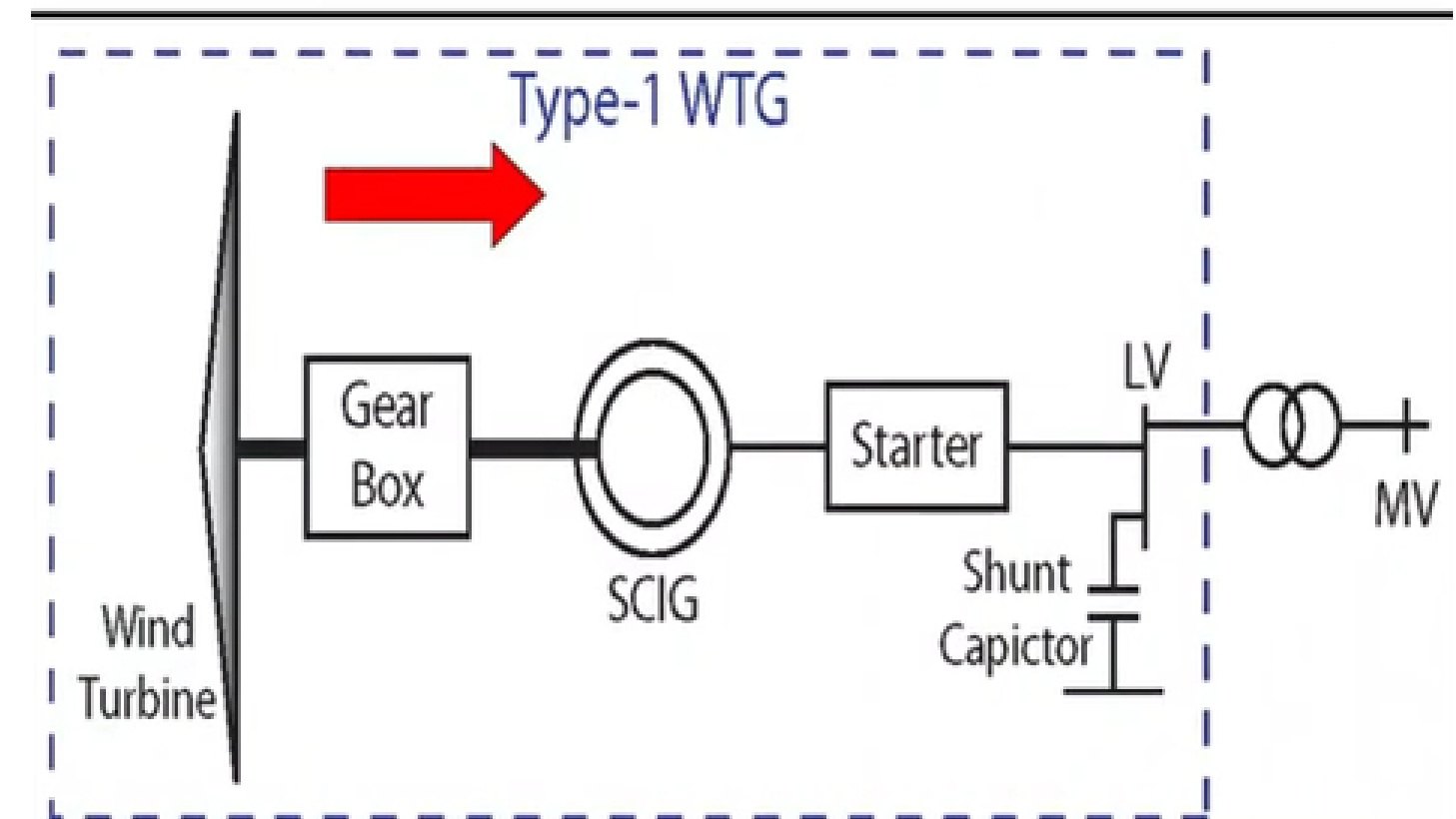

Type 2: Limited Variable-Speed WTG

- **Generator** is a wound-rotor induction generator
 - Equipped With A Rotor Resistor Adjustment Device, &
 - **Enables Slip Control, Typically Up To 10%**
- **Shunt Capacitor System** for reactive power compensation
- **As compared to Type 1 WTG, slightly aerodynamically more efficient and has modestly lower drive-train mechanical stress**
- Not the preferred choice for present-day large-size **WTGs and WPPs**



Type 3: Variable-Speed WTG with DFIG

- WTG is composed of a pitch-controlled wind turbine, a gear box, and a doubly-fed induction generator (DFIG)
- Stator of the DFIG is directly connected to the host power system
- Three-phase rotor circuit is connected to the grid through a back-to-back voltage-sourced converter system
 - Applies voltage across the rotor that is regulated by two rotor current controllers
- Typically provides variable speed operation from about **40% to +30%** of the nominal power system frequency
- Aerodynamically more efficient; lower drive-train mechanical stress; and lower power/voltage fluctuations



Doubly Fed Induction Generator (DFIG)

- **Wound rotor** induction generator with slip rings
- **Rotor is fed from a three-phase variable frequency source, thus allowing variable speed operation**
 - ☞ reduction of mechanical stress; higher overall efficiency, reduced acoustical noise
- **The variable** frequency supply to rotor is attained through the use of two voltage-source converters linked via a capacitor
- **Since the converter** system handles only the rotor quantities, its rating is significantly smaller (**about 30%**) than the generator rating

Note: A more appropriate designation for this type of generator is:

Doubly Fed Asynchronous Generator (DFAG)



Doubly Fed Induction Generator

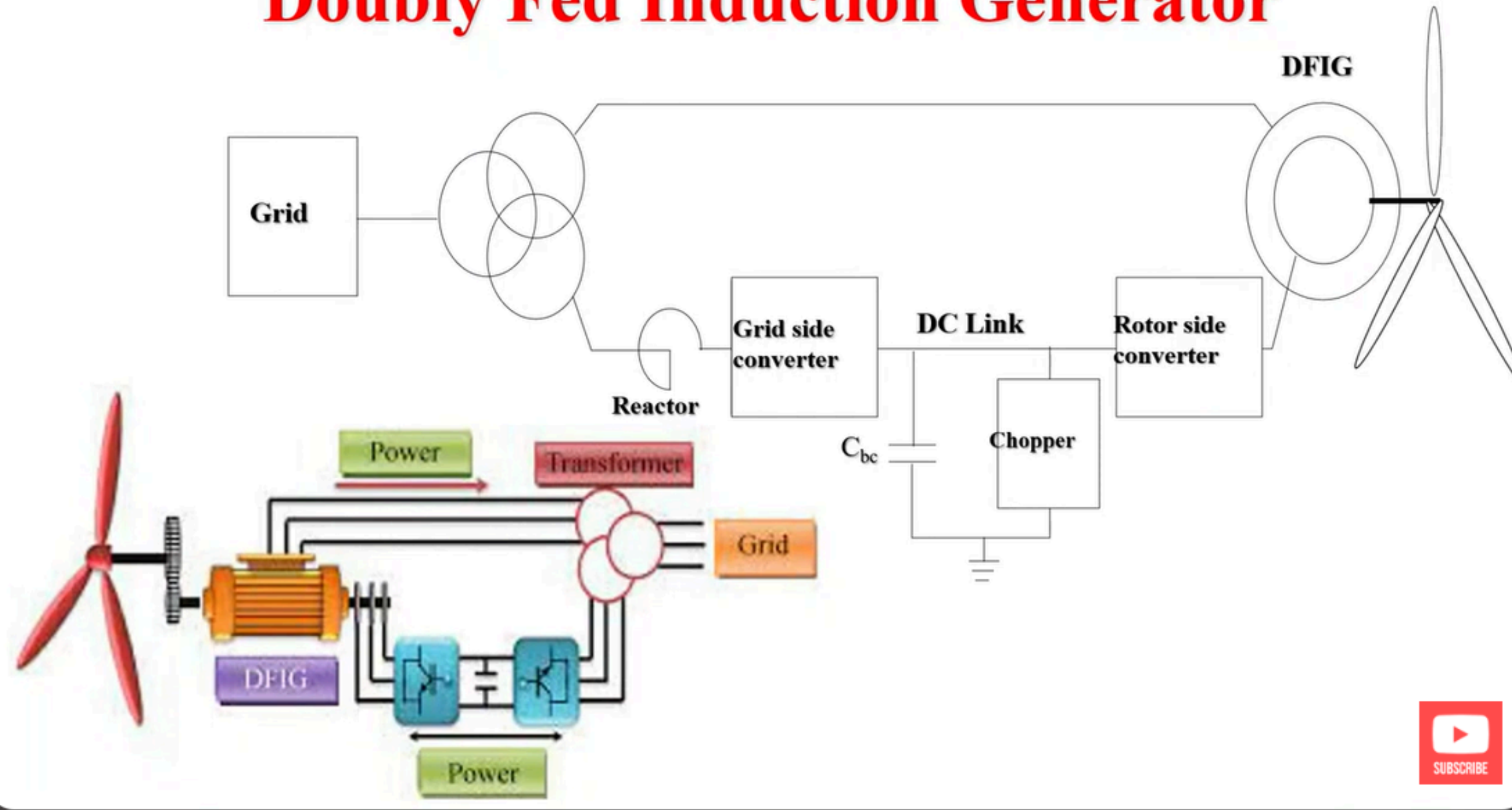

Control of Rotor- Side Converter

- **The converters handle ac quantities:**
 - ☞ rotor-side converter carries slip frequency current
 - ☞ stator-side converter carries grid frequency current
- **Hence, they are controlled using vector-control techniques:**
 - ☞ based on the concept of a rotating reference frame and projecting currents on such a reference
 - ☞ such projections referred to as d- and q-axis components
- With a suitable choice of reference frame, AC quantities appear as DC quantities in the steady state



Control of Rotor- Side Converter

- **In flux-based rotating frames:**
 - ☞ changes in the d-axis component of current will lead to reactive power changes
 - ☞ changes in the q-axis component will vary active power
- **This allows independent control of active and reactive power of the stator**
 - ☞ **Implemented through rotor-side converter control**
 - ☞ **An important aspect of the DFAG concept !**
- Since rotor flux tracks the stator flux, air gap torque provides no damping of shaft oscillations
 - ☞ additional modulating signal has to be added



Protection System

- **Rotor Current Protection:**

- ☞ **Limits** current in the rotor side converter
- ☞ **If current rises** above set value, a crowbar is activated
 - short-circuits the rotor winding at the slip rings with a static switch
 - Generator operates as a squirrel cage induction motor
 - In newer units, an “active crowbar” is used
- ☞ **Typically, the** case when the voltage at the terminals of the generator decreases rapidly, for example during a fault in the grid
- ☞ **In order to avoid** overspeeding of turbine, the speed reference for the pitch control is reduced simultaneously
 - **increases pitch** angle and reduces mechanical power



Economics of Wind Energy Conversion Systems,

Economics of Wind Energy:

The wind turbine is the most expensive component of most wind farms. The indicative cost breakdowns for a large offshore wind turbine are given below. The reality is that a range of costs exists, depending on the country, maturity of the wind industry in that country and project specifics. The two most expensive components are the towers and rotor blades, with these contributing around half of the total cost. After these two components, the next largest cost component is the gearbox. But this underestimates the importance of gearboxes, as these generally are an important part of the Operations and Maintenance (O&M) costs, as they can require extensive maintenance. Onshore wind turbines, with their smaller sizes, will tend to have slightly lower shares for the tower and blades.

sections from rolled steel; a lattice structure or concrete are cheaper options.

Rotor blades 22.2% Varying in length up to more than 60 metres, blades are manufactured in specially designed moulds from composite materials, usually a combination of glass fibre and epoxy resin. Options include polyester instead of epoxy and the addition of carbon fibre to add strength and stiffness.

Rotor hub 1.37% Made from cast iron, the hub holds the blades in position as they turn.

Rotor bearings 1.22% Some of the many different bearings in a turbine, these have to withstand the varying forces and loads generated by the wind.

Main shaft 1.91% Transfers the rotational force of the rotor to the gearbox.

Main frame 2.80% Made from steel, must be strong enough to support the entire turbine drive train, but not too heavy.

Gearbox 12.91% Gears increase the low rotational speed of the rotor shaft in several stages to

Yaw system 1.25% Mechanism that rotates the nacelle to face the changing wind direction.

Pitch system 2.66% Adjusts the angle of the blades to make best use of the prevailing wind.

Power converter 5.01% Converts direct current from the generator into alternating current to be exported to the grid network.

Transformer 3.59% Converts the electricity from the turbine to higher voltage required by the grid.

Brake system 1.32% Disc brakes bring the turbine to a halt when required.

Nacelle housing 1.35% Lightweight glass fibre box covers the turbine's drive train.

Cables 0.96% Link individual turbines in a wind farm to an electricity sub-station.

Screws 1.04% Hold the main components in place, must be designed for extreme loads.

Factors Influencing the Cost of Energy Generation

- 1. The cost of wind energy varies widely depending upon the wind speed at a given project site:
- 2. Improvements in turbine design bring down costs:
- 3. A large wind farm is more economical than a small one:
- 4. Transmission, tax, environmental, and other policies also affect the economics of wind:

1. The cost of wind energy varies widely depending upon the wind speed at a given project site: The energy that can be tapped from the wind is proportional to the cube of the wind speed, so a slight increase in wind speed results in a large increase in electricity generation.

Consider two sites, one with an average wind speed of 22.50 kilometer per hour (kmph) and the other with average winds of 25.75 kmph. All other things being equal, a wind turbine at the second site will generate nearly 50% more electricity than it would at the first location.

$$P_{available} = \frac{1}{2} \rho A V_i^3$$
$$P_{available} \propto V_i^3$$

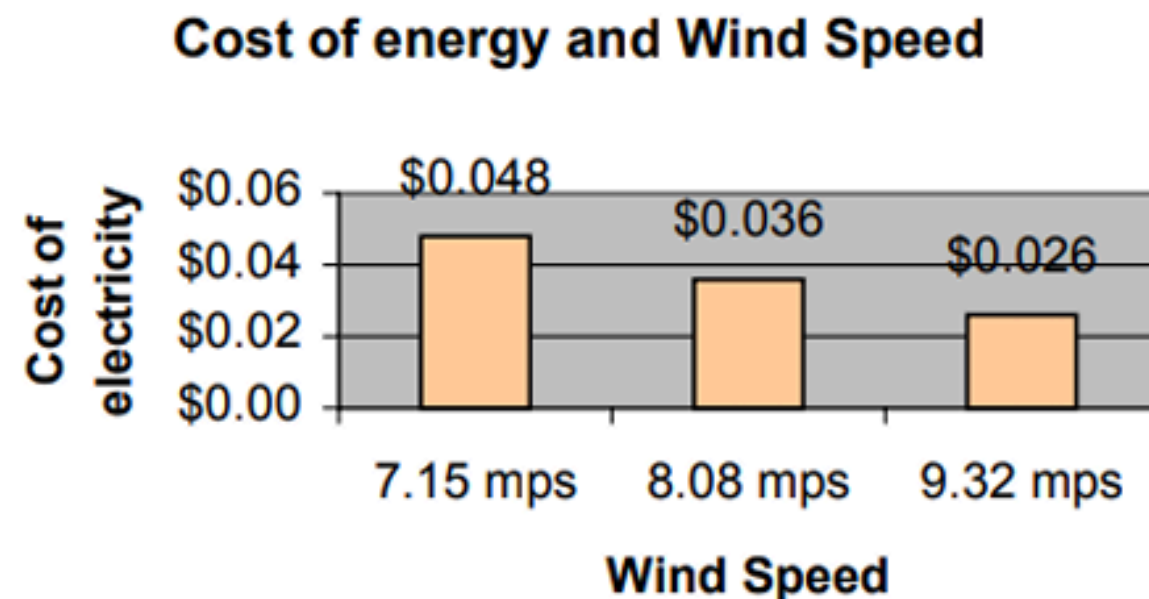

mps = miles per hour

2. Improvements in turbine design bring down costs: The taller the turbine tower and the larger the area swept by the blades, the more powerful and productive the turbine. The swept area of a turbine rotor (a circle) is a function of the square of the blade length (the circle's diameter).

$$P_{available} = \frac{1}{2} \rho A V_i^3$$

$$P_{available} \propto A$$

$$P_{available} \propto D^2$$

	1981	2000
Rated Capacity	1981: 25 kW	2000: 1,650 kW
Rotor Diameter	10 meters	71 meters
Total Cost (\$000)	\$65	\$1,300
Cost per kW	\$2,600	\$790
Output, kWh/year	45,000	5.6 million

Therefore, a 5-times increase in rotor diameter (from 10 meters on a 25-kW turbine like those built in the 1980s to 50 meters on a 750-kW turbine common today) yields a 55-times increase in yearly electricity output, partly because the swept area is 25 times larger and partly because the tower height has increased substantially, and wind speeds increase with distance from the

Advances in electronic monitoring and controls, blade design, and other features have also contributed to a drop in cost. The following table shows how a modern 1650-KW turbine generates 120 times the electricity at 20 times the cost of an older 25kW-turbine:

3. A large wind farm is more economical than a small one:

- Assuming the same average wind speed of 29 kmph and identical wind turbine sizes, a 3–MW wind project delivers electricity at a cost of \$0.059 per kWh and a 51-MW project delivers electricity at \$0.036 per kWh—a drop in costs of \$0.023, or nearly 40%.
- Any project has transaction costs that can be spread over more kilowatt hours with a larger project.
- Similarly, a larger project has lower O&M (operations and maintenance) costs per kilowatt-hour because of the efficiencies of managing a larger wind farm.

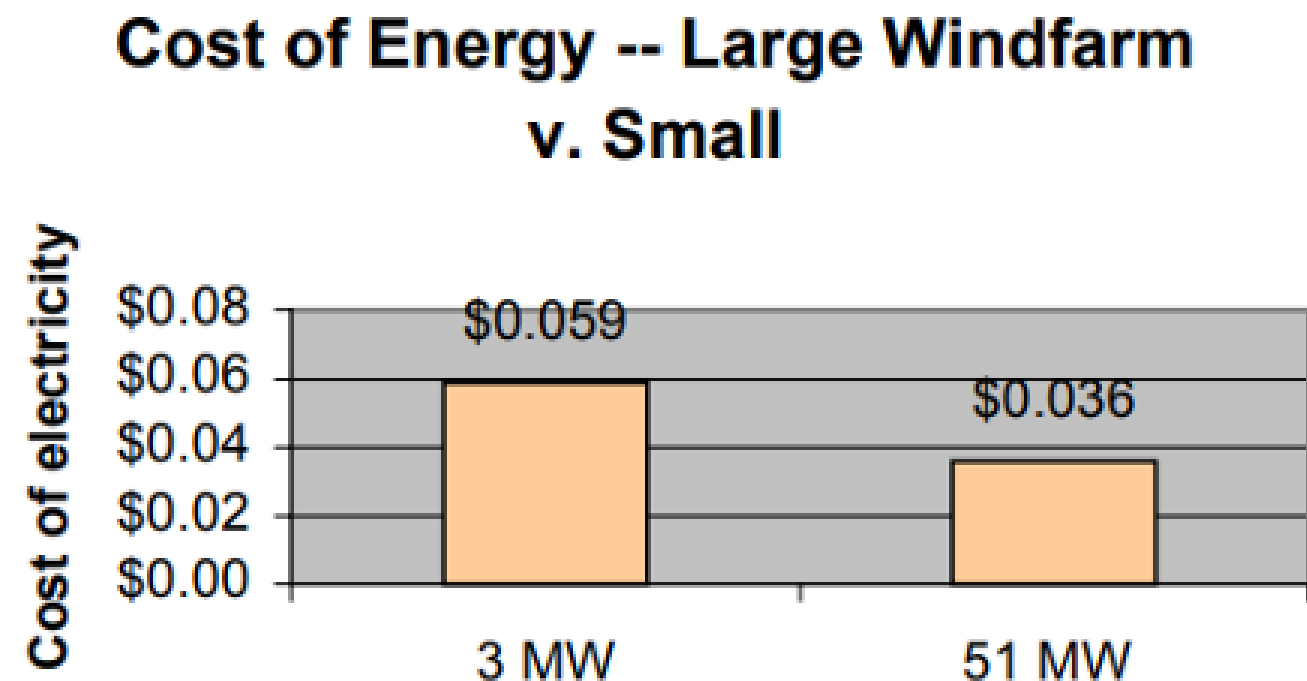

4. Transmission, tax, environmental, and other policies also affect the economics of wind:

- Transmission and market access constraints can significantly affect the cost of wind energy. Since wind speeds vary, wind plant operators cannot perfectly predict the amount of electricity they will be delivering to transmission lines in a given hour.
- Deviations from schedule are often penalized without regard to whether they increase or decrease system costs. Interconnection procedures are not standardized, and utilities have on occasion imposed such difficult and burdensome requirements on wind plants for connection to transmission lines that wind companies have chosen to build their own lines instead.
- As electricity markets are restructured and long-term power purchase agreements give way to trading on power exchanges, transmission and market access conditions will play an increasingly important role in the economics of a wind project.

Linking Wind Turbines
onto the Grid,

Typical technical features of such a wind power plant (wind farm) are:

- The wind generator output which is typically 440 volts AC is raised to an intermediate level of 11 kV by a pad-mounted transformer.
- An overhead transmission line provides the link to the site substation, where the voltage is raised again to the grid level say 33kV or 132 kV. (These values of voltages given are only typical.)
- Actual values in a given wind farm depend on the total number of wind turbines in a farm, their total power levels etc and may vary from site to site.
- A centralized site computer located in the substation, sometimes using multiplexer and remote radio links or fiber optical links, controls the wind turbines in response to the wind conditions and the load demand

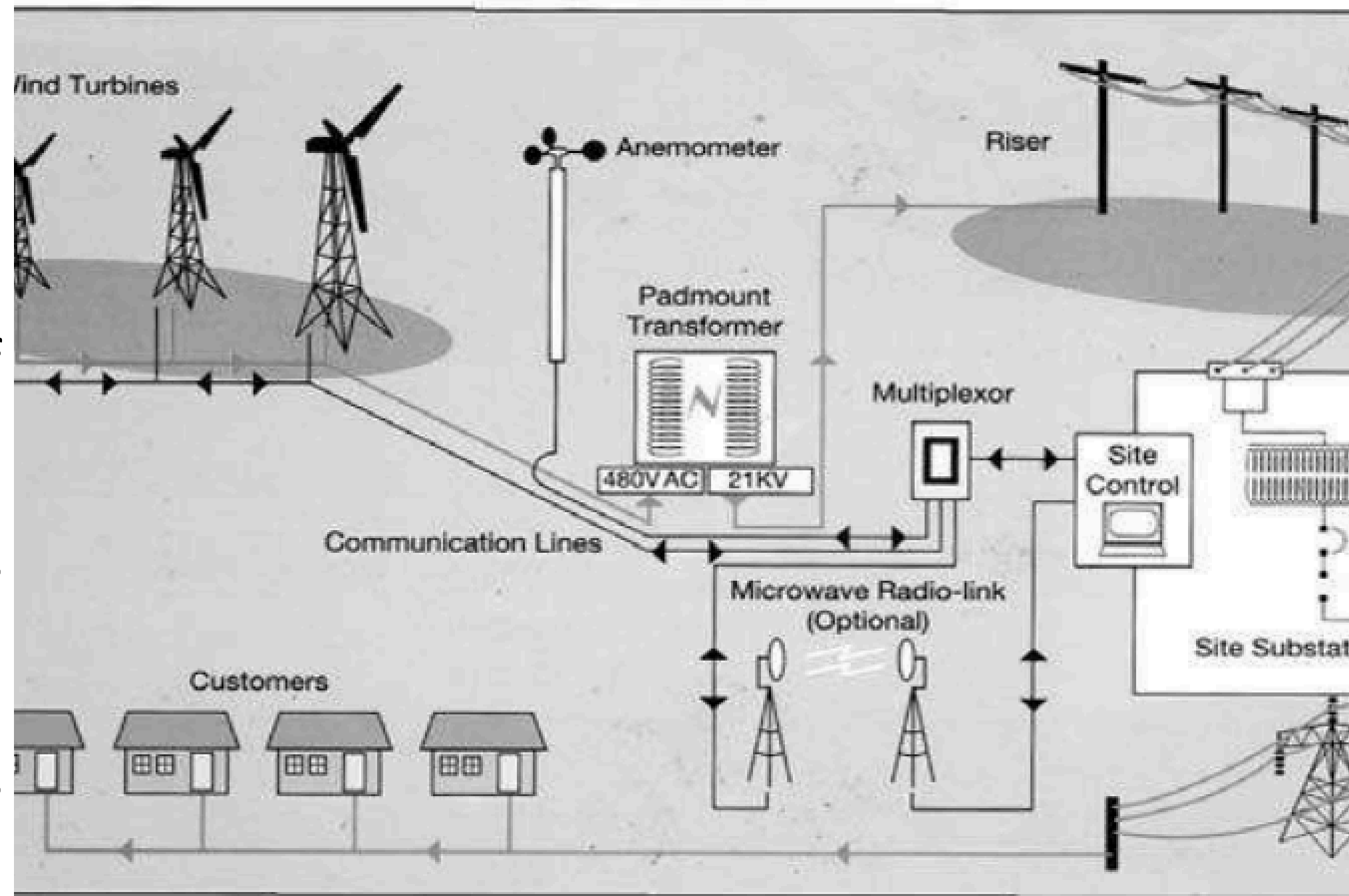

11: Electrical system layout of a Typical Grid-connected wind system.

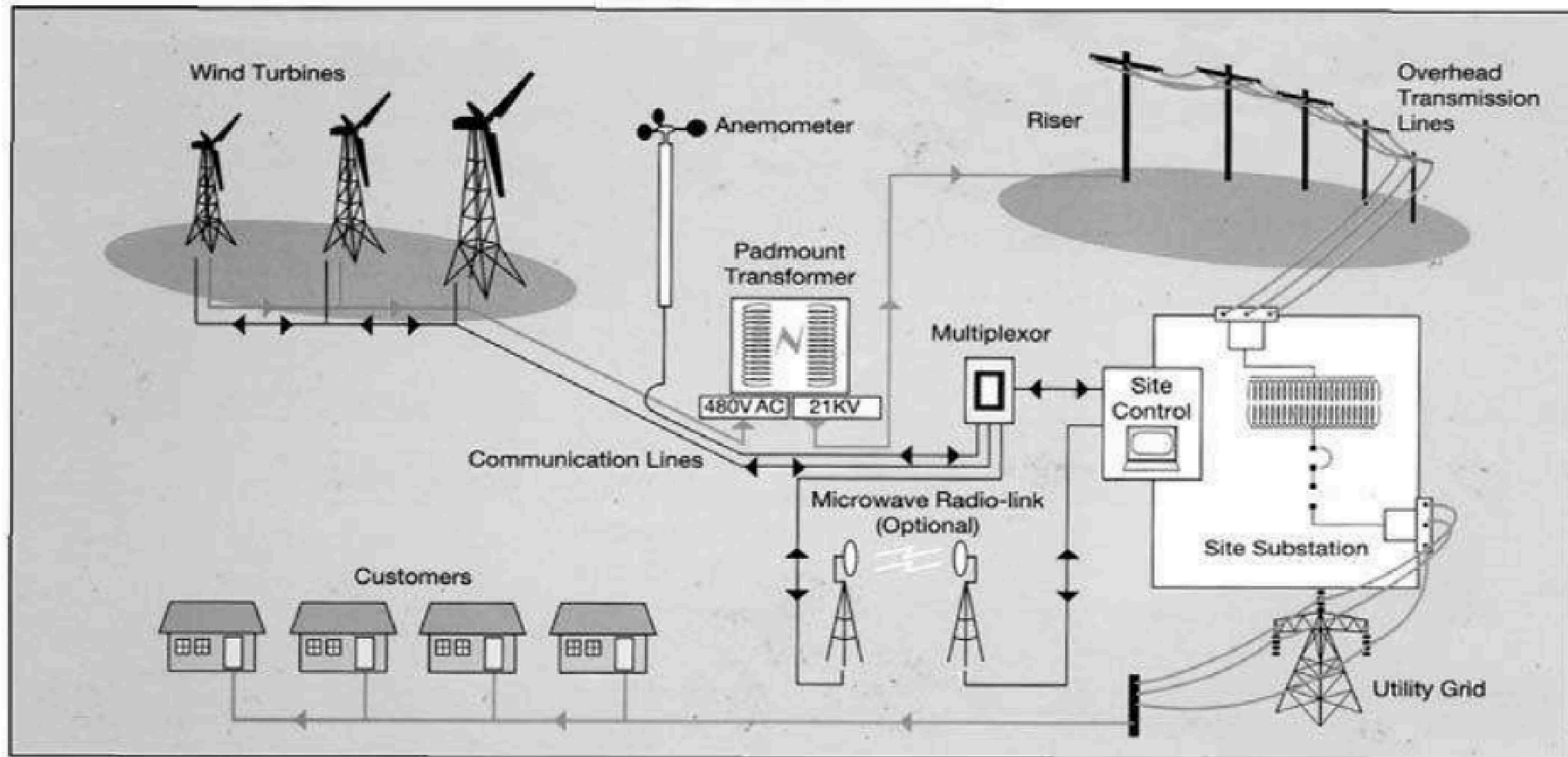
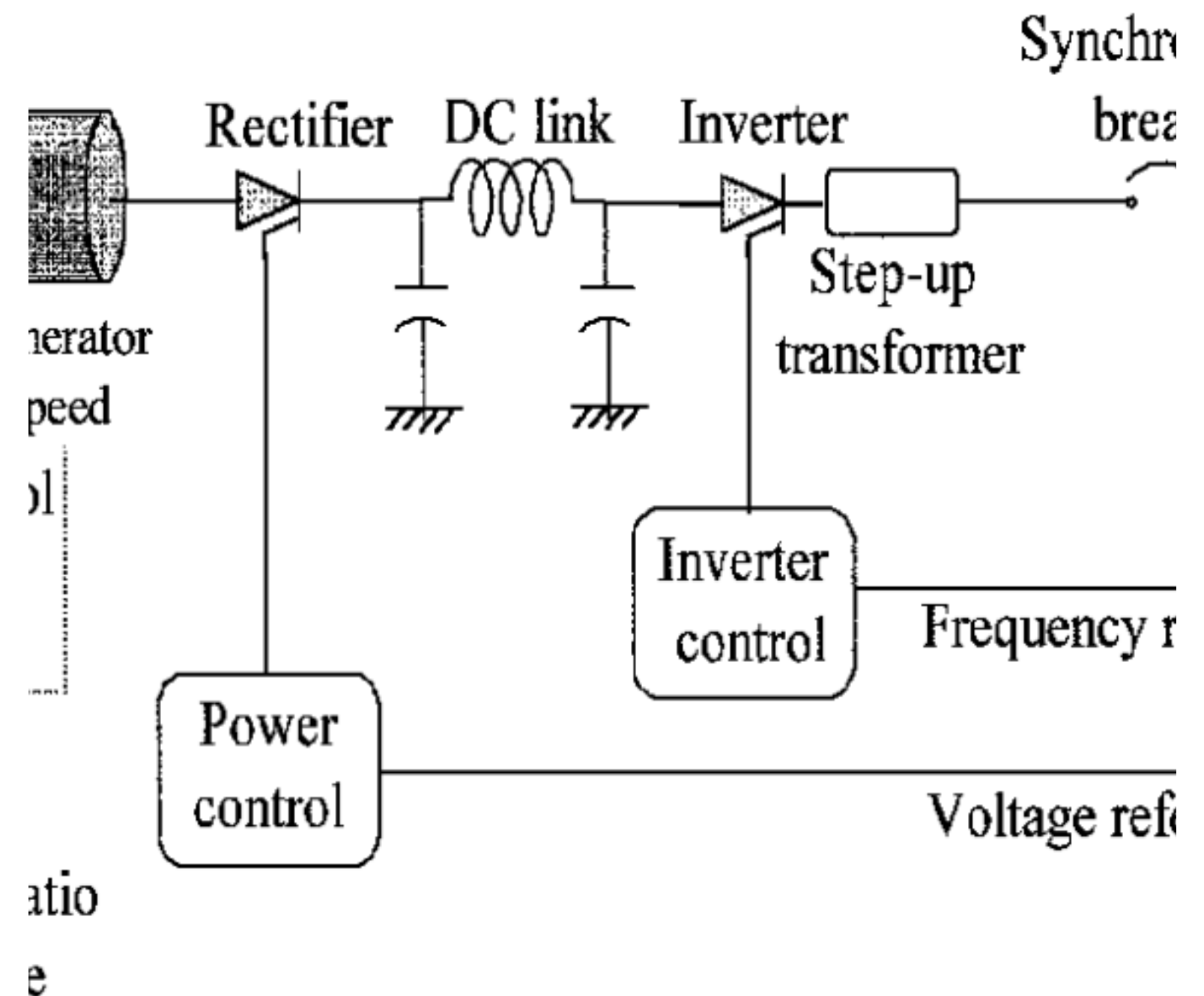

Figure - 11: Electrical system layout of a Typical Grid-connected wind power system.

- Large wind systems being installed now tend to have a variable-speed design
- The power schematic of such a system is shown in the figure below (Figure 12). The variable-frequency generator output is first rectified into DC, and then inverted into a fixed-frequency AC. Before the inversion, the rectifier harmonics are filtered out from the DC by inductors and capacitors.
- The frequency reference for the inverter firing and the voltage reference for the rectifier phase-angle control are taken from the grid lines.
- The optimum reference value of the tip-speed ratio is stored and continuously compared with the value computed from the measured speeds of the wind and the rotor. The turbine speed is accordingly changed to assure maximum power production at all times



- 3.2 Interface Requirements: Both the wind and the PV systems interface the grid at the output terminals of the synchronizing breaker at the output end of the inverter.
- The power flows in either direction depending on the site voltage at the breaker terminals.
- The fundamental requirements on the site voltage for interfacing with the grid are as follows:
 - The voltage magnitude and phase must equal to that required for the desired magnitude and direction of the power flow. The voltage is controlled by the transformer turn ratio and/or the rectifier/ inverter firing angle in a closed loop control system.
 - The frequency must be exactly equal to that of the grid, or else the system will not work. To meet the exacting frequency requirement, the only effective means is to use the utility frequency as a reference for the inverter switching frequency
 - In the wind system, the synchronous generators of the grid system supply magnetizing current for the Induction Generator.

Synchronizing with Grid:

- Four conditions which must be satisfied before the synchronizing switch will permit the closure are as follows:
 - The frequency must be as close as possible with the grid frequency.
 - The terminal voltage magnitude must match with that of the grid, preferably a few percent higher.
 - The phase sequence of both the three-phase voltages must be same.
 - The phase angle between the two voltages must be within 5 degrees

Linking wind turbines to the grid

It involves several key stages:

1. Collecting Power From Individual Turbines Via An Underground Medium-voltage (MV) Network,
2. Transporting It To A Collector Substation,
3. Transforming It To A High Voltage For Efficient Transmission,
4. Finally Connecting It To The Broader National High-voltage (HV) Grid.

offshore wind farms:

this process extends to an offshore substation and subsea cables, often employing High-Voltage Direct Current (HVDC) for longer distances to minimize transmission losses.



Layout of wind power plant

- The power collection system connects all turbines to the Point of Connection (PoC) to the grid
- Auxiliary equipment like SVCs or reactors are often applied

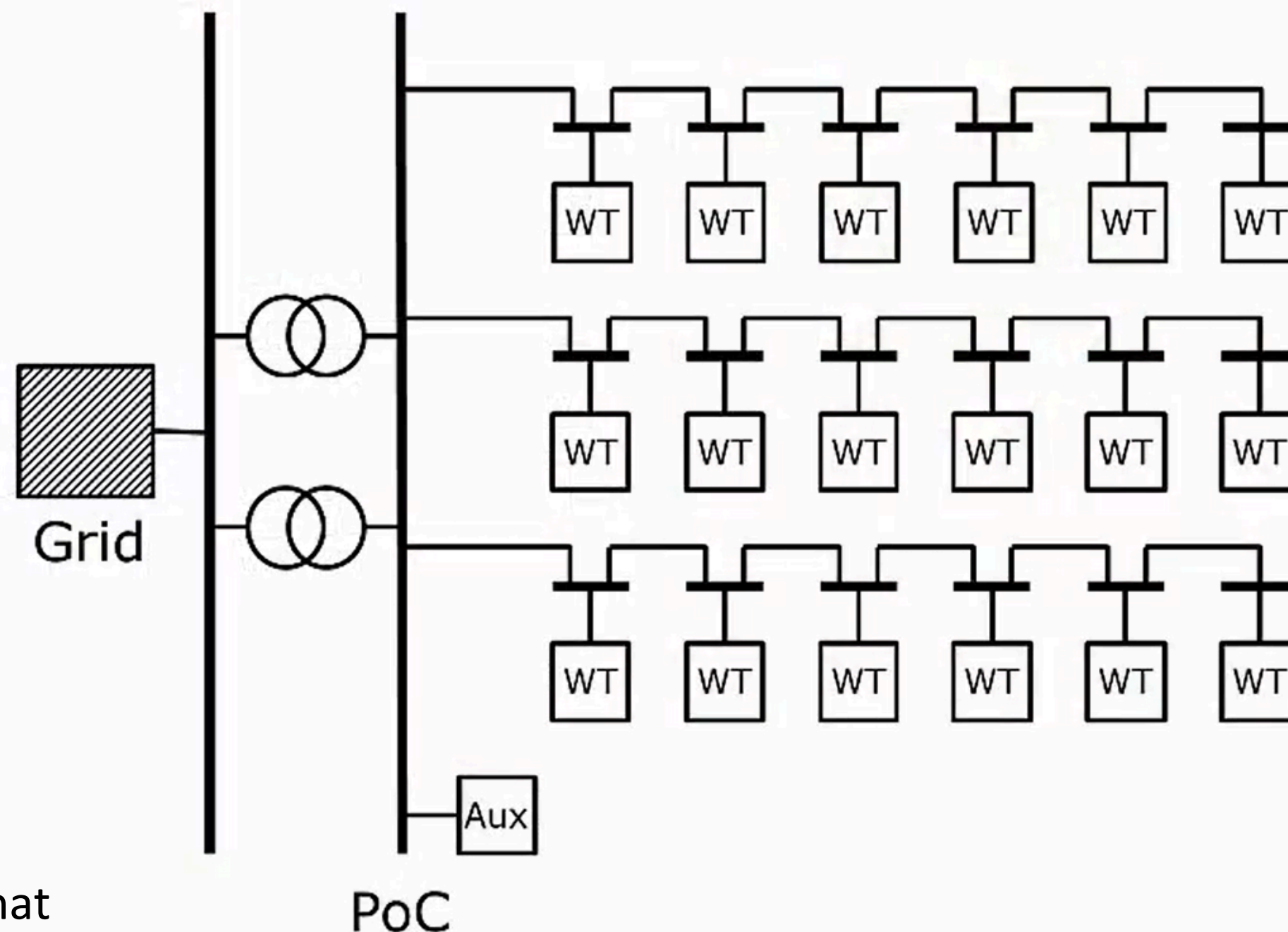

SVC stands for Static Var Compensator, a type of FACTS (Flexible AC Transmission System) device that uses power electronics to provide fast, dynamic reactive power control to stabilize voltage, improve power quality, and enhance grid stability.

Key Components and Steps

- **Turbine Interconnection:**

Individual wind turbines are linked together using a medium-voltage (MV) electrical network, usually a network of underground cables.

- **Collector Substation:**

The power from multiple turbines is channeled to a collector substation. This substation serves as a hub, where the energy is aggregated and protected.

- **Voltage Transformation:**

At the substation, the voltage is increased by a power transformer to match the voltage of the national high-voltage (HV) grid, reducing energy losses during transmission.

- **Grid Connection:**

The higher-voltage electricity then moves onto the national transmission network, ready to be used by homes and businesses.

Connection to different voltage levels

- Small wind turbines may be connected to Low Voltage (e.g. 0.4 kV) distribution grid
- Groups of onshore wind turbines are usually connected to Medium Voltage (e.g. 50/10 kV) substations
- Large (e.g. offshore) wind farms are connected to High Voltage (e.g. 150kV) transmission system

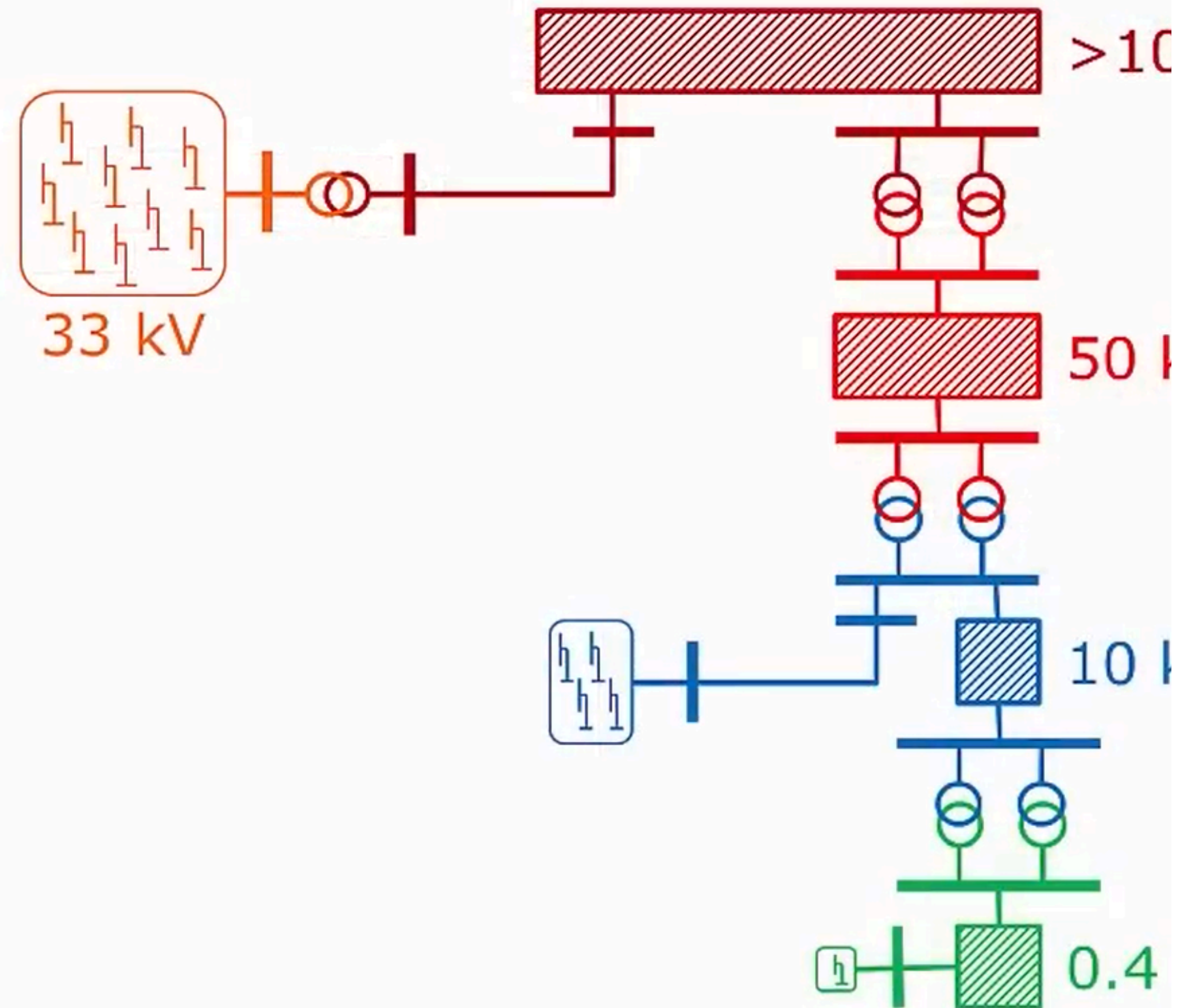

- Special Considerations for Offshore Wind
- **Offshore Substation:**
For offshore wind farms, power is first sent to a central offshore substation.
- **Subsea Export Cables:**
From the offshore substation, subsea cables transmit the power to the onshore grid connection system.
- **HVDC Technology:**
Over long underwater distances, the electricity is often converted to High-Voltage Direct Current (HVDC) for greater efficiency.

Offshore AC and DC connections



- Power cannot be transmitted stably in long distance cables using alternating current (AC) without compensation equipment (reactors)
- Therefore, direct current is chosen for long distance offshore transmission
- Offshore DC connections often serve several wind power plants with different owners

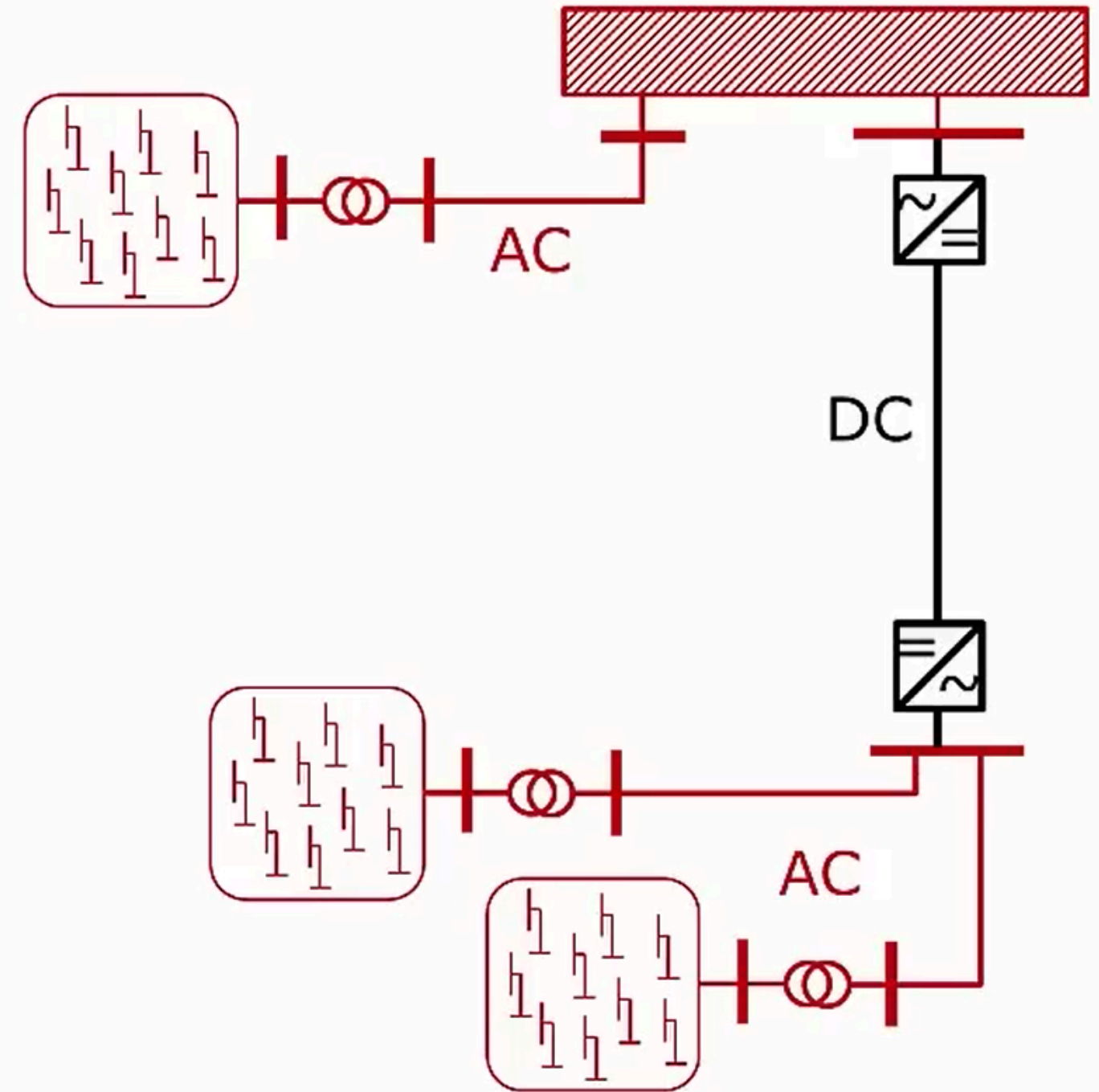

Technical Requirements

- **Grid Infrastructure:**

A physical and technical infrastructure, referred to as a grid connection, is required to link offshore wind farms to the onshore grid.

- **Coordination:**

Close coordination is necessary between the wind farm design and its grid connection to ensure synchronization and minimize financial risks, especially for complex offshore projects.

- **Reactive Power Compensation:**

In larger wind farms, systems are used to minimize reactive power flow, ensuring a more stable connection to the grid.

Power Converter Topologies for Wind Turbine Generators.

- The two main power converter topologies for modern wind turbines are
- **Partial-conversion** (or back-to-back converter), often used with Doubly-Fed Induction Generators (DFIG), and
- **Full-conversion** (or back-to-back converter), which uses a Permanent Magnet Synchronous Generator (PMSG) connected to the grid via an AC-DC-AC converter.
- Partial converters are less complex and offer some cost advantages, while full converters provide superior control, energy extraction, and better power quality for variable-speed operation.
- Other, less common topologies include matrix converters and various multilevel converters.

**~40% of total turbine power
passes through the converter**

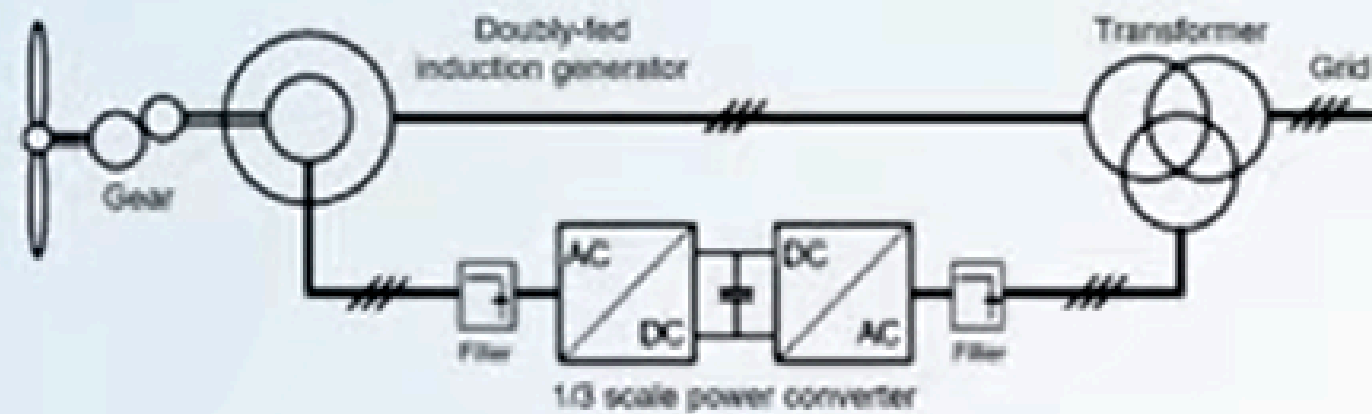

**Less maintenance and
better grid support**

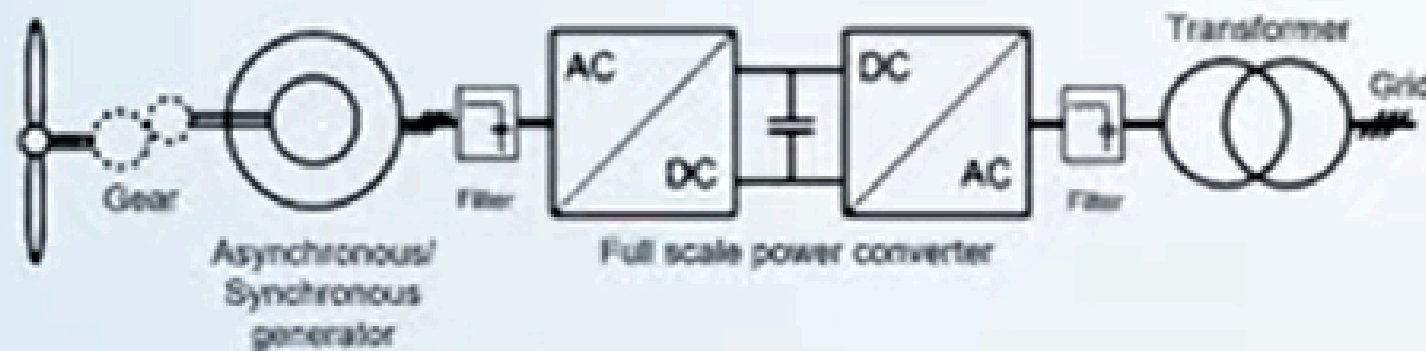

Partial converter

(DFIG)

Stator of generator directly connected to grid

Rotor connected to grid through
back-to-back power converter

Lower capital cost

Power rating: 1.5 MW – 6 MW

Full converter

(used for IG and PMSG)

Generator fully decoupled from the grid
through back-to-back power converter

Power rating: 0.8 MW – 10 MW

1. Partial-Conversion Systems (DFIG)

- **Generator:**
- Typically uses a Doubly-Fed Induction Generator (DFIG) with wound rotor and a slip ring.
- **Converter:**
- A back-to-back converter topology connects the rotor to the grid, allowing control over the variable-speed operation. The stator is directly connected to the grid.
- **Function:**
- The converter controls the power flow between the rotor and the grid, enabling variable-speed operation for better energy capture and reduced mechanical stress.
- **Advantages:**
- This is a flexible and optimized, often more cost-effective, topology.

2. Full-Conversion Systems (PMSG)

- **Generator:**
- Commonly employs a Permanent Magnet Synchronous Generator (PMSG).
- **Converter:**
- A full AC-DC-AC power electronic converter, often a two-level or multilevel voltage source converter (VSC), is used.
- **Function:**
- The converter fully handles the AC-DC-AC conversion, allowing for independent control of active and reactive power, which optimizes energy extraction and improves grid integration.
- **Advantages:**
- Offers superior control over the generator and grid, leading to increased power capture and better power quality.
-

Use of **full power wind converters** is increasing due to the installation of **more and more offshore wind turbines**

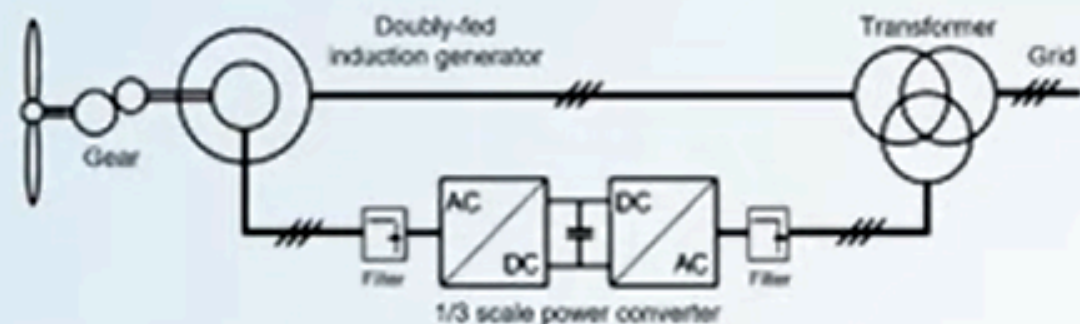

Partial converter (DFIG)

- + Onshore
- + Lower overall cost
- + Can meet existing grid codes
- Maintenance more expensive
- Limited to 6 MW

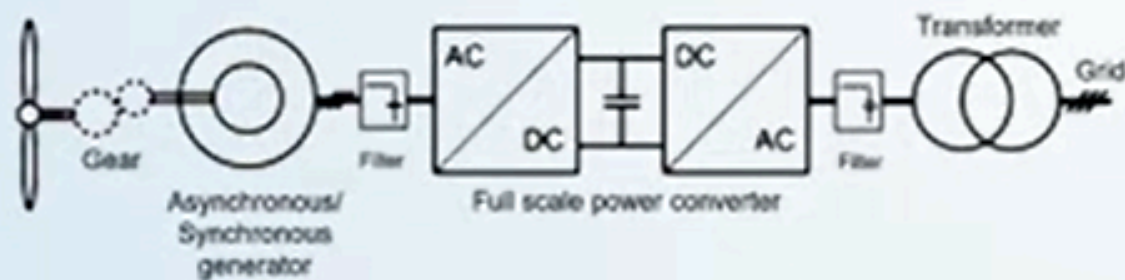





Full converter

- + Onshore and offshore
- + Optimized system performance
- + Scalable to meet higher power level
- Nacelle's weight increases as turbine's power level increases
- More expensive

Onshore turbines with full converters are also increasing compared to **DFIG**-based wind turbines

Requirements

-  **High power density**
-  **High reliability and robustness**
-  **Long lifetime**
-  **Excellent system efficiency**

<https://www.youtube.com/watch?v=LQS9Jr2R5cM>