

UNIT-III

Power Flow Analysis in AC/DC Systems

Introduction:

Power flow analysis is an essential component of system studies carried out for planning, design and operation of power systems. The power flow or load flow analysis of AC systems has been thoroughly investigated in terms of numerical algorithms for obtaining the solution to the nonlinear algebraic equations. This chapter presents the power flow in the AC and DC system.

Modelling of DC Links

DC Network:

- The DC network consisting of DC links, smoothing reactor and converters can be viewed as a resistive network excited by current or voltage sources in steady state.
- Depending on the series connection of converters, it may be appropriate to consider loop resistance or nodal conductance matrix.
- The elements of the DC network can be separated into tree branches and links.
- Radial DC networks, there is no loss of generality in assuming that all the resistances form a subset of tree branches.
- The converters can be divided into either tree branches or links.

The equations describing the DC network are

$$-[g] v_g = i_g$$

$$i_g = -B_{Lg} I_{dL}$$

$$i_{dT} = -B_{LT} I_{dL}$$

$$\begin{aligned} V_{dL} &= B_{Lg}^t V_g + B_{LT}^t V_{dT} \\ &= B_{Lg}^t [g]^{-1} B_{Lg} I_{dL} + B_{LT}^t V_{dT} \end{aligned}$$

- It is assumed that N converters can be put into m groups, the AC converter bus is identical.
- The number of converters in i^{th} group is n_i
- The voltage equation for the converter 'j' in group 'σ' is

$$V_{dj} = \left(\frac{3\sqrt{2}}{\pi}\right) \left(\frac{N_{sj}}{N_{pj}}\right) \left(\frac{E_{\sigma}}{T_j}\right) V_{b\sigma} \cos \alpha_j - \left(\frac{3}{\pi}\right) X_{cj} I_{dj}$$

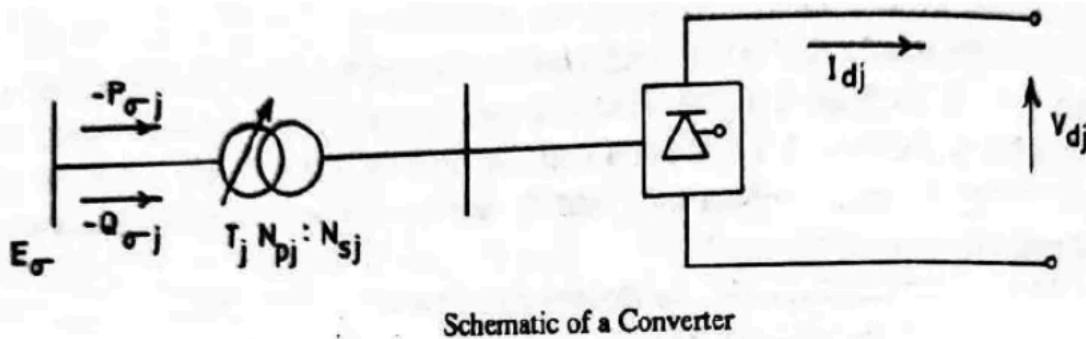

X_{cj} is the leakage reactances of the transformer referred to secondary in ohms

N_{pj} and N_{sj} are the nominal turns of primary and secondary winding

T_j is the off nominal turns ratio of the transformer

Controller Equations:

Control equation of converter is

$$F_{dj} = C_j F_{d\sigma}$$

F_{dj} - stands for DC voltage (or current) in series (or parallel) connected converters in a station

If the N converter DC system is connected to the AC system at m stations(buses),it is obvious that the power can be specified only at (m-1) stations at the most.

At each converter the angle (α or γ) and the transformer tap (T) can be controlled directly within limits to achieve

- (i) current control
- (ii) DC voltage control
- (iii) Power control
- (iv) Control of reactive power

Solution of AC-DC Power flow

The solution methodology for AC-DC power flow can be classified as

1. Simultaneous or unified
2. Sequential or alternating

1. Simultaneous or unified:

- In the Simultaneous method the AC and DC equations are solved together.
- The simplest implementation of this approach is to consider all the equations for DC and AC systems combined into one set of nonlinear algebraic equations.
- A Jacobian matrix is then constructed and Newton's method is used to solve this set of equations.
- A variation of this approach is to use the 'Fast Decoupled' method of solution for the AC system equations.

2. Sequential or alternating:

- In the Sequential or alternating method the AC and DC system equations are solved separately and sequentially.
- The AC system is solved to some degree of convergence using a simple model for the DC system based on its solution.
- The DC system is then solved using a simplified representation of the AC system.
- Represent the AC system as a constant voltage, constant angle model at every converter and the DC system as a constant active and reactive power source during the AC solution.

- Represent the AC system by an uncoupled or coupled Thevenin's equivalent model during the DC solution.

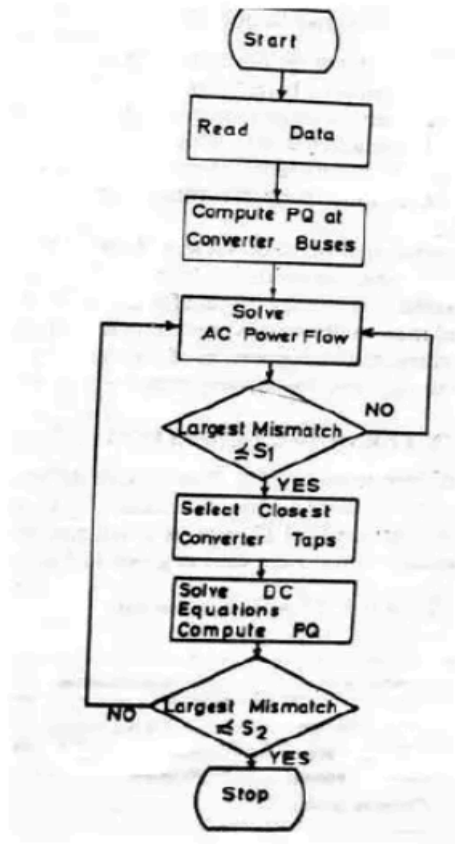

Flow chart of AC/DC Load Flow



NARSIMHA REDDY ENGINEERING COLLEGE

An Autonomous Institution | Affiliated to JNTUH | Approved by AICTE
Accredited by NBA & NAAC with 'A' Grade